



ENGINEERING MANUAL

MODULAR PLASTIC CONVEYOR BELTS

TABLE OF CONTENTS

SECTION ONE: INTRALOX OVERVIEW	3
BELT CONSTRUCTION	4
DRIVE METHOD	4
DESIGN REQUIREMENTS	5
BELT SELECTION PROCESS	5
INTRALOX SERVICES	7
SECTION TWO: PRODUCT LINE	9
STANDARD BELT MATERIALS	9
SPECIAL APPLICATION BELT MATERIALS	9
BELT MATERIAL PROPERTIES	12
FRICTION FACTORS	13
BELT MATERIAL COMPLIANCE	14
GENERAL APPLICATION SPROCKET MATERIAL	15
SPECIAL APPLICATION SPROCKET MATERIAL	15
SPROCKET MATERIAL AVAILABILITY	16
BELT SELECTION INSTRUCTIONS	20
STRAIGHT RUNNING BELTS	
SERIES 100	23
SERIES 200	29
SERIES 400	37
SERIES 550	63
SERIES 800	67
SERIES 850	97
SERIES 888	105
SERIES 900	113
SERIES 1000	141
SERIES 1100	157
SERIES 1200	175
SERIES 1400	189
SERIES 1500	213
SERIES 1600	219
SERIES 1650	231
SERIES 1700	235
SERIES 1750	243
SERIES 1800	247
SERIES 1900	253
SERIES 4400	259
SERIES 4500	263
SERIES 9000	273
SERIES 10000	279
RADIUS BELTS	
SERIES 2100	289
SERIES 2200	293
SERIES 2300	305
SERIES 2400	311
SERIES 3000	339
SERIES 4000	345
SPIRAL BELTS	
SERIES 2600	361
SERIES 2700	373
SERIES 2800	383
SERIES 2850	393
SERIES 2900	397
SERIES 2950	405
SQUARE SHAFTS	409
RETAINER RINGS/CENTER SPROCKET OFFSET	410
ROUND BORE ADAPTERS	412
SCROLL IDLERS	413
WEARSTRIPS	414
CUSTOM WEARSTRIPS	416
PUSHER BARS	417
DEAD PLATES	417
EZ CLEAN IN PLACE SYSTEM (CIP)	418
HOLD DOWN ROLLERS	418
ABRASION RESISTANCE SYSTEM	419
ABRASION RESISTANCE HINGE RODS	420
EZ MOUNT FLEX TIP SCRAPER	421
SECTION THREE: DESIGN GUIDELINES	423
BASIC CONVEYOR FRAME REQUIREMENTS	423
DIMENSION DEFINITIONS	424
DRIVE GUIDELINES	425
SHAFT SIZES AND MATERIALS	425
DRIVE SHAFT TORQUE LOADING	425
POWER REQUIREMENTS	425
RETAINING SPROCKETS	426
INTERMEDIATE BEARINGS	426
ROLLERS AS IDLE SHAFTS AND SPROCKET REPLACEMENTS	426
SOFT STARTING MOTORS AND FLUID COUPLINGS	426
BELT CARRYWAYS	427
SOLID PLATE CARRYWAYS	427
WEARSTRIP CARRYWAYS	427
ANTI-SAG CARRYWAY WEARSTRIP CONFIGURATION	428
WEARSTRIP DESIGN CONSIDERATIONS	428
RETURNWAYS AND TAKE-UPS	428
CONTROL OF BELT LENGTH	428
BACK TENSION	429
STANDARD RETURNWAYS	429
SPECIAL TAKE-UP ARRANGEMENTS	431
SPECIAL CONVEYORS	432
BI-DIRECTIONAL CONVEYORS	432
ELEVATING CONVEYORS	434
RADIUS CONVEYORS	438
TIGHT TRANSFER METHODS	439
TRANSFER DESIGN GUIDELINES	440
END-OFF/END-ON TRANSFERS	440
SPECIAL DESIGN GUIDELINES	443
THERMAL EXPANSION AND CONTRACTION	443
EXPANSION DUE TO WATER ABSORPTION	443
"SLIP-STICK" EFFECT	443
SECTION FOUR: FORMULAS AND TABLES	445
SYMBOLS USED	445
FORMULAS	446
SAMPLE PROBLEMS	450
TABLES	454
MEASUREMENT CONVERSION FACTORS	460
CHEMICAL RESISTANCE GUIDE	461
STRAIGHT RUNNING BELT DATA SHEET	467
RADIUS BELT DATA SHEET	469
GLOSSARY	471
INDEX	475



Conveyor Belting Engineering Manual

WARRANTY

Intralox, LLC warrants products of its own manufacture for a period of one year from date of shipment to the extent that Intralox, LLC will repair or replace any products of faulty material or defective workmanship proven under normal use or service. No other warranty is expressed or implied unless otherwise set forth in writing and approved by a representative duly authorized to extend such approval by Intralox, LLC.

CAUTION

Intralox, LLC does not warrant that the design and/or operational function of any machine that incorporates and/or intends to incorporate Intralox, LLC products, conform to any local, state and/or federal regulations and standards relating to public safety, worker safety, safety guards, sanitation safety, fire safety, or any other safety regulations. ALL PURCHASERS AND USERS SHOULD CONSULT THEIR APPROPRIATE LOCAL, STATE AND FEDERAL SAFETY REGULATIONS AND STANDARDS.

NOTICE

The information contained in this manual is provided only as an aid and service to our customers. Intralox, LLC does not warrant the accuracy or applicability of such information and, Intralox, LLC is specifically not responsible for property damage and/or personal injury, direct or indirect for damages and/or failures caused by improper machine design, application, installation, operation, abuse and/or misuse of its products whether or not based on information contained herein.

WARNING

Intralox products are made of plastic and can burn. If exposed to an open flame or to temperatures above Intralox specifications, these products may decompose and emit toxic fumes. Do not expose Intralox conveyor belting to extreme temperatures or open flame. Flame retardant belt products are available in some series. Contact Intralox.

MAINTENANCE

Prior to installing, aligning, cleaning, lubricating or performing maintenance on any conveyor belt, sprocket or system, consult the federal, state and local regulations in your area regarding the control of hazardous/stored energy (lockout/ tagout).

Intralox, LLC warrants products of its own manufacture for a period of one year from date of shipment to the extent that Intralox, LLC will repair or replace any products of faulty material or defective workmanship proven under normal use or service. No other warranty is expressed or implied unless otherwise set forth in writing and approved by a representative duly authorized to extend such approval by Intralox, LLC.

Intralox, L.L.C. manufactures products under one or more of the following U.S. patents: 5,072,640 - 5,074,406 - 5,083,660 - 5,101,966 - 5,156,262 - 5,156,264 - 5,316,522 - 5,361,893 - 5,372,248 - 5,377,819 - 5,507,383 - 5,544,740 - 5,597,063 - 5,598,916 - 5,850,902 - 5,904,241 - 6,119,848 - 6,138,819 - 6,148,990 - 6,209,714 - 6,209,716 - 6,334,528 - 6,367,616 - 6,398,015 - 6,401,904 - 6,439,378 - 6,467,610 - 6,474,464 - 6,494,312 - 6,499,587 - 6,554,129 - 6,571,937 - 6,644,466 - 6,681,922 - 6,695,135 - 6,705,460 - 6,749,059 - 6,758,323 - 6,811,021 - 6,837,367 - 6,926,134 - 6,968,941 - 6,997,306 - 7,055,678 - 7,070,043 - 7,111,725 - 7,147,099 - 7,191,894 - 7,210,573 - 7,216,759 - 7,228,954 - 7,237,670 - 7,249,669 - 7,249,671 - 7,248,653 - 7,311,192 - 7,344,018 - 7,360,641 - 7,393,451 - 7,424,948 - 7,426,992 - 7,461,739 - 7,494,006 - 7,506,750 - 7,506,751 - 7,533,776 - 7,537,104 - 7,537,106 - 7,540,368 - 7,575,113 - 7,588,137 - 7,607,533 - 7,617,923. Other U.S. and foreign patents pending.

A subsidiary of the Laitram, LLC. All rights reserved worldwide. Intralox is a registered trademark of the Laitram, LLC. © 2019 Intralox, LLC. 5006038 English.

**FOR CUSTOMER SERVICE AND
APPLICATION ENGINEERING
ASSISTANCE, CALL THE NUMBERS
LISTED ON THE BACK COVER OF
THIS MANUAL.**

INDEX OF FIGURES AND TABLES

Fig. 1-1	Bricklaid modules	4
Fig. 2-1	HOLD DOWN RAILS AND WEARSTRIPS FOR SERIES 2200 FLAT-TURNS	303
Fig. 2-2	TYPICAL 2-TURN RADIUS LAYOUT	304
Fig. 2-3	SERIES 2400 HOLD DOWN GUIDES FOR FLAT TURNS	332
Fig. 2-4	HOLD DOWN RAILS AND WEARSTRIPS FOR SERIES 2400 FLAT-TURNS - STANDARD BELTS	335
Fig. 2-5	HOLD DOWN RAILS AND WEARSTRIPS FOR SERIES 2400 FLAT-TURNS - HIGH DECK AND RAISED RIB BELTS	335
Fig. 2-6	HOLD DOWN RAILS AND WEARSTRIPS FOR SERIES 2400 FLAT-TURNS - BELTS WITH HOLD DOWN GUIDES	336
Fig. 2-7	TYPICAL 2-TURN RADIUS LAYOUT	337
Fig. 2-8	HOLD DOWN RAILS AND WEARSTRIPS FOR SERIES 2600 FLAT-TURNS	371
Fig. 2-9	TYPICAL 2-TURN RADIUS LAYOUT	372
Fig. 2-10	HOLD DOWN RAILS AND WEARSTRIPS FOR SERIES 2700 FLAT-TURNS	381
Fig. 2-11	TYPICAL 2-TURN RADIUS LAYOUT	382
Fig. 2-12	HOLD DOWN RAILS AND WEARSTRIPS FOR SERIES 2800 FLAT-TURNS	390
Fig. 2-13	TYPICAL 2-TURN RADIUS LAYOUT	391
Fig. 2-14	HOLD DOWN RAILS AND WEARSTRIPS FOR SERIES 2900 FLAT-TURNS	402
Fig. 2-15	TYPICAL 2-TURN RADIUS LAYOUT	403
Fig. 2-16	Shaft dimensions	409
Fig. 2-17	Retainer rings	410
Fig. 2-18	Round bore adapter	412
Fig. 2-19	Flat finger-joint wearstrips	414
Fig. 2-20	UHMW Specialty wearstrips	414
Fig. 2-21	Stainless steel backed UHMW wearstrips	415
Fig. 2-22	120" UHMW RADIUS BELT CUSTOM WEARSTRIPS	416
Fig. 2-23	Pusher bar side view	417
Fig. 2-24	Pusher bar assembly	417
Fig. 2-25	Dual blade pusher bar assembly	417
Fig. 2-26	Dead plates	417
Fig. 2-27	Split sprockets	419
Fig. 2-28	Abrasion resistant (all steel) sprockets	419
Fig. 2-29	Abrasion resistant rods and rodlets	420
Fig. 2-30	Series 1100 side view	420
Fig. 2-31	Series 1400 with Slidelox®	420
Fig. 3-1	Conventional conveyor components	423
Fig. 3-2	Basic dimensional requirements (roller returnway)	423
Fig. 3-3	Chordal effects - bottom of range	424
Fig. 3-4	Chordal effects - top of range	424
Fig. 3-5	Typical shaft features	425
Fig. 3-6	Intermediate bearings recommended mounting arrangement	426
Fig. 3-7	Straight, parallel wearstrip arrangement	427
Fig. 3-8	Chevron wearstrip arrangement	427
Fig. 3-9	Buckling belt rows	428
Fig. 3-10	Anti-sag configuration	428
Fig. 3-11	Short conveyors (less than 6' [1.8 m])	430
Fig. 3-12	Medium to long conveyors (6' [1.8 m] and longer)	430
Fig. 3-13	Conveyors with slide beds	430
Fig. 3-14	Gravity style take-up	431
Fig. 3-15	Center-driven bi-directional conveyor	433
Fig. 3-16	Center drive with nose bars	433
Fig. 3-17	Push-pull bi-directional conveyor	434
Fig. 3-18	Incline conveyor	435
Fig. 3-19	Decline conveyor	435
Fig. 3-20	Elevating conveyor with belt edge slider return	436
Fig. 3-21	Elevating conveyor with wide sideguards and shoe return	436
Fig. 3-22	Elevating conveyor with shoe return	437
Fig. 3-23	Hold down roller	437
Fig. 3-24	Hold down roller, side view	438
Fig. 3-25	Hold down roller, side view	438
Fig. 3-26	Series 1100 nosebar configuration — End drive	439
Fig. 3-27	Finger transfer plates dimensional requirements	440
Fig. 3-28	Dead plate gap	441
Fig. 3-29	Conventional full radius guide rail contours	441
Fig. 3-30	Parabolic guide rail contours	442
Fig. 3-31	PARABOLIC GUIDE RAIL CONTOURS WITH 6.0 in. (152 mm) ONEPIECE™ LIVE TRANSFER BELT	442
Fig. 4-1	Primary loads — conventional conveyor	446
Fig. 4-2	Catenary sag	449
Table 1	(W) BELT WEIGHT IN lb/ft ² (kg/m ²)	454
Table 2	(F _w) COEFFICIENT OF START-UP FRICTION BETWEEN WEARSTRIP & BELT	454
Table 3	(F _r) COEFFICIENT OF RUNNING FRICTION BETWEEN CONTAINER & BELT	454
Table 4	BELT STRENGTHS IN lb/ft (kg/m)	454
Table 5	SPROCKET AND SUPPORT QUANTITY REFERENCE	455
Table 6	(SF) SERVICE FACTOR	455
Table 7	(T) TEMPERATURE FACTOR	456
Table 8	SHAFT DATA	457
Table 9	MAXIMUM RECOMMENDED TORQUE ON DRIVE SHAFT	457
Table 10	BELT PULL LIMITS VS SHAFT SPAN FOR RETAINER RING GROOVES	457
Table 11	AIR FLOW RATE THROUGH BELT, PER SQUARE FOOT OF BELT AREA	458
Table 12	MAXIMUM DRIVE SHAFT SPAN LENGTH (CONVENTIONAL CONVEYORS)	459

SECTION ONE: INTRALOX OVERVIEW

With more than 40 years' experience, Intralox continues to lead the way in helping customers achieve their goals by offering comprehensive conveyance solutions that create significant economic value. Intralox delivers innovative, premium technology within a direct business model and a global, industry-specific structure. Our industry-specific teams have an in-depth knowledge of customer applications and provide technical support and consulting, and 24/7 customer service. Working with Intralox allows you to experience our uncompromising commitment to providing solutions and solving problems for our customers.

We pushed past the boundaries of traditional conveying systems with the revolutionary invention of modular plastic belting, and continue to move beyond industry standards with new products, equipment, solutions, and services. Intralox's commitment to innovation has led to over 800 patents currently in force around the world. If our customers have a need, we invent smart solutions to solve them.



BELT CONSTRUCTION



All Intralox belts are constructed with injection-molded plastic modules. These are assembled into interlocked units and joined by plastic hinge rods. Except for narrow belts (one complete module or less in width), all are built with the joints between modules staggered with those of adjacent rows in a “bricklaid” fashion. This structure interlocks the modules, giving the belt inherent lateral strength. The hinge rods do not hold the belt together from side to side, but act only as pivot members in shear. The belt that results from this construction process is intrinsically strong, both laterally due to the bricklaying, and longitudinally due to the rods being placed in multiple shear.

Because of modular construction, Intralox belts can be made in almost any width from three links wide.

Each belt style incorporates several distinguishing features. Hinge and edge features are described below. Surface, pitch and drive features are described in detail in “*Belt Selection Process*” (page 5).

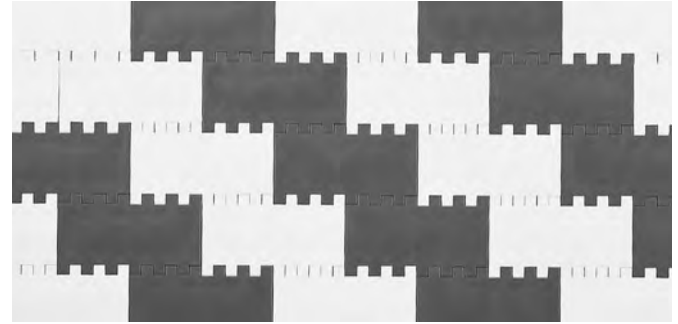

Fig. 1-1 Bricklaid modules

OPEN HINGES — The hinge rods are visible from either the top or bottom surface (or both) of the belt to aid in belt inspection.

CLOSED HINGES — The hinge rods are completely enclosed to protect them from abrasives or contaminants.

FLUSH EDGES — Flush edges ride snugly beside the conveyor frame rails without gaps or exposed rod heads. They reduce the possibility of product, or belt, snagging on the frame.

DRIVE METHOD

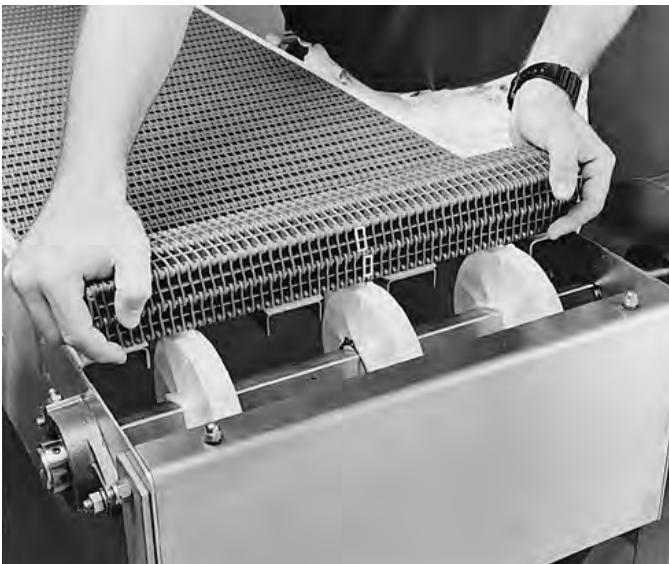

Intralox belts are positively driven by plastic or metal sprockets, not friction rollers. The sprockets, another part of the Intralox System, have square bores and are driven by matching square shafts. (Note: Sprockets are available with round bores for special applications.) Not only do square

shafts transmit torque (rotational force) without the need for troublesome keys and keyways, they accommodate the lateral expansion differences of the plastic belt material and the metal shafts. Only one sprocket per shaft is retained. The others are allowed to “float”, moving along the shaft as the belt expands or contracts. Thus, the sprockets are always transmitting torque. Of all belt drive systems tested, the square shaft with square bore sprockets has proven to be the most effective, economical, reliable, trouble free and simple.

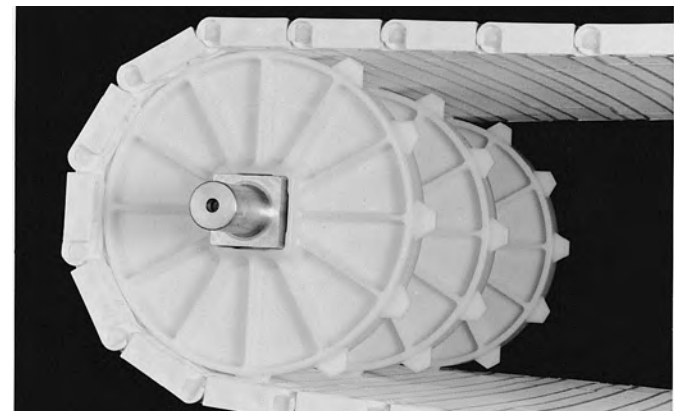

DESIGN REQUIREMENTS

Intralox conveyor belts are available in a variety of styles, materials and colors, with many accessory options. In order to make the appropriate selections when designing for a particular application, reliable information about operating and environmental conditions is critical.

Factors to evaluate include:

- The type of belt system: straight running, radius, or spiral
- The overall dimensions of the installed belt: length between driving and idling shafts, width, elevation changes
- The speed of belt travel
- The characteristics of the product to be conveyed:
 1. density
 2. unit size and shape
 3. hardness, toughness, brittleness, rigidity
 4. texture (smooth, rough, granular, lumpy, spongy. . .)
 5. corrosiveness
 6. moisture content
 7. temperature
 8. frictional nature
- Any process change in the product during conveyance:
 1. heating

2. cooling
3. washing, rinsing, draining
4. drying

- The sanitary and cleanliness requirements and conditions:
 1. USDA-FSIS approval
 2. harsh temperatures or chemicals
 3. continuous on-line cleaning
- The planned methods of product loading and removal — smooth or impact transfers
- The characteristics of the operating environment:
 1. temperature
 2. moisture, humidity
 3. chemical nature (acid, base, etc.)
 4. abrasive materials (sand, grit, etc.)
 5. hazardous materials (dusts, vapors, etc.)
- The type of drive system:
 1. motors
 2. chains.

For more detailed information, see “*Section three: Design guidelines*” (page 423).

BELT SELECTION PROCESS

STEP ONE: Choose the right type of belt system.

Choose a Straight running, Radius, or Spiral belt system.

STEP TWO: Choose the right material for your application.

Intralox belts and accessories are available in standard and special application materials. For complete descriptions of the standard and special application belt materials see, “*Standard Belt Materials*” (page 9) and “*Special Application Belt Materials*” (page 9).

Contact the Intralox Sales Engineering Department or Customer Service for more information. Current telephone numbers are listed on the back cover.

For specific recommendations on chemical properties, see “*Chemical Resistance Guide*” (page 461).

STEP THREE: Select the best belt surface, pitch and drive method.

Next in the process of choosing the belt for your application is to determine the belt surface or style best suited for the product or material being conveyed.

The pitch of the belt is the next differentiating feature. Intralox belts are available in 0.315 in. (8.0 mm), 0.50 in. (12.7 mm), 0.60 in. (15.2 mm), 1.00 in. (25.4 mm), 1.07 in. (27.2 mm), 1.44 in. (36.6 mm), 1.50 in. (38.1 mm), 2.00 in. (50.8 mm), 2.07 in. (52.6 mm) and 2.50 in. (63.5 mm) 3.00 in. (76.2 mm) pitches. Smaller pitch reduces chordal action (over similar size sprockets) and the space required for product transfer.

Drive method should also be considered. There are two drive methods used by Intralox: hinge-driven and center-driven. Where back tension is an important consideration, drive method plays a significant role.

Note: Unless otherwise noted, the belts have fully flush edges.

STEP FOUR: Select a belt of sufficient strength for your application.

After choosing the material and surface style to meet your needs, next determine if the belt selected is strong enough to meet your application requirements.

ANALYSIS FOR STRAIGHT RUNNING BELTS:

After making a tentative selection from the Series and Styles listed above, turn to the “Belt Selection Instructions” (page 20), Product Line, for instructions to determine the Belt Pull and Adjusted Belt Pull for comparison with the Allowable Strength for that belt. In order to make the necessary calculations for Belt Pull, gather this information:

1. the product weight applied to the belt, in pounds per square foot (or kilograms per square meter),
2. the length of the proposed conveyor, in feet (or meters),
3. any elevation changes in the conveyor, in feet (or meters),
4. the desired operating speed, in feet per minute (or meters per minute),
5. the percent of belt area “backed-up” with stationary product,
6. the maximum operating temperature to be experienced by the belt, in degrees Fahrenheit (or degrees Celsius),
7. the type of material upon which the belt will run in the conveyor frame, e.g., Stainless or Carbon Steel, Ultra High Molecular Weight Polyethylene (UHMW), High Density Polyethylene (HDPE), nylon, etc., and
8. the Service Duty, i.e., frequent start-ups under heavy load, an elevating or “pushing conveyor”, etc.

ANALYSIS FOR RADIUS AND SPIRAL BELTS:

These belts require a more complex analysis. The following additional information is required:

9. the length of each straight run,
10. the turning angle and direction of each turn, and
11. the inside turning radius, measured from the inside edge of the belt.

STEP FIVE: Other important considerations.

The following factors should be considered before proceeding any further with belt selection.

ROD MATERIAL

Each Belt style and material is presented with a standard rod material; however, other rod materials are available and should be evaluated based on your application. Contact Customer Service for more information.

BELT SPEED

The belt speed affects the wear and life expectancy in these ways:

1. Hinge and sprocket wear: The frequency of module rotation about the hinge rods (as the belt engages and disengages the sprockets) is directly proportional to speed. The rotary motion can cause wear to both rods and modules. This wear rate, however, is inversely proportional

to the belt’s length, i.e., a shorter conveyor should wear faster than a longer one if both are running at the same speed. It follows that sprocket/tooth wear is directly proportional to speed. Sprockets with more teeth cause less module/hinge rotation, consequently less wear than sprockets with fewer teeth.

2. Belt surface wear: As belts slide over carryways, returnways, shoes and other fixed members, some wear is to be expected. The most destructive conditions are high speed, heavy loads, abrasive materials, and dry or non lubricated operation.
3. Dynamic effects of high speed operation: Two effects of high speed conditions are belt “whipping” or oscillating in unsupported sections and “load surges” as heavy, stationary products are suddenly accelerated to belt speed. Where possible, both conditions should be avoided.

ABRASIVE CONDITIONS AND FRICTION EFFECTS

Abrasives in a conveying application must be identified, the best combination of materials chosen and protective features included in order to extend belt life. Abrasives will wear away any material, but the correct material choice can significantly increase belt life. In highly abrasive applications, the hinge rods and sprockets are usually the first elements to be affected. Hinge rod wear typically results in excessive belt-pitch elongation. This may prevent proper tooth engagement, increasing the wear on sprocket teeth. Intralox offers Stainless Steel split sprockets and Abrasion Resistant rods that work to increase belt life.

CHORDAL ACTION AND SPROCKET SELECTION

As the modules of belts engage their driving sprockets, a pulsation in the belt’s linear velocity occurs. This is due to chordal action, which is the rise and fall of a module as it rotates around a shaft’s center line. It is characteristic of all sprocket-driven belts and chains. The variation in speed is inversely proportional to the number of teeth on the sprocket. For example, a belt driven by a six tooth sprocket has a pulsating speed variation of 13.4%, while a belt driven by a 19 tooth sprocket has a variation of only 1.36%. In those applications, where product tipping is a concern, or where smooth, even speed is critical, it is recommended that sprockets with the maximum number of teeth available be selected.

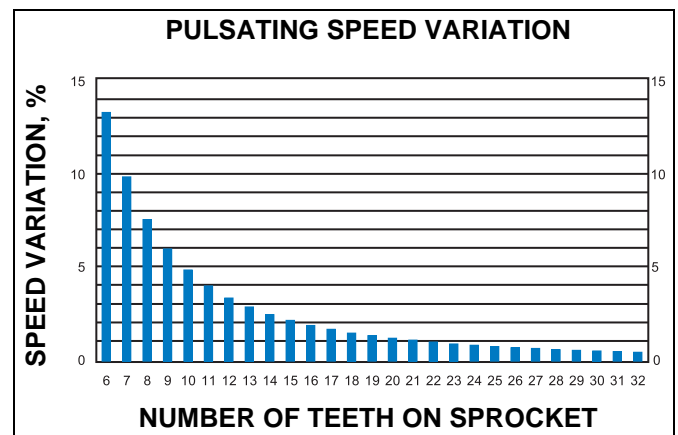

SHAFTS

Intralox, LLC USA can supply square shafts, machined to your specification, in standard sizes of 5/8 in., 1 in., 1.5 in., 2.5 in., 3.5 in., 40 mm and 60 mm. Available materials are Carbon Steel (C-1018) (not available in 40mm and 60mm), Stainless Steel (303, 304 and 316) and Aluminium (6061-T6). Call Customer Service for availability and lead-times.

Intralox, LLC Europe offers square shafts in standard sizes of 25 mm, 40 mm, 60 mm, 65 mm and 90 mm. Available materials are Carbon Steel (KG-37) and Stainless Steel (304).

Square shafts need turning of bearing journals only. No keyways for sprockets are required. Only one sprocket per shaft must be retained to prevent lateral belt movement and to provide positive tracking. This is usually done by placing

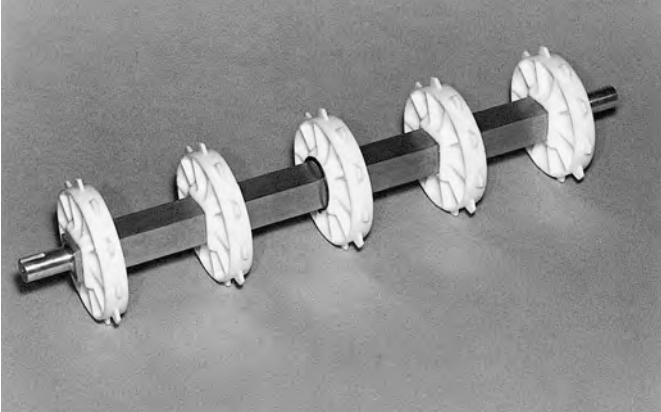

retainer rings on opposite sides of the center sprocket. Standard rings rest in grooves cut into the four corners of the shaft. Self-set retainer rings and small bore round retainer rings are available which do not require grooves.

SHAFT STRENGTH

The two primary concerns regarding the strength of the conveyor drive shafts are 1) the ability to pull the belt without excessive shaft deflection, and 2) the strength to transmit the torque for driving the belt. In the first case, the shaft acts as a

beam, supported by bearings and stressed by the belt's tension through the sprockets. In the second case, the shaft is being rotated by the drive motor. Resistance from the belt's tension introduces torsional (twisting) stresses. These two types of stresses, maximum deflection and maximum allowable torque, are analyzed separately. Simple formulas are provided for selecting appropriate shafts.

Maximum deflection is governed by adequate belt and sprocket tooth engagement. If the shaft deflects more than 0.10 in. (2.5 mm) the sprockets may not engage properly, resulting in "jumping". On bi-directional conveyors with center-drive, the limit is increased to 0.22 in. (5.6 mm) because the return side tension is greater and the tooth loading is more uniformly distributed.

WEARSTRIPS

Wearstrips are added to a conveyor frame to increase the useful life of the conveyor frame and belt, and to reduce the sliding friction forces. Proper choice of wearstrip design and material, yielding the best coefficient of friction, reduces belt and frame wear, and power requirements.

Any clean liquid, such as oil or water, will act as a coolant and as a separation film between the belt and the carryway, usually reducing the coefficient of friction. Abrasives such as salt, broken glass, soil and vegetable fibers will embed in softer materials and wear on harder materials. In such applications harder wearstrips will prolong belt life.

STATIC ELECTRICITY

Plastic belting may produce a static discharge or spark when used in a dry environment. If static electricity is a potential problem in your application, electrical grounding is recommended. Lubricating or adding moisture to the conveyor running surfaces is also recommended. Electrically Conductive Acetal is available in some belt styles. Contact the Intralox Sales Engineering Department for additional recommendations.

INTRALOX SERVICES

ENGINEERING ASSISTANCE AND DESIGN REVIEW • To obtain engineering assistance, or to request a design review, call the Intralox Sales Engineering Department^a.

ENGINEERING ANALYSIS COMPUTER PROGRAMS • Intralox offers a PC based Engineering Program for all belts used in straight running applications that will calculate belt pull, sprocket requirements, motor and drive information, etc. Call Customer Service^a to request these programs.

CAD DRAWING FILES • Auto CAD.DXF templates for all Series are also available. The templates have belt and molded sprocket details which can be used in CAD conveyor designs. Call Customer Service^a for more information.

PRODUCT LITERATURE • Intralox offers additional technical and application specific literature on most of the products listed in this manual. Call Customer Service^a for more information.

WORLD WIDE WEB • For information on Intralox products, our company or to download the Intralox[®] Engineering Program, or to download the Engineering Manual on line, visit the Intralox web site at www.intralox.com.

a. See back cover for international listings.

SECTION TWO: PRODUCT LINE

STANDARD BELT MATERIALS

ACETAL

A thermoplastic that is considerably stronger than polypropylene and polyethylene, and has a good balance of mechanical and thermal properties.

- Good fatigue endurance and resilience.
- Low coefficient of friction, making it a good choice for container handling and transport.
- Temperature range is -50 °F (-46 °C) to 200 °F (93 °C).
- Specific gravity is 1.40 and relatively impact resistant.
- Acetal belts are fairly hard, so they are relatively cut and scratch resistant.
- Anti Static Acetal (AS Acetal) is available for applications where a slow static buildup has to be dissipated. With AS acetal, this dissipation is slow and improves in a humid environment. Anti Static Acetal is currently available in Series 400 Non Skid.

POLYETHYLENE

A lightweight thermoplastic, is characterized by superior flexibility and high impact strength.

- Buoyant in water, with a specific gravity of 0.95.
- Excellent product release characteristics.

- Exhibits excellent performance at much lower temperatures.
- Temperature range is -100 °F (-73 °C) to 150 °F (66 °C). (Check belt specifications for exact figures).
- Resistant to many acids, bases and hydrocarbons.
- Black polyethylene is recommended for low temperature applications exposed to direct sunlight.

POLYPROPYLENE

A standard material for use in general applications and where chemical resistance may be required.

- Good balance between moderate strength and lightweight.
- Buoyant in water, with a specific gravity of 0.90.
- Temperature range is 34 °F (1 °C) to 220 °F (104 °C).
- A relatively strong material in normal use, polypropylene exhibits a somewhat brittle quality at low temperatures. It is not recommended in high impact conditions below 45 °F (7 °C).
- Good chemical resistance to many acids, bases, salts and alcohols.
- Black polypropylene is recommended for applications exposed to direct sunlight.

SPECIAL APPLICATION BELT MATERIALS

ABRASION RESISTANT (AR) NYLON

This material is available only for Series 1700.

- For abrasive (wet and dry), heavy-duty applications.
- Available in Black and White which are both FDA approved.
- Temperature range is -50 °F to 240 °F (-46 °C to 116 °C).
- 0.5% expansion in belt width at 100% relative humidity.
- Specific gravity of 1.06
- Heat stabilized for superior outdoor wear.
- Uses the same temperature factor table as regular Nylon.

CRFR

An engineered material optimized for food processing where a high degree of chemical resistance is required. One application in particular are continuous use antimicrobial dip tanks which utilize chemicals like peracetic acid (PAA).

- Exceptional resistance to strong acids.
- Highly resistant to other sanitation chemicals, salts, alcohols, and oxidants.
- Resistant to ozone, radiation, and UV.
- Tough and durable, even after continuous chemical exposure.
- Extremely hydrophobic compared to other plastics or metals.
- Temperature range is 0°F (-18°C) to 150°F (66°C)
- The specific gravity is 1.77-1.79.

DETECTABLE ACETAL

This material was developed for applications in the food processing industry where product contamination is a concern. It is designed to be detectable by metal or x-ray detectors and used upline from metal or x-ray detectors. It is specially formulated to enhance impact resistance.

- Metal filled material will not rust or expose hazardous sharp fibers.
- Temperature range is -50 °F to 200 °F (-46 °C to 93 °C).
- Material has good impact resistance for temperatures above 34 °F (1 °C).
- Testing the material on a metal detector in a production environment is the best method for determining detection sensitivity.
- Available in select styles across a wide range of belt series. Contact Customer Service for availability.

DETECTABLE NYLON

This material was developed for applications in food-processing industries where product contamination is a concern. This belt material is designed to be detectable by metal detectors and x-ray machines and should be used upstream from these machines.

- Available for Series 1700 belts.
- For abrasive (wet and dry), heavy-duty applications.
- Temperature range is -50 °F (-46 °C) to 180 °F (82 °C).
- 0.5% expansion in belt width at 100% relative humidity.

- Specific gravity: 1.06.
- Uses the same temperature factor table as regular Nylon.
- Metal-filled material will not rust or expose hazardous sharp fibers.
- The thermal expansion coefficient is 0.00072 in./ft/ °F (0.11 mm/m/ °C)
- Testing the material on a metal detector in a production environment is the best method for determining detection sensitivity.

DETECTABLE POLYPROPYLENE

This material was developed for applications in the food processing industry where product contamination is a concern. It is designed to be detectable by metal detectors or x-ray machines and used upline from metal or x-ray detectors. It is specially formulated to enhance impact resistance.

- Temperature range is 0 °F (-18 °C) to 150 °F (66 °C)
- Metal filled material will not rust or expose hazardous sharp fibers.
- Buoyant in water, with a specific gravity of 0.96
- Material has good impact resistance for temperatures above 34 °F (1 °C)
- Testing the material on a metal detector in a production environment is the best method for determining detection sensitivity.
- The thermal expansion coefficient is 0.0011 in/ft/ °F (0.17 mm/m/ °C)
- The detectable material has Surface Resistivity per ASTM D257 of 545 Ohms per square.
- Available in select styles across a wide range of belt series. Contact Customer Service for availability.

DETECTABLE POLYPROPYLENE A22

This material was developed for applications in the food processing industry where product contamination is a concern. It is designed to be detectable by metal detectors or x-ray machines and used upline from metal or x-ray detectors. It is specially formulated to enhance impact resistance.

- Temperature range is 0°F (-18°C) to 150°F (66°C)
- Metal filled material will not rust or expose hazardous additives.
- The specific gravity is 1.13.
- Material has good impact resistance for temperatures above 34°F (1°C)
- Testing the material on a metal detector in a production environment is the best method for determining detection sensitivity.
- The thermal expansion coefficient is 0.0011 in/ft/°F (0.17 mm/m/°C)
- Available in select styles across a wide range of belt series. Contact Intralox Customer Service for availability.

EASY RELEASE PLUS

This material was developed to resist rubber sticking and maintain dimensional stability in the presence of oils and high temperatures targeted for applications in the tire industry.

- Temperature range is 34 °F (1 °C) to 220 °F (104 °C).
- The thermal expansion coefficient is 0.0004 in/ft/ °F (0.06 mm/m/ °C)
- Easy Release PLUS is available in Series 1400 Flat Top.

EASY RELEASE TRACEABLE POLYPROPYLENE

This material was developed to resist rubber sticking and offer metal detectability for tire applications where stickiness and product contamination can be problematic.

- Temperature range is 34 °F (1 °C) to 220 °F (104 °C).
- Easy Release Traceable Polypropylene is available in Series 1400 Flat Top.

ELECTRICALLY CONDUCTIVE (EC) ACETAL

This material can be used to help dissipate static charges that might build up, especially when moving cans or other conductive objects. A metal railing or carryway can be used to ground the belt, dissipating any charge built up in the product. EC Acetal is usually spliced into “normal” belt sections (three rows of EC Acetal for every 2 ft. (0.61 m) of belt for Series 100 and Series 900, five rows for every 2 ft. (0.61 m) of belt for Series 1100), though entire belts can be made from EC Acetal.

- The chemical resistance and friction factors match those of regular acetal.
- EC Acetal has a surface resistivity of 1000 Ohms according to IEC 60093.
- Its specific gravity is 1.40.
- EC Acetal is only available in Series 100 Flush Grid, Series 400 Flush Grid and Flat Top, Series 900 Flush Grid, Flat Top and Raised Rib, Series 1100 Flush Grid, and Series 1400 Flat Top belt styles.

ENDURALOX™ POLYPROPYLENE

A specially formulated material designed to maximize the life of Intralox belting in a pasteurizer environment by protecting the molecular structure of the polypropylene from environmental factors such as temperature cycling, bromine, and chlorine.

- Same physical properties as standard polypropylene.

FLAME RETARDANT THERMOPLASTIC POLYESTER (FR-TPES)

This material is V-0 rated (UL94 @ 1/32"), and will not sustain a flame. Though the material will not actively burn, it will blacken and melt in the presence of flame. FR-TPES is stronger than polypropylene, but not as strong as acetal.

- V-0 rated (UL94 @ 1/32").
- FR-TPES' temperature range is 40 °F (4 °C) to 150 °F (66 °C).
- FR-TPES has a specific gravity of 1.45.
- FR-TPES is available in Series 1100 Flush Grid, Series 900 Flush Grid, Series 900 Flush Grid ONEPIECE™ Live Transfer and Series 900 Perforated Flat Top.

HEAT RESISTANT (HR) NYLON

This material is available for dry, elevated temperature applications and complies with FDA regulations for use in food processing and packaging applications.

- UL94 flammability rating of V-2.
- Upper, continuous temperature limit of 240 °F (116 °C). For intermittent exposure, HR Nylon has a rating limit of 270 °F (132 °C).
- The specific gravity is 1.13.
- This material will absorb water in wet environments, causing the belt to expand. The belt will also expand due to the

temperature change. The thermal expansion coefficient is 0.00054 in/ft/°F (0.081 mm/m/°C).

HI-IMPACT

This material is available only for S800 Tough Flat Top. This material was developed for applications in the food processing industry where extreme impacts are a concern.

- Temperature range is 0 °F (-18 °C) to 120 °F (49 °C).
- Specific gravity of 1.18
- The thermal expansion coefficient is 0.001 in/ft/°F (0.156 mm/m/ °C)
- Greater impact resistance than acetal and polypropylene

HIGH HEAT RESISTANT (HHR) NYLON

This material is available for dry, elevated temperature applications and complies with FDA regulations for use in food processing and packaging applications.

- UL94 flammability rating of V-2.
- Upper, continuous temperature limit of 310 °F (154 °C). For intermittent exposure, HHR Nylon is rated at 360 °F (182 °C).
- The specific gravity is 1.13.
- This material will absorb water in wet environments, causing the belt to expand. The belt will also expand due to the temperature change. The thermal expansion coefficient is 0.00054 in/ft/°F (0.081 mm/m/°C).

NYLON

This material is available for applications requiring good dry abrasion and chemical resistance. The two limitations to Nylon are that it absorbs water and is more susceptible to cuts and gouges than acetal. Because of material expansion caused by water absorption, Nylon is not recommended for very wet applications. For example, at 100% relative humidity, the expansion will be close to 3% (at equilibrium), making a 24 in. (610 mm) wide belt expand to 24.75 in. (629 mm).

- Abrasion resistant in dry applications.
- Good chemical resistance and low temperature performance.
- Stronger than polypropylene.
- Temperature range is -50 °F (-46 °C) to 180 °F (82 °C).
- Good fatigue resistance.
- Specific gravity of 1.13.

POLYPROPYLENE COMPOSITE

A standard material for use in applications where both high strength and chemical resistance may be required.

- Excellent strength and stiffness.
- Specific gravity of 1.12.
- Good chemical resistance to acids, bases, salts and alcohol.
- Temperature range is -20 °F (-29 °C) to 220 °F (104 °C).
- An EC (Electrically Conductive) PP Composite can be used to help dissipate static charges that might build up. The EC PP Composite is currently available in Series 1200 Non Skid.
- The thermal expansion coefficient is 0.0004 in/ft/ °F (0.06 mm/m/ °C).

PVDF

A specialty material with excellent chemical resistance to a wide variety of acids and bases.

- Excellent resistance to acids, bases, salts, and alcohol.

- Specific gravity of 1.78.
- Temperature range is -34 °F (1 °C) to 200 °F (93 °C).
- PVDF is currently available in Series 9000 Flush Grid.
- V-0 rated (UL94 @ 1/32 in.)
- Stronger than polypropylene.
- The thermal expansion coefficient is 0.00120 in/ft/ °F (0.18 mm/m/ °C).

SELF EXTINGUISHING LOW MOISTURE (SELM)

This material is a polymer engineered for use in the Spiralox family of belts. SELM's Self Extinguishing characteristics are important to customers who want to reduce the risk of fires in their plants. SELM's Low Moisture absorption characteristics are particularly important to customers who want a material that will perform in humid conditions and applications that require cleaning.

- Continuous temperature range is -50 °F (-46 °C) to 240 °F (116 °C).
- UL94 V-2 flammability rating
- Specific Gravity is 1.06
- Uses the same temperature factor table as regular Nylon.

UFVR

This material does not sustain a flame.

- Excellent resistance to ultraviolet radiation.
- Specific gravity of 1.78
- Temperature range is -34 °F (1 °C) to 200 °F (93 °C).
- UVFR is currently available in Series 1100 Flush Grid and Series 900 Perforated Flat Top.
- V-O rated (UL94 @ 1/32 in.)
- The thermal expansion coefficient is 0.00087 in/ft/°F (0.13 mm/m/°C).

UV RESISTANT

UV resistant acetal and black polypropylene are available for applications that require UV protection.

- UV Resistant acetal temperature range is -50°F (-46°C) to 200°F (93°C).
- UV Resistant polypropylene temperature range is 34°F (1°C) to 220°F (104°C).

X-RAY DETECTABLE ACETAL

This material is designed specifically to be detected by x-ray machines. Developed for applications in the food processing industry where product contamination is a concern.

- To be used upline from an x-ray detector.
- Temperature range is -50 to 200°F (-46 to 93°C).
- Stronger than polypropylene and polyethylene, with a good balance of mechanical, thermal, and chemical properties.
- Has the same chemical resistance as regular acetal.
- The thermal expansion coefficient is 0.0007 in/ft/°F (0.10 mm/m/°C).
- Testing the material with an x-ray detector in a production environment is the best method for determining detection sensitivity.
- Available in Series 800 SeamFree Open Hinge Flat Top and Series 1500 Flush Grid.
- Contact Intralox Customer Service for conveyor design recommendations when using x-ray detectable material.

BELT MATERIAL PROPERTIES

SPECIFIC GRAVITY

This value is the ratio of the material's density to the density of water at normal pressures and temperatures. A specific gravity greater than 1.0 indicates that the material is heavier than water, and a specific gravity less than 1.0 indicates the material will be buoyant in water.

MATERIAL	SPECIFIC GRAVITY
Polypropylene	0.90
Polypropylene Composite	1.12
Polyethylene	0.95
Acetal	1.40
EC Acetal	1.40
FR-TPES	1.45
Nylon	1.13
HR & HHR Nylon	1.13

FRICTION FACTORS

These factors determine the amount of drag induced from the belt sliding on the conveyor frame or sliding under the conveyed product. Lower friction factors lead to lower line pressures, less product marring, and lower belt pull and power requirements. Sometimes higher friction is required for gradual inclines/declines or for higher line pressures for feeding other equipment. The friction factors generally refer to "clean" systems, with little wear or abrasive material present. When running a conveyor belt strength analysis (either by using the Intralox Engineering Program or by using the hand calculations outlined in "Belt Selection Instructions" (page 20)), normal practice would dictate using a higher friction factor than normal if any abrasive medium is present, such as flour, sand, cardboard dust, glass, etc. Under very dirty conditions, friction factors may be two to three times higher than under clean conditions.

TEMPERATURE

Temperature has an effect on the physical properties of thermoplastic materials. Generally, as the operating temperature increases, the belt will weaken in strength, but become tougher and more impact resistant. Conversely, in colder applications, belts can become stiffer and in some cases brittle. The temperature factor curve shows the effect of temperature on belt strength, and this graph can be used in calculating the conveyor belt analysis by hand. The Intralox Engineering Program calculates the temperature factor automatically, based on the operating temperature of the application. For a complete listing of temperature factors (T), please refer to "Table 7 (T) TEMPERATURE FACTOR" (page 456).

T

TEMPERATURE FACTOR TABLES STANDARD MATERIALS

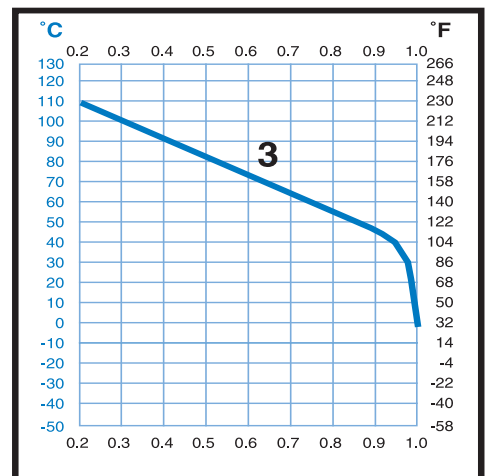
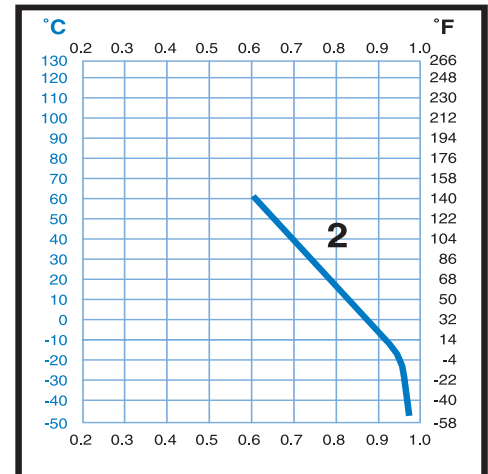
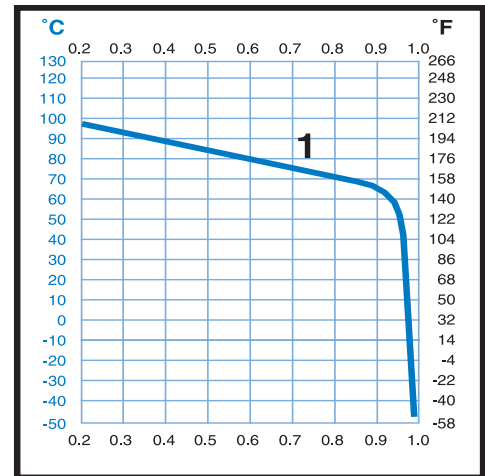

- 1 -Acetal and EC Acetal
- 2 -Polyethylene
- 3 -Polypropylene

FRICTION FACTORS

Friction Factors ^a	F_w Friction between wearstrip and belt Wearstrip material				F_p Friction between product and belt Product material (used in backup conditions) ^b				
	UHMW WET (DRY)	HDPE WET (DRY)	NYLATRON WET (DRY)	STEEL (CS & SS) WET (DRY)	GLASS WET (DRY)	STEEL WET (DRY)	PLASTIC WET (DRY)	CARDBOARD WET (DRY)	ALUMINUM WET (DRY)
Polypropylene (S)	0.11 (0.13)	0.09 (0.11)	0.24 (0.25)	0.26 (0.26)	0.18 (0.19)	0.26 (0.32)	0.11 (0.17)	— (0.21)	0.40 (0.40)
Polypropylene (A)	NR	NR	0.29 (0.30)	0.31 (0.31)	0.18 (0.19)	0.26 (0.32)	0.11 (0.17)	— (0.21)	0.40 (0.40)
PP Composite (S)	0.30 (0.35)	—	—	0.31 (0.37)	0.24 (0.23)	0.36 (0.32)	0.17 (0.21)	—	0.55 (0.45)
Polyethylene ^c (S)	0.24 (0.32)	NR	0.14 (0.13)	0.14 (0.15)	0.08 (0.09)	0.10 (0.13)	0.08 (0.08)	— (0.15)	0.20 (0.24)
Detectable PP	0.24 (0.27)	NR	0.28 (0.29)	0.26 (0.30)	0.18 (0.20)	0.26 (0.30)	0.26 (0.29)	— (0.37)	0.40 (0.40)
Detectable Nylon Max. Temp.	(S) — (0.19)	— (0.11)	— (0.24)	— (0.31)	—	—	—	— (0.22)	— (0.31)
	(A) — (0.32)	— (0.22)	— (0.36)	— (0.30)	—	—	—	— (0.22)	— (0.31)
Acetal (S)	0.10 (0.10)	0.09 (0.08)	0.13 (0.15)	0.18 (0.19)	0.13 (0.14)	0.13 (0.13)	0.13 (0.16)	— (0.18)	0.33 (0.27)
HSEC Acetal (S)	0.10 (0.10)	0.09 (0.08)	0.13 (0.15)	0.18 (0.19)	0.13 (0.14)	0.19 (0.20)	0.13 (0.16)	— (0.18)	0.33 (0.27)
FR-TPES (S)	— (0.13)	—	—	—	—	— (0.18)	—	—	— (0.30)
HR Nylon 72 °F (22 °C)	(S) — (0.18)	— (0.13)	— (0.17)	— (0.27)	— (0.16)	— (0.27)	— (0.16)	— (0.19)	— (0.28)
	(A) — (0.30)	— (0.25)	— (0.26)	— (0.26)	— (0.16)	— (0.27)	— (0.16)	— (0.19)	— (0.28)
HR Nylon Max. Temp.	(S) NR	NR	— (0.18)	— (0.27)	— (0.19)	— (0.27)	— (0.47)	— (0.23)	— (0.25)
	(A) NR	NR	— (0.32)	— (0.39)	— (0.19)	— (0.27)	— (0.47)	— (0.23)	— (0.25)
AR Nylon Max. Temp.	(S) — (0.19)	— (0.11)	— (0.24)	— (0.31)	—	—	—	— (0.22)	— (0.31)
	(A) — (0.32)	— (0.22)	— (0.36)	— (0.30)	—	—	—	— (0.22)	— (0.31)
UV Resistant PP	0.11 (0.13)	0.09 (0.11)	0.24 (0.25)	0.26 (0.26)	0.18 (0.19)	0.26 (0.32)	0.11 (0.17)	— (0.21)	0.40 (0.40)
PVDF	-	-	-	0.20 (0.20)	-	0.20 (0.20)	-	-	0.15 (0.15)
Hi-Impact	0.23 (0.21)	-	-	0.31 (0.33)	-	— (0.64)	-	-	-
Easy Release PLUS	(S) 0.11 (0.13)	0.09 (0.11)	0.24 (0.25)	0.26 (0.26)	—	—	—	—	—
(SELM)	(S) — (0.19)	— (0.11)	— (0.24)	— (0.31)	—	—	—	— (0.22)	— (0.31)
	(A) — (0.32)	— (0.22)	— (0.36)	— (0.30)	—	—	—	— (0.22)	— (0.31)

(S) = smooth, clean conditions. (A) = abrasive, dirty conditions. NR = not recommended.

- Friction factor values are highly dependent on environmental conditions. The low value of the friction factor range is an experimentally derived friction factor for new belting on new wearstrip. This value should only be used in the cleanest environments or where water or other lubricating agents are present. Most applications should be adjusted based on the environmental conditions surrounding the conveyor.
- Friction Factors for friction between product and belt only apply for Flat Top, Perforated Flat Top, Mesh Top, Flush Grid and Raised Rib belts.
- Polyethylene is not recommended for container handling.

BELT MATERIAL COMPLIANCE

FDA COMPLIANT

The material meets the FDA requirements described in the applicable Code of Federal Regulations, Chapter 21, Part 177 as noted. The material is chemically acceptable to the USDA for repeat use applications in slaughtering, processing, transporting, and storage areas in direct contact with meat or poultry products.

3A DAIRY TESTED

This test is based upon materials, not product design. In accelerated use testing, the materials show that when they are cleaned and sanitized they maintain essential functional properties and surface finish.

EU COMPLIANT

The material complies with the framework regulation 1935/2004/EC. The monomers and additives used to make the plastic are listed in the Union List. When tested to the criteria described in EU Regulation 10/2011, the finished article did not exceed the overall migration limit (OML) and any applicable specific migration limits (SML).

BELT MATERIAL COMPLIANCE ^a			
Material Name	FDA Compliant	EU Compliant	3A Dairy Tested
Acetal	FCN 1573	1935/2004 EC, Regulation 10/2011	Not Tested
AR Nylon	21 CFR 177.1500	1935/2004 EC, Regulation 10/2011	Not Tested
CRFR	21 CFR 177.2510	1935/2004 EC, Regulation 10/2011	Not Tested
Detectable Acetal	21 CFR 177.2470	1935/2004 EC, Regulation 10/2011	20-25
Detectable Nylon	21 CFR 177.1500	Not compliant due to sizing agent	Not Tested
Detectable Polypropylene A22	21 CFR 177.1520	1935/2004 EC, Regulation 10/2011	20-27
Enduralox Polypropylene	21 CFR 177.1520	1935/2004 EC, Regulation 10/2011	Not Tested
HR Nylon	21 CFR 177.1500	1935/2004 EC, Regulation 10/2011	Not Tested
HHR Nylon	21 CFR 177.1500	1935/2004 EC, Regulation 10/2011	Not Tested
Hi-Impact	21 CFR 177.2600	1935/2004 EC, Regulation 10/2011	Not Tested
Hi-Temp	21 CFR 177.2415	1935/2004 EC, Regulation 10/2011	Not Tested
Nylon	21 CFR 177.1500	1935/2004 EC, Regulation 10/2011	Not Tested
Polyethylene	21 CFR 177.1520	1935/2004 EC, Regulation 10/2011	20-23
Polypropylene	21 CFR 177.1520	1935/2004 EC, Regulation 10/2011	20-25
Polypropylene Composite	21 CFR 177.1520	1935/2004 EC, Regulation 10/2011	Not Tested
SELM	21 CFR 177.1500	1935/2004 EC, Regulation 10/2011	Not Tested
X-Ray Detectable Acetal	21 CFR 177.2470	1935/2004 EC, Regulation 10/2011	Not Tested

a. Contact Intralox Customer Service to verify compliance for specific belt series, styles, and material color combinations for specific applications.

GENERAL APPLICATION SPROCKET MATERIAL

ACETAL

These sprockets are used for most general purpose applications. This material is considerably stronger than polypropylene and polyurethane, and has a good balance of mechanical, thermal and chemical properties.

- Acetal has good fatigue endurance and resilience.
- Acetal has good non abrasive wear characteristics.
- Acetal's temperature range is -50 °F (-46 °C) to 200 °F (93 °C).
- This material is FDA compliant for use in food processing and packaging applications.

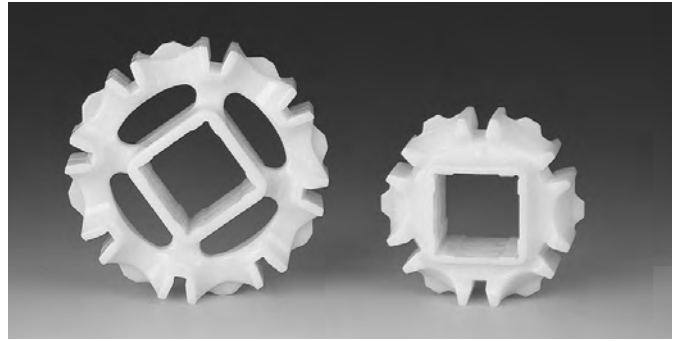

SPECIAL APPLICATION SPROCKET MATERIAL

ABRASION RESISTANT NYLON

These sprockets are used in abrasive applications.

- Temperature range is -50 °F (-46 °C) to 240 °F (116 °C).

GLASS FILLED NYLON

These sprockets are available for Series 900, Series 1100, Series 1400, Series 2400, Series 4000, and Series 4500. This material is more abrasion resistant than Acetal but not as abrasion resistant as Stainless Steel. Temperature range of Glass Filled Nylon is -51 °F (-46 °C) to 240 °F (116 °C); Not chemical resistant.

GLASS FILLED NYLON WITH POLYPROPYLENE JOINING PLATE

These sprockets are available in Series 900. The glass filled nylon tooth plate is assembled with a Polypropylene joining plate that forms the hub of the sprocket. The temperature range for the two material sprocket is 34 °F (1 °C) to 220 °F (104 °C). A relatively strong material in normal use, polypropylene exhibits a somewhat brittle quality at low temperatures. It is not recommended in high impact conditions below 45 °F (7 °C).

POLYURETHANE COMPOSITE SPLIT

These sprockets are available in Series 400. The Polyurethane Composite Split sprocket consists of one polyurethane composite tooth plate assembled between Polypropylene joining plates that form the hub of the sprocket. The temperature range for Polyurethane Composite is -50 °F (-46 °C) to 240 °F (116 °C). It is recommended for Drive Shaft only. The sprocket is split into two pieces for easy assembly onto and off the shaft. A relatively strong material in normal use, polypropylene exhibits a somewhat brittle quality at low temperatures. It is not recommended in high impact conditions below 45 °F (7 °C).

POLYETHYLENE

These sprockets are available for the Series 3000 and some Series 2600 sprockets.

Note: Not all sprocket pitch diameters, bore sizes and material combinations are available in all series. Those that are available can either be stocked or made to order. Contact Intralox Customer Service for availability and lead-times (some available combinations may be long lead-time items).

POLYPROPYLENE

These sprockets are used for applications where chemical resistance may be required.

- Polypropylene has good chemical resistance to many acids, bases, salts and alcohols.
- Polypropylene's temperature range is 34 °F (1 °C) to 220 °F (104 °C).
- A relatively strong material in normal use, polypropylene exhibits a somewhat brittle quality at low temperatures. It is not recommended in high impact conditions below 45 °F (7 °C).
- This material is FDA compliant for use in food processing and packaging applications.
- Contact Intralox Customer Service for polypropylene sprocket availability.

POLYPROPYLENE COMPOSITE

This is a standard material for use in applications where both high strength and chemical resistance may be required.

- Excellent strength and stiffness.
- Specific gravity of 1.12.
- Good chemical resistance to acids, bases, salts and alcohol.
- Temperature range is -20 °F (-29 °C) to 220 °F (104 °C).
- The thermal expansion coefficient is 0.0004 in/ft/ °F (0.06 mm/m/ °C).

POLYURETHANE

These sprockets are used for applications where abrasive wear is common.

- Polyurethane's temperature range is 0 °F (-18 °C) to 120 °F (49 °C). Polyurethane becomes soft and flexible at high temperatures and has good chemical resistance.
- Series 800, 1600, 2200 and 2400 have a lower rating when using polyurethane sprockets. Refer to the individual belt data pages for these ratings.

POLYURETHANE COMPOSITE

These sprockets are standard in Series 1200 and one size in Series 1400 (31 Tooth). This material is extremely rigid and can handle a large range of chemicals and temperatures. The temperature range for Polyurethane Composite is -50 °F (-46 °C) to 240 °F (116 °C).

STAINLESS STEEL

These split sprockets are used for applications with abrasive wear or when shaft removal is not practical. There are two types of stainless steel sprockets. The all-metal Abrasion Resistant sprockets are available in a number of Series and Pitch Diameters. The Stainless Steel Split consists of 1 to 3 stainless steel tooth plates assembled between polypropylene joining plates that form the hub of the sprocket.

- The sprocket is split into two pieces for easy assembly onto and off of a shaft.
- Stainless steel split sprockets have good chemical resistance.
- Polypropylene's temperature range is 34 °F (1 °C) to 220 °F (104 °C).

- A relatively strong material in normal use, polypropylene exhibits a somewhat brittle quality at low temperatures. It is not recommended in high impact conditions below 45 °F (7 °C).
- These materials are FDA compliant for use in food processing and packaging applications.
- These sprockets are built standard with 304 stainless steel plates and can be specially ordered with 316 stainless steel plates.
- Contact Intralox Customer Service for availability.

ULTRA ABRASION RESISTANT POLYURETHANE

These sprockets are available for Series 400 and Series 1700.

- For abrasive, heavy-duty applications.
- For non-FDA applications.
- Temperature range -40 °F to 160 °F (-40 °C to 70 °C).
- Series 400 has a lower rating when using ultra abrasion resistant polyurethane sprockets.

SPROCKET MATERIAL AVAILABILITY

The chart below lists the materials available for each Intralox sprocket by Series and Pitch Diameter. It should be noted that not all sprockets of each pitch diameter are available in all listed materials. A material which is available for certain bore types and/or bore sizes may not be available for other bore types and/or bore sizes of the same Series and Pitch Diameter

sprocket. Sprockets can be either stocked or made to order, and may have long lead-times. Lead-times vary by sprocket. Some make to order sprockets may also have set up charges. Contact Intralox Customer Service for specific lead-times and availability.

		SPROCKET MATERIALS ^a										
		Acetal	Polypropylene	Split Metal	AR ^b Metal	AR ^b Nylon	Polyurethane	Glass Filled Nylon	Polyethylene	Polyurethane Composite	Ultra AR ^b Polyurethane	Polypropylene Composite
PITCH DIAMETER in (mm)	NO. TEETH											
S100												
2.0 (51)	6	•	•									
3.5 (89)	11	•	•	•			•					
6.1 (155)	19	•	•	•			•					
S200												
4.0 (102)	6	•	•				•					
6.4 (163)	10	•	•		•		•					
10.1 (257)	16	•	•		•							
S400												
4.0 (102)	6	•	•	•		•	•					
5.2 (132)	8	•	•									
5.8 (147)	9			• ^c								
6.4 (163)	10	•	•	•	•	•			•		•	
7.8 (198)	12	•	•	•	•	•			•		•	
8.4 (213)	13			• ^c								
10.1 (257)	16	•	•	•	•	•			•		•	
S550												
2.4 (61)	24	•										
3.2 (81)	32	•										
S800												
4.0 (102)	6	•	•				•					
5.2 (132)	8	•	•	• ^d			•					

		SPROCKET MATERIALS ^a										
		Acetal	Polypropylene	Split Metal	AR ^b Metal	AR ^b Nylon	Polyurethane	Glass Filled Nylon	Polyethylene	Polyurethane Composite	Ultra AR ^b Polyurethane	Polypropylene Composite
PITCH DIAMETER in (mm)	NO. TEETH											
6.5 (165)	10	•	•	• ^d		•				•		
7.7 (196)	12	•	•	• ^d		•				•		
10.3 (262)	16	•	•	• ^d						•		
S850												
4.0 (102)	6	•	•			•						
5.2 (132)	8	•	•	• ^d		•						
6.5 (165)	10	•	•	• ^d		•						
7.7 (196)	12	•	•	• ^d		•						
10.3 (262)	16	•	•	• ^d								
S888												
6.5 (165)	10	•				•						
7.7 (196)	12	•				•						
S900												
2.1 (53)	6	•	•									
3.1 (79)	9	•	•									
3.5 (89)	10	•	•	•								
4.1 (104)	12	•	•	•	•	•						
5.1 (130)	15			•				•				
5.8 (147)	17	•	•	•	•	•		•				
6.1 (155)	18	•	•	•	•	•		•				
6.8 (173)	20	•	•	•	•	•		•				
9.8 (249)	28			•								
S1000												
3.1 (79)	16	•										
4.6 (117)	24	•						•				•
6.1 (155)	32	•						•				•
S1100												
1.6 (41)	8					•						
2.3 (58)	12	•				•						
3.1 (79)	16	•	•									
3.5 (89)	18	•	•	•								
3.8 (97)	20	•	•									
4.6 (117)	24	•	•	•				•				
5.1 (130)	26	•	•	•								
6.1 (155)	32	•	•	•				•				
S1200												
5.6 (142)	12			•								
6.5 (165)	14			•						•		
7.4 (188)	16									•		
7.9 (201)	17									•		
10.2 (258)	22			•						•		
S1400												
3.9 (99)	12	•				•						
4.9 (124)	15	•										
5.1 (130)	16					•		•				
5.7 (145)	18	•				•		•				•
6.7 (170)	21							•				•
7.7 (196)	24	•				•						
9.9 (251)	31									•		•
S1500												
1.9 (48)	12	•										
2.3 (58)	14	•										
2.7 (69)	17	•										

		SPROCKET MATERIALS ^a										
		Acetal	Polypropylene	Split Metal	AR ^b Metal	AR ^b Nylon	Polyurethane	Glass Filled Nylon	Polyethylene	Polyurethane Composite	Ultra AR ^b Polyurethane	Polypropylene Composite
PITCH DIAMETER in (mm)	NO. TEETH											
6.5 (165)	10	•										
S2800												
6.3 (160)	13	•										
S2850												
6.2 (157)	13	•										
S2900												
6.2 (157)	13	•										
S2950												
6.2 (157)	13	•										
S3000												
5.2 (132)	8							•				
6.5 (165)	10							•				
7.7 (196)	12							•				
S4000												
3.9 (99)	12	•										
4.9 (124)	15	•										
5.1 (130)	16						•					
5.7 (145)	18	•					•					
6.7 (170)	21						•					
9.9 (251)	31									•		•
S4400												
4.0 (102)	6				•							
5.3 (135)	8				•							
6.5 (165)	10						•					
7.8 (198)	12						•					
10.3 (262)	16				•		•					
S4500												
6.5 (165)	10						•					•
7.8 (198)	12						•					•
10.3 (262)	16				•		•					•
S9000												
3.3 (84)	10				•							
4.2 (107)	13				•							
6.1 (155)	19				•							
6.5 (165)	20	•		•								•
8.1 (206)	25			•								•
12.9 (328)	40							•				•
S10000												
9.9 (251)	10				•							
11.8 (300)	12				•							
13.7 (348)	14				•							
15.7 (399)	16				•							

- a. All Intralox sprockets can be classified either as stock items or as make to order items. Some make to order items may incur special setup charges. Contact Intralox Customer Service for pricing, lead times, and availability.
- b. Abrasion Resistant
- c. For use with Series 400 Flush Grid Acetal and EC Acetal only.
- d. Available in three plate, Abrasion Resistant split design.

BELT SELECTION INSTRUCTIONS

To determine if this belt is suitable for your application, its **OPERATING LOAD** versus **OPERATING STRENGTH** must be known. The following steps will assist you in making the necessary calculations for this comparison:

STEP 1: CALCULATE THE BELT'S TENSION LOAD OR BELT PULL, BP, lb/ft (kg/m)

$$BP = [(M + 2W) \times F_w + M_p] \times L + (M \times H)$$

where:

- M** = Product Loading, lb/ft² (kg/m²)
- W** = Belt Weight, lb/ft² (kg/m²) (found on BELT DATA page)
- L** = Length of Conveyor, ft. (m), \mathcal{C} to \mathcal{C}
- H** = Elevation Change of Conveyor, ft. (m)
- F_w** = Wearstrip to Belt Friction Coefficient
- M_p** = **M** × (**F_p** × % Belt Backed-Up), loading due to backed up product

Obtain **F_w** and **F_p** from BELT DATA page of the belt style you are considering. If products are not backed up on belt, ignore **M_p**.

STEP 2: ADJUST THE CALCULATED BP FOR SPECIFIC SERVICE CONDITIONS

Since the belt may experience a variety of conditions, the BP should be adjusted by applying an appropriate Service Factor, SF.

Determine SF:

SERVICE FACTOR (SF)	
Starts under no load, with load applied gradually	1.0
Frequent starts under load (more than once per hour)	ADD 0.2
At speeds greater than 100 FPM (Feet Per Minute) (30 meters/min)	ADD 0.2
Elevating Conveyors	ADD 0.4
Pusher Conveyors	ADD 0.2
	TOTAL

Note: At speeds greater than 50 FPM (15 meters/min) on conveyors that are started with backed-up lines, soft start motors should be considered.

The Adjusted Belt Pull, ABP, is determined by:

$$ABP = BP \times SF$$

For Bi-Directional and Pusher Conveyors:

$$ABP = BP \times SF \times 2.2$$

where:

ABP = **ADJUSTED BELT PULL**, lb/ft (kg/m) of belt width

STEP 3: CALCULATE ALLOWABLE BELT STRENGTH, ABS lb/ft (kg/m) of belt width

The Allowable Belt Strength may, because of specific operating conditions, be less than the Rated Belt Strength shown on the Belt Data page. Therefore, the ABS should be calculated from:

$$ABS = BS \times T \times S$$

where:

- BS** = **BELT STRENGTH** from BELT DATA page.
- T** = **TEMPERATURE FACTOR** from page 12.
- S** = **STRENGTH FACTOR** from BELT DATA page. The Strength Factor is found at the intersection of the Speed/Length Ratio and the appropriate sprocket line. To get the Speed/Length Ratio, divide the belt speed (ft/min) by the shaft \mathcal{C} distance (ft). The Strength Factor adjusts the belt rating to account for wear caused by the combination of high speed, short conveyor lengths and small sprocket sizes.

STEP 4: COMPARE ABP WITH ABS

If the ABS exceeds ABP, this belt is strong enough for your application. You should proceed to the next steps to determine DRIVE SHAFT SPROCKET SPACING, SHAFT STRENGTH and HORSEPOWER REQUIRED.

If the ABS is less than ABP and you are able to change some parameters of your application (i.e., product load distribution or belt speed), the recalculated ABP may become acceptable.

STEP 5: DETERMINE MAXIMUM SPACING OF DRIVE SHAFT SPROCKETS

The percentage of ALLOWABLE BELT STRENGTH UTILIZED, ABSU, is determined by:

$$ABSU = (ABP \div ABS) \times 100\%$$

Using the ABSU, find the maximum sprocket spacing from the graph on the SPROCKET DATA page of the Series you are considering. The spacing of sprockets on idler shafts may, under some circumstances, be greater than drive spacing, but should never exceed 6.0 in. (152 mm) for all Series (except Series 200 where maximum spacing should never exceed 7.5 in. [191 mm]).

If the calculated ABSU is above 75%, please contact Intralox Customer Service Sales Engineering to run the Intralox Engineering Program and verify your results.

STEP 6: CONFIRM DRIVE SHAFT STRENGTH

Drive shafts must be stiff enough to resist excessive bending or deflecting under the belt's pull and strong enough to transmit the required torque from the driver. Therefore, both the DRIVE SHAFT DEFLECTION and TORQUE must be determined to ensure an adequate shaft selection.

Select a shaft size which fits your sprocket of choice from the Sprocket Data page.

Note: Most sprockets have more than one available bore size.

The shaft deflects under the combined loads of the ADJUSTED BELT PULL and its own WEIGHT. The TOTAL SHAFT LOAD, w , is found from:

$$w = (ABP + Q) \times B$$

where:

Q = SHAFT WEIGHT, lb/ft (kg/m), from SHAFT DATA table

B = BELT WIDTH, ft. (m)

For shafts supported by two bearings, the DEFLECTION, D , is calculated from:

$$D = \frac{5}{384} \times \frac{w \times L_s^3}{E \times I}$$

where:

L_s = LENGTH OF SHAFT between bearings, in. (mm)

E = MODULUS OF ELASTICITY from "Table 8 SHAFT DATA" (page 457).

I = MOMENT OF INERTIA from "Table 8 SHAFT DATA" (page 457).

Note: For shafts supported by three bearings, see "DEFLECTIONS WITH INTERMEDIATE BEARINGS" (page 448).

If the calculated deflection is less than the recommended maximum of 0.10 in. (2.5 mm) for standard conveyors or 0.22 in. (5.6 mm) for bi-directional units, calculate the required TORQUE. If not, use a larger size shaft, a stronger material or a shorter span between bearings, and recalculate the deflection.

The TORQUE, T_o , to be transmitted is determined from:

$$T_o = ABP \times B \times \frac{PD}{2}$$

where:

PD = PITCH DIAMETER OF SPROCKET from the SPROCKET DATA PAGE

Now compare T_o with the "Table 9 MAXIMUM RECOMMENDED TORQUE ON DRIVE SHAFT" (page 457), for shaft journal sizes shown. Using a journal diameter which can be machined on the shaft selected, determine its maximum recommended torque. This value should exceed T_o . If not, try a stronger material or larger shaft.

STEP 7: DETERMINE THE POWER NEEDED TO DRIVE THE BELT

DRIVE HORSEPOWER, HP, is found from:

$$HP = \frac{ABP \times B \times V}{33000}$$

where:

ABP = ADJUSTED BELT PULL, lb/ft of belt width

B = BELT WIDTH, ft.

V = BELT SPEED, ft/min

POWER in WATTS is found from:

$$WATTS = \frac{ABP \times B \times V}{6.12}$$

$$1 \text{ HP} = 745.7 \text{ WATTS}$$

where:

ABP = ADJUSTED BELT PULL, lb/ft of belt width

B = BELT WIDTH, ft.

V = BELT SPEED, ft/min

To obtain the required motor power you should add expected power losses in the drive train between drive shaft and motor to the calculated POWER. See "Section three: Design guidelines" (page 423), for recommendations.

Having determined the suitability of this belt, the sprocket spacing, the drive shaft size and the power requirements, you are now ready to select accessories and to design the conveyor assembly.

Flush Grid		
	in	mm
Pitch	1.00	25.4
Minimum Width	1.5	38
Width Increments	0.25	6.4
Opening Size (approximate)	0.2 x 0.2	5 x 5
Open Area	31%	
Hinge Style	Open	
Drive Method	Center-driven	
Product Notes		
<ul style="list-style-type: none"> • Contact Intralox for precise belt measurements and stock status before designing equipment or ordering a belt. • Lightweight, relatively strong belt with smooth upper surface. • Smaller pitch reduces chordal action and transfer dead plate gap. • Uses headed rods. • For more material selections and stronger belt performance, see Series 900 and Series 1100 Flush Grid styles. 		
Additional Information		
<ul style="list-style-type: none"> • See “Belt Selection Process” (page 5) • See “Standard Belt Materials” (page 9) • See “Special Application Belt Materials” (page 9) • See “Friction Factors” (page 13) 		

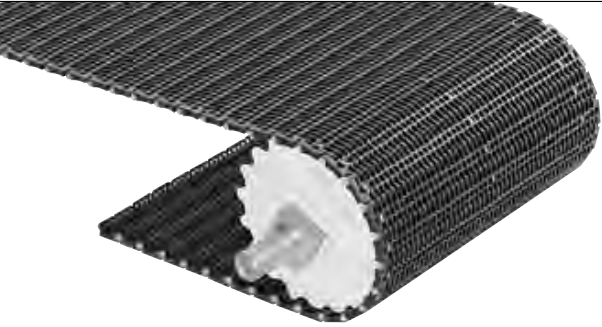
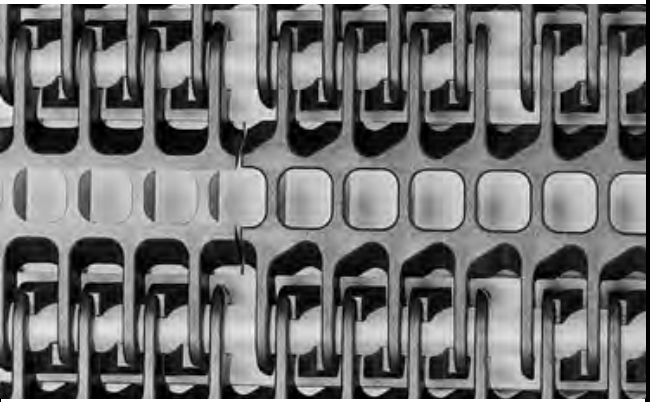
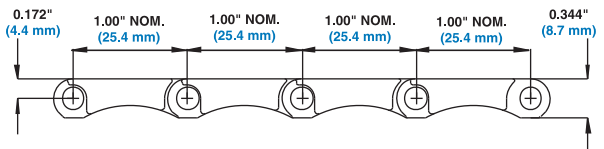



Belt Data							
Belt Material	Standard Rod Material Ø 0.18 in (4.6 mm)	BS Belt Strength		Temperature Range (continuous)		W Belt Weight	
		lb/ft	kg/m	°F	°C	lb/ft ²	kg/m ²
Polypropylene	Polypropylene	300	450	34 to 220	1 to 104	0.54	2.64
Polyethylene	Polyethylene	200	300	-50 to 150	-46 to 66	0.58	2.83
Acetal	Polypropylene	600	890	34 to 200	1 to 93	0.78	3.81
HSEC Acetal	Polypropylene	400	595	34 to 200	1 to 93	0.78	3.81
Acetal ^a	Polyethylene	550	820	-50 to 70	-46 to 21	0.78	3.81

a. Polyethylene rods can be used in cold applications when impacts or sudden starts/stops occur. Please note lower rating.

Raised Rib

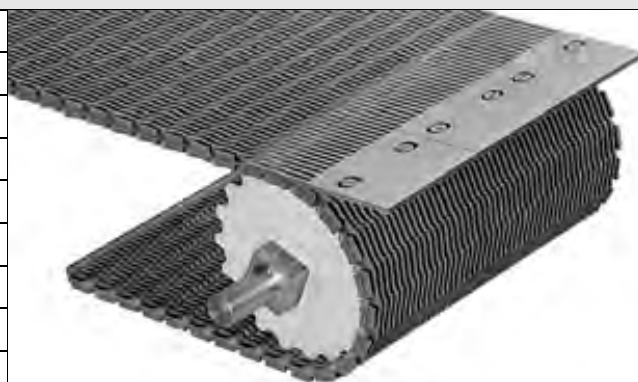
	in	mm
Pitch	1.00	25.4
Minimum Width	1.5	38
Width Increments	0.25	6.4
Opening Size (approximate)	0.2 x 0.2	5 x 5
Open Area	31%	
Product Contact Area	28%	
Hinge Style	Open	
Drive Method	Center-driven	



Product Notes

- **Contact Intralox for precise belt measurements and stock status before designing equipment or ordering a belt.**
- Smooth upper surface with closely spaced ribs can be used with finger transfer plates, eliminating product tippage and hang-ups.
- Uses headed rods.
- For more material selections and stronger belt performance, see Series 900 Raised Rib.



Additional Information

- See "Belt Selection Process" (page 5)
- See "Standard Belt Materials" (page 9)
- See "Special Application Belt Materials" (page 9)
- See "Friction Factors" (page 13)

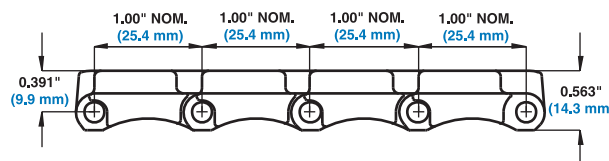

Belt Data

Belt Material	Standard Rod Material Ø 0.18 in (4.6 mm)	BS		Temperature Range (continuous)		W	
		Belt Strength		°F	°C	Belt Weight	
		lb/ft	kg/m			lb/ft ²	kg/m ²
Polypropylene	Polypropylene	300	450	34 to 220	1 to 104	0.82	4.00
Polyethylene	Polyethylene	200	300	-50 to 150	-46 to 66	0.88	4.29
Acetal	Polypropylene	600	890	34 to 200	1 to 93	1.20	5.86
Acetal ^a	Polyethylene	550	820	-50 to 70	-46 to 21	1.20	5.86

a. Polyethylene rods can be used in cold applications when impacts or sudden starts/stops occur. Please note lower rating.

Sprocket and Support Quantity Reference				
Belt Width Range ^a		Minimum Number of Sprockets Per Shaft ^b	Wearstrips	
in.	mm		Carryway	Returnway
2	51	1	2	2
4	102	1	2	2
6	152	2	2	2
7	178	2	3	2
8	203	2	3	2
10	254	2	3	2
12	305	3	3	2
14	356	3	4	3
15	381	3	4	3
16	406	3	4	3
18	457	3	4	3
20	508	5	5	3
24	610	5	5	3
30	762	5	6	4
32	813	7	7	4
36	914	7	7	4
42	1067	7	8	5
48	1219	9	9	5
54	1372	9	10	6
60	1524	11	11	6
72	1829	13	13	7
84	2134	15	15	8
96	2438	17	17	9
120	3048	21	21	11
144	3658	25	25	13
For Other Widths, Use Odd Number of Sprockets ^c at Maximum 6 in. (152 mm) \varnothing Spacing			Maximum 6 in. (152 mm) \varnothing Spacing	Maximum 12 in. (305 mm) \varnothing Spacing

- a. If your belt width exceeds a number listed in the table, please refer to the sprocket and support material minimums for the next larger width range listed. Belts are available in 0.25 in. (6.4 mm) increments beginning with minimum width of 1.5 in. (38 mm). If the actual width is critical, consult Customer Service.
- b. These are the minimum number of sprockets. Additional sprockets may be required for heavily loaded applications.
- c. The center sprocket should be locked down. With only two sprockets, fix the sprocket on the drive journal side only. See Retainer Rings/Center Sprocket Offset chart on page 410 for lock down location.

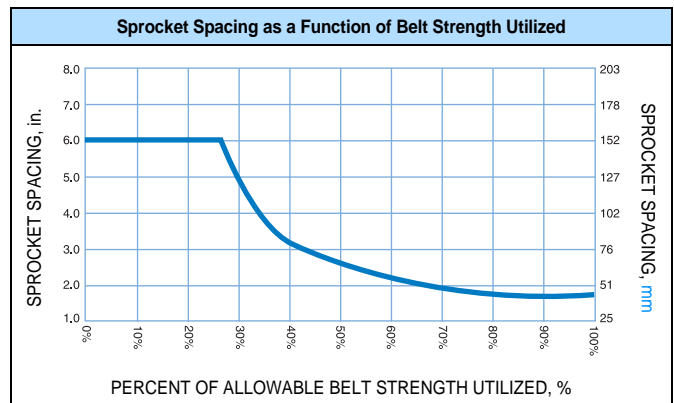
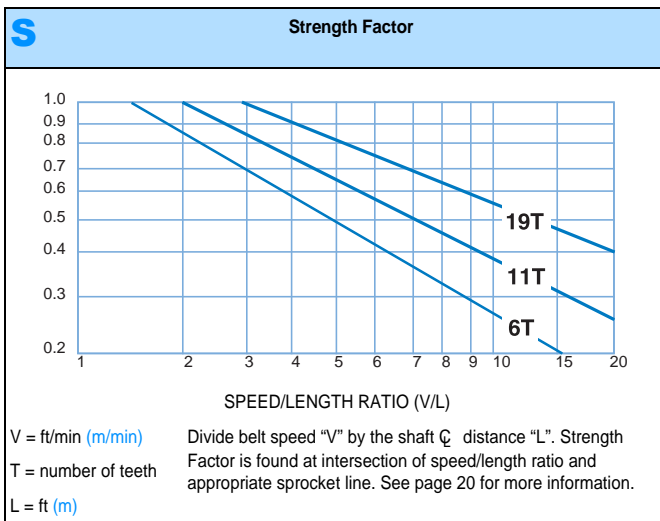

Molded Sprocket

No. of Teeth (Chordal Action)	Nom. Pitch Dia. in.	Nom. Pitch Dia. mm	Nom. Outer Dia. in.	Nom. Outer Dia. mm	Nom. Hub Width in.	Nom. Hub Width mm	Available Bore Sizes			
							U.S. Sizes		Metric Sizes	
							Round in.	Square in.	Round mm	Square mm
6 (13.40%)	2.0	51	2.1	53	0.75	19		1.0		
11 (4.05%)	3.5	89	3.7	94	0.75	19		1.0		40
								1.5		
19 (1.36%)	6.1	155	6.3	160	1.25	32		1.5		40
								2.5		60
										65

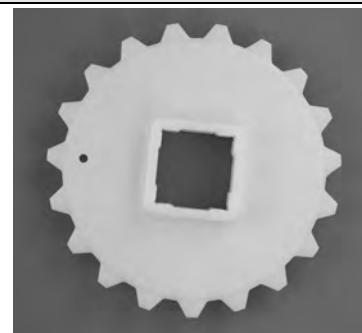

Split Metal Sprocket

No. of Teeth (Chordal Action)	Nom. Pitch Dia. in.	Nom. Pitch Dia. mm	Nom. Outer Dia. in.	Nom. Outer Dia. mm	Nom. Hub Width in.	Nom. Hub Width mm	Available Bore Sizes			
							U.S. Sizes		Metric Sizes	
							Round in.	Square in.	Round mm	Square mm
11 (4.05%)	3.5	89	3.7	94	1.5	38		1.5		40
19 (1.36%)	6.1	155	6.3	160	1.5	38		1.5		40
								2.5		60
										65



Streamline/No-Cling Flights

Available Flight Height		Available Materials
in.	mm	
1.5	38	Polypropylene, Polyethylene, Acetal

Note: Flights can be cut down to custom heights with a minimum height of 0.25 in. (13 mm).

Note: No fasteners are required.

Note: One side of the flight is smooth (Streamline) while the other is ribbed vertically (No-Cling).

Note: Flights can be provided in linear increments of 1 in. (25 mm).

Note: The minimum indent (without sideguards) is 0.5 in. (13 mm).

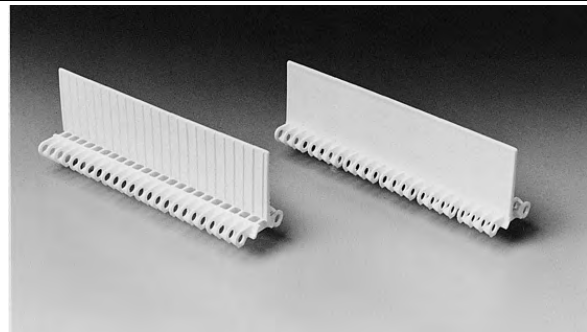

Sideguards

Available Sizes		Available Materials
in.	mm	
2	51	Polypropylene, Polyethylene, Acetal

Note: Sideguards are used with Flush Grid belts to ensure product containment, they are of the standard overlapping design, and are an integral part of the belt, fastened by the hinge rods.

Note: The minimum indent is 0.75 in. (19 mm).

Note: The standard gap between the sideguards and the edge of a flight is 0.06 in. (2 mm).

Note: When going around the 6 and 11 tooth sprockets, the sideguards fan out, opening a gap at the top of the sideguard which might allow small products to fall out. The sideguards stay completely closed when wrapping around the 19 tooth sprocket.

Note: Standard sideguard orientation is angled inward toward the product. If needed, sideguards can be angled outward toward the conveyor.



Finger Transfer Plates

Available Widths		Number of Fingers	Available Materials
in.	mm		
4	102	16	Acetal

Note: Designed to be used with Series 100 Raised Rib belts to eliminate product transfer and tipping problems.

Note: The fingers extend between the belt's ribs allowing a smooth continuation of the product flow as the belt engages its sprockets.

Note: Finger transfer plates are installed easily on the conveyor frame with conventional fasteners.

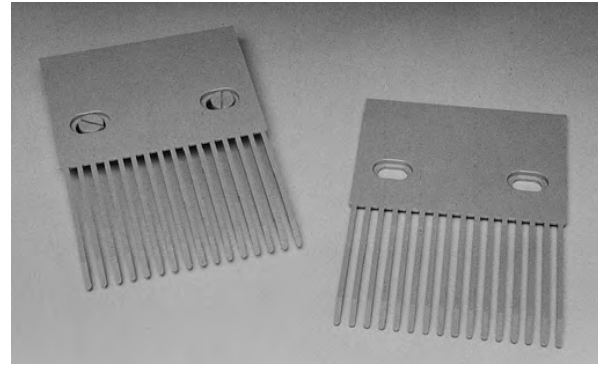

Conveyor Frame Dimensions

Regardless of type or configuration, all conveyors using Intralox belts have some basic dimensional requirements. Specifically, dimensions “A”, “B”, “C” and “E” listed below should be implemented in any design.

For general applications and applications where end transfer of tip-sensitive product is not critical, use the “A” dimension at the bottom of the range.

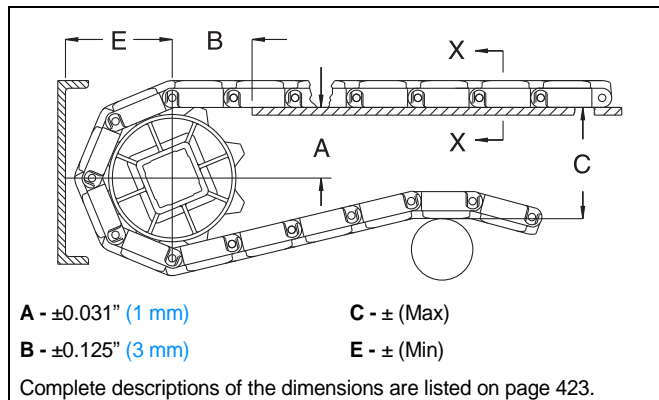

Sprocket Description			A		B		C		E	
Pitch Diameter		No. Teeth	Range (Bottom to Top)		in.	mm	in.	mm	in.	mm
in.	mm		in.	mm						
SERIES 100 FLUSH GRID										
2.0	51	6	0.69-0.83	18-21	1.30	33	2.10	53	1.24	31
3.5	89	11	1.53-1.60	39-41	1.70	43	3.60	91	2.01	51
6.1	155	19	2.82-2.87	72-73	2.20	56	6.20	157	3.30	84
SERIES 100 RAISED RIB										
2.0	51	6	0.69-0.83	18-21	1.30	33	2.10	53	1.45	37
3.5	89	11	1.53-1.60	39-41	1.70	43	3.60	91	2.23	57
6.1	155	19	2.82-2.87	72-73	2.20	56	6.20	157	3.52	89

Dead Plate Gap

Where there is a transfer point from a belt without finger transfer plates to a dead plate, there should be a gap between the surfaces to allow for the chordal action of the belt. As the belt engages its sprockets, chordal action causes the modules to move past a *fixed* point (the tip of the dead plate) with *varying* clearances. The table below shows the minimum amount of gap which occurs at the “low point” of the modules if the tip of the dead plate just comes in contact with the “high point” as the modules pass.

In some installations it may be desirable to keep the tip of the dead plate in contact with the belt, rather than allow a gap to occur. This can be done by hinging the mounting bracket for the dead plate. This allows the dead plate to move as the modules pass, but results in a small oscillating motion which may present tippage problems for sensitive containers or products.

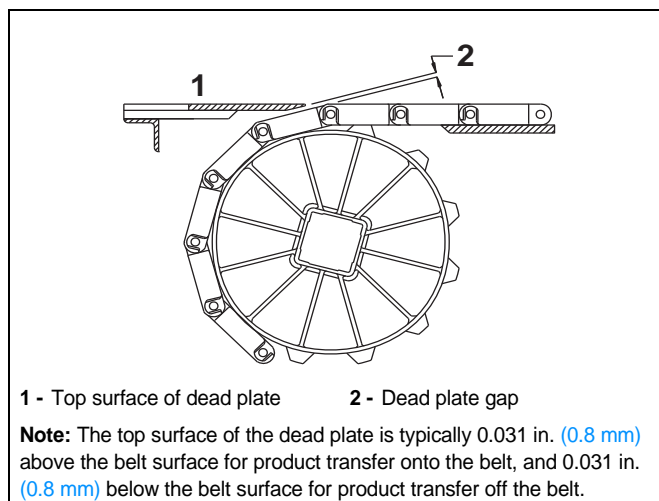

Sprocket Description			Gap	
Pitch Diameter		No. Teeth	in.	mm
in.	mm			
2.0	51	6	0.134	3.4
3.5	89	11	0.073	1.9
6.1	155	19	0.041	1.0

Open Grid		
	in	mm
Pitch	2.00	50.8
Minimum Width	2	51
Width Increments	0.36	9.1
Opening Size (approximate)	0.23 × 0.48	5.8 × 12.3
Open Area	33%	
Hinge Style	Closed	
Drive Method	Hinge-driven	
Product Notes		
<ul style="list-style-type: none"> • Contact Intralox for precise belt measurements and stock status before designing equipment or ordering a belt. • Low profile transverse ridges assist in moving products up or down inclines. • Flights and sideguards are available. • Uses headed rods. • Large, open area allows excellent drainage. • Series 200 Open Grid has double-headed hinge rods so the belt edge is not fully flush. 		
Additional Information		
<ul style="list-style-type: none"> • See “Belt Selection Process” (page 5) • See “Standard Belt Materials” (page 9) • See “Special Application Belt Materials” (page 9) • See “Friction Factors” (page 13) 		

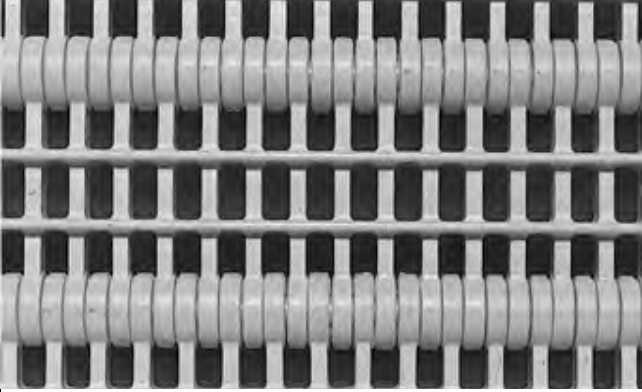
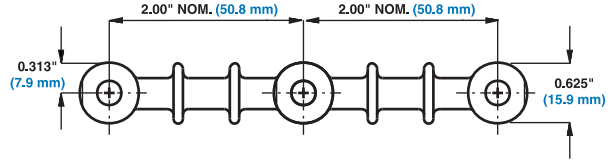
Belt Data							
Belt Material	Standard Rod Material Ø 0.240 in (6.1 mm)	BS Belt Strength		Temperature Range (continuous)		W Belt Weight	
		lb/ft	kg/m	°F	°C	lb/ft ²	kg/m ²
Polypropylene	Polypropylene	1400	2080	34 to 220	1 to 104	1.24	6.05
Polyethylene	Polyethylene	900	1340	-100 to 150	-73 to 66	1.26	6.15

Flush Grid

	in	mm
Pitch	2.00	50.8
Minimum Width	2	51
Width Increments	0.36	9.1
Opening Size (approximate)	0.22 × 0.49	5.5 × 12.5
Open Area	33%	
Hinge Style	Closed	
Drive Method	Hinge-driven	



Product Notes

- **Contact Intralox for precise belt measurements and stock status before designing equipment or ordering a belt.**
- Flush grid pattern with smooth upper surface.
- Uses headed rods.
- Offers excellent lateral movement of containers.
- One of the strongest belt styles in Series 200.
- Flights and sideguards are available.
- For an alternative to Series 200 Flush Grid with more material selections, see Series 400, Series 900, Series 1100, and Series 2200 belt styles.
- Series 200 Flush Grid has double-headed hinge rods so the belt edge is not fully flush.

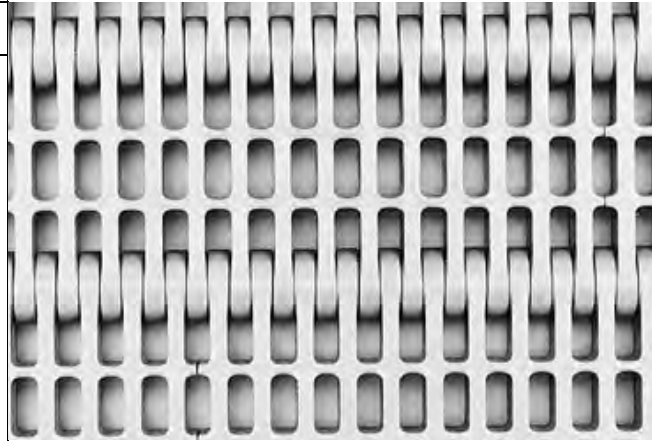

Additional Information

- See *"Belt Selection Process"* (page 5)
- See *"Standard Belt Materials"* (page 9)
- See *"Special Application Belt Materials"* (page 9)
- See *"Friction Factors"* (page 13)

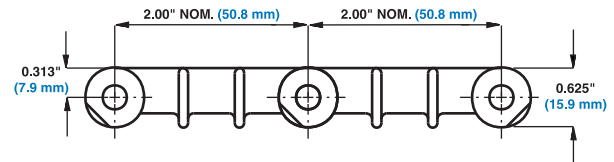

Belt Data

Belt Material	Standard Rod Material Ø 0.240 in (6.1 mm)	BS		Temperature Range (continuous)		W	
		Belt Strength		°F	°C	Belt Weight	
		lb/ft	kg/m			lb/ft ²	kg/m ²
Polypropylene	Polypropylene	1800	2680	34 to 220	1 to 104	1.40	6.83
Polyethylene	Polyethylene	1200	1790	-100 to 150	-73 to 66	1.44	7.03

Open Hinge		
	in	mm
Pitch	2.00	50.8
Minimum Width	2	51
Width Increments	0.36	9.1
Opening Size (approximate)	0.26 × 0.48	6.7 × 12.3
Open Area	45%	
Hinge Style	Open	
Drive Method	Hinge-driven	

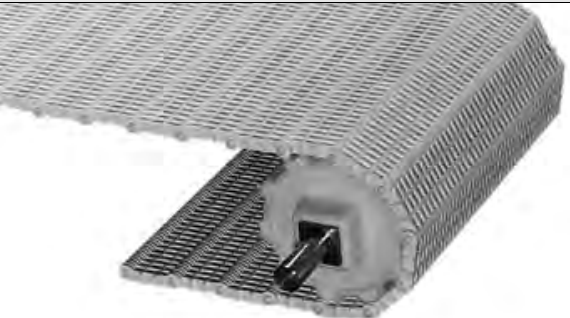

Product Notes

- Contact Intralox for precise belt measurements and stock status before designing equipment or ordering a belt.
- Smooth surface and generous open area for food handling.
- Uses headed rods.
- Ideal where air cooling, washing or drying is required.
- Flights and sideguards are available.
- For stronger belt performance, see Series 400 Open Hinge.
- Series 200 Open Hinge has double-headed hinge rods so the belt edge is not fully flush.

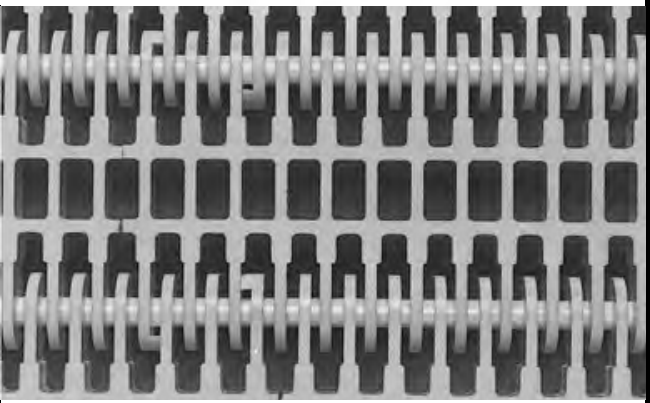

Additional Information

- See "Belt Selection Process" (page 5)
- See "Standard Belt Materials" (page 9)
- See "Special Application Belt Materials" (page 9)
- See "Friction Factors" (page 13)

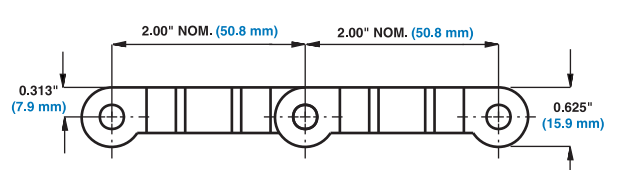

Belt Data							
Belt Material	Standard Rod Material Ø 0.240 in (6.1 mm)	BS Belt Strength		Temperature Range (continuous)		W Belt Weight	
		lb/ft	kg/m	°F	°C	lb/ft ²	kg/m ²
Polypropylene	Polypropylene	300	450	34 to 220	1 to 104	1.04	5.08
Polyethylene	Polyethylene	200	300	-50 to 150	-46 to 66	1.12	5.47

Sprocket and Support Quantity Reference				
Belt Width Range ^a		Minimum Number of Sprockets Per Shaft ^b	Wearstrips	
in.	mm		Carryway	Returnway
2	51	1	2	2
4	102	1	2	2
6	152	2	2	2
7	178	2	2	2
8	203	2	2	2
10	254	2	3	2
12	305	3	3	2
14	356	3	3	3
15	381	3	3	3
16	406	3	3	3
18	457	3	3	3
20	508	3	4	3
24	610	5	4	3
30	762	5	5	4
32	813	5	5	4
36	914	5	5	4
42	1067	7	6	5
48	1219	7	7	5
54	1372	9	7	6
60	1524	9	8	6
72	1829	11	9	7
84	2134	13	11	8
96	2438	13	12	9
120	3048	17	15	11
144	3658	21	17	13
For Other Widths, Use Odd Number of Sprockets ^c at Maximum 7.5 in. (191 mm) \varnothing Spacing			Maximum 9 in. (229 mm) \varnothing Spacing	Maximum 12 in. (305 mm) \varnothing Spacing

- a. If your belt width exceeds a number listed in the table, please refer to the sprocket and support material minimums for the next larger width range listed. Belts are available in 0.36 in. (9.1 mm) increments beginning with minimum width of 2 in. (51 mm). If the actual width is critical, consult Customer Service.
- b. These are the minimum number of sprockets. Additional sprockets may be required for heavily loaded applications.
- c. The center sprocket should be locked down. With only two sprockets, fix the sprocket on the drive journal side only. See Retainer Rings/Center Sprocket Offset chart on page 410 for lock down location.

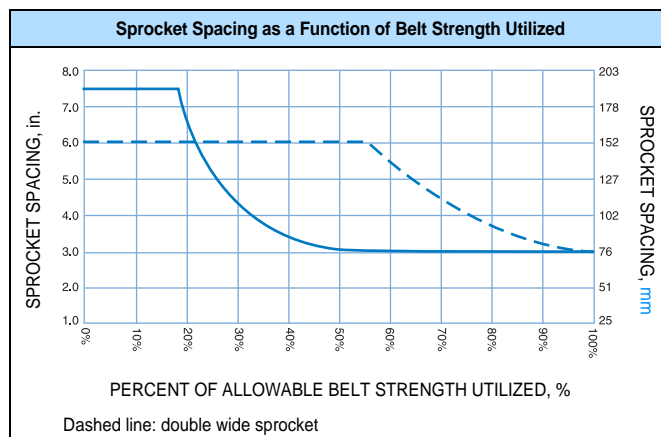
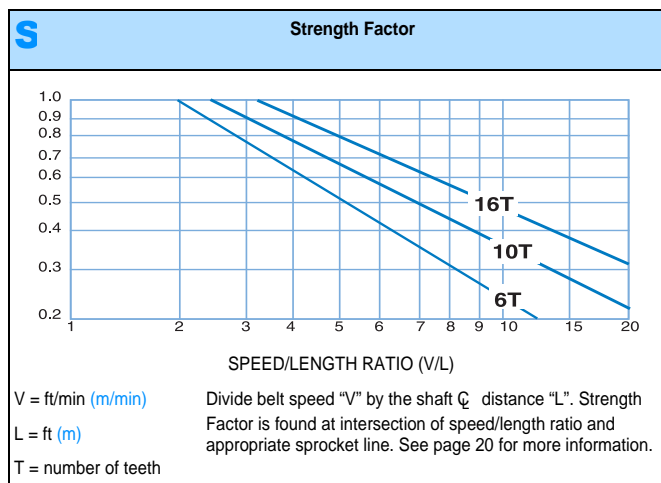

Molded Sprocket										
No. of Teeth (Chordal Action)	Nom. Pitch Dia. in	Nom. Pitch Dia. mm	Nom. Outer Dia. in	Nom. Outer Dia. mm	Nom. Hub Width in	Nom. Hub Width mm	Available Bore Sizes			
							U.S. Sizes		Metric Sizes	
							Round in	Square in	Round mm	Square mm
6 (13.40%)	4.0	102	3.9	99	1.5	38		1.5		40
10 (4.89%)	6.4	163	6.4	163	2.5	64		1.5		40
								2.5		60
16 (1.92%)	10.1	257	10.3	262	2.5	64		1.5		40
								2.5		

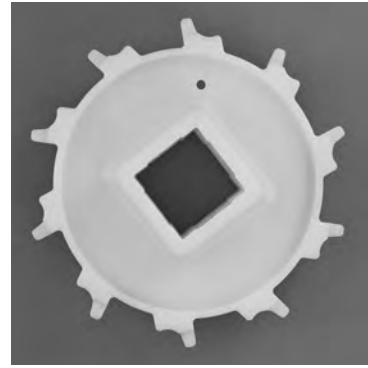

Double Wide Rim Sprocket										
No. of Teeth (Chordal Action)	Nom. Pitch Dia. in	Nom. Pitch Dia. mm	Nom. Outer Dia. in	Nom. Outer Dia. mm	Nom. Hub Width in	Nom. Hub Width mm	Available Bore Sizes			
							U.S. Sizes		Metric Sizes	
							Round in	Square in	Round mm	Square mm
10 (4.89%)	6.4	163	6.4	163	2.5	64		1.5		40

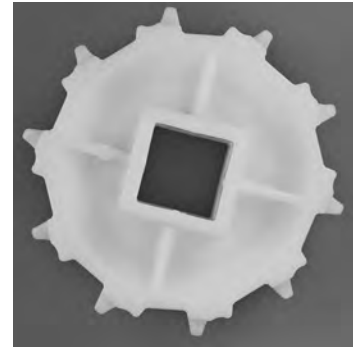

Metal Abrasion Resistant Sprocket										
No. of Teeth (Chordal Action)	Nom. Pitch Dia. in	Nom. Pitch Dia. mm	Nom. Outer Dia. in	Nom. Outer Dia. mm	Nom. Hub Width in	Nom. Hub Width mm	Available Bore Sizes			
							U.S. Sizes		Metric Sizes	
							Round in	Square in	Round mm	Square mm
10 (4.89%)	6.4	163	6.4	163	1.1	28		1.5		40
								2.5		60
16 (1.92%)	10.1	257	10.3	262	1.1	28		1.5		40
								2.5		60
										65

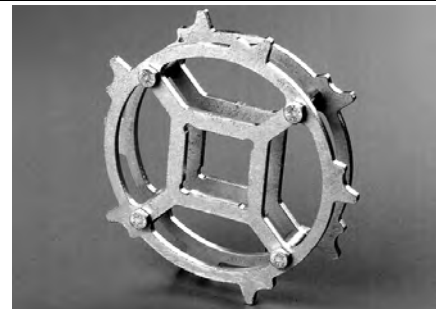

Streamline Flights

Available Flight Height		Available Materials
in	mm	
1	25	Polypropylene, Polyethylene
2	51	
3	76	

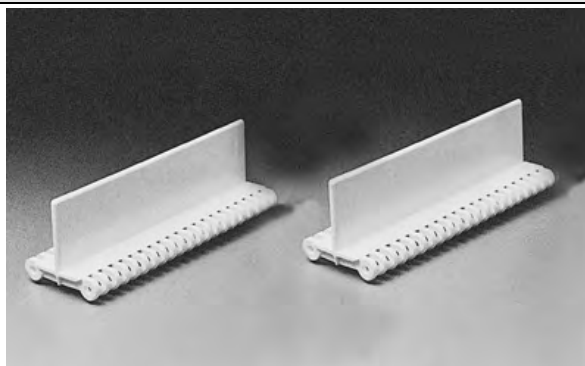

Note: Each flight rises out of the center of its supporting Flat Top module, molded as an integral part. No fasteners are required.

Note: Can be enlarged to 6 in (152 mm) high with a welded extension.

Note: An extension can be welded at a 45° angle to create a bent flight. Contact Customer Service for availability.

Note: The minimum indent (without sideguards) is 0.7 in (18 mm).

Note: Flights can be cut down to custom heights with a minimum height of 0.25 in (13 mm).

Double No-Cling Flights

Available Flight Height		Available Materials
in	mm	
3	76	Polypropylene, Polyethylene

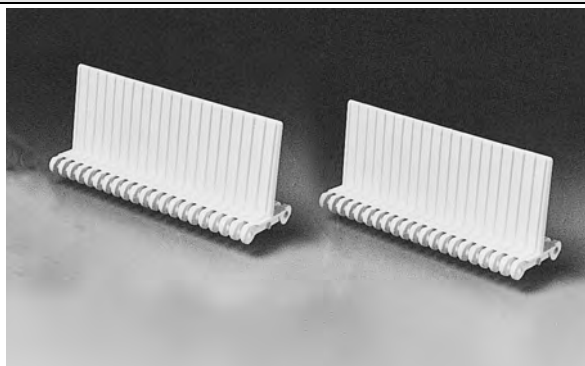

Note: Each flight rises out of the center of its supporting Flat Top module, molded as an integral part. No fasteners are required.

Note: Vertically ribbed for product release.

Note: Can be enlarged to 6 in (152 mm) high with a welded extension.

Note: An extension can be welded at a 45° angle to create a bent flight. Contact Customer Service for availability.

Note: The minimum indent (without sideguards) is 0.7 in (18 mm).

Note: Flights can be cut down to custom heights with a minimum height of 0.25 in (13 mm).

Ribbed Flights

Available Flight Height		Available Materials
in	mm	
1.25	32	Polypropylene, Polyethylene
3	76	

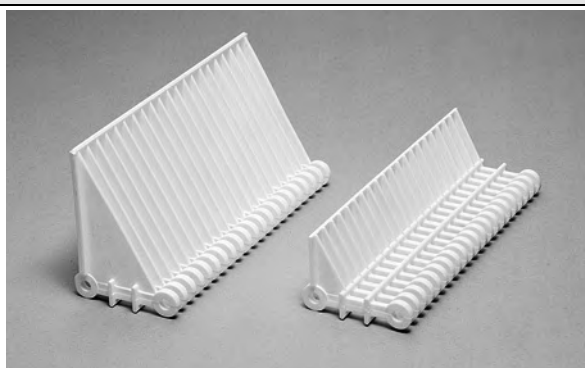

Note: Each flight rises out of Open Grid modules and has triangular shaped buttresses on the back side. No fasteners are required.

Note: Can be enlarged to 6 in (152 mm) high with a welded extension.

Note: The minimum indent (without sideguards) is 0.7 in (18 mm).

Note: Flights can be cut down to custom heights with a minimum height of 0.25 in (13 mm).

Sideguards

Available Sizes		Available Materials
in	mm	
2	51	Polypropylene, Polyethylene
3	76	
4	102	
6	152	



Note: The minimum indent is 0.7 in (18 mm).

Note: The normal gap between the sideguards and the edge of a flight is 0.3 in (8 mm).

Note: Standard sideguard orientation is angled inward toward the product. If needed, sideguards can be angled outward toward the conveyor.

Conveyor Frame Dimensions

Regardless of type or configuration, all conveyors using Intralox belts have some basic dimensional requirements. Specifically, dimensions "A", "B", "C" and "E" listed below should be implemented in any design.

For general applications and applications where end transfer of tip-sensitive product is not critical, use the "A" dimension at the bottom of the range.

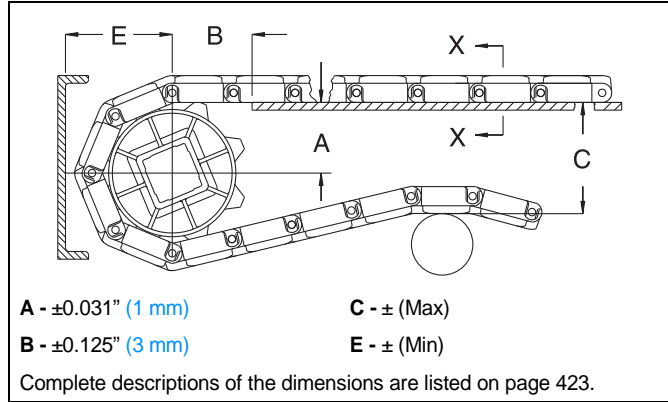

Sprocket Description		A		B		C		E		
Pitch Diameter		No. Teeth	Range (Bottom to Top)		in.	mm	in.	mm	in.	mm
in.	mm		in.	mm						
SERIES 200 FLUSH GRID, OPEN GRID, OPEN HINGE										
4.0	102	6	1.42-1.69	36-43	2.20	56	4.10	104	2.38	60
6.4	163	10	2.77-2.92	70-74	3.00	76	6.50	165	3.61	92
10.1	257	16	4.72-4.81	120-122	3.20	81	10.20	259	5.50	140

Dead Plate Gap

Where there is a transfer point from a belt without finger transfer plates to a dead plate, there should be a gap between the surfaces to allow for the chordal action of the belt. As the belt engages its sprockets, chordal action causes the modules to move past a *fixed* point (the tip of the dead plate) with *varying* clearances. The table below shows the minimum amount of gap which occurs at the "low point" of the modules if the tip of the dead plate just comes in contact with the "high point" as the modules pass.

In some installations it may be desirable to keep the tip of the dead plate in contact with the belt, rather than allow a gap to occur. This can be done by hinging the mounting bracket for the dead plate. This allows the dead plate to move as the modules pass, but results in a small oscillating motion which may present tippage problems for sensitive containers or products.

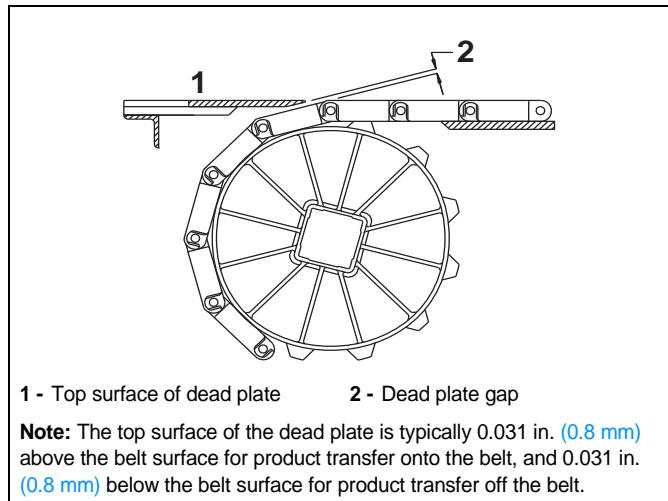

Sprocket Description			Gap	
Pitch Diameter		No. Teeth	in.	mm
in.	mm			
4.0	102	6	0.268	6.8
6.4	163	10	0.160	4.1
10.1	257	16	0.100	2.5

Flush Grid		
	in	mm
Pitch	2.00	50.8
Minimum Width	2	51
Width Increments	0.33	8.4
Opening Size (approximate)	0.25 x 0.18	6.4 x 4.6
Open Area	17%	
Hinge Style	Closed	
Drive Method	Center-driven	

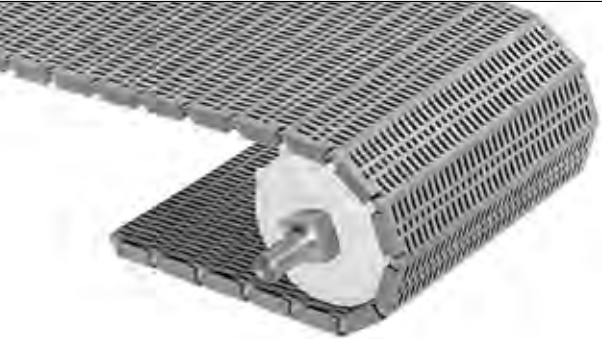

Product Notes

- **Contact Intralox for precise belt measurements and stock status before designing equipment or ordering a belt.**
- Smooth upper surface and straightforward design provides free product movement.
- Uses headed rods for belts without Slidelox® rod retention. Headless rods are used with Slidelox rod retention.
- Slidelox rod retention is recommended for belts 6.0 ft (1829 mm) wide and wider.
- Flights and Sideguards are available.

Additional Information

- See "Belt Selection Process" (page 5)
- See "Standard Belt Materials" (page 9)
- See "Special Application Belt Materials" (page 9)
- See "Friction Factors" (page 13)

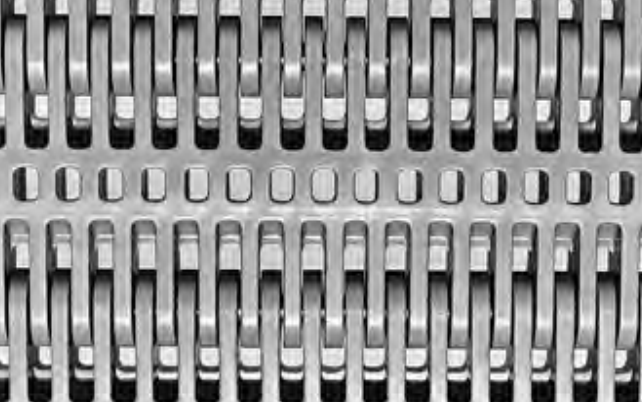
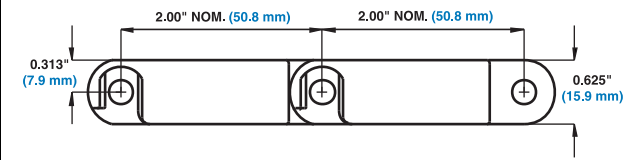



Belt Data							
Belt Material	Standard Rod Material Ø 0.24 in (6.1 mm)	BS Belt Strength		Temperature Range (continuous)		W Belt Weight	
		lb/ft	kg/m	°F	°C	lb/ft ²	kg/m ²
Polypropylene	Polypropylene	2400	3570	34 to 220	1 to 104	1.82	8.89
Polyethylene	Polyethylene	1800	2680	-100 to 150	-73 to 66	1.90	9.28
Acetal	Polypropylene	3200	4760	34 to 200	1 to 93	2.77	13.51
Acetal ^a	Polyethylene	3000	4460	-50 to 70	-46 to 21	2.77	13.51

a. Polyethylene rods can be used in cold applications when impacts or sudden starts/stops occur. Please note lower rating.

Raised Rib

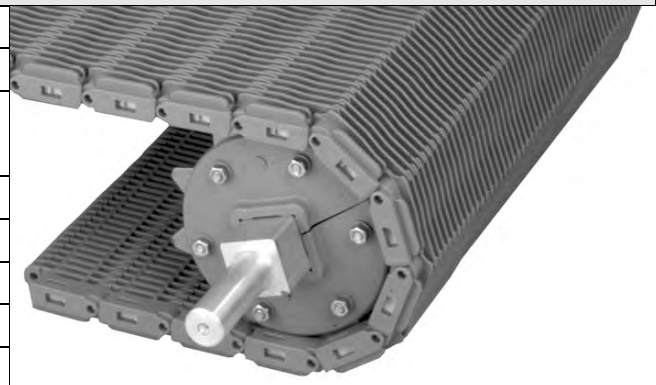
	in	mm
Pitch	2.00	50.8
Minimum Width	See below.	
Width Increments	See below.	
Opening Size (approximate)	0.25 × 0.24	6.4 × 6.1
Open Area	26%	
Product Contact Area	36%	
Hinge Style	Closed	
Drive Method	Center-driven	



Product Notes

- Contact Intralox for precise belt measurements and stock status before designing equipment or ordering a belt.
- Raised Ribs extend 0.25 in (6.4 mm) above basic module.
- Use with finger transfer plates to virtually eliminate tipping at infeed and discharge.
- Custom-built in widths from 1.8 in (47 mm) and up for polyethylene and 3.5 in (89 mm) and up for polypropylene, in 0.33 in (8.4 mm) increments.
- All S400 Raised Rib polypropylene belts use the Slidelox® rod retention system and headless rods.
- All S400 Raised Rib polyethylene belts use headed rods.
- Slidelox is glass reinforced polypropylene.
- For improved chemical resistance, Slidelox is also available in PVDF for Enduralox polypropylene belts.

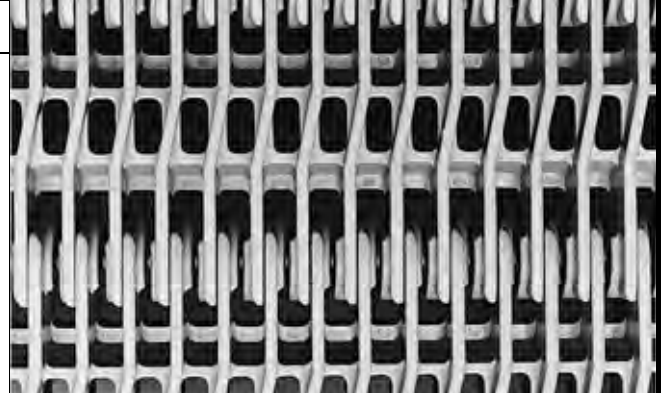

Additional Information

- See "Belt Selection Process" (page 5)
- See "Standard Belt Materials" (page 9)
- See "Special Application Belt Materials" (page 9)
- See "Friction Factors" (page 13)

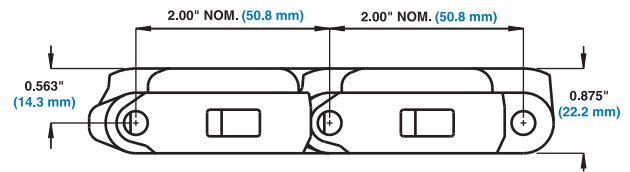

Belt Data

Belt Material	Standard Rod Material Ø 0.24 in (6.1 mm)	BS		Temperature Range (continuous)		W	
		Belt Strength	Belt Strength	°F	°C	Belt Weight	Belt Weight
		lb/ft	kg/m			lb/ft ²	kg/m ²
Polypropylene	Polypropylene	2400	3570	34 to 220	1 to 104	1.95	9.52
Polyethylene	Polyethylene	1800	2680	-100 to 150	-73 to 66	1.98	9.67
Enduralox Polypropylene	Polypropylene	2400	3570	34 to 220	1 to 104	1.95	9.52

Open Hinge		
	in	mm
Pitch	2.00	50.8
Minimum Width	2	51
Width Increments	0.25	6.4
Opening Size (approximate)	0.47 x 0.18	11.9 x 4.6
Open Area	30%	
Product Contact Area	40%	
Hinge Style	Open	
Drive Method	Center-driven	
Product Notes		
<ul style="list-style-type: none"> • Contact Intralox for precise belt measurements and stock status before designing equipment or ordering a belt. • Shares heavy-duty rating with other belts in this series. • Large, open area improves air flow, drainage, and cleanability. • Uses headed rods. • Flights and Sideguards are available. • Series 400 Open Hinge has double-headed hinge rods so the belt edge is not fully flush. 		
Additional Information		
<ul style="list-style-type: none"> • See “<i>Belt Selection Process</i>” (page 5) • See “<i>Standard Belt Materials</i>” (page 9) • See “<i>Special Application Belt Materials</i>” (page 9) • See “<i>Friction Factors</i>” (page 13) 		

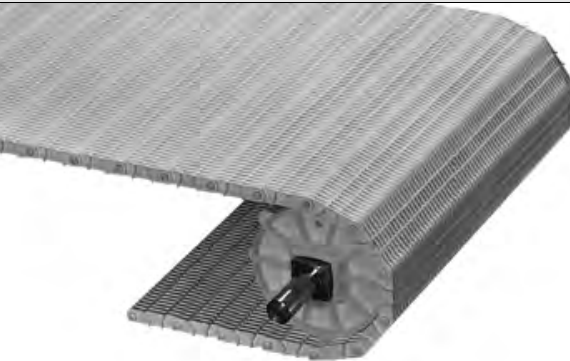
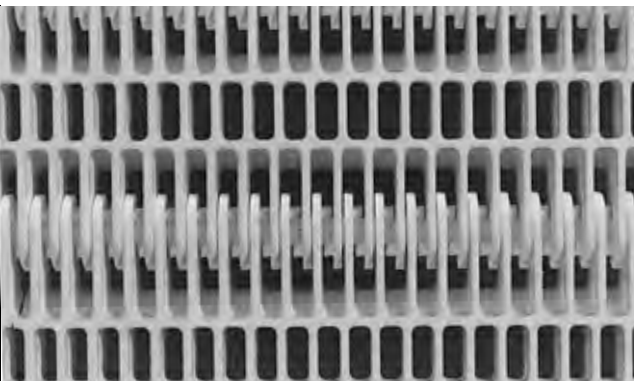
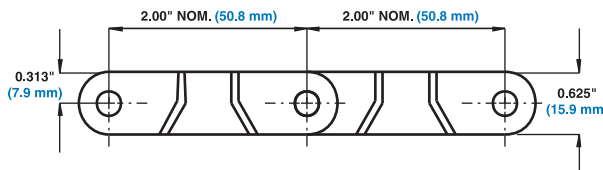
Belt Data							
Belt Material	Standard Rod Material Ø 0.24 in (6.1 mm)	BS Belt Strength		Temperature Range (continuous)		W Belt Weight	
		lb/ft	kg/m	°F	°C	lb/ft ²	kg/m ²
Polypropylene	Polypropylene	1550	2300	34 to 220	1 to 104	1.16	5.66
Polyethylene	Polyethylene	950	1400	-50 to 150	-46 to 66	1.24	6.06

Flat Top

	in	mm
Pitch	2.00	50.8
Minimum Width	2	51
Width Increments	0.33	8.4
Opening Size (approximate)	-	-
Open Area	0%	
Hinge Style	Closed	
Drive Method	Center-driven	



Product Notes

- **Contact Intralox for precise belt measurements and stock status before designing equipment or ordering a belt.**
- Smooth upper surface and straightforward design provides free product movement.
- Flights and Sideguards are available.
- It is recommended that abrasion resistant split sprockets be used with Series 400 Flat Top in acetal.
- Uses headed rods for belts without Slidelox® rod retention. Headless rods are used with Slidelox rod retention.
- Slidelox rod retention is recommended for belts 6.0 ft (1829 mm) wide and wider. All S400 Flat Top with abrasion resistant rods are available with Slidelox rod retention.

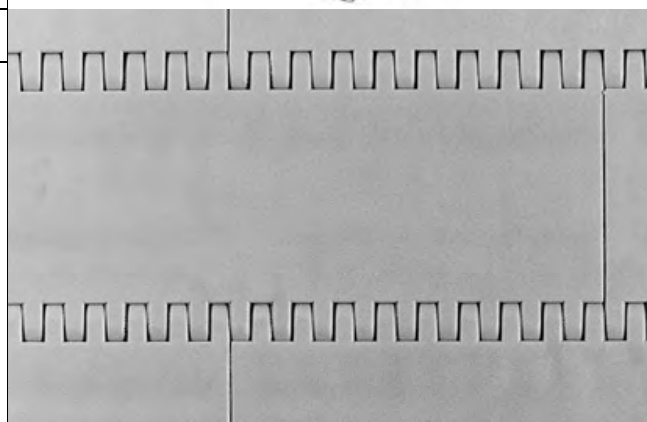

Additional Information

- See "Belt Selection Process" (page 5)
- See "Standard Belt Materials" (page 9)
- See "Special Application Belt Materials" (page 9)
- See "Friction Factors" (page 13)

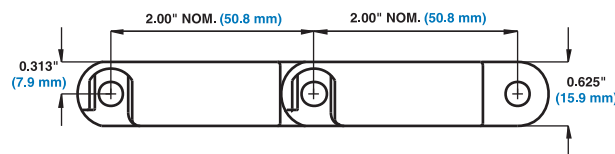

Belt Data

Belt Material	Standard Rod Material Ø 0.24 in (6.1 mm)	BS Belt Strength		Temperature Range (continuous)		W Belt Weight	
		lb/ft	kg/m	°F	°C	lb/ft ²	kg/m ²
Polypropylene	Polypropylene	2400	3570	34 to 220	1 to 104	1.81	8.82
Polyethylene	Polyethylene	1800	2680	-100 to 150	-73 to 66	1.90	9.28
Acetal	Polypropylene	3200	4760	34 to 200	1 to 93	2.74	13.38
Acetal ^a	Polyethylene	3000	4460	-50 to 70	-46 to 21	2.74	13.38

a. Polyethylene rods can be used in cold applications when impacts or sudden starts/stops occur. Please note lower rating.

Non Skid		
	in	mm
Pitch	2.00	50.8
Minimum Width	2	51
Width Increments	0.33	8.4
Opening Size (approximate)	-	-
Open Area	0%	
Hinge Style	Closed	
Drive Method	Center-driven	
Product Notes		
<ul style="list-style-type: none"> • Contact Intralox for precise belt measurements and stock status before designing equipment or ordering a belt. • Among highest strength rating of all Intralox belts. • Contact Customer Service regarding flight availability. • Uses headless rods. • All Series 400 Non Skid belts use the Slidelox® rod retention system. • Slidelox is glass reinforced polypropylene. 		
Additional Information		
<ul style="list-style-type: none"> • See “Belt Selection Process” (page 5) • See “Standard Belt Materials” (page 9) • See “Special Application Belt Materials” (page 9) • See “Friction Factors” (page 13) 		

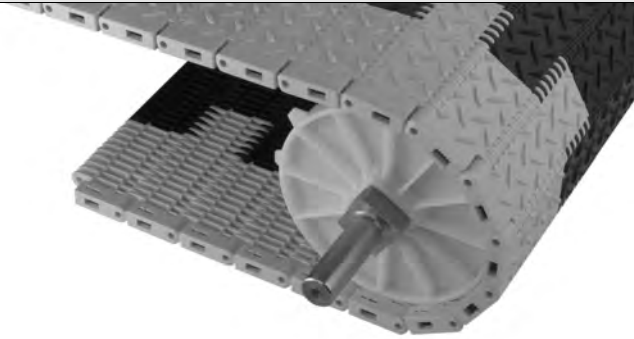
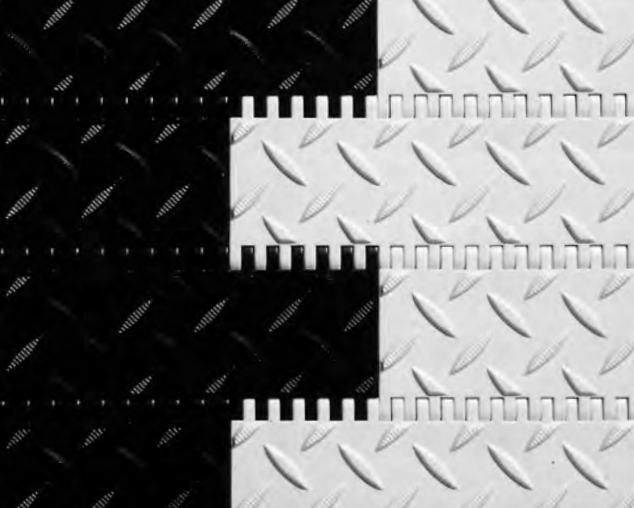
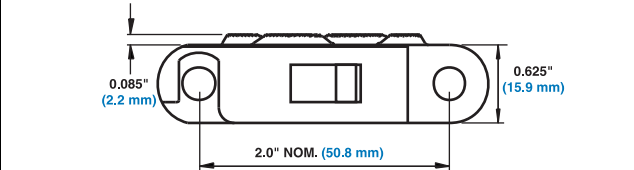
Belt Data							
Belt Material	Standard Rod Material Ø 0.24 in (6.1 mm)	BS Belt Strength		Temperature Range (continuous)		W Belt Weight	
		lb/ft	kg/m	°F	°C	lb/ft ²	kg/m ²
HSEC Acetal	Nylon	2720	4040	-50 to 200	-46 to 93	2.88	14.09
Polypropylene	Polypropylene	2400	3571	-34 to 220	1 to 104	1.81	8.84

Roller Top™		
	in	mm
Pitch	2.00	50.8
Minimum Width	6	152
Width Increments	2.00	50.8
Opening Size (approximate)	-	-
Open Area	18%	
Hinge Style	Closed	
Drive Method	Center-driven	
Product Notes		
<ul style="list-style-type: none"> • Contact Intralox for precise belt measurements and stock status before designing equipment or ordering a belt. • Slidelox® flush edges. • Acetal rollers, stainless steel axles. • Allows for low back pressure accumulation. • Uses headless rods. • Roller diameter - 0.70 in (17.8 mm). Roller length - 0.825 in (20.9 mm). • Standard roller indent is 0.90 in (23 mm) • Distance to centerline of first roller is 1.3 in (33 mm), spacing between first and second roller is 1.8 in (46 mm). Spacing between all other rollers is 2 in (50.8 mm). • Slidelox is glass reinforced polypropylene. 		
Additional Information		
<ul style="list-style-type: none"> • See "Belt Selection Process" (page 5) • See "Standard Belt Materials" (page 9) • See "Special Application Belt Materials" (page 9) • See "Friction Factors" (page 13) 		

Belt Data							
Belt Material	Standard Rod Material Ø 0.24 in (6.1 mm)	BS Belt Strength		Temperature Range (continuous)		W Belt Weight	
		lb/ft	kg/m	°F	°C	lb/ft ²	kg/m ²
Polypropylene	Nylon	2200	3270	34 to 200	1 to 93	2.44	11.94

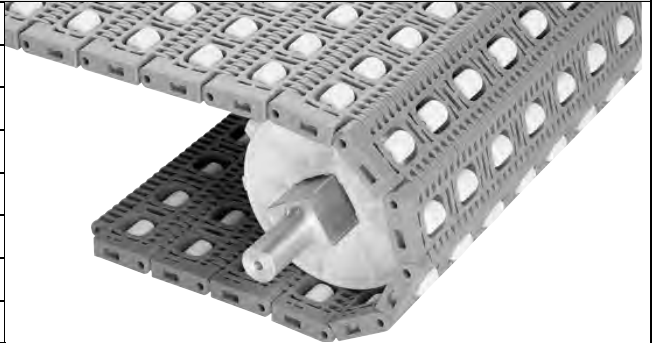
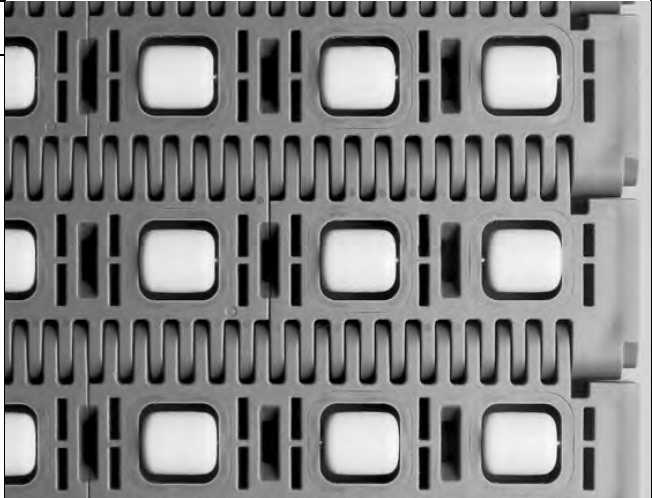
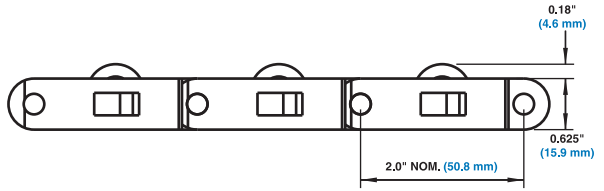
Transverse Roller Top™		
	in	mm
Pitch	2.00	50.8
Minimum Width	6	152
Width Increments	2.00	50.8
Opening Size (approximate)	-	-
Open Area	18%	
Hinge Style	Closed	
Drive Method	Center-driven	
Product Notes		
<ul style="list-style-type: none"> • Contact Intralox for precise belt measurements and stock status before designing equipment or ordering a belt. • Slidelox® flush edges. • Acetal rollers, stainless steel axles. • Designed for 90° transfers. • Roller axle pins are stainless steel for durability and long-lasting performance. • Uses headless rods. • Roller diameter - 0.70 in (17.8 mm). Roller length - 0.825 in (20.9 mm). • Standard roller indent is 0.90 in (23 mm) • 2 in (50.8 mm) roller spacing. • Slidelox is glass reinforced polypropylene. • Distance to centerline of first roller is 1.3 in (33 mm), spacing between first and second roller is 1.8 in (46 mm). Spacing between all other rollers is 2 in (50.8 mm). 		
Additional Information		
<ul style="list-style-type: none"> • See "Belt Selection Process" (page 5) • See "Standard Belt Materials" (page 9) • See "Special Application Belt Materials" (page 9) • See "Friction Factors" (page 13) 		

Belt Data							
Belt Material	Standard Rod Material Ø 0.24 in (6.1 mm)	BS	Belt Strength	Temperature Range (continuous)		W	Belt Weight
		lb/ft	kg/m	°F	°C	lb/ft ²	kg/m ²
Polypropylene	Nylon	2200	3270	34 to 200	1 to 93	2.44	11.94

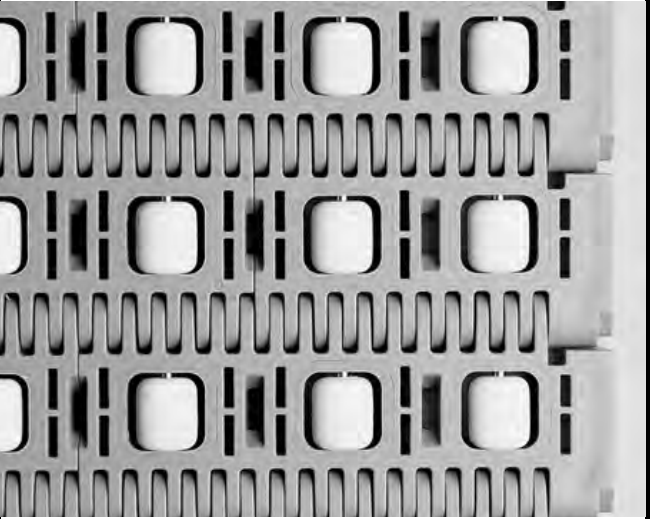
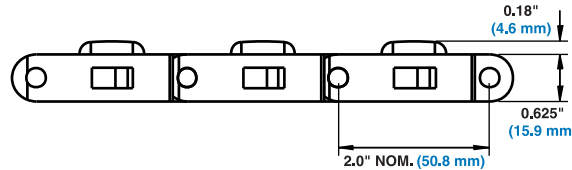
0.85 in Diameter Transverse Roller Top™

	in	mm
Pitch	2.00	50.8
Minimum Width	6	152
Width Increments	2.00	50.8
Opening Size (approximate)	-	-
Open Area	18%	
Hinge Style	Closed	
Drive Method	Center-driven	

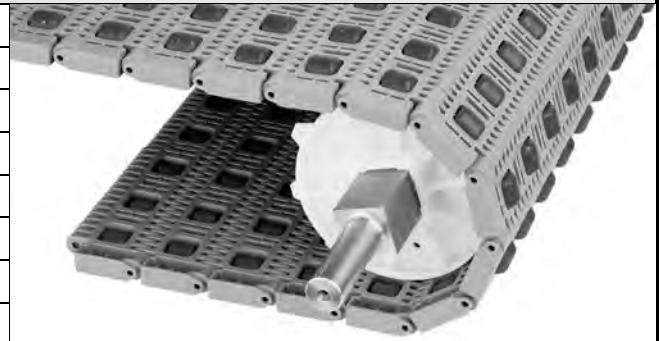

Product Notes

- **Contact Intralox for precise belt measurements and stock status before designing equipment or ordering a belt.**
- Slidelox® flush edges.
- Acetal rollers, stainless steel axles.
- Designed for 90° transfers.
- Roller axle pins are stainless steel for durability and long-lasting performance.
- Uses headless rods.
- Roller diameter - 0.85 in (21.6 mm). Roller length - 0.825 in (20.9 mm).
- Standard roller indent is 0.90 in (23 mm)
- Distance to centerline of first roller is 1.3 in (33 mm), spacing between first and second roller is 1.8 in (46 mm). Spacing between all other rollers is 2 in (50.8 mm).
- Slidelox is glass reinforced polypropylene.

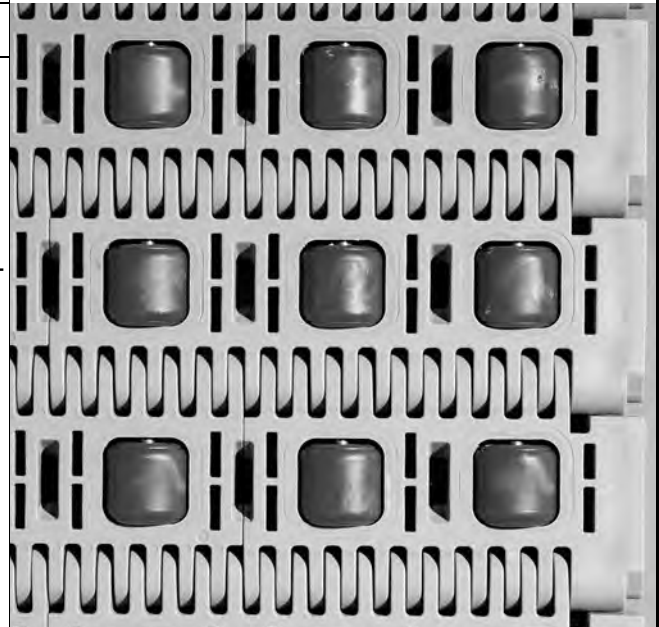

Additional Information

- See "Belt Selection Process" (page 5)
- See "Standard Belt Materials" (page 9)
- See "Special Application Belt Materials" (page 9)
- See "Friction Factors" (page 13)

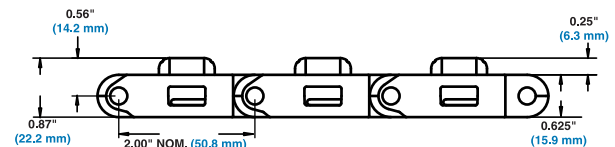

Belt Data

Belt Material	Standard Rod Material Ø 0.24 in (6.1 mm)	BS Belt Strength		Temperature Range (continuous)		W Belt Weight	
		lb/ft	kg/m	°F	°C	lb/ft ²	kg/m ²
Polypropylene	Nylon	2200	3270	34 to 200	1 to 93	2.81	13.71

0° Angled Roller™		
	in	mm
Pitch	2.00	50.8
Minimum Width	6	152
Width Increments	2.00	50.8
Opening Size (approximate)	-	-
Open Area	11%	
Hinge Style	Closed	
Drive Method	Center-driven	
Product Notes		
<ul style="list-style-type: none"> • Contact Intralox for precise belt measurements and stock status before designing equipment or ordering a belt. • This belt uses Activated Roller Belt™ technology. • Black or grey polyurethane rollers are available. All rollers have an acetal core. Axles are stainless steel. • Uses headless rods. • Rollers are in-line with the direction of belt travel. • In-line rollers can run on a standard flat continuous carryway. A chevron carryway is not recommended. • Black polyurethane rollers are not recommended for backup conditions. • 2.0 in (50.8 mm) roller spacing. • When belt rollers are in motion, product moves faster than the speed of the belt. When belt rollers do not rotate, product travels at belt speed. • Product behavior varies depending on shape and weight of product, conveyor design, and belt speed. • Intralox can help you reach a more accurate estimate of product behavior based on product and conveyor characteristics. Contact Intralox Customer Service for more information. • Custom belts consisting of any combination of 0°, 30°, 45°, or 60° are available. Custom belts can also include rollers oriented in different directions. Contact Intralox Customer Service for more information. • Angled Roller Belt will not work with the 4.0 in (102 mm) pitch diameter Split Sprocket and all 5.2 in (132 mm) pitch diameter sprockets with 2.5 in and 60 mm square bores. 		
Additional Information		
<ul style="list-style-type: none"> • See "Belt Selection Process" (page 5) • See "Standard Belt Materials" (page 9) • See "Special Application Belt Materials" (page 9) • See "Friction Factors" (page 13) 		

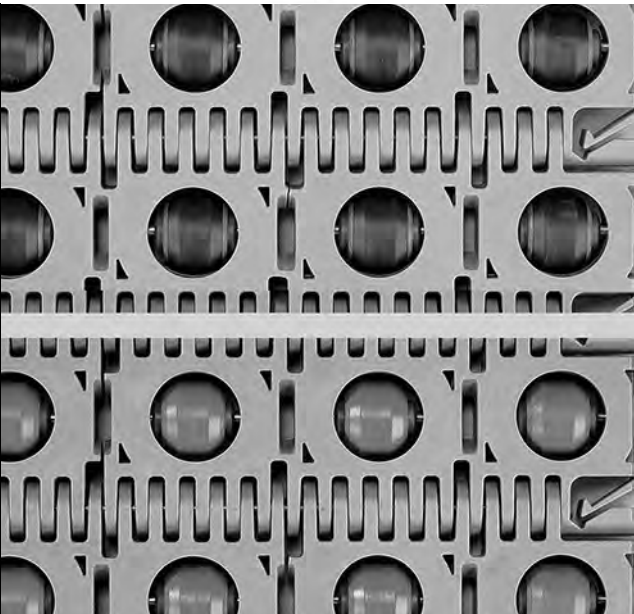
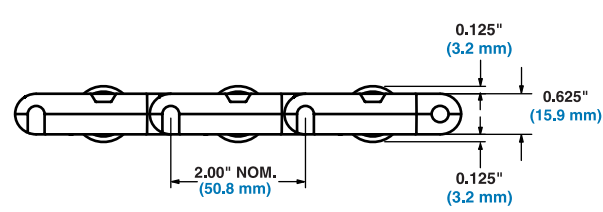
Belt Data							
Belt Material	Standard Rod Material Ø 0.24 in (6.1 mm)	BS		Temperature Range (continuous)		W	
		lb/ft	kg/m	°F	°C	lb/ft²	kg/m²
Polypropylene/Black Polyurethane	Nylon	1600	2381	34 to 200	1 to 93	2.65	12.94
Polypropylene/Grey Polyurethane	Nylon	1600	2381	34 to 120	1 to 49	2.73	13.33

30° Angled Roller™

	in	mm
Pitch	2.00	50.8
Minimum Width	6	152
Width Increments	2.00	50.8
Opening Size (approximate)	-	-
Open Area	11%	
Hinge Style	Closed	
Drive Method	Center-driven	

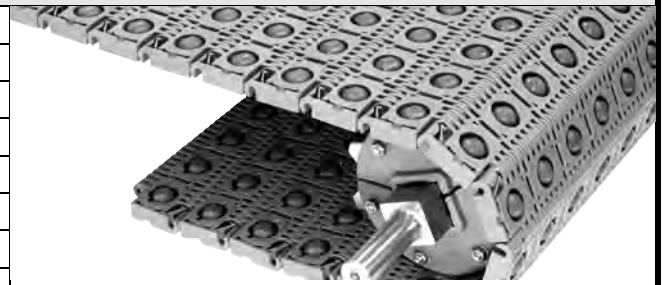

Product Notes

- **Contact Intralox for precise belt measurements and stock status before designing equipment or ordering a belt.**
- This belt uses Activated Roller Belt™ technology.
- Grey polyurethane rollers with an acetal core are available. Axles are stainless steel.
- Uses headless rods.
- Rollers are skewed 30° from the direction of belt travel.
- Grey polyurethane rollers can run on a standard flat continuous carryway. A chevron carryway is not recommended.
- Belt can be supported using parallel wearstrips placed in between belt rollers. Contact Intralox Customer Service for more information.
- 2 in (50.8 mm) roller spacing.
- When belt rollers are in motion, product moves faster than the speed of the belt. When belt rollers do not rotate, product travels at belt speed.
- Product behavior varies depending on shape and weight of product, conveyor design, and belt speed. Intralox can help you reach a more accurate estimate of product behavior based on product and conveyor characteristics. Contact Intralox Customer Service for more information.
- Centering configuration is possible using two belts with rollers oriented towards the center of the conveyor.
- Alignment belts on a flat continuous carryway require a side wearstrip and the belt should be installed to run flush along this wearstrip.
- Custom belts consisting of any combination of 0°, 30°, 45°, or 60° are available. Custom belts can also include rollers oriented in different directions. Contact Intralox Customer Service for more information.
- Angled Roller Belt will not work with the 4.0 in (102 mm) pitch diameter split sprocket and all 5.2 in (132 mm) pitch diameter sprockets with 2.5 in and 60 mm square bores.
- Minimum belt width for polyethylene is 8 in (203 mm). Polyethylene belts between 8 in (203 mm) to 10 in (254 mm) wide should be de-rated to 450 lb/ft. (670 kg/m).
- If any moisture is present, then the low temperature limit of the polyethylene belt is 34° F (1° C).
- Polyethylene belts require ultra abrasion resistant polyurethane sprocket on the drive shaft. Any sprocket can be used on the idle shaft except for sprockets with low back tension teeth.

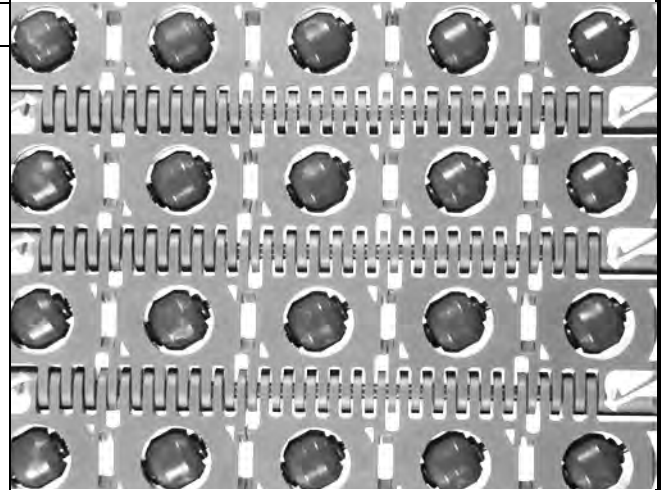

Additional Information

- See "Belt Selection Process" (page 5)
- See "Standard Belt Materials" (page 9)
- See "Special Application Belt Materials" (page 9)
- See "Friction Factors" (page 13)

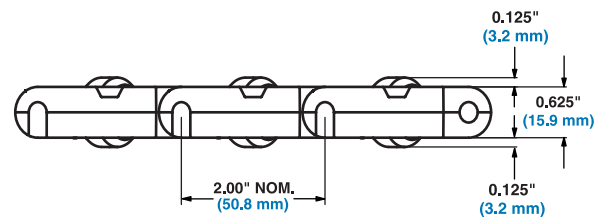

Belt Data

Belt Material	Standard Rod Material Ø 0.24 in (6.1 mm)	BS		Temperature Range (continuous)		W	
		Belt Strength	Belt Strength	°F	°C	Belt Weight	Belt Weight
		lb/ft	kg/m			lb/ft²	kg/m²
Polypropylene/Grey Polyurethane	Nylon	1600	2381	34 to 120	1 to 49	2.64	12.89
Polyethylene/Grey Polyurethane	Nylon	500	744	17 to 150	-8 to 65	2.93	14.31

90° Angled Roller™

	in	mm
Pitch	2.00	50.8
Minimum Width	6	152
Width Increments	2.00	50.8
Opening Size (approximate)	-	-
Open Area	11%	
Hinge Style	Closed	
Drive Method	Center-driven	

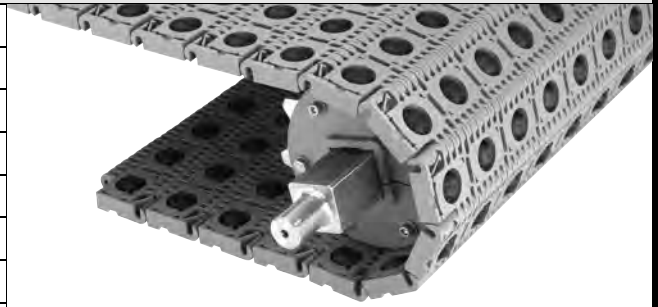

Product Notes

- **Contact Intralox for precise belt measurements and stock status before designing equipment or ordering a belt.**
- Black polyurethane rollers with an acetal core are available. Axles are stainless steel.
- Uses headless rods.
- Black polyurethane rollers should not be allowed to contact a flat continuous or chevron carryway. Belt can be supported using parallel wearstrips placed in between belt rollers. Contact Intralox Customer Service for more information.
- Black polyurethane rollers are not recommended for backup conditions.
- Roller spacing is 2.0 in (50.8 mm).
- Angled Roller belt is not compatible with the 4.0 in (102 mm) pitch diameter split sprocket and all 5.2 in (132 mm) pitch diameter sprockets with 2.5 in and 60 mm square bores.

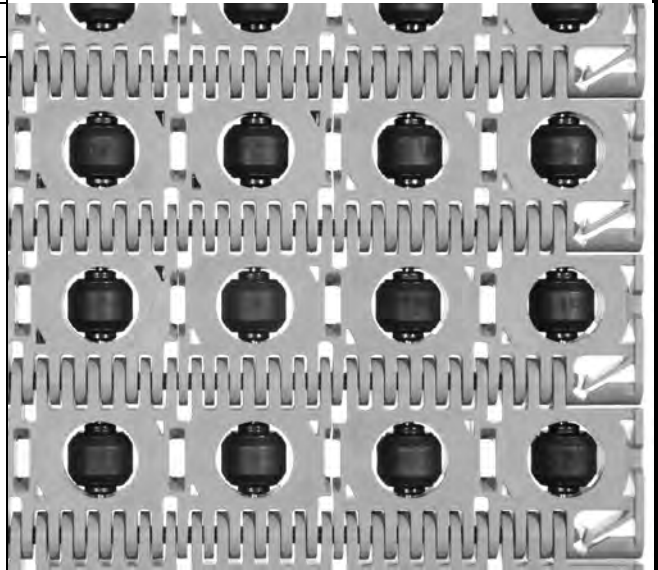

Additional Information

- See "Belt Selection Process" (page 5)
- See "Standard Belt Materials" (page 9)
- See "Special Application Belt Materials" (page 9)
- See "Friction Factors" (page 13)

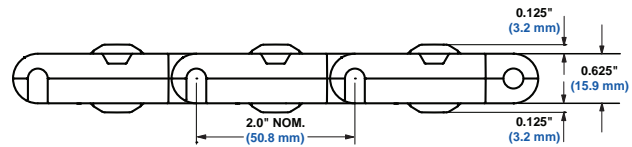

Belt Data

Belt Material	Standard Rod Material Ø 0.24 in (6.1 mm)	BS Belt Strength		Temperature Range (continuous)		W Belt Weight	
		lb/ft	kg/m	°F	°C	lb/ft ²	kg/m ²
Polypropylene/Black polyurethane	Nylon	1600	2381	34 to 200	1 to 93	2.65	12.94

0.78 in Diameter 90-Degree Angled Roller™

	in	mm
Pitch	2.0	50.8
Minimum Width	6	152.4
Width Increments	2.0	50.8
Opening Size (approximate)	-	-
Open Area	11%	
Hinge Style	Closed	
Drive Method	Center-driven	

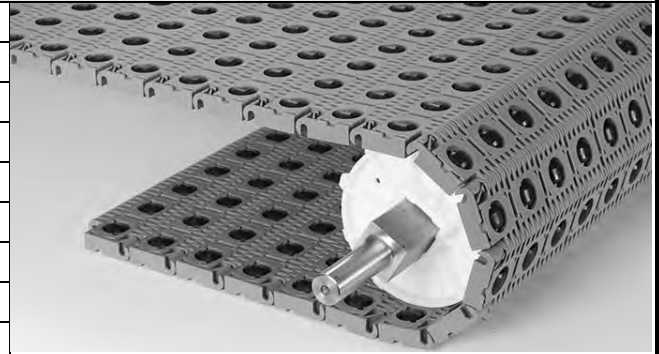

Product Notes

- Contact Intralox for precise belt measurements and stock status before designing equipment or ordering a belt.
- Black acetal rollers are available. Axles are stainless steel.
- Uses headless rods.
- Roller spacing is 2.0 in (50.8 mm).
- Angled Roller belt is not compatible with the 4.0 in (102 mm) pitch diameter split sprocket and all 5.2 in (132 mm) pitch diameter sprockets with 2.5 in and (60 mm) square bores.

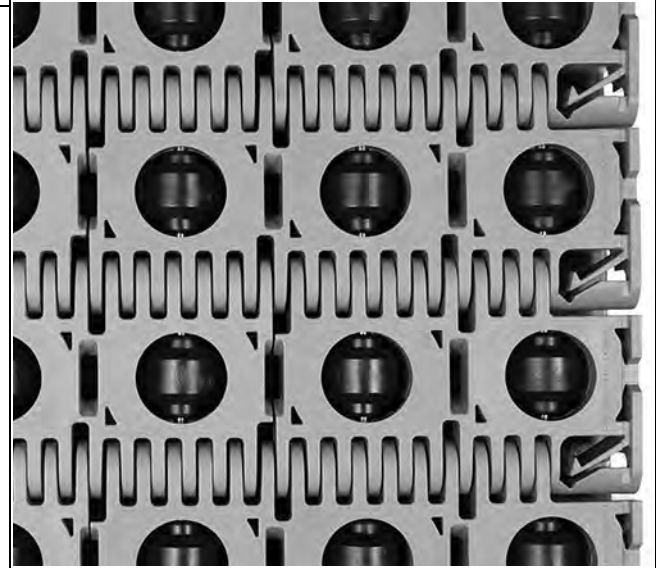

Additional Information

- See "Belt Selection Process" (page 5)
- See "Standard Belt Materials" (page 9)
- See "Special Application Belt Materials" (page 9)
- See "Friction Factors" (page 13)

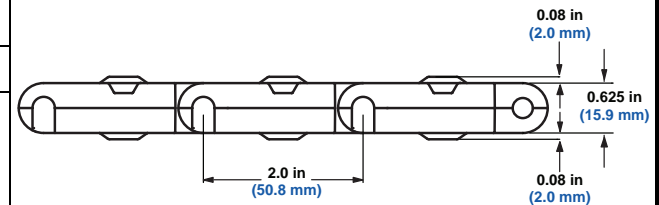

Belt Data

Belt Material	Standard Rod Material Ø 0.24 in (6.1 mm)	BS Belt Strength		Temperature Range (continuous)		W Belt Weight	
		lb/ft	kg/m	°F	°C	lb/ft²	kg/m²
Polypropylene/Black Acetal	Nylon	1600	2381	34 to 200	1 to 93	2.65	12.94

Ball Belt		
	in	mm
Pitch	2.00	50.8
Minimum Width	10	254
Width Increments	2.00	50.8
Opening Size (approximate)	-	-
Open Area	0%	
Hinge Style	Closed	
Drive Method	Center-driven	

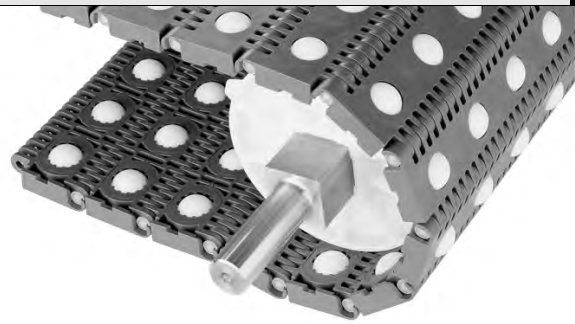

Product Notes

- **Contact Intralox for precise belt measurements and stock status before designing equipment or ordering a belt.**
- Uses headed rods.
- Acetal balls.
- Designed for applications requiring product redirection, alignment, transfer, diverting, palletizing, orientation, accumulation, or justification. Product movement is controlled by driving balls with a perpendicular secondary conveyor underneath main belt.
- Balls protrude beyond top and bottom of belt. Module does not contact carryway.
- Product on top of the balls will move faster than belt speed. Product speed will vary depending on shape and weight of product.
- Ball diameter is 1.0 in (25.4 mm)
- 2 in (50.8 mm) space between balls.
- Standard ball indent is 1.1 in (27.9 mm).
- Rod centerline to top or bottom of module is 0.313 in (7.9 mm).
- Rod centerline to top or bottom of ball is 0.50 in (12.7 mm).
- Alignment configurations should be installed to run flush along the side wearstrip.
- A flat continuous carryway is required.
- Self-set retaining rings for locking sprockets are not recommended.

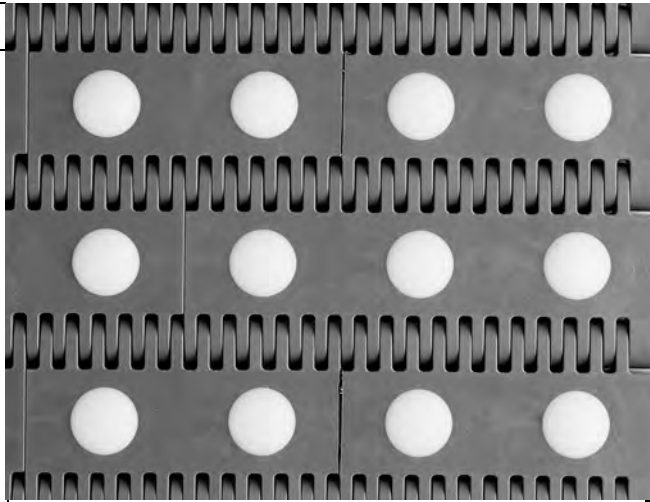

Additional Information

- See "Belt Selection Process" (page 5)
- See "Standard Belt Materials" (page 9)
- See "Special Application Belt Materials" (page 9)
- See "Friction Factors" (page 13)

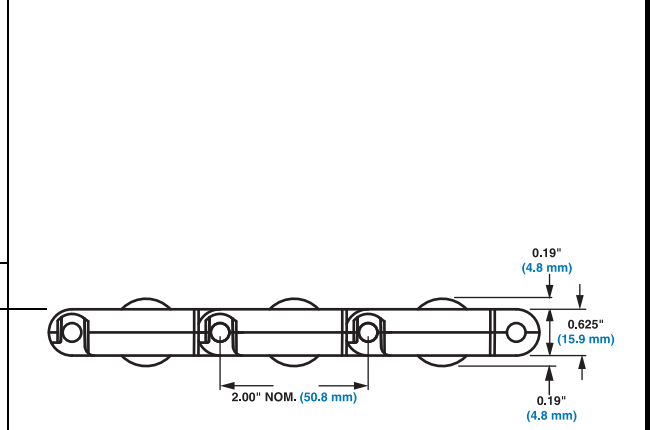

Belt Data							
Belt Material	Standard Rod Material Ø 0.24 in (6.1 mm)	BS Belt Strength ^a		Temperature Range (continuous)		W Belt Weight	
		lb/ft	kg/m	°F	°C	lb/ft ²	kg/m ²
Acetal	Polypropylene	2400	3571	34 to 200	1 to 93	3.71	18.11

a. When using steel sprockets, the belt strength for polyethylene is 240 lb/ft (360 kg/m).

Sprocket and Support Quantity Reference				
Belt Width Range ^a		Minimum Number of Sprockets Per Shaft ^b	Wearstrips	
in.	mm		Carryway	Returnway
2	51	1	2	2
4	102	1	2	2
6	152	2	2	2
7	178	2	2	2
8	203	2	2	2
10	254	2	3	2
12	305	3	3	2
14	356	3	3	3
15	381	3	3	3
16	406	3	3	3
18	457	3	3	3
20	508	5	4	3
24	610	5	4	3
30	762	5	5	4
32	813	7	5	4
36	914	7	5	4
42	1067	7	6	5
48	1219	9	7	5
54	1372	9	7	6
60	1524	11	8	6
72	1829	13	9	7
84	2134	15	11	8
96	2438	17	12	9
120	3048	21	15	11
144	3658	25	17	13
For Other Widths, Use Odd Number of Sprockets ^c at Maximum 6 in. (152 mm) \varnothing Spacing			Maximum 9 in. (229 mm) \varnothing Spacing ^d	Maximum 12 in. (305 mm) \varnothing Spacing

- a. If your belt width exceeds a number listed in the table, please refer to the sprocket and support material minimums for the next larger width range listed. Flat Top, Flush Grid, and Raised Rib belts are available in 0.33 in. (8.4 mm) increments beginning with a minimum width of 2 in. (51 mm). The increment for Open Hinge belts is 0.25 in. (6 mm). **If the actual width is critical, consult Customer Service.**
- b. These are the minimum number of sprockets. Additional sprockets may be required for heavily loaded applications.
- c. The center sprocket should be locked down. With only two sprockets, fix the sprocket on the drive journal side only. See Retainer Rings/Center Sprocket Offset chart on page 410 for lock down location.
- d. Ball Belt and some Angled Roller Belts require a flat continuous carryway.

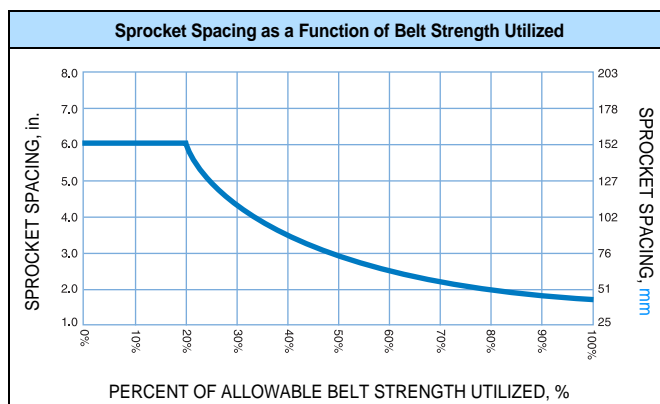
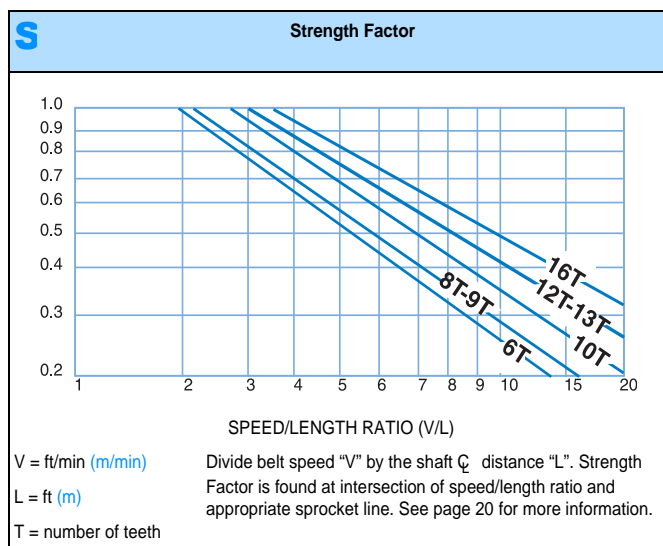

Molded Sprocket^a For all belts except Flush Grid Acetal										
No. of Teeth (Chordal Action)	Nom. Pitch Dia. in	Nom. Pitch Dia. mm	Nom. Outer Dia. in	Nom. Outer Dia. mm	Nom. Hub Width in	Nom. Hub Width mm	Available Bore Sizes			
							U.S. Sizes		Metric Sizes	
							Round in ^b	Square in	Round mm ^b	Square mm
6 (13.40%)	4.0	102	3.6	91	1.5	38	1.5		40	
8 (7.61%)	5.2	132	5.0	127	1.5	38	1.5 2.5		40 60	
10 (4.89%)	6.4	163	6.3	160	1.5	38	2.0 1.5 2.5		82 40 60	
12 (3.41%)	7.8	198	7.7	196	1.5	38	1.5 2.5		40 60	
16 (1.92%)	10.1	257	10.2	259	1.5	38	1.5 2.5 3.5		40 60 90	

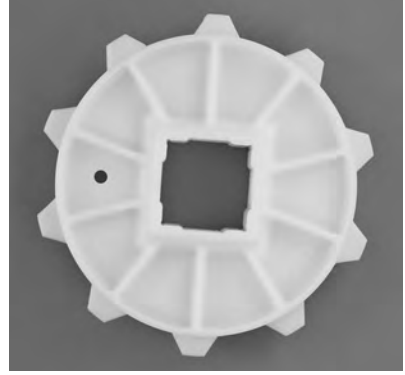

- a. Contact Customer Service for lead times.
- b. Round bore molded and split sprockets are frequently furnished with two keyways. Use of two keys is NOT REQUIRED nor recommended. Round bore sprockets do not have set screws for locking the sprockets in place. As with square bore sprockets, only the center-most sprocket needs to be locked down. Imperial key sizes on round bore sprockets conform to ANSI standard B17.1-1967(R1989) and metric key sizes conform to DIN standard 6885.

Split Low Back Tension Ultra Abrasion Resistant Polyurethane Sprocket^a For all belts except Flush Grid Acetal, Open Hinge and Roller Belts										
No. of Teeth (Chordal Action)	Nom. Pitch Dia. in	Nom. Pitch Dia. mm	Nom. Outer Dia. in	Nom. Outer Dia. mm	Nom. Hub Width in	Nom. Hub Width mm	Available Bore Sizes			
							U.S. Sizes		Metric Sizes	
							Round in	Square in	Round mm	Square mm
10 (4.89%)	6.4	163	6.3	160	1.5	38	1.5 2.5		40	
12 (3.41%)	7.8	198	7.7	196	1.5	38	2.5			
16 (1.92%)	10.1	257	10.2	259	1.5	38	2.5			

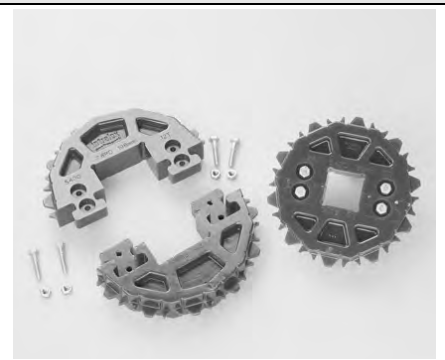

- a. **Contact Customer Service for lead times.** When using Low Back Tension Ultra Abrasion Resistant Polyurethane Split Sprockets, the maximum Belt Strength for all styles and materials is 1000 lb/ft (1490 kg/m), and the temperature range for the sprocket is -40 °F (-40 °C) to 160 °F (71 °C).

Split Ultra Abrasion Resistant Polyurethane Sprocket^a										
No. of Teeth (Chordal Action)	Nom. Pitch Dia. in	Nom. Pitch Dia. mm	Nom. Outer Dia. in	Nom. Outer Dia. mm	Nom. Hub Width in	Nom. Hub Width mm	Available Bore Sizes			
							U.S. Sizes		Metric Sizes	
							Round in	Square in	Round mm	Square mm
10 (4.89%)	6.4	163	6.3	160	1.5	38	1.5 2.5		40	



- a. **Contact Customer Service for lead times.** When using Ultra Abrasion Resistant Polyurethane Split Sprockets, the maximum Belt Strength for all styles and materials is 1000 lb/ft (1490 kg/m), and the temperature range for the sprocket is -40 °F (-40 °C) to 160 °F (71 °C).

Molded Tooth Plate Split Low Back Tension Polyurethane Composite Sprocket^a

For all belts except Open Hinge and Roller Belts

No. of Teeth (Chordal Action)	Nom. Pitch Dia. in	Nom. Pitch Dia. mm	Nom. Outer Dia. in	Nom. Outer Dia. mm	Nom. Hub Width in	Nom. Hub Width mm	Available Bore Sizes			
							U.S. Sizes		Metric Sizes	
							Round in	Square in	Round mm	Square mm
10 (4.89%)	6.4	163	6.3	160	1.70	43		1.5		40
								2.5		60
12 (3.41%)	7.8	198	7.7	196	1.5	38		1.5		40
								2.5		60
16 (1.92%)	10.1	257	10.2	259	1.5	38	3.5	1.5		
								2.5		
								3.5		90



a. **Contact Customer Service for lead times.** Recommended for Drive Shaft only. There is very little belt tension when a belt engages the idle sprockets. In some applications, the belt may not have enough tension to engage the added Low Back Tension teeth, causing the belt to disengage on the idle sprockets.

Molded Tooth Plate Split Polyurethane Composite Sprocket^a

No. of Teeth (Chordal Action)	Nom. Pitch Dia. in	Nom. Pitch Dia. mm	Nom. Outer Dia. in	Nom. Outer Dia. mm	Nom. Hub Width in	Nom. Hub Width mm	Available Bore Sizes			
							U.S. Sizes		Metric Sizes	
							Round in	Square in	Round mm	Square mm
10 (4.89%)	6.4	163	6.3	160	1.7	43		1.5		40
12 (3.41%)	7.8	198	7.7	196	1.5	38		1.5		40
16 (1.92%)	10.1	257	10.2	259	1.5	38	4.0	3.5		90



a. **Contact Customer Service for lead times.**

Split Metal with Polyurethane (FDA) Joining Plates Reduced Clearance Sprocket^a

No. of Teeth (Chordal Action)	Nom. Pitch Dia. in	Nom. Pitch Dia. mm	Nom. Outer Dia. in	Nom. Outer Dia. mm	Nom. Hub Width in	Nom. Hub Width mm	Available Bore Sizes			
							U.S. Sizes		Metric Sizes	
							Round in	Square in	Round mm	Square mm
8 (7.61%)	5.2	132	5.0	127	1.5	38		1.5		40
10 (4.89%)	6.4	163	6.3	160	1.5	38		1.5		40
								2.5		60
12 (3.41%)	7.8	198	7.7	196	1.5	38		1.5		40
								2.5		60

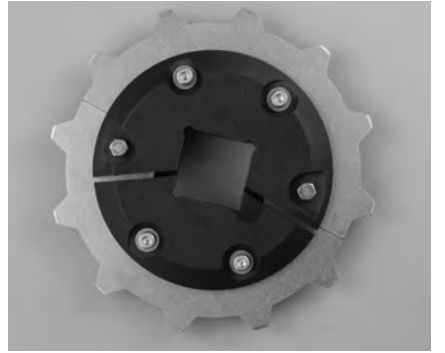

a. **Contact Customer Service for lead times.**

HR Nylon Split Sprocket^a

No. of Teeth (Chordal Action)	Nom. Pitch Dia. in	Nom. Pitch Dia. mm	Nom. Outer Dia. in	Nom. Outer Dia. mm	Nom. Hub Width in	Nom. Hub Width mm	Available Bore Sizes			
							U.S. Sizes		Metric Sizes	
							Round in	Square in	Round mm	Square mm
16 (1.92%)	10.1	257	10.2	196	2.0	51		2.5		60



a. **Contact Customer Service for lead times.** For wet applications, contact Sales Engineering.

HR Nylon Sprocket ^a										
No. of Teeth (Chordal Action)	Nom. Pitch Dia. in	Nom. Pitch Dia. mm	Nom. Outer Dia. in	Nom. Outer Dia. mm	Nom. Hub Width in	Nom. Hub Width mm	Available Bore Sizes			
							U.S. Sizes		Metric Sizes	
							Round in ^b	Square in	Round mm	Square mm
10 (4.89%)	6.4	163	6.3	160	1.5	38	1.5 2.5			
12 (3.41%)	7.8	198	7.7	196	1.5	38	1.5 2.5		40 60	
16 (1.92%)	10.1	257	10.2	259	1.5	38	1.5 2.5 3.5		60 90	



- a. **Contact Customer Service for lead times.**
 b. Imperial key sizes on round bore sprockets conform to ANSI standard B17.1-1967 (R1989) and metric key sizes conform to DIN standard 6885.

Split Metal Sprocket ^a										
No. of Teeth (Chordal Action)	Nom. Pitch Dia. in	Nom. Pitch Dia. mm	Nom. Outer Dia. in	Nom. Outer Dia. mm	Nom. Hub Width in	Nom. Hub Width mm	Available Bore Sizes			
							U.S. Sizes		Metric Sizes	
							Round in ^b	Square in	Round mm ^b	Square mm
6 (13.40%)	4.0	102	3.6	91	1.5	38		1.5		40
8 (7.61%)	5.2	132	5.0	127	1.5	38	1, 1-3/16, 1-1/4, 1-7/16	1.5	20 30 40	40 60
10 (4.89%)	6.4	163	6.3	160	1.5	38	1, 1-3/16, 1-1/4, 1-3/8, 1-7/16, 1-1/2, 1-15/16	1.5 2.5	20 40	40 60
12 (3.41%)	7.8	198	7.7	196	1.5	38	1-7/16, 1-15/16	1.5 2.5	40	40 60
16 (1.92%)	10.1	257	10.2	259	1.5	38	1-7/16, 1-15/16	1.5 2.5 3.5		40 60 90

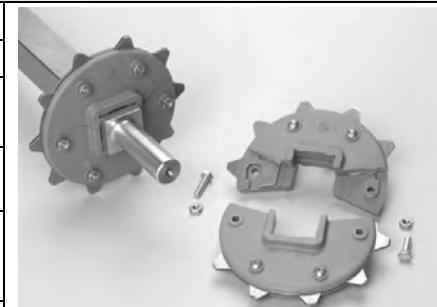

- a. **Contact Customer Service for lead times.**
 b. Round bore molded and split sprockets are frequently furnished with two keyways. Use of two keys is NOT REQUIRED nor recommended. Round bore sprockets do not have set screws for locking the sprockets in place. As with square bore sprockets, only the center-most sprocket needs to be locked down. Imperial key sizes on round bore sprockets conform to ANSI standard B17.1-1967(R1989) and metric key sizes conform to DIN standard 6885.

Split Support Wheel					
Available Pitch Dia.		Available Bore Sizes			
in	mm	U.S. Sizes		Metric Sizes	
		Round in	Square in	Round mm	Square mm
6.4	163	1	1.5 2.5		



Flush Grid Base Flights (Streamline/No-Cling)

Available Flight Height		Available Materials
in	mm	
1	25	Polypropylene, Polyethylene
2	51	
3	76	

Note: Flights can be cut down to custom heights with a minimum height of 0.25 in (13 mm).

Note: Each flight rises out of the center of its supporting module, molded as an integral part. No fasteners are required.

Note: One side of the Flush Grid flight is smooth (Streamline) while the other is ribbed vertically (No-Cling).

Note: The minimum indent (without sideguards) is 0.8 in (20 mm) and the minimum indent for a SLIDELOX® edge (without sideguards) is 1.4 in (36 mm).

Note: An extension can be welded at a 45° angle for a bent flight.

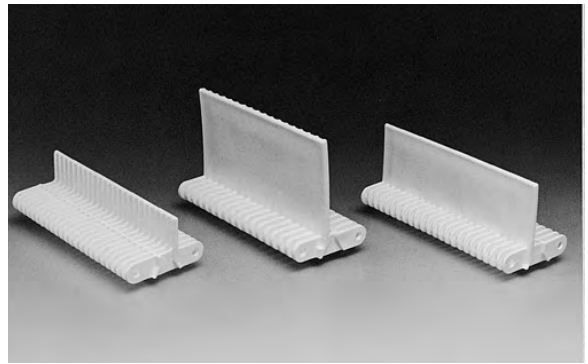

Flush Grid Base Flights (Double No-Cling)

Available Flight Height		Available Materials
in	mm	
6	152	Polypropylene, Polyethylene

Note: Flights can be cut down to custom heights with a minimum height of 0.25 in (13 mm).

Note: Each flight rises out of the center of its supporting module, molded as an integral part. No fasteners are required.

Note: The minimum indent (without sideguards) is 0.8 in (20 mm) and the minimum indent for a SLIDELOX® edge (without sideguards) is 1.4 in (36 mm).

Note: 45 degree bent flights are available in polypropylene with a 3 in (76 mm) tall base and with a 1 in (25 mm) or 2 in (51 mm) extension.

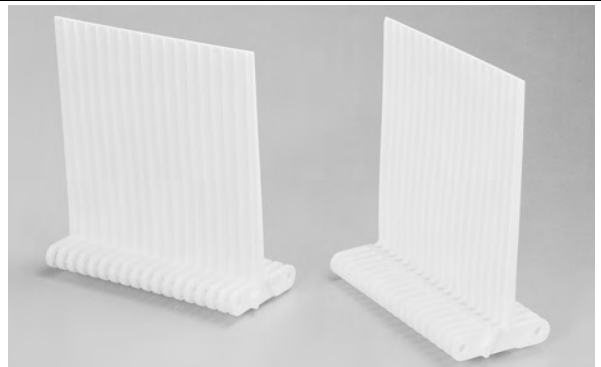

Open Hinge Base Flights (Streamline/No-Cling)

Available Flight Height		Available Materials
in	mm	
1	25	Polypropylene, Polyethylene
2	51	
3	76	

Note: Flights can be cut down to custom heights with a minimum height of 0.25 in (13 mm).

Note: Each flight rises out of the center of its supporting module, molded as an integral part. No fasteners are required.

Note: One side of the Open Hinge flight is smooth (Streamline) while the other is ribbed vertically (No-Cling).

Note: The minimum indent (without sideguards) is 0.6 in (15 mm).

Note: Series 400 Open Hinge flights can be extended to 6 in (152 mm) high (welded extension). The extension can also be welded at a 45° angle for a bent flight.

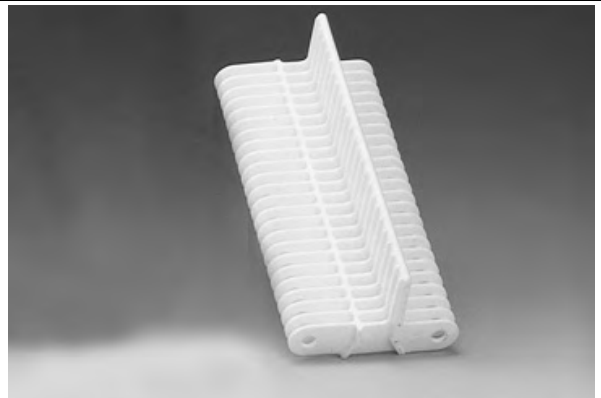

Flat Top Base Flights (Streamline)

Available Flight Height		Available Materials
in	mm	
4	102	Polypropylene, Polyethylene, Acetal
6	152	

Note: Flights can be cut down to custom heights with a minimum height of 0.25 in (13 mm).

Note: Flat Top flight is smooth (Streamline) on both sides.

Note: Each flight rises out of the center of its supporting module, molded as an integral part. No fasteners are required.

Note: The minimum indent (without sideguards) is 0.8 in (20 mm) and the minimum indent for a SLIDELOX® edge (without sideguards) is 1.4 in (36 mm).

Note: Flat Top-based flights cannot be used with Flush Grid belts.

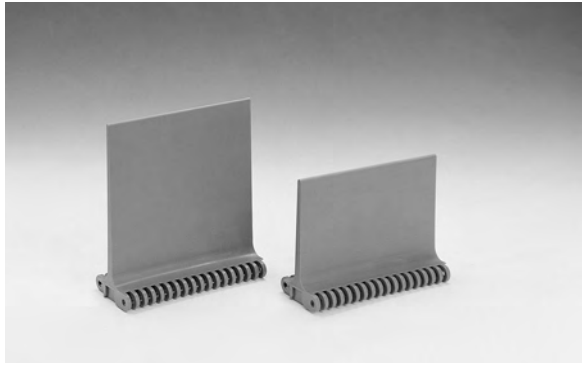

Sideguards

Available Sizes		Available Materials
in	mm	
2	51	Polypropylene, Polyethylene
3	76	
4	102	
6	152	

Note: Sideguards have a standard overlapping design and are an integral part of the belt, with no fasteners required.

Note: The minimum indent is 0.8 in (20 mm).

Note: The normal gap between the sideguards and the edge of a flight is 0.4 in (10 mm).

Note: When going around the 6 and 8 tooth sprockets, the sideguards will fan out, opening a gap at the top of the sideguard which might allow small products to fall out. The sideguards stay completely closed when going around the 10, 12 and 16 tooth sprockets.

Note: Standard sideguard orientation is angled inward toward the product. If needed, sideguards can be angled outward toward the conveyor.



Hold Down Tabs

Note: The strength rating for each hold down tab is 100 lbs (45.4 kg) of force perpendicular to the hold down surface.

Note: Tabs can be spaced along the length of the belt at either 4 inches (101.6 mm) or 6 inches (152.4 mm). Tab spacings greater than 6 inches (152.4 mm) should be avoided due to the potential of mistracking.

Note: Carryway wearstrip or rollers that engage the tabs are only required at the transition between the horizontal sections and angled sections. This reduces initial system cost, as well as ongoing maintenance cost and effort.

Note: Care should be taken to ensure that adequate lead-in radii and/or angles are used to prevent the possibility of snagging the tab on the frame.

Note: A carryway radius should be designed at the transition between horizontal sections and angled sections. This radius must be at least 48 inches (1.22 m) for belts that will be loaded near the belt's strength rating. This radius is one of the most important factors to consider when designing highly loaded conveyors that utilize hold down tabs.

Note: Available on Non Skid and Flat Top belts



Insert Nuts

Available Base Belt Style - Material		Available Insert Nut Sizes		
Series 400 Flat Top - Acetal, Polypropylene		5/16" - 18 (8 mm - 1.25 mm)		
Belt Material	Maximum Fixture Weight		Fastener Torque Specification	
	lbs/nut ^a	kg/nut ^a	in-lbs	N-m
Acetal	200	91	120	13.5
Polypropylene	175	79	65	7.3

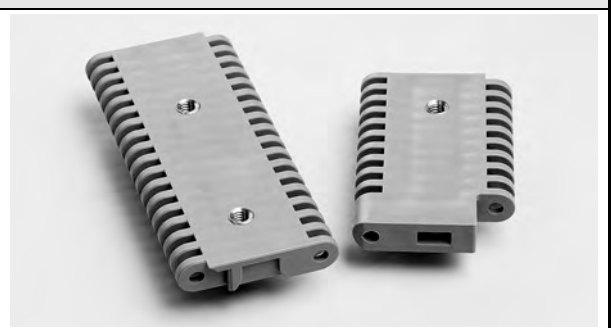

Note: Insert Nuts easily allow the attachment of fixtures to the belt.

Note: Nut placement constraints are as follows; 2" (50 mm) minimal indent from the edge of the belt, 1-1/3" (34 mm) minimal distance between nuts across the width of the belt and spacing along the length of the belt is in 2" (50 mm) increments.

Note: All nut placement dimensions are referenced from the edge of the belt when placing an order. Contact Intralox Customer Service for nut location options available for your individual belt specifications.

Note: Attachments that are connected to more than one row must not prohibit the rotation of the belt around the sprockets.

Note: Sprockets cannot be located in-line with the locations of the insert nuts in the belt.

Note: For attachment bases that extend across multiple rows, considerations should be made to accommodate for reduced backbend.

a. This is fixture weight only. Product weight need not be included.

Finger Transfer Plates

Available Widths		Number of Fingers	Available Materials
in	mm		
6	152	18	Polypropylene

Note: Eliminates product transfer and tipping problems. The 18 fingers extend between the belt's ribs allowing a smooth continuation of the product flow as the belt engages its sprockets.

Note: Easily installed on the conveyor frame with the shoulder bolts supplied. Caps snap easily into place over the bolts, keeping foreign materials out of the slots.

Note: The finger transfer plates for Series 400 are the same for Series 1200.

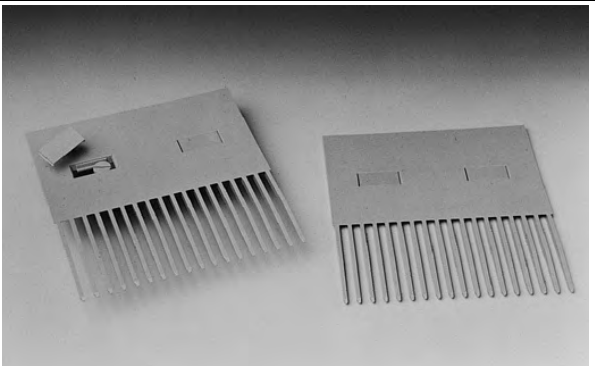

Two-Material Finger Transfer Plates

Available Widths		Number of Fingers	Available Materials
in	mm		
6	152	18	Glass-Filled Thermoplastic Fingers, Acetal Backplate

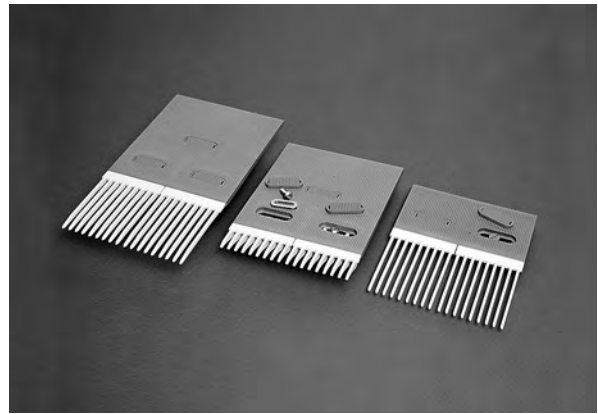

Note: Plates provide high strength fingers combined with a low friction back plate.

Note: Low-friction back plate is permanently attached to the two high-strength finger inserts.

Note: Eliminates product transfer and tipping problems. The 18 fingers extend between the belt's ribs allowing a smooth continuation of the product flow as the belt engages its sprockets.

Note: Plastic shoulder bolts and bolt covers are included for installing the standard two-material FTPs.

Note: Mounting hardware for the Glass Handling two-material FTPs is sold separately and consists of stainless steel oval washers and bolts, which give more secure fastening for the tough glass applications.

Note: The finger transfer plates for Series 400 are the same for Series 1200.

Note: Available in three different configurations:

Standard - long fingers with a short back plate.

Standard Extended Back - long fingers with an extended back plate

Glass Handling -

- Short fingers with extended back plate
- Short fingers/short back (Contact Customer Service for lead times.)
- Mid-Length Fingers/short back
- Mid-Length Fingers/extended back

The long fingers provide good support for unstable products like PET containers and cans. The short fingers are sturdy enough for even the harshest broken glass applications. These fingers are designed to resist breaking, but if confronted with deeply embedded glass, the individual fingers will yield and break off, preventing costly belt or frame damage. The short back plate has two attachment slots and the extended back plate has three attachment slots.

Note: The 10.1 in (257 mm) PD, 16 tooth sprockets are recommended to be used with the Glass Handling finger transfer plates for best product transfer.

Note: Intralox also offers a single-material polypropylene standard finger transfer plate for better chemical resistance. Mounting hardware for this FTP includes plastic shoulder bolts and snap-cap bolt covers.

Dimensional Requirements for Finger Transfer Plate Installations

	Two-Material							
	Standard Long Fingers - Short Back		Standard Long Fingers - Extended Back		Glass Handling Short Fingers - Extended Back		Glass Handling Mid Length Fingers - Extended Back	
	in	mm	in	mm	in	mm	in.	mm
F	3.50	89	3.50	89	3.50	89	3.50	89
G	0.31	8	0.31	8	0.31	8	0.31	8
H	7.2	183	10.75	273	8.26	210	9.04	230
I	5.91	150	5.91	150	5.91	150	5.91	150
J	3.00	76	3.00	76	3.00	76	3.00	76
K	1.45	37	1.45	37	1.45	37	1.45	37
L	2.00	51	5.50	140	5.50	140	5.50	140
Spacing at ambient temperature								
PP	5.952 in		151.2 mm					
PE	5.933 in		150.7 mm					

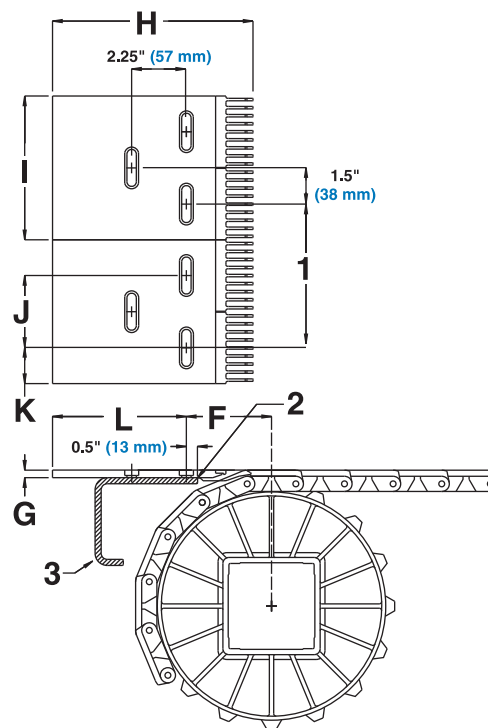

TWO-MATERIAL FINGER TRANSFER PLATES

Two-material glass handling finger transfer plate shown

- 1 - Spacing
- 2 - 0.5" (13 mm) Radius (leading edge of frame member)
- 3 - Frame member

Self-Clearing Finger Transfer Plates^a

Available Width		Number of Fingers	Available Materials
in	mm		
6	152	18	Glass-Filled Thermoplastic

Note: The self-clearing Finger Transfer System consists of a finger transfer plate and a transfer edge belt that are designed to work together. This system eliminates the need for a sweeper bar, a pusher arm, or wide transfer plates. Transfers are smooth and 100% self-clearing, making right angle transfers possible for all container types. The self-clearing Finger Transfer System is ideal for warmer/cooler applications with frequent product changeovers and is compatible with any series and style of Intralox belt on the discharge and infeed conveyors. This system is bi-directional allowing the same transfer belt to be used for both left-hand and right-hand transfers.

Note: Self-clearing Finger Transfer System is capable of transferring product to and from Intralox Series 400, Series 1200, and Series 1900 Raised Rib belts.

Note: Smooth, flat top surface provides excellent lateral movement of containers.

Note: Robust design for durability in tough glass applications.

Note: Finger transfer plates are easily installed and secured to mounting plates of any thickness with stainless steel bolts and oval washers that allow movement with the belt's expansion and contraction.

Note: Stainless steel hardware is sold separately.

Note: Self-clearing Transfer Edge Belt is molded with robust tracking tabs for belt support in heavy side-loading conditions. It has fully flush edges, headed rod retention system, and nylon rods for superior wear resistance.



a. Licensed under Rexnord U.S. Patent Nos. 7,314,130 and 7,448,490

Dimensional Requirements for Self-Clearing Finger Transfer Plate^a Installations

	Self-Clearing	
	in	mm
F	5.25	133.4
G	1.15	29.2
H	8.05	204.5
I	5.89	149.6
J	2.92	74.2
K	1.51	38.4
L	2.71	68.8
Spacing at ambient temperature		
PP	5.952 in	151.2 mm
PE	5.933 in	150.7 mm

1 - Spacing
2 - Frame Member

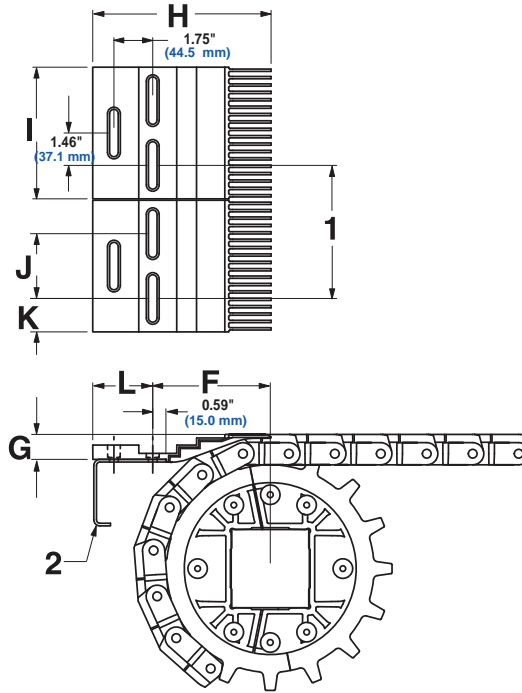

a. Licensed under Rexnord U.S. Patent Nos. 7,314,130 and 7,448,490

Conveyor Frame Dimensions

Regardless of type or configuration, all conveyors using Intralox belts have some basic dimensional requirements. Specifically, dimensions "A", "B", "C" and "E" listed below should be implemented in any design.

For general applications and applications where end transfer of tip-sensitive product is not critical, use the "A" dimension at the bottom of the range.

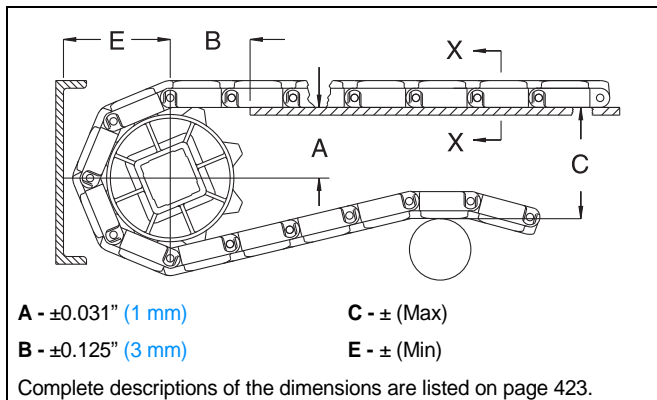

Sprocket Description		A		B		C		E		
Pitch Diameter		No. Teeth	Range (Bottom to Top)		in.	mm	in.	mm	in.	mm
in.	mm		in.	mm						
SERIES 400 FLUSH GRID, FLAT TOP, OPEN HINGE										
4.0	102	6	1.42-1.69	36-43	2.20	56	4.10	104	2.38	60
5.2	132	8	2.10-2.30	53-58	2.60	66	5.30	135	2.99	76
5.8	147	g ^a	2.44-2.61	62-66	2.70	69	5.95	151	3.49	89
6.4	163	10	2.77-2.92	70-74	2.77	70	6.50	165	3.61	92
7.8	198	12	3.42-3.55	87-90	3.00	76	7.90	201	4.24	108
8.4	213	13 ^b	3.75-3.87	95-98	3.22	82	8.46	215	4.74	120
10.1	257	16	4.72-4.81	120-122	3.20	81	10.20	259	5.50	140
SERIES 400 RAISED RIB										
4.0	102	6	1.42-1.69	36-43	2.20	56	4.10	104	2.75	70
5.2	132	8	2.10-2.30	53-58	2.60	66	5.30	135	3.24	82
6.4	163	10	2.77-2.92	70-74	2.77	70	6.50	165	3.99	101
7.8	198	12	3.42-3.55	87-90	3.00	76	7.90	201	4.49	114
10.1	257	16	4.72-4.81	120-122	3.20	81	10.20	259	5.88	149
SERIES 400 NON-SKID										
4.0	102	6	1.42-1.69	36-43	1.60	41	4.09	104	2.46	62
5.2	132	8	2.10-2.30	53-58	1.98	50	5.31	135	3.07	78
5.8	147	9	2.43-2.61	62-66	2.31	59	5.93	151	3.38	86
6.4	163	10	2.77-2.92	70-74	2.26	57	6.56	167	3.70	94
7.8	198	12	3.42-3.55	87-90	2.60	66	7.81	198	4.32	110
8.4	213	13	3.74-3.87	95-98	2.84	72	8.44	214	4.64	118
10.1	257	16	4.71-4.81	120-122	2.97	75	10.34	263	5.59	142
SERIES 400 ROLLER TOP, TRANSVERSE ROLLER TOP										
4.0	102	6	1.42-1.69	36-43	2.20	56	4.10	104	2.56	65
5.2	132	8	2.10-2.30	53-58	2.60	66	5.30	135	3.17	81
6.4	163	10	2.77-2.92	70-74	2.77	70	6.50	165	3.79	96
7.8	198	12	3.42-3.55	87-90	3.00	76	7.90	201	4.42	112
10.1	257	16	4.72-4.81	120-122	3.20	81	10.20	259	5.68	144
SERIES 400 0.85 IN. DIAMETER TRANSVERSE ROLLER TOP										
4.0	102	6	1.27-1.54	32-39	1.72	44	3.96	101	2.48	63
5.2	132	8	1.95-2.15	50-55	2.13	54	5.18	132	3.09	78

Sprocket Description		A		B		C		E		
Pitch Diameter		No. Teeth	Range (Bottom to Top)		in.	mm	in.	mm	in.	mm
in.	mm		in.	mm						
6.4	163	10	2.62-2.77	67-70	2.43	62	6.42	163	3.71	94
7.8	198	12	3.27-3.40	83-86	2.78	71	7.68	195	4.34	110
10.1	257	16	4.56-4.66	116-118	3.20	81	10.20	259	5.60	142
SERIES 400 ANGLED ROLLER (0°, 30°, 45°, 60° AND 90°)^b										
4.0	102	6	1.29-1.56	33-40	1.70	43	4.00	102	2.50	64
5.2	132	8	1.98-2.18	50-55	2.11	53	5.23	133	3.11	79
6.4	163	10	2.64-2.80	67-71	2.40	61	6.47	164	3.74	95
7.8	198	12	3.29-3.43	84-87	2.75	70	7.73	196	4.36	111
10.1	257	16	4.59-4.69	117-119	3.16	80	10.25	260	5.63	143
SERIES 400 BALL BELT^b										
4.0	102	6	1.23-1.50	31-38	1.75	44	4.00	102	2.56	65
5.2	132	8	1.91-2.11	49-54	2.16	55	5.23	133	3.18	81
6.4	163	10	2.58-2.74	65-69	2.47	63	6.47	164	3.80	96
7.8	198	12	3.23-3.36	82-85	2.82	72	7.73	196	4.43	112
10.1	257	16	4.53-4.63	115-117	3.25	82	10.25	260	5.69	144

a. Flush Grid Acetal only.

b. Dimensions are established using the top of the roller as the top of the belt and the bottom of the roller as the bottom of the belt.

Dead Plate Gap

Where there is a transfer point from a belt without finger transfer plates to a dead plate, there should be a gap between the surfaces to allow for the chordal action of the belt. As the belt engages its sprockets, chordal action causes the modules to move past a *fixed* point (the tip of the dead plate) with *varying* clearances. The table below shows the minimum amount of gap which occurs at the “low point” of the modules if the tip of the dead plate just comes in contact with the “high point” as the modules pass.

In some installations it may be desirable to keep the tip of the dead plate in contact with the belt, rather than allow a gap to occur. This can be done by hinging the mounting bracket for the dead plate. This allows the dead plate to move as the modules pass, but results in a small oscillating motion which may present tipping problems for sensitive containers or products.

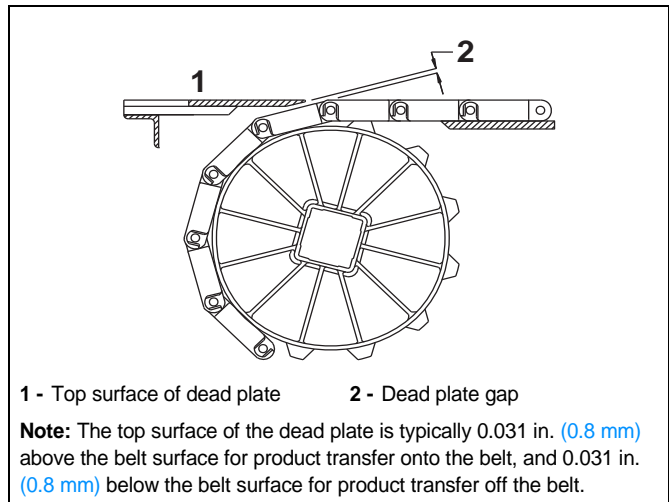

Sprocket Description			Gap	
Pitch Diameter		No. Teeth	in.	mm
in.	mm			
4.0	102	6	0.268	6.8
5.2	132	8	0.200	5.1
5.8	147	9 (Flush Grid Acetal)	0.178	4.5
6.4	163	10	0.160	4.1
7.8	198	12	0.130	3.3
8.4	213	13 (Flush Grid Acetal)	0.121	3.1
10.1	257	16	0.100	2.5

Tight Transfer Flat Top

	in	mm
Pitch	0.315	8.0
Minimum Width	8	203.2
Width Increments	1	25.4
Open Area	0%	
Hinge Style	Open	
Drive Method	Center/Hinge	

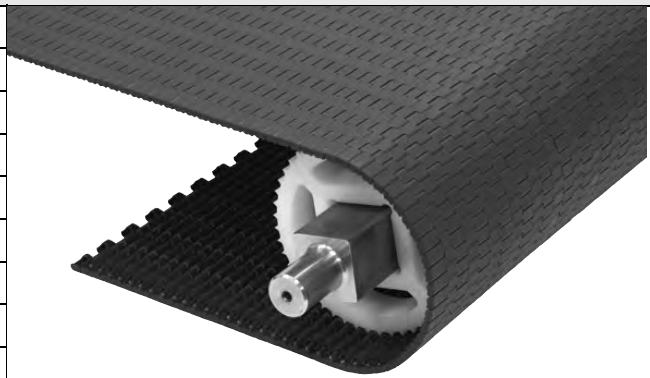

Product Notes

- **Contact Intralox for precise belt measurements and stock status before designing equipment or ordering a belt.**
- Designed for orientation-sensitive transfers.
- Conveys product over 0.25 in (6.4 mm) diameter nosebar.
- Uses headless rods.
- Reduced noise level* at higher speeds.
- Standard stainless steel retainer rings are recommended for use with 2.4 in and 3.2 in PD sprockets; corresponding heavy-duty retainer rings may also be used.
- Smooth, closed upper surface with fully flush edges and headless rods.
- Fully sculpted and radiused corners.
- Back tension required: 12 lb./ft. of belt width (17.9 kg/m).

*Compared to S1100 Flat Top in acetal and S1500 Flush Grid in acetal.

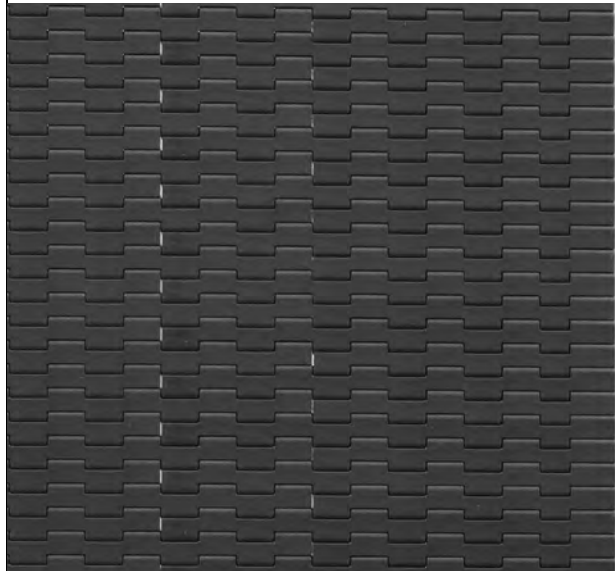

Additional Information

- See "Belt Selection Process" (page 5)
- See "Standard Belt Materials" (page 9)
- See "Special Application Belt Materials" (page 9)
- See "Friction Factors" (page 13)

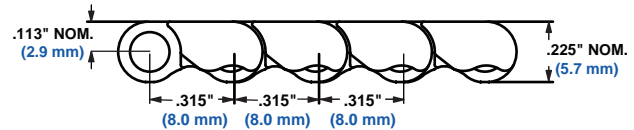

Belt Data

Base Belt Material	Standard Rod Material Ø 0.14 in (3.6 mm)	BS Belt Strength		Temperature Range (continuous)		W Belt Weight	
		lb/ft	kg/m	°F	°C	lb/ft ²	kg/m ²
Acetal	Acetal	150	220	-50 to 200	-46 to 93	1.10	5.37
HHR Nylon	Nylon	85	126	-50 to 240	-46 to 116	0.85	4.15

Sprocket and Support Quantity Reference

Belt Width Range ^a		Minimum Number of Sprockets Per Shaft ^b	Wearstrips	
in.	mm		Carryway	Returnway
8	203	3	3	3
9	229	3	3	3
10	254	4	3	3
11	279	4	4	3
12	305	4	4	3
13	330	4	4	4
14	356	4	4	4
15	381	5	4	4
16	406	5	5	4
17	432	5	5	4
18	457	5	5	4
19	483	5	5	5
20	508	6	5	5
24	610	6	6	5
30	762	8	7	6
36	914	9	9	7
42	1067	10	10	8
48	1219	11	11	9
54	1372	12	12	10
60	1524	14	13	11
66	1676	15	15	12
72	1829	16	16	13
78	1981	17	17	14
84	2134	18	18	15
90	2286	20	19	16
96	2438	21	21	17
120	3048	26	25	21
156	3962	33	33	27
For Other Widths, Use Odd Number of Sprockets ^c at 3 in. (76 mm) \varnothing Spacing			Maximum 6 in. (152 mm) \varnothing Spacing	Maximum 12 in. (305 mm) \varnothing Spacing

- If your belt width exceeds a number listed in the table, please refer to the sprocket and support material minimums for the next larger width range listed. Belts are available in 1.0 in. (25.4 mm) increments beginning with a minimum width of 8 in. (203.2 mm). **If the actual width is critical, consult Customer Service.**
- These are the minimum number of sprockets. Additional sprockets may be required for heavily loaded applications.
- The center sprocket should be locked down. With only two sprockets, fix the sprocket on the drive journal side only. See Retainer Rings/Center Sprocket Offset chart on page 410 for lock down location.

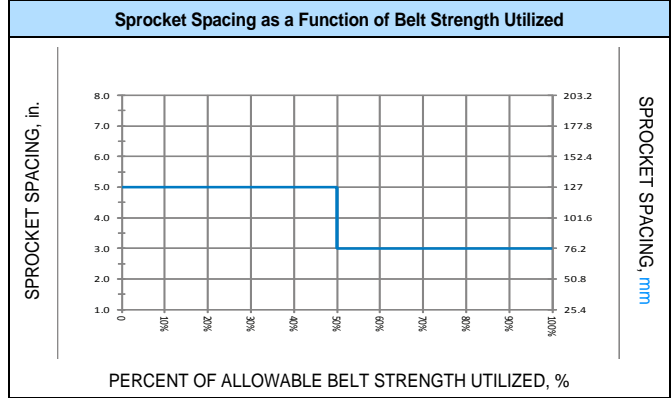
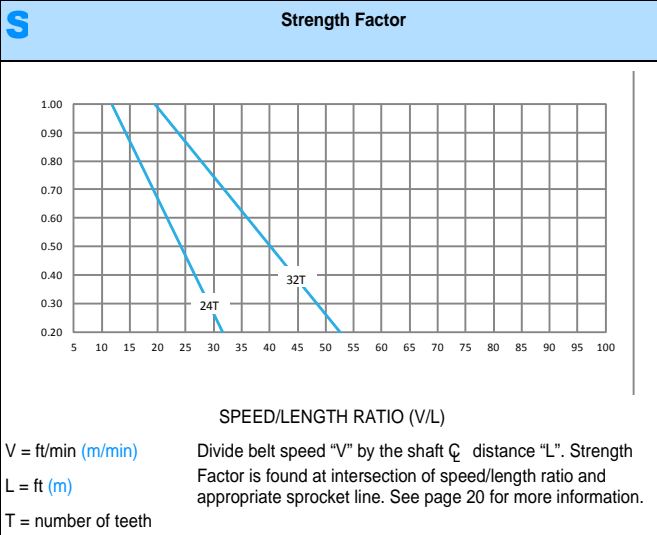

EZ Clean Sprocket

No. of Teeth (Chordal Action)	Nom. Pitch Dia. in.	Nom. Pitch Dia. mm	Nom. Outer Dia. in.	Nom. Outer Dia. mm	Nom. Hub Width in.	Nom. Hub Width mm	Available Bore Sizes			
							U.S. Sizes		Metric Sizes	
							Round in. ^a	Square in.	Round mm	Square mm
24 (0.86%)	2.4	61	2.4	61	1	25	1	1	25	
32 (0.48%)	3.2	81	3.2	81	1	25		1.5		40



a. Round bore molded and split sprockets are frequently furnished with two keyways. Use of two keys is NOT REQUIRED nor recommended. Round bore sprockets do not have set screws for locking the sprockets in place. As with square bore sprockets, only the center-most sprocket needs to be locked down. Imperial key sizes on round bore sprockets conform to ANSI standard B17.1-1967(R1989) and metric key sizes conform to DIN standard 6885.

Non-Tracking Sprocket

No. of Teeth (Chordal Action)	Nom. Pitch Dia. in.	Nom. Pitch Dia. mm	Nom. Outer Dia. in.	Nom. Outer Dia. mm	Nom. Hub Width in.	Nom. Hub Width mm	Available Bore Sizes			
							U.S. Sizes		Metric Sizes	
							Round in.	Square in.	Round mm	Square mm
24 (0.86%)	2.4	61	2.4	61	1.48	38	1	1	25	
32 (0.48%)	3.2	81	3.2	81	1.48	38		1.5		40

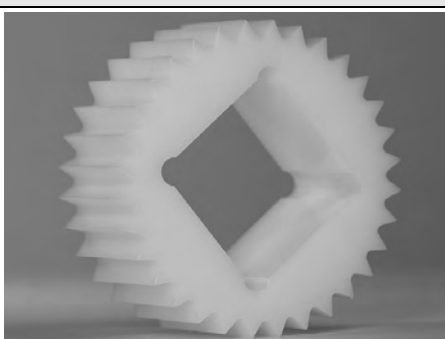

Conveyor Frame Dimensions

Regardless of type or configuration, all conveyors using Intralox belts have some basic dimensional requirements. Specifically, dimensions “A”, “B”, “C” and “E” listed below should be implemented in any design.

For general applications and applications where end transfer of tip-sensitive product is not critical, use the “A” dimension at the bottom of the range.

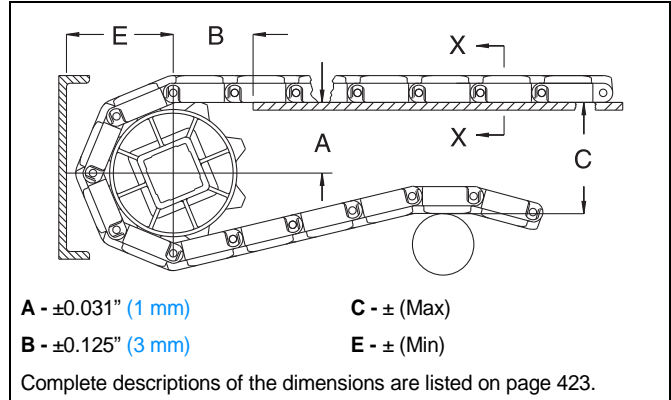

Sprocket Description			A		B		C		E	
Pitch Diameter		No. Teeth	Range (Bottom to Top)		in.	mm	in.	mm	in.	mm
in.	mm		in.	mm						
SERIES 550 TIGHT TRANSFER FLAT TOP										
2.4	61	24	1.09	28	1.27	32	2.41	61	1.38	35
3.2	81	32	1.49	38	1.51	38	3.21	82	1.78	45

Dead Plate Gap

Where there is a transfer point from a belt without finger transfer plates to a dead plate, there should be a gap between the surfaces to allow for the chordal action of the belt. As the belt engages its sprockets, chordal action causes the modules to move past a *fixed* point (the tip of the dead plate) with *varying* clearances. The table below shows the minimum amount of gap which occurs at the “low point” of the modules if the tip of the dead plate just comes in contact with the “high point” as the modules pass.

In some installations it may be desirable to keep the tip of the dead plate in contact with the belt, rather than allow a gap to occur. This can be done by hinging the mounting bracket for the dead plate. This allows the dead plate to move as the modules pass, but results in a small oscillating motion which may present tippage problems for sensitive containers or products.

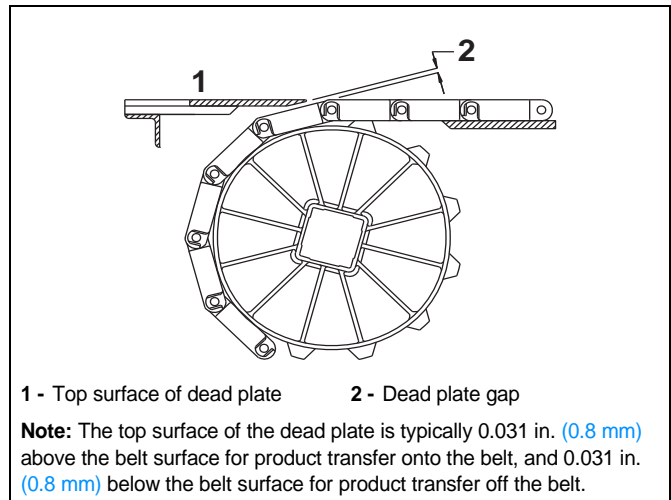

Sprocket Description			Gap	
Pitch Diameter		No. Teeth	in.	mm
in.	mm			
2.4	61	24	0.028	0.7
3.2	81	32	0.021	0.5

Flat Top		
	in	mm
Pitch	2.00	50.8
Minimum Width	2	51
Width Increments	0.66	16.8
Opening Size (approximate)	-	-
Open Area	0%	
Hinge Style	Open	
Drive Method	Center-driven	

Product Notes

- **Contact Intralox for precise belt measurements and stock status before designing equipment or ordering a belt.**
- Smooth, closed upper surface with fully flush edges.
- Uses headed rods.
- Impact resistant belt designed for tough Meat Industry applications.
- Flights and sideguards are available.

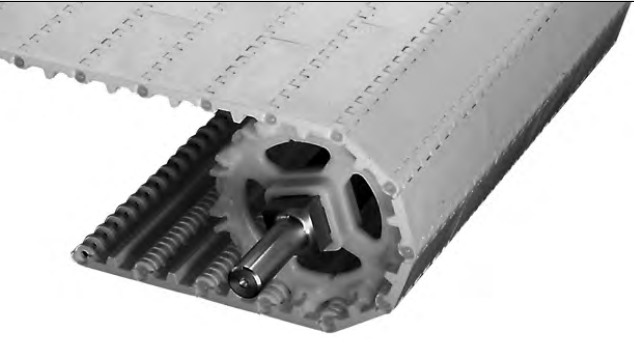
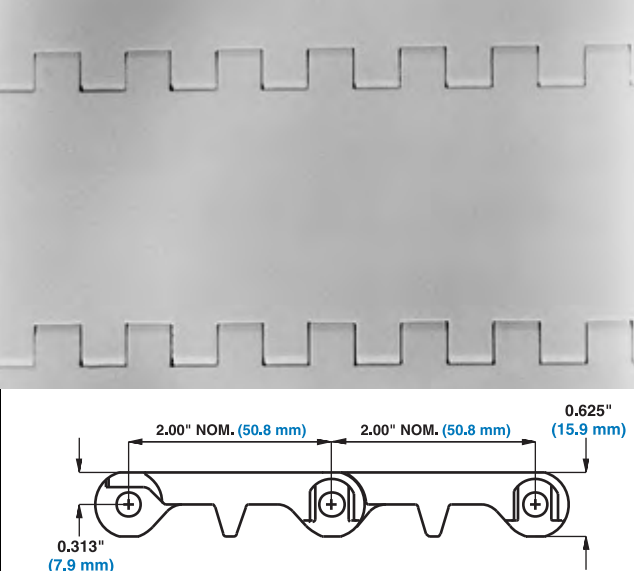
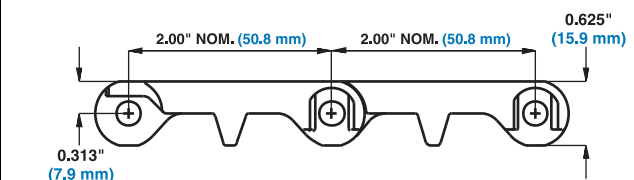



Additional Information		
<ul style="list-style-type: none"> • See “Belt Selection Process” (page 5) • See “Standard Belt Materials” (page 9) • See “Special Application Belt Materials” (page 9) • See “Friction Factors” (page 13) 		

Belt Data							
Belt Material	Standard Rod Material Ø 0.24 in (6.1 mm)	BS Belt Strength		Temperature Range (continuous)		W Belt Weight	
		lb/ft	kg/m	°F	°C	lb/ft ²	kg/m ²
Polypropylene	Polypropylene	1000	1490	34 to 220	1 to 104	1.77	8.66
Detectable Polypropylene	Polyethylene	650	967	0 to 150	-18 to 66	1.83	8.93
Polyethylene	Polyethylene	500	750	-50 to 150	-46 to 66	1.87	9.13
Acetal	Polyethylene	900	1340	-50 to 150	-46 to 66	2.75	13.43
Nylon	Polyethylene	1200	1780	-50 to 150	-46 to 66	2.32	11.33

Open Hinge Flat Top

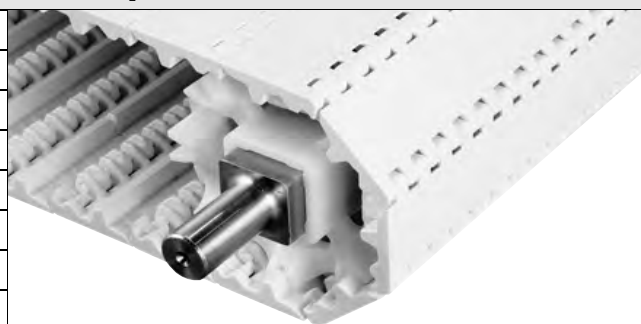
	in	mm
Pitch	2.00	50.8
Minimum Width	6	152
Width Increments	0.66	16.8
Opening Size (approximate)	-	-
Open Area	0%	
Hinge Style	Open	
Drive Method	Center-driven	



Product Notes

- **Contact Intralox for precise belt measurements and stock status before designing equipment or ordering a belt.**
- Smooth, closed upper surface with fully flush edges.
- Uses headed rods.
- Cam-link designed hinges - expose more hinge and rod area as the belt goes around the sprocket. This exclusive Intralox feature allows unsurpassed cleaning access to this area.
- Fully sculpted and radiused corners - no pockets or sharp corners to catch and hold debris.
- Like Series 1600 and Series 1800, the drive bar on the underside of Series 800 Open Hinge Flat Top channels water and debris to the outside of the belt for easier, faster cleanup. The drive bar's effectiveness has been proven both in-house and in field tests.
- Fully compatible with industry-proven Series 800 Flat Top – can be spliced directly into Series 800 Flat Top, using the same sprockets and accessories.
- Streamlined flights are available. Standard height is 6 in (152.4 mm) or they can be cut down to custom heights.

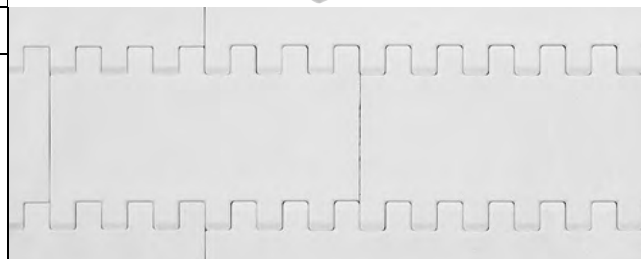

Top Side

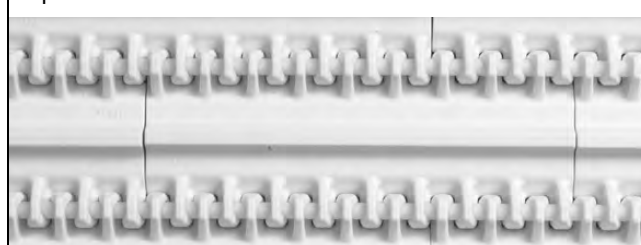

Under Side

Additional Information

- See "Belt Selection Process" (page 5)
- See "Standard Belt Materials" (page 9)
- See "Special Application Belt Materials" (page 9)
- See "Friction Factors" (page 13)

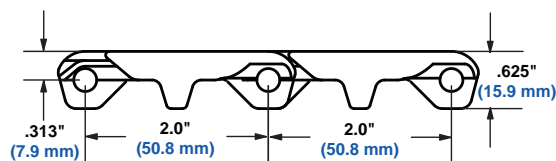

Belt Data							
Belt Material	Standard Rod Material Ø 0.24 in (6.1 mm)	BS Belt Strength		Temperature Range (continuous)		W Belt Weight	
		lb/ft	kg/m	°F	°C	lb/ft ²	kg/m ²
Polypropylene	Polypropylene	900	1340	34 to 220	1 to 104	1.63	7.96
Polyethylene	Polyethylene	500	750	-50 to 150	-46 to 66	1.70	8.30
Acetal	Polyethylene	900	1340	-50 to 150	-46 to 66	2.52	12.3
Detectable Polypropylene ^a	Blue Polyethylene	500	750	0 to 150	-18 to 66	1.83	8.93

a. Detectable Polypropylene can be sensed with metal detection equipment. Testing the material on a metal detector in a production environment is the best method for determining detection sensitivity.

SeamFree™ Open Hinge Flat Top		
	in	mm
Pitch	2.00	50.8
Minimum Width	6	152
Width Increments	0.66	16.8
Opening Size (approximate)	-	-
Open Area	0%	
Hinge Style	Open	
Drive Method	Center-driven	
Product Notes		
<ul style="list-style-type: none"> • Contact Intralox for precise belt measurements and stock status before designing equipment or ordering a belt. • Smooth, closed upper surface with fully flush edges. • Uses headed rods. • Cam-link designed hinges - expose more hinge and rod area as the belt goes around the sprocket. This exclusive Intralox feature allows unsurpassed cleaning access to this area. • Fully sculpted and radiused corners - no pockets or sharp corners to catch and hold debris. • Like Series 1600 and Series 1800, the drive bar on the underside of Series 800 Open Hinge Flat Top channels water and debris to the outside of the belt for easier, faster cleanup. The drive bar's effectiveness has been proven both in-house and in field tests. • Fully compatible with industry-proven Series 800 Flat Top – can be spliced directly into Series 800 Flat Top, using the same sprockets and accessories. • Streamlined flights are available. Standard height is 6 in (152.4 mm) or they can be cut down to custom heights. • Belts over 36 in (914 mm) are built with multiple modules per row, but seams are minimized. 		
Additional Information		
<ul style="list-style-type: none"> • See “Belt Selection Process” (page 5) • See “Standard Belt Materials” (page 9) • See “Special Application Belt Materials” (page 9) • See “Friction Factors” (page 13) 		

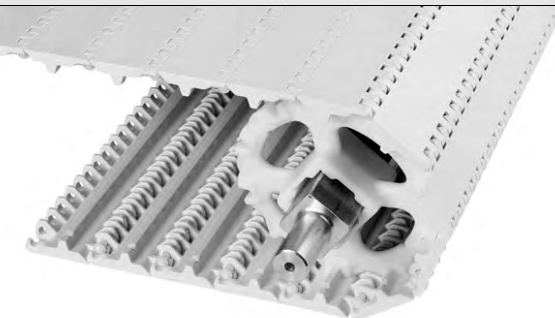
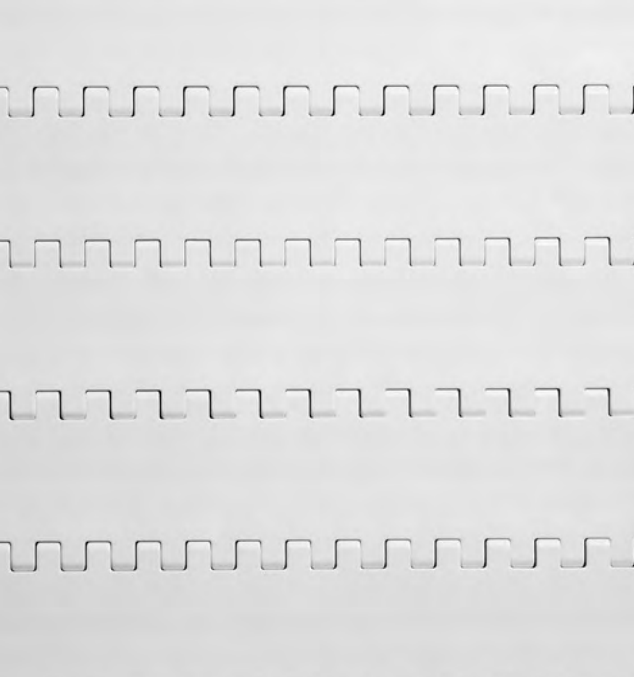
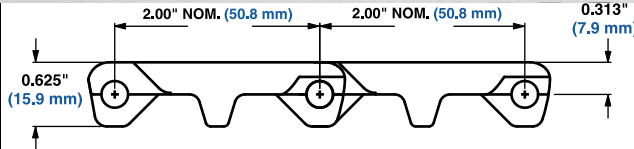



Belt Data									
Belt Material	Standard Rod Material Ø 0.24 in (6.1 mm)	BS	Belt Strength		Temperature Range (continuous)		W	Belt Weight	
			lb/ft	kg/m	°F	°C		lb/ft ²	kg/m ²
Polypropylene	Polypropylene	900	1340	34 to 220	1 to 104	1.63	7.96		
Polyethylene	Polyethylene	500	750	-50 to 150	-46 to 66	1.70	8.30		
Acetal	Polyethylene	900	1340	-50 to 150	-46 to 66	2.52	12.3		
X-Ray Detectable Acetal ^a	Blue Polyethylene	900	1340	-50 to 150	-46 to 66	2.98	13.67		

a. Designed specifically to be detected by x-ray machines.

Tough Flat Top

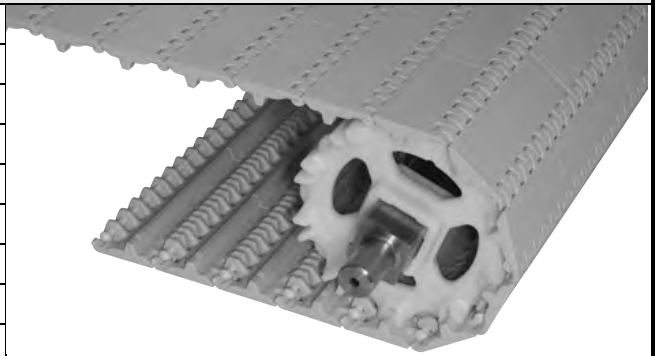
	in	mm
Pitch	2.00	51.0
Minimum Width	2	51
Width Increments	0.66	16.8
Opening Size (approximate)	-	-
Open Area	0%	
Hinge Style	Open	
Drive Method	Center-driven	



Product Notes

- **Contact Intralox for precise belt measurements and stock status before designing equipment or ordering a belt.**
- Smooth, closed upper surface with fully flush edges.
- Uses headed rods.
- Designed to withstand extreme impact applications in food processing.
- Easy retrofit from Series 1800 without extensive conveyor frame changes for most meat industry applications since the A,B,C,E dimensions are within 0.25 in (6 mm) of Series 1800.
- Cam-link designed hinges - expose more hinge and rod area as belt goes around the sprocket. This exclusive Intralox feature allows unsurpassed cleaning access to this area.
- Like Series 1600 and Series 1800, the drive bar on the underside of Series 800 Tough Flat Top channels water and debris to the outside of the belt for easier, faster cleanup. The drive bar's effectiveness has been proven both in-house and in field tests.
- Fully compatible with industry-proven Series 800 Flat Top and Series 800 Open Hinge - can be spliced directly into both styles, using the same sprockets and accessories.
- White and grey material is fully compliant (FDA and EU MC)
- Streamlined Tough flights are available. Standard height is 4 in or (101.6 mm) or 6 in (152.4 mm) or they can be cut down to custom heights. A molded-in 1.3 in (33 mm) indent from the edge is available.

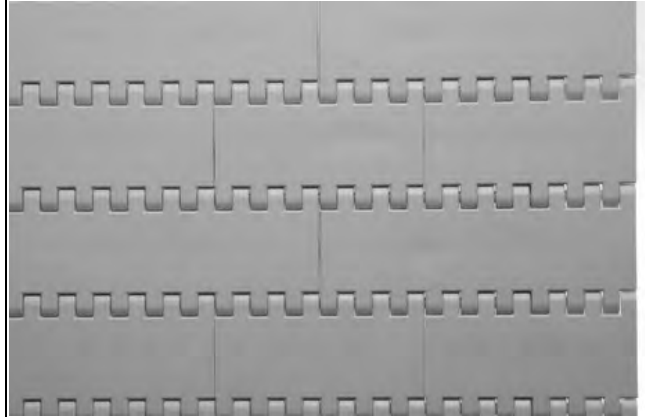

Additional Information

- See "Belt Selection Process" (page 5)
- See "Standard Belt Materials" (page 9)
- See "Special Application Belt Materials" (page 9)
- See "Friction Factors" (page 13)

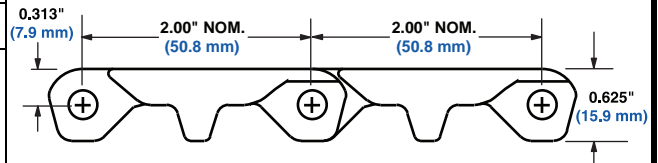

Belt Data

Belt Material	Standard Rod Material Ø 0.24 in (6.1 mm)	BS Belt Strength		Temperature Range (continuous)		W Belt Weight	
		lb/ft	kg/m	°F	°C	lb/ft ²	kg/m ²
Hi-Impact	Acetal	500	744	0 to 120	-18 to 49	2.26	11.03
Hi-Impact	Polyethylene	450	670	0 to 120	-18 to 49	2.26	11.03

Perforated Flat Top		
	in	mm
Pitch	2.00	50.8
Minimum Width	2	51
Width Increments	0.66	16.8
Min. Opening Size (approx.)	0.29 × 0.08	7.4 × 1.9
Max Opening Size (approx.)	0.44 × 0.08	11.1 × 1.9
Open Area	18%	
Hinge Style	Open	
Drive Method	Center-driven	
Product Notes		
<ul style="list-style-type: none"> • Contact Intralox for precise belt measurements and stock status before designing equipment or ordering a belt. • Perforated version of Series 800 Flat Top. • Smooth upper surface with fully flush edges. • Uses headed rods. • Flights and sideguards are available. 		
Additional Information		
<ul style="list-style-type: none"> • See “<i>Belt Selection Process</i>” (page 5) • See “<i>Standard Belt Materials</i>” (page 9) • See “<i>Special Application Belt Materials</i>” (page 9) • See “<i>Friction Factors</i>” (page 13) 		

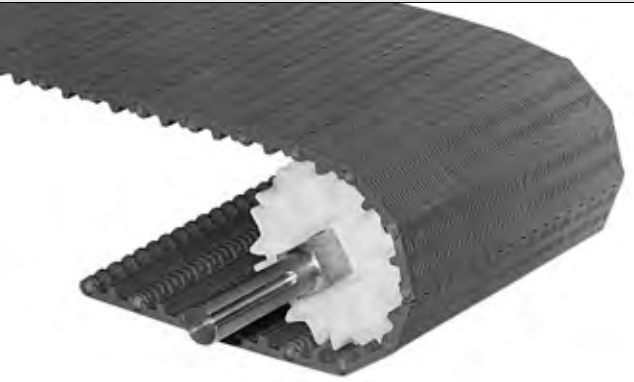
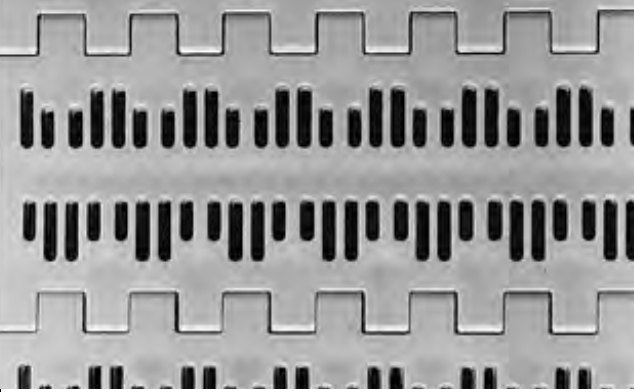
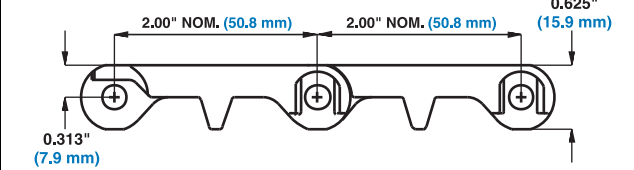
Belt Data							
Belt Material	Standard Rod Material Ø 0.24 in (6.1 mm)	BS Belt Strength		Temperature Range (continuous)		W Belt Weight	
		lb/ft	kg/m	°F	°C	lb/ft ²	kg/m ²
Polypropylene	Polypropylene	1000	1490	34 to 220	1 to 104	1.54	7.25
Polyethylene	Polyethylene	500	750	-50 to 150	-46 to 66	1.59	7.76
Acetal	Polyethylene	900	1340	-50 to 150	-46 to 66	2.28	11.15

Perforated Flat Top Round Hole

	in	mm
Pitch	2.00	50.8
Minimum Width	2	51
Width Increments	0.66	16.8
Opening Size (approximate)	see photos on right	
Open Area	see photos on right	
Hinge Style	Open	
Drive Method	Center-driven	

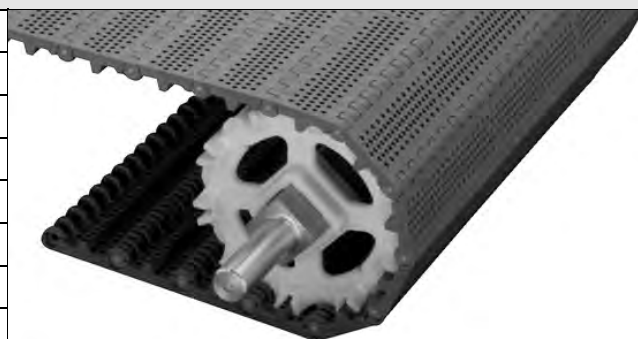

Product Notes

- **Contact Intralox for precise belt measurements and stock status before designing equipment or ordering a belt.**
- Round hole versions of Series 800 Perforated Flat Top.
- Smooth upper surface with fully flush edges.
- Uses headed rods.
- If using this belting in abrasive applications, Intralox recommends Series 800 polyurethane sprockets. Stainless steel split sprockets are not recommended for use with this belt.

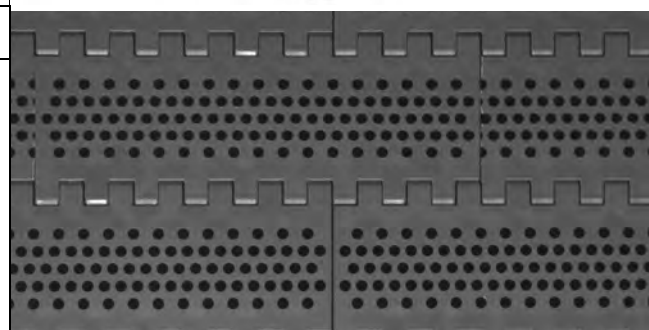

5/32" (4 mm) - 20% Open Area

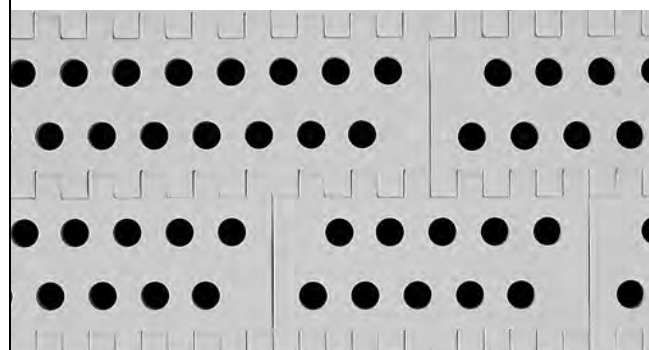

11/32" (8.7 mm) - 14% Open Area

Additional Information

- See "Belt Selection Process" (page 5)
- See "Standard Belt Materials" (page 9)
- See "Special Application Belt Materials" (page 9)
- See "Friction Factors" (page 13)

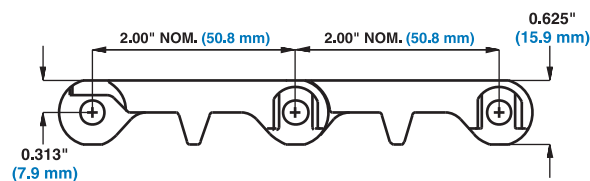

Belt Data

Belt Material	Standard Rod Material Ø 0.24 in (6.1 mm)	BS		Temperature Range (continuous)		W	
		Belt Strength		°F	°C	Belt Weight	
		lb/ft	kg/m			lb/ft ²	kg/m ²
Polypropylene	Polypropylene	1000	1490	34 to 220	1 to 104	1.54	7.52
Polyethylene	Polyethylene	500	750	-50 to 150	-46 to 66	1.59	7.76
Acetal	Polyethylene	900	1340	-50 to 150	-46 to 66	2.28	11.15
CRFR ^a	CRFR	900	1339	0 to 150	-18 to 66	2.87	14.01

a. Only available in 11/32 in.

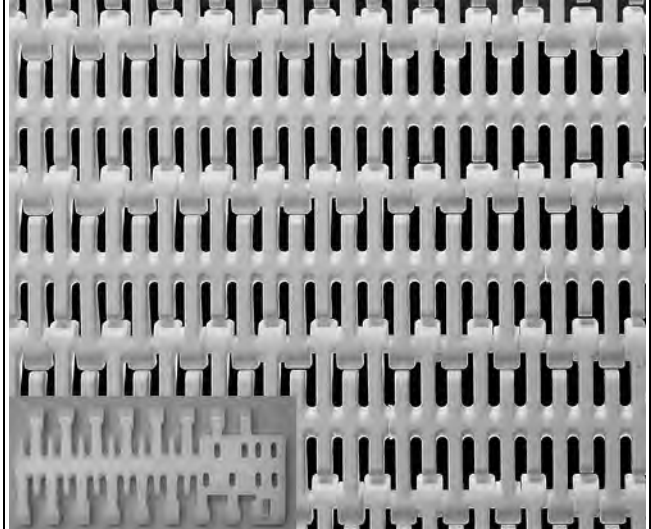
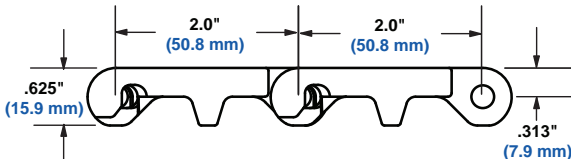
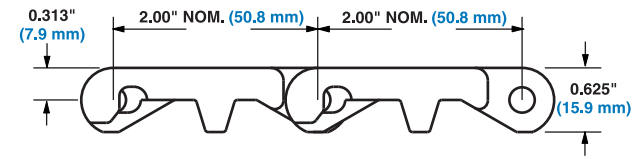
Flush Grid		
	in	mm
Pitch	2.00	50.8
Minimum Width	4.6	117
Width Increments	0.66	16.8
Opening Size (approximate)	0.15 x 0.90	3.8 x 22.9
Open Area	27%	
Product Contact Area	73%	
Hinge Style	Open	
Drive Method	Center-driven	
Product Notes		
<ul style="list-style-type: none"> • Contact Intralox for precise belt measurements and stock status before designing equipment or ordering a belt. • Smooth upper surface with fully flush edges. • Open slots improve drainage and cleanability. • Uses headless rods. • Flights and sideguards available. • Complete range of accessories available, including round-top flights and flights with drainage bases. • Provides excellent drainage during production and cleanup. Hole design eliminates water collecting on belt surface and being carried throughout processing line. • Bi-directional belt design allows sprockets to drive or idle belt in both directions. Reduces chances of installation error. • Perforations on polyethylene edge modules are slightly different. See inset picture. 		
Additional Information		
<ul style="list-style-type: none"> • See "Belt Selection Process" (page 5) • See "Standard Belt Materials" (page 9) • See "Special Application Belt Materials" (page 9) • See "Friction Factors" (page 13) 		
		
 <p>Inset: Polyethylene edge module</p>		
 <p>Drawing for Polyethylene</p>		
 <p>Drawing for all other materials</p>		

Belt Data									
Belt Material	Standard Rod Material Ø 0.24 in (6.1 mm)	BS	Belt Strength		Temperature Range (continuous)		W	Belt Weight	
			lb/ft	kg/m	°F	°C		lb/ft ²	kg/m ²
Polypropylene	Polypropylene	800	1190	34 to 220	1 to 104	1.45	7.08		
Polyethylene	Polyethylene	500	750	-50 to 150	-46 to 66	1.63	7.96		
Acetal	Polyethylene	1000	1490	-50 to 150	-46 to 66	2.25	10.99		
Acetal	Polypropylene	1000	1490	34 to 200	1 to 93	2.25	10.99		
Detectable Polypropylene A22	Polypropylene	500	744	34 to 150	1 to 66	1.71	8.35		
CRFR	CRFR	1000	1488	0 to 150	-18 to 66	2.83	13.82		

Mesh Top™

	in	mm
Pitch	2.00	50.8
Minimum Width	2	51
Width Increments	0.66	16.8
Opening Size (approximate)	0.50 × 0.04	12.7 × 1.0
Open Area	9%	
Hinge Style	Open	
Drive Method	Center-driven	

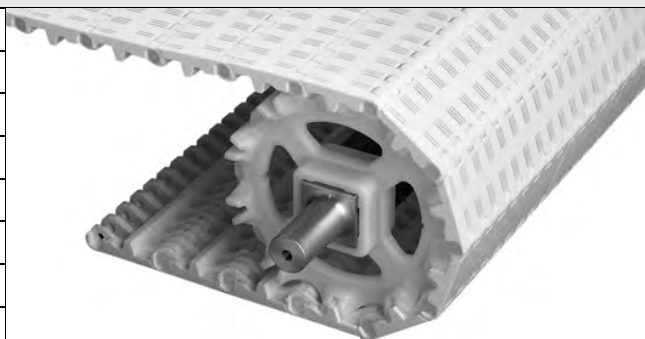

Product Notes

- **Contact Intralox for precise belt measurements and stock status before designing equipment or ordering a belt.**
- Smooth, closed upper surface with fully flush edges.
- Uses headed rods.
- Flights are available.
- Not compatible with sideguards.

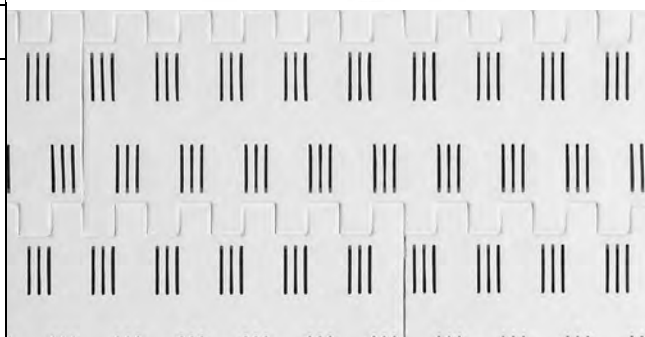

Top Surface

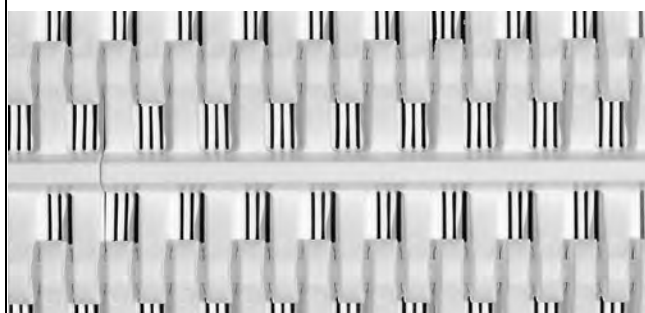

Underside Surface

Additional Information

- See "Belt Selection Process" (page 5)
- See "Standard Belt Materials" (page 9)
- See "Special Application Belt Materials" (page 9)
- See "Friction Factors" (page 13)

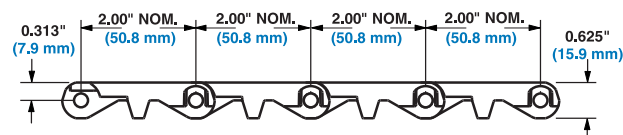

Belt Data

Belt Material	Standard Rod Material Ø 0.24 in (6.1 mm)	BS		Temperature Range (continuous)		W	
		Belt Strength		°F	°C	Belt Weight	
		lb/ft	kg/m			lb/ft ²	kg/m ²
Polypropylene	Polypropylene	1000	1490	34 to 220	1 to 104	1.60	7.86

Mini Rib		
	in	mm
Pitch	2.00	50.8
Minimum Width	2	51
Width Increments	0.66	16.8
Opening Size (approximate)	-	-
Open Area	0%	
Hinge Style	Open	
Drive Method	Center-driven	

Product Notes

- **Contact Intralox for precise belt measurements and stock status before designing equipment or ordering a belt.**
- Closed surface with fully flush edges.
- Uses headed rods.
- Impact resistant belt designed for tough Meat Industry applications.
- 1/8 in (3 mm) Mini Rib on surface accommodates gradual inclines and declines.
- Not recommended for back-up conditions. If values are required, contact Intralox Sales Engineering.

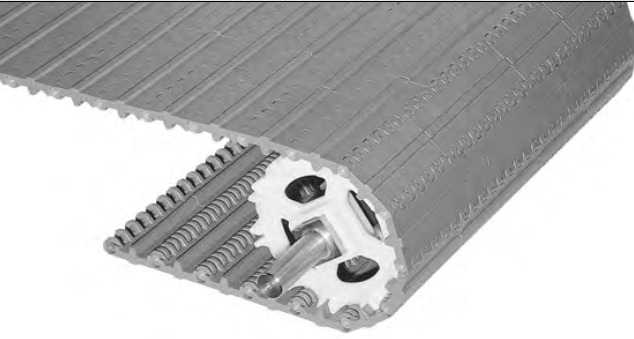
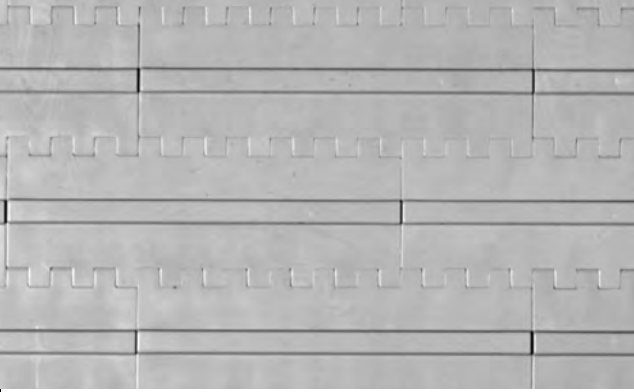
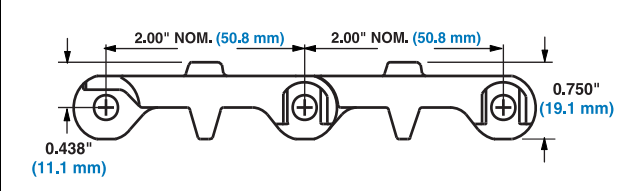
Additional Information		
<ul style="list-style-type: none"> • See "Belt Selection Process" (page 5) • See "Standard Belt Materials" (page 9) • See "Special Application Belt Materials" (page 9) • See "Friction Factors" (page 13) 		

Belt Data							
Belt Material	Standard Rod Material Ø 0.24 in (6.1 mm)	BS Belt Strength		Temperature Range (continuous)		W Belt Weight	
		lb/ft	kg/m	°F	°C	lb/ft ²	kg/m ²
Polypropylene	Polypropylene	1000	1490	34 to 220	1 to 104	1.77	8.66
Polyethylene	Polyethylene	500	750	-50 to 150	-46 to 66	1.87	9.13
Acetal	Polyethylene	900	1340	-50 to 150	-46 to 66	2.92	14.26

Nub Top™

	in	mm
Pitch	2.00	50.8
Minimum Width	4	102
Width Increments	0.66	16.8
Open Area	0%	
Product Contact Area	15%	
Hinge Style	Open	
Drive Method	Center-driven	



Product Notes

- **Contact Intralox for precise belt measurements and stock status before designing equipment or ordering a belt.**
- Closed upper surface with fully flush edges.
- Uses headed rods.
- Standard flights and sideguards (without nubs) are available.
- Nub standard indent is 1.3 in (33.0 mm).
- Not recommended for back-up conditions. If values are required, contact Intralox Sales Engineering.

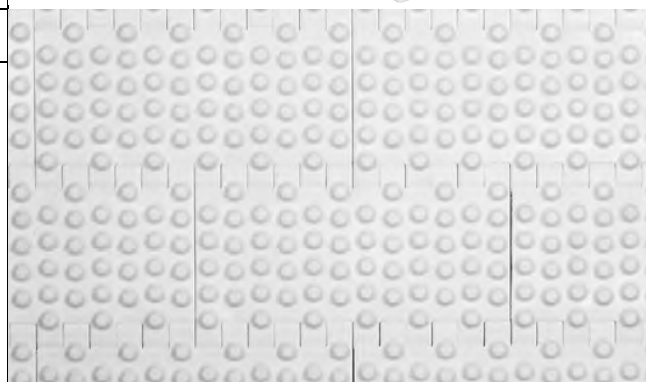

Additional Information

- See "Belt Selection Process" (page 5)
- See "Standard Belt Materials" (page 9)
- See "Special Application Belt Materials" (page 9)
- See "Friction Factors" (page 13)

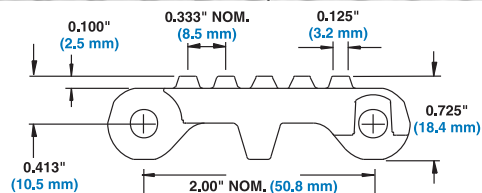

Belt Data

Belt Material	Standard Rod Material Ø 0.24 in (6.1 mm)	BS Belt Strength		Temperature Range (continuous)		W Belt Weight	
		lb/ft	kg/m	°F	°C	lb/ft²	kg/m²
Polypropylene	Polypropylene	1000	1490	34 to 220	1 to 104	1.90	9.26
Polyethylene	Polyethylene	500	750	-50 to 150	-46 to 66	2.01	9.80
Acetal	Polyethylene	900	1340	-50 to 150	-46 to 66	2.95	14.40

Flush Grid Nub Top™

	in	mm
Pitch	2.00	50.8
Minimum Width	4.6	117
Width Increments	0.66	16.8
Opening Size (approximate)	0.15 × 0.90	3.8 × 22.9
Open Area	27%	
Product Contact Area	15%	
Hinge Style	Open	
Drive Method	Center-driven	

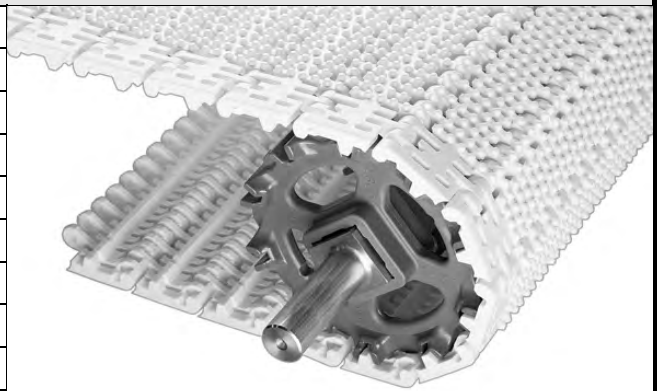

Product Notes

- **Contact Intralox for precise belt measurements and stock status before designing equipment or ordering a belt.**
- Standard Nub indent is 1.3 inches (33.0 mm).
- Uses headless rods.
- Nub pattern reduces contact between belt surface and product.
- Can be fitted with Series 800 Flush Grid flights only.
- Manufactured in acetal and polypropylene.
- Recommended for products large enough to span the distance between the nubs.
- Nub pattern is continuous over the surface of the belt, even over the hinges.
- Perforations on polyethylene edge modules are slightly different. See inset picture.

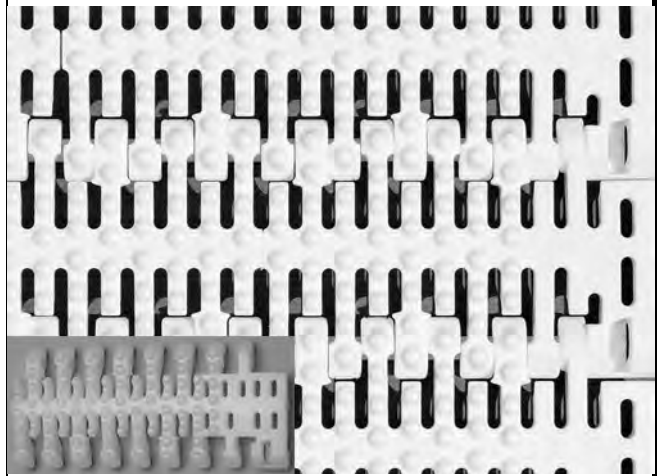

Additional Information

- See “Belt Selection Process” (page 5)
- See “Standard Belt Materials” (page 9)
- See “Special Application Belt Materials” (page 9)
- See “Friction Factors” (page 13)

Inset: Polyethylene edge module

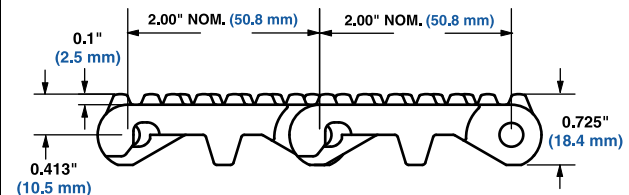

Belt Data

Belt Material	Standard Rod Material Ø 0.24 in (6.1 mm)	BS Belt Strength		Temperature Range (continuous)		W Belt Weight	
		lb/ft	kg/m	°F	°C	lb/ft ²	kg/m ²
Polypropylene	Polypropylene	800	1190	34 to 220	1 to 104	1.56	7.62
Acetal	Polyethylene	1000	1490	-50 to 150	-46 to 66	2.36	11.52
Acetal	Polypropylene	1000	1490	34 to 200	1 to 93	2.36	11.52
Polyethylene	Polyethylene	500	750	-50 to 150	-46 to 66	1.85	9.03

SeamFree™ Open Hinge Nub Top™

	in	mm
Pitch	2.00	50.8
Minimum Width	6	152
Width Increments	0.66	16.8
Opening Sizes (approx.)	-	-
Open Area	0%	
Hinge Style	Open	
Drive Method	Center-Driven	

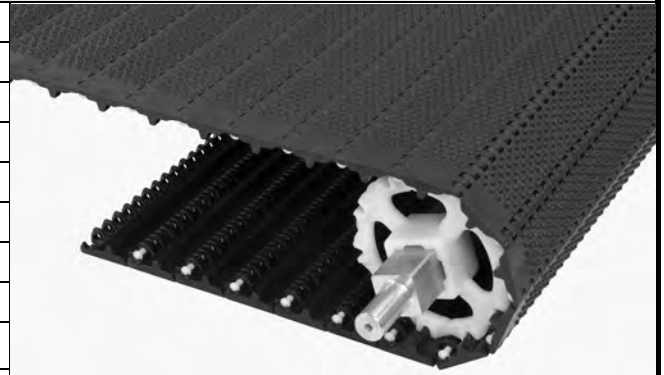

Product Notes

- **Contact Intralox for precise belt measurements and stock status before designing equipment or ordering a belt.**
- Nub height is 0.100 in (2.5 mm).
- Nub spacing is 0.333 in (8.5 mm).
- Standard nub indent is 1.3 in (33.0 mm).
- Closed upper surface with fully flush edges.
- Uses headed rods.
- Cam-link designed hinges expose more hinge and rod area as the belt goes around the sprocket. This exclusive Intralox feature allows unsurpassed cleaning access to this area.
- Fully sculpted and radiused corners - no pockets or sharp corners to catch and hold debris.
- Like Series 800 and Series 1800, the drive bar on the underside of Series 800 SeamFree Open Hinge Nub Top channels water and debris to the outside of the belt for easier, faster cleanup. The drive bar's effectiveness has been proven both in-house and in field tests.
- Not recommended for back-up conditions. If values are required, contact Intralox Sales Engineering.

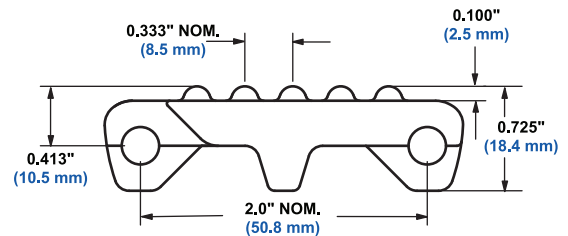
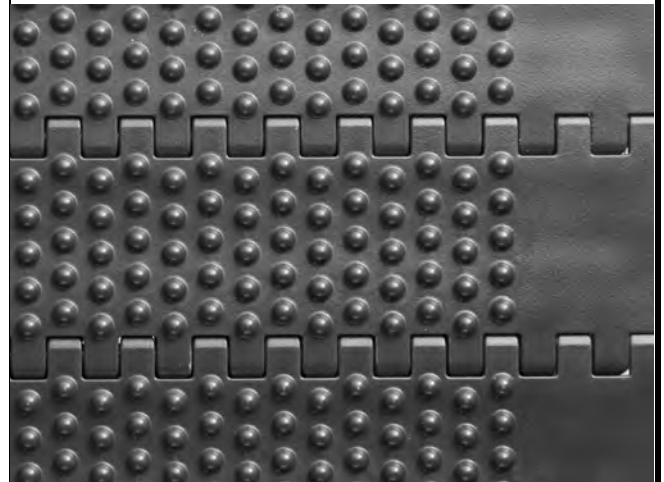

Additional Information

- See "Belt Selection Process" (page 5)
- See "Standard Belt Materials" (page 9)
- See "Special Application Belt Materials" (page 9)
- See "Friction Factors" (page 13)

Belt Data

Belt Material	Standard Rod Material Ø 0.24 in (6.1 mm)	BS Belt Strength		Temperature Range (continuous)		W Belt Weight	
		lb/ft	kg/m	°F	°C	lb/ft ²	kg/m ²
Polypropylene	Polypropylene	900	1340	34 to 220	1 to 104	1.76	8.58
Polyethylene	Polyethylene	500	750	-50 to 150	-46 to 66	1.84	8.97
Acetal	Polyethylene	900	1340	-50 to 150	-46 to 66	2.72	13.26

Cone Top™		
	in	mm
Pitch	2.00	50.8
Minimum Width	4	102
Width Increments	0.66	16.8
Opening Size (approximate)	-	-
Open Area	0%	
Hinge Style	Open	
Drive Method	Center-driven	
Product Notes		
<ul style="list-style-type: none"> • Contact Intralox for precise belt measurements and stock status before designing equipment or ordering a belt. • Closed upper surface with fully flush edges. • Uses headed rods. • Standard flights and sideguards (without cones) are available. • Cone standard indent is 1.3 in (33.0 mm). • Not recommended for back-up conditions. If values are required, contact Intralox Sales Engineering. 		
Additional Information		
<ul style="list-style-type: none"> • See “Belt Selection Process” (page 5) • See “Standard Belt Materials” (page 9) • See “Special Application Belt Materials” (page 9) • See “Friction Factors” (page 13) 		

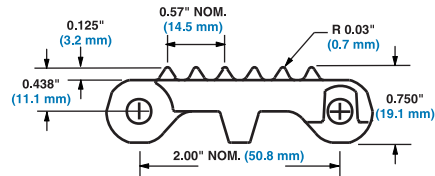
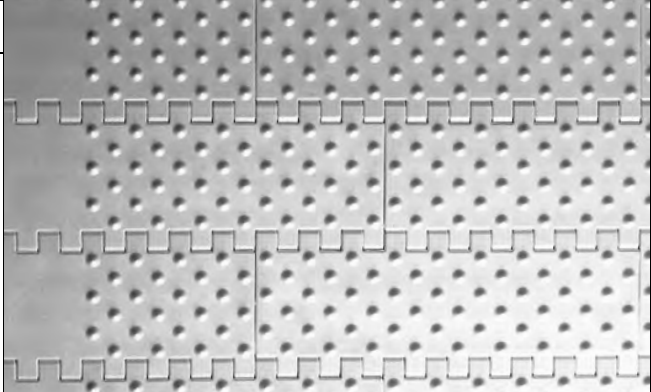
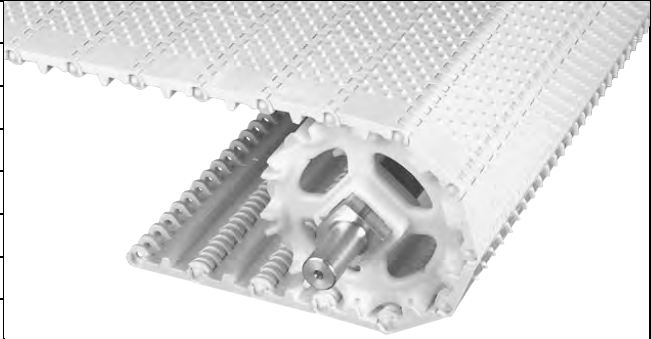

Belt Data							
Belt Material	Standard Rod Material Ø 0.24 in (6.1 mm)	BS	Belt Strength	Temperature Range (continuous)		W	Belt Weight
				lb/ft	kg/m		
Acetal	Polyethylene	900	1340	-50 to 150	-46 to 66	2.84	13.89

Open Hinge Cone Top™

	in	mm
Pitch	2.00	50.8
Minimum Width	6	152
Width Increments	0.66	16.8
Opening Size (approximate)	-	-
Open Area	0%	
Hinge Style	Open	
Drive Method	Center-driven	



Product Notes

- **Contact Intralox for precise belt measurements and stock status before designing equipment or ordering a belt.**
- Cone standard indent is 1.3 in (33.0 mm).
- Closed upper surface with fully flush edges.
- Uses headed rods.
- Cam-link designed hinges - expose more hinge and rod area as the belt goes around the sprocket. This exclusive Intralox feature allows unsurpassed cleaning access to this area.
- Fully sculpted and radiused corners - no pockets or sharp corners to catch and hold debris.
- Like Series 800 and Series 1800, the drive bar on the underside of Series 800 Open Hinge Cone Top channels water and debris to the outside of the belt for easier, faster cleanup. The drive bar's effectiveness has been proven both in-house and in field tests.
- Standard flights and sideguards (without cones) are available.
- Not recommended for back-up conditions. If values are required, contact Intralox Sales Engineering.

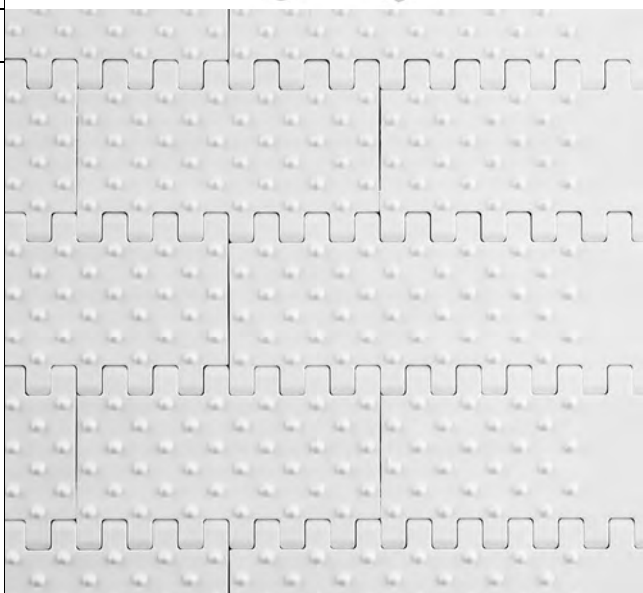

Additional Information

- See "Belt Selection Process" (page 5)
- See "Standard Belt Materials" (page 9)
- See "Special Application Belt Materials" (page 9)
- See "Friction Factors" (page 13)

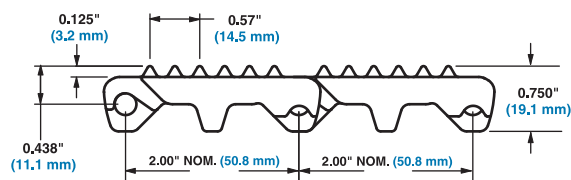

Belt Data

Belt Material	Standard Rod Material Ø 0.24 in (6.1 mm)	BS Belt Strength		Temperature Range (continuous)		W Belt Weight	
		lb/ft	kg/m	°F	°C	lb/ft ²	kg/m ²
Polypropylene	Polypropylene	900	1340	34 to 220	1 to 104	1.63	7.96
Polyethylene	Polyethylene	500	740	-50 to 150	-46 to 66	1.70	8.30
Acetal	Polyethylene	900	1340	-50 to 150	-46 to 66	2.52	12.3

SeamFree™ Open Hinge Cone Top™		
	in	mm
Pitch	2.00	50.8
Minimum Width	6	152
Width Increments	0.66	16.8
Opening Sizes (approx.)	-	-
Open Area	0%	
Hinge Style	Open	
Drive Method	Center-Driven	
Product Notes		
<ul style="list-style-type: none"> • Contact Intralox for precise belt measurements and stock status before designing equipment or ordering a belt. • Cone height is 0.125 in (3.2 mm). • Cone spacing is 0.295 in (7.5 mm). • Standard cone indent is 1.3 in (33 mm). • Closed upper surface with fully flush edges. • Uses headed rods. • Cam-link designed hinges expose more hinge and rod area as the belt goes around the sprocket. This exclusive Intralox feature allows unsurpassed cleaning access to this area. • Fully sculpted and radiused corners - no pockets or sharp corners to catch and hold debris. • Like Series 800 and Series 1800, the drive bar on the underside of Series 800 SeamFree Open Hinge Cone Top channels water and debris to the outside of the belt for easier, faster cleanup. The drive bar's effectiveness has been proven both in-house and in field tests. • Not recommended for back-up conditions. If values are required, contact Intralox Sales Engineering. 		
Additional Information		
<ul style="list-style-type: none"> • See "Belt Selection Process" (page 5) • See "Standard Belt Materials" (page 9) • See "Special Application Belt Materials" (page 9) • See "Friction Factors" (page 13) 		

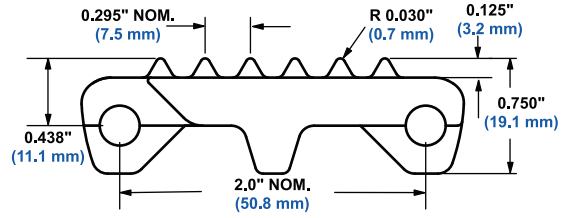
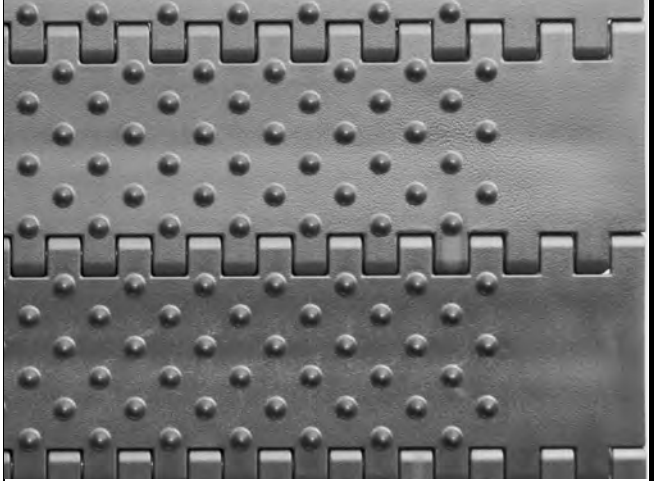
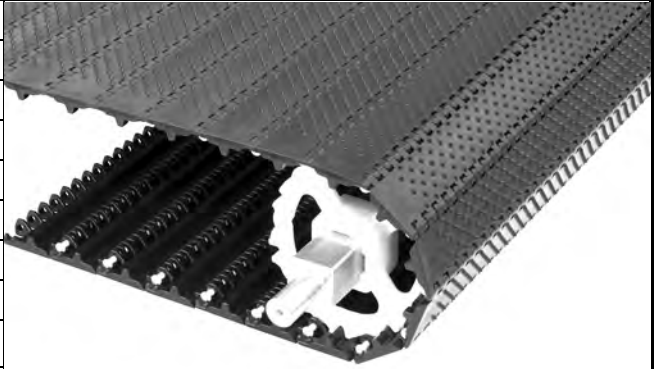

Belt Data							
Belt Material	Standard Rod Material Ø 0.24 in (6.1 mm)	BS Belt Strength		Temperature Range (continuous)		W Belt Weight	
		lb/ft	kg/m	°F	°C	lb/ft²	kg/m²
Acetal	Polyethylene	900	1340	-50 to 150	-46 to 66	2.61	12.72

Raised Rib

	in	mm
Pitch	2.00	50.8
Minimum Width	14	356
Width Increments	2.00	50.8
Opening Sizes (approx.)	0.51 x 0.49	12.9 x 12.4
Open Area	40%	
Hinge Style	Open	
Drive Method	Center-Driven	

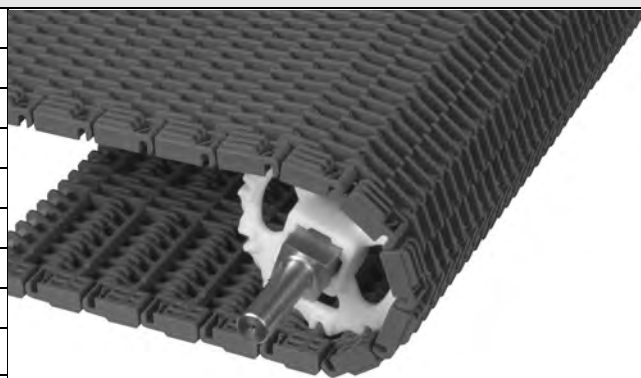

Product Notes

- Contact Intralox for precise belt measurements and stock status before designing equipment or ordering a belt.
- Raised Ribs extend 0.275 in (7.0 mm) above basic module with fully flush edges.
- Open slots improve drainage and cleanability.
- Finger transfer plates are available.
- Fully compatible with Series 800 EZ Clean™ angled sprockets.
- Cam-link design hinges provide easy cleaning with greater hinge and rod exposure as the belt moves around the sprockets.
- Uses headless rods.

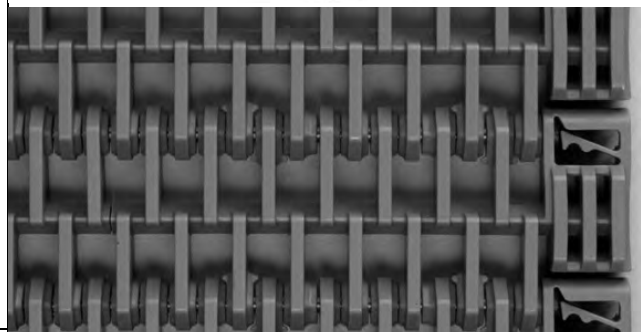

Additional Information

- See "Belt Selection Process" (page 5)
- See "Standard Belt Materials" (page 9)
- See "Special Application Belt Materials" (page 9)
- See "Friction Factors" (page 13)

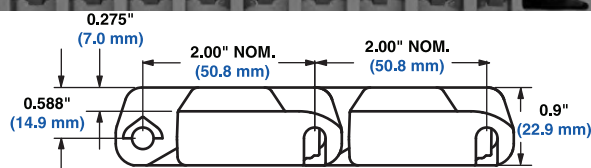

Belt Data

Belt Material	Standard Rod Material Ø 0.24 in (6.1 mm)	BS		Temperature Range (continuous)		W	
		Belt Strength		°F	°C	Belt Weight	
		lb/ft	kg/m			lb/ft ²	kg/m ²
Polypropylene	Polypropylene	1000	1490	34 to 220	1 to 104	1.48	7.23
Enduralox™ PP	Polypropylene	1000	1490	34 to 220	1 to 104	1.48	7.23

Roller Top™		
	in	mm
Pitch	2.00	50.8
Minimum Width	See Product Notes	
Width Increments	See Product Notes	
Opening Size (approximate)	-	-
Open Area	3%	
Hinge Style	Open	
Drive Method	Center-driven	
Product Notes		
<ul style="list-style-type: none"> • Contact Intralox for precise belt measurements and stock status before designing equipment or ordering a belt. • Fully flush edges. • Uses headed rods. • Impact resistant belt designed for tough box and package, low back pressure applications. • Back-up load is 5-10% of product weight. • Acetal rollers, stainless steel axles. • Roller diameter - 0.70 in (17.8 mm). Roller length - 0.825 in (20.9 mm). • Roller spacing - 2.0 in (50.8 mm). • Standard roller indent is 0.60 in (15 mm) • Custom-built in widths of 4 in (102 mm) and 6 in (152 mm) and from 10 in (254 mm) and up in 2.00 in (50.8 mm) increments. 		
Additional Information		
<ul style="list-style-type: none"> • See "Belt Selection Process" (page 5) • See "Standard Belt Materials" (page 9) • See "Special Application Belt Materials" (page 9) • See "Friction Factors" (page 13) 		

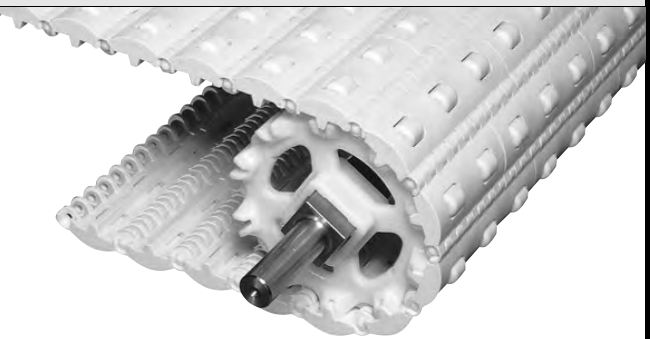
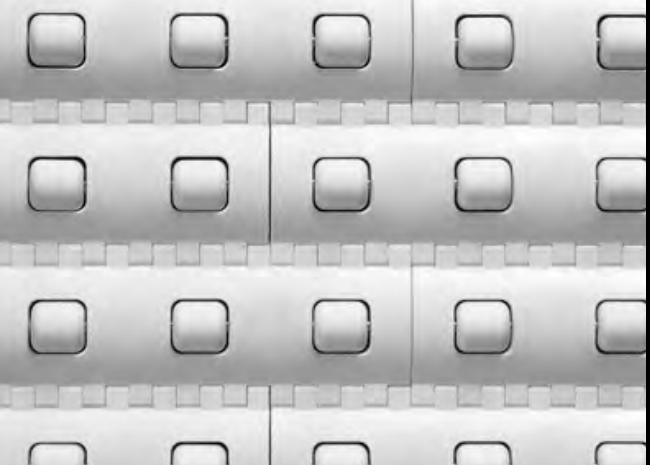
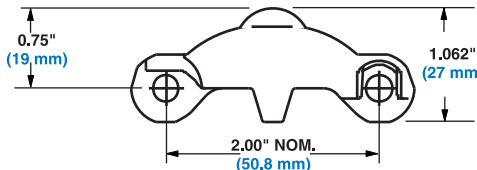
Belt Data							
Belt Material	Standard Rod Material Ø 0.24 in (6.1 mm)	BS Belt Strength		Temperature Range (continuous)		W Belt Weight	
		lb/ft	kg/m	°F	°C	lb/ft²	kg/m²
Polypropylene	Acetal	1000	1490	34 to 200	1 to 93	2.93	14.34
Polyethylene	Acetal	500	750	-50 to 150	-46 to 66	2.99	14.62
Acetal	Acetal	900	1340	-50 to 150	-46 to 66	4.11	20.10

Rounded Friction Top		
	in	mm
Pitch	2.00	50.8
Minimum Width	8	203
Width Increments	0.66	16.8
Opening Size (approximate)	-	-
Open Area	0%	
Hinge Style	Open	
Drive Method	Center-driven	
Product Notes		
<ul style="list-style-type: none"> • Contact Intralox for precise belt measurements and stock status before designing equipment or ordering a belt. • No mistracking or "stick-slip" effect, even on long runs: The Intralox belt is positively tracked by Intralox's sprocket drive system instead of unreliable friction rollers. • Thermally bonded rubber will not peel off: Only Intralox's Friction Top surface is co-molded (thermally bonded) with the plastic base instead of glued on or mechanically fastened. The Rounded Friction Top module is black rubber on a white PP composite base module. • Rounded Friction Top module can be used with other S800 styles. The belt strength rating that should be used is that of the accompanying modules. • Easy to maintain and repair: Intralox's reusable headless rods are quickly removed and installed with only minimal tools, so one can replace individual modules in minutes. • Uses headless rods. • No tensioning required, which eliminates expensive tensioning systems. • Lower construction cost: Intralox's sprocket drive requires far less space than a friction roller system, allowing shallow, less expensive trench construction. • Lower wearstrip replacement cost: Flat Top edge modules prevent premature wearstrip erosion-the smooth surface spans 38.1 mm (1.5") from the outer edge. 		
Additional Information		
<ul style="list-style-type: none"> • See "Belt Selection Process" (page 5) • See "Standard Belt Materials" (page 9) • See "Special Application Belt Materials" (page 9) • See "Friction Factors" (page 13) 		

Belt Data									
Base Belt Material	Base/Friction Color	Standard Rod Material Ø 0.24 in (6.1 mm)	BS Belt Strength		Temperature Range (continuous)		W Belt Weight		Friction Top Hardness
			lb/ft	kg/m	°F	°C	lb/ft ²	kg/m ²	
Polypropylene Composite	White/Black	Acetal	2500	3713	-50 to 150	-46 to 66	2.3	11.25	-

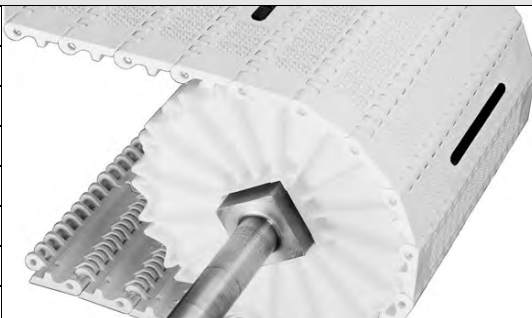
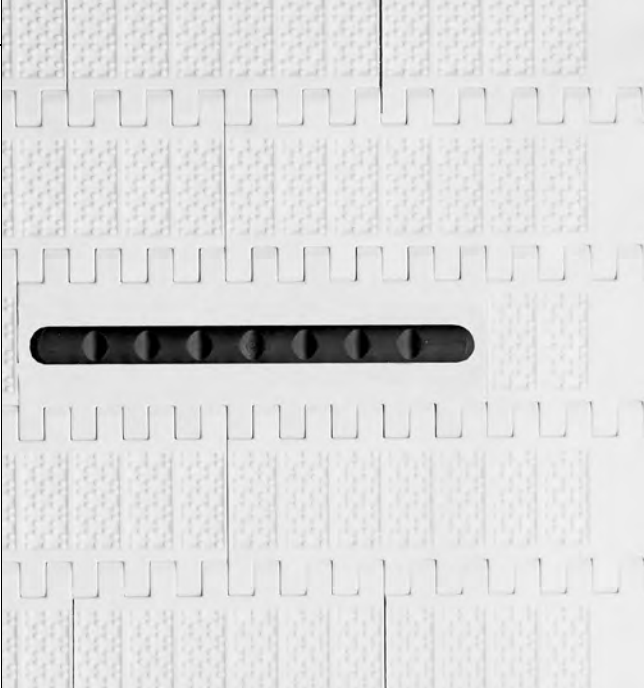
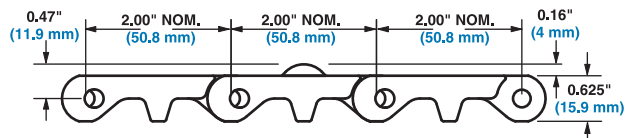
Sprocket and Support Quantity Reference				
Belt Width Range ^a		Minimum Number of Sprockets Per Shaft ^b	Wearstrips	
in.	mm		Carryway	Returnway
2	51	1	2	2
4	102	1	2	2
6	152	2	2	2
8	203	2	2	2
10	254	2	3	2
12	305	3	3	2
14	356	3	3	3
16	406	3	3	3
18	457	3	3	3
20	508	5	4	3
24	610	5	4	3
30	762	5	5	4
32	813	7	5	4
36	914	7	5	4
42	1067	7	6	5
48	1219	9	7	5
54	1372	9	7	6
60	1524	11	8	6
72	1829	13	9	7
84	2134	15	11	8
96	2438	17	12	9
120	3048	21	15	11
144	3658	25	17	13
For Other Widths, Use Odd Number of Sprockets ^c at Maximum 6 in. (152 mm) \varnothing Spacing			Maximum 9 in. (229 mm) \varnothing Spacing	Maximum 12 in. (305 mm) \varnothing Spacing

- a. If your belt width exceeds a number listed in the table, please refer to the sprocket and support material minimums for the next larger width range listed. Belts are available in 0.66 in. (16.8 mm) increments beginning with minimum width of 2 in. (51 mm). **If the actual width is critical, consult Customer Service.**
- b. These are the minimum number of sprockets. Additional sprockets may be required for heavily loaded applications. Polyurethane sprockets require a maximum 4 in. (102 mm) centerline spacing.
- c. The center sprocket should be locked down. With only two sprockets, fix the sprocket on the drive journal side only. See Retainer Rings/Center Sprocket Offset chart on page 410 for lock down location.

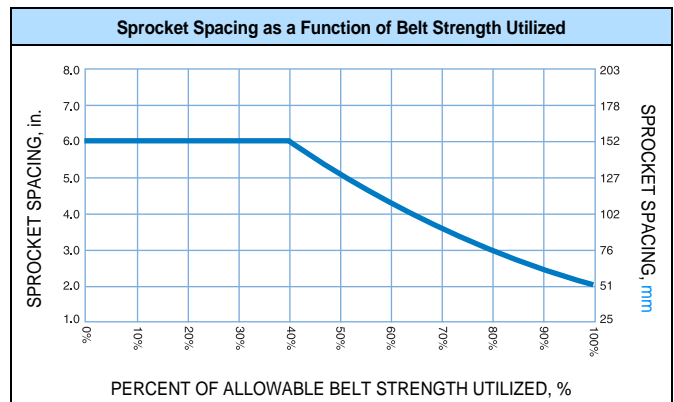
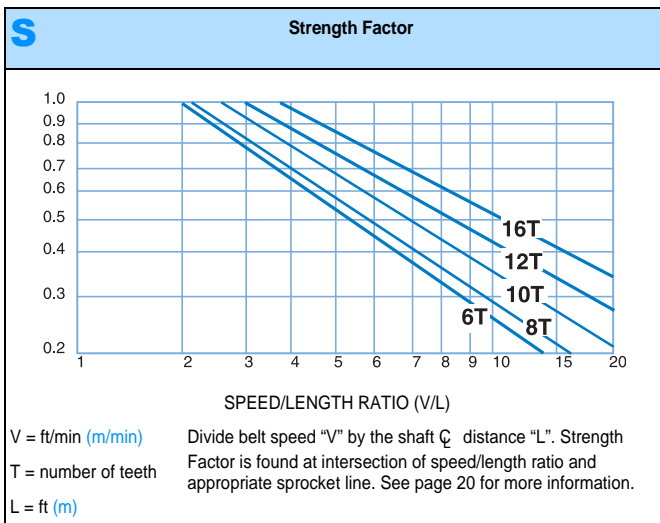

EZ Clean Sprocket^a

No. of Teeth (Chordal Action)	Nom. Pitch Dia. in	Nom. Pitch Dia. mm	Nom. Outer Dia. in	Nom. Outer Dia. mm	Nom. Hub Width in	Nom. Hub Width mm	Available Bore Sizes			
							U.S. Sizes		Metric Sizes	
							Round in ^b	Square in	Round mm ^b	Square mm
6 (13.40%)	4.0	102	3.8	97	1.5	38	1.0	1.5	30	40
8 (7.61%)	5.2	132	5.0	127	1.5	38	1.0	1.5	30	40
10 (4.89%)	6.5	165	6.2	157	1.5	38		1.5		40
12 (3.41%)	7.7	196	7.5	191	1.5	38		1.5		40
16 (1.92%)	10.3	262	10.1	257	1.5	38		1.5		40



- a. Contact Customer Service for lead times. When using Polyurethane sprockets, the Belt Strength for belts rated over 750 lb/ft (1120 kg/m) will be de-rated to 750 lb/ft (1120 kg/m) and all other belts will maintain their published rating. The temperature range for Polyurethane sprockets is 0° F (-18 °C) to 120 °F (49 °C). Contact Customer Service for availability of Polyurethane sprockets.
- b. Imperial key sizes on round bore sprockets conform to ANSI standard B17.1-1967 (R1989) and metric key sizes conform to DIN standard 6885

Split Ultra Abrasion Resistant Polyurethane (FDA) Sprocket^a

No. of Teeth (Chordal Action)	Nom. Pitch Dia. in	Nom. Pitch Dia. mm	Nom. Outer Dia. in	Nom. Outer Dia. mm	Nom. Hub Width in	Nom. Hub Width mm	Available Bore Sizes			
							U.S. Sizes		Metric Sizes	
							Round in ^b	Square in	Round mm ^b	Square mm
10 (4.89%)	6.5	165	6.2	157	1.5	38		1.5		40
12 (3.41%)	7.7	196	7.5	191	1.5	38		1.5		40
								2.5		60
16 (1.92%)	10.3	262	10.1	257	1.5	38		1.5		40
								2.5		60

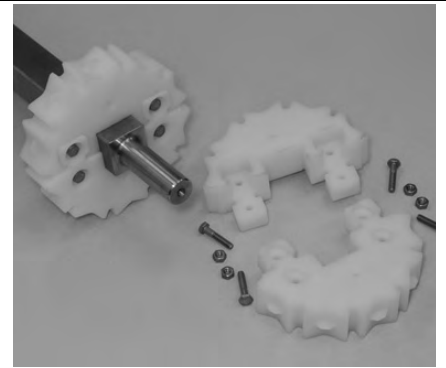

- a. Contact Customer Service for lead times. When using Polyurethane sprockets, the Belt Strength for belts rated over 750 lb/ft (1120 kg/m) will be de-rated to 750 lb/ft (1120 kg/m) and all other belts will maintain their published rating. The temperature range for Polyurethane sprockets is 0° F (-18 °C) to 120 °F (49 °C). Contact Customer Service for availability of Polyurethane sprockets. These sprockets are FDA approved.
- b. Imperial key sizes on round bore sprockets conform to ANSI standard B17.1-1967 (R1989) and metric key sizes conform to DIN standard 6885

Molded Sprocket^a

No. of Teeth (Chordal Action)	Nom. Pitch Dia. in	Nom. Pitch Dia. mm	Nom. Outer Dia. in	Nom. Outer Dia. mm	Nom. Hub Width in	Nom. Hub Width mm	Available Bore Sizes			
							U.S. Sizes		Metric Sizes	
							Round in	Square in	Round mm	Square mm
8 (7.61%)	5.2	132	5.0	127	1.5	38		1.5		40
10 (4.89%)	6.5	165	6.2	157	1.5	38		1.5		40
								2.0		60
								2.5		60
12 (3.41%)	7.7	196	7.5	191	1.5	38		1.5		40
								2.5		60
16 (1.92%)	10.3	262	10.1	257	1.5	38		1.5		40
								2.5		60



- a. Contact Customer Service for lead times. When using Polyurethane sprockets, the Belt Strength for belts rated over 750 lb/ft (1120 kg/m) will be de-rated to 750 lb/ft (1120 kg/m) and all other belts will maintain their published rating. The temperature range for Polyurethane sprockets is 0° F (-18 °C) to 120 °F (49 °C). Contact Customer Service for availability of Polyurethane sprockets.

Abrasion Resistant Split Metal Sprocket ^a										
No. of Teeth (Chordal Action)	Nom. Pitch Dia. in	Nom. Pitch Dia. mm	Nom. Outer Dia. in	Nom. Outer Dia. mm	Nom. Hub Width in	Nom. Hub Width mm	Available Bore Sizes			
							U.S. Sizes		Metric Sizes	
							Round in	Square in	Round mm	Square mm
8 (7.61%)	5.2	132	5.0	127	1.7	43		1.5		40
								2.5		60
10 (4.89%)	6.5	165	6.2	157	1.7	43		1.5		40
								2.5		60
12 (3.41%)	7.7	196	7.5	191	1.7	43		1.5		40
								2.5		60
16 (1.92%)	10.3	262	10.1	257	1.7	43		1.5		40
								2.5		60

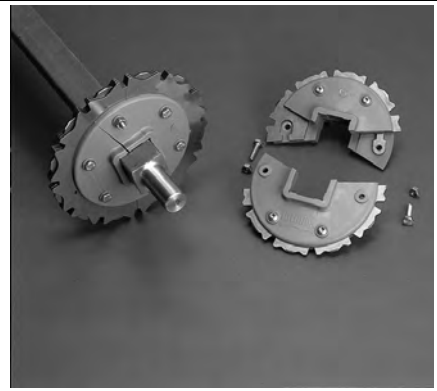

a. Contact Customer Service for lead times.

Angled EZ Clean Sprocket ^a										
No. of Teeth (Chordal Action)	Nom. Pitch Dia. in	Nom. Pitch Dia. mm	Nom. Outer Dia. in	Nom. Outer Dia. mm	Nom. Hub Width in	Nom. Hub Width mm	Available Bore Sizes			
							U.S. Sizes		Metric Sizes	
							Round in	Square in	Round mm	Square mm
6 (13.40%)	4.0	102	3.8	97	2.0	50.8		1.5		40
8 (7.61%)	5.2	132	5.0	127	2.0	50.8		1.5		40
10 (4.89%)	6.5	165	6.2	157	2.0	50.8		1.5		40
12 (3.41%)	7.7	196	7.5	191	2.0	50.8		1.5		40
16 (1.92%)	10.3	262	10.1	257	2.0	50.8		1.5		40
								2.5		60

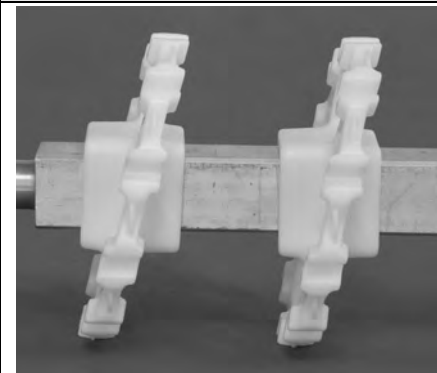

a. Contact Customer Service for lead times. Angled EZ Clean Sprockets can not be used with Series 800 Mesh Top.

Streamline Flights ^a		
Available Flight Height		Available Materials
in	mm	
1	25	Polypropylene, Polyethylene, Acetal, Nylon, Detectable Polypropylene ^b
2	51	
3	76	
4	102	
5	127	
6	152	

Note: Flights can be cut down to custom heights with a minimum height of 0.25 in (13 mm).

Note: Each flight rises out of the center of its supporting module, molded as an integral part. No fasteners are required.

Note: Flat Top flight is smooth (Streamline) on both sides.

Note: The minimum indent (without sideguards) is 1.3 in (33 mm).

Note: An extension can be welded at a 45° angle to create a bent flight.

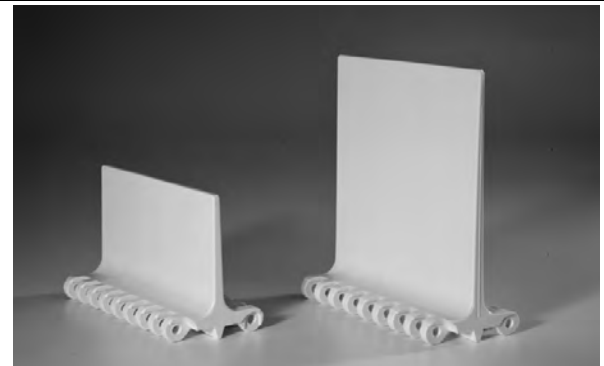

- a. Contact Customer Service for availability.
- b. Detectable Polypropylene can be sensed with metal detection equipment. Testing the material on a metal detector in a production environment is the best method for determining detection sensitivity.

Flat Top Base Flight (No-Cling)

Available Flight Height		Available Materials
in	mm	
4	102	Polypropylene, Polyethylene, Acetal

Note: Flights can be cut down to custom heights with a minimum height of 0.25 in (13 mm).

Note: Each flight rises out of the center of its supporting module, molded as an integral part. No fasteners are required.

Note: The minimum indent (without sideguards) is 1.3 in (33 mm).

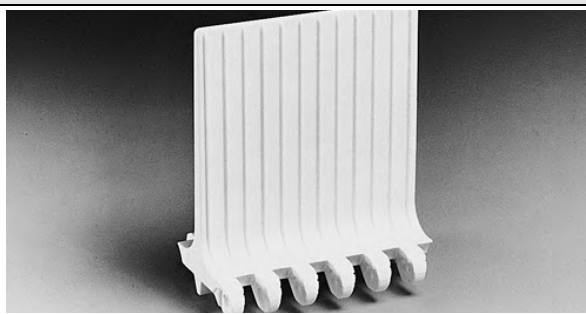

Nub Top Base Flight (Double No-Cling)

Available Flight Height		Available Materials
in	mm	
4	102	Polypropylene, Detectable Polypropylene, Polyethylene, Acetal

Note: Flights can be cut down to custom heights with a minimum height of 0.25 in (13 mm).

Note: Each flight rises out of the center of its supporting module, molded as an integral part. No fasteners are required.

Note: No-Cling vertical ribs are on both sides of the flight.

Note: The minimum indent (without sideguards) is 1.3 in (33 mm).

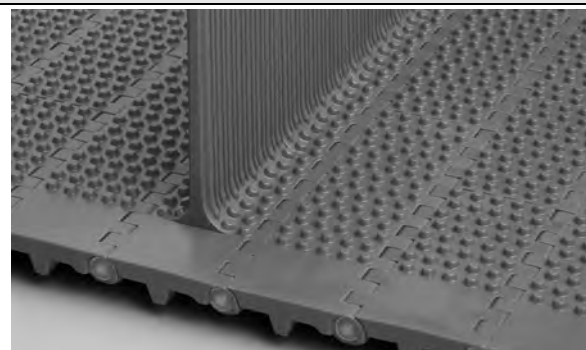

Flush Grid Base Flight (No-Cling)

Available Flight Height		Available Materials
in	mm	
2	51	Polypropylene, Polyethylene, Acetal, CRFR
4	102	

Note: Flights can be cut down to custom heights with a minimum height of 0.25 in (13 mm).

Note: The No-Cling vertical ribs are on both sides of the flight.

Note: Each flight rises out of the center of its supporting module, molded as an integral part. No fasteners are required.

Note: Molded 1.3 in (33 mm) indent available.

Note: The minimum indent (without sideguards) is 1.3 in (33 mm).

Note: These flights cannot be used with the S800 Perforated Flat Top (Slotted version with 18% open area).

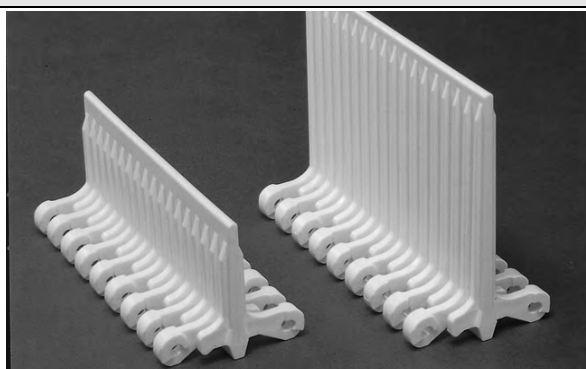

No-Cling Impact Resistant Open Hinge Flight

Available Flight Height		Available Materials
in	mm	
4	102	Acetal, Polypropylene

Note: Flights can be cut down to custom heights with a minimum height of 0.25 in (13 mm).

Note: Each flight rises out of the center of its supporting module, molded as an integral part. No fasteners are required.

Note: The minimum indent (without sideguards) is 1.3 in (33 mm).

Note: Molded 1.3 in (33 mm) indent available.

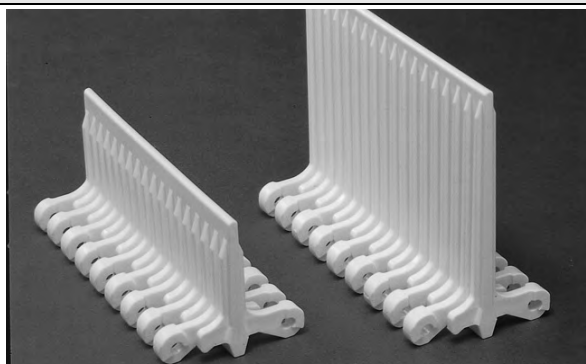

No-Cling Impact Resistant Open Hinge Nub Top Flight

Available Flight Height		Available Materials
in	mm	
4	102	Acetal, Polypropylene

Note: Flights can be cut down to custom heights with a minimum height of 0.25 in (13 mm).

Note: Each flight rises out of the center of its supporting module, molded as an integral part. No fasteners are required.

Note: The minimum indent (without sideguards) is 1.3 in (33 mm).

Note: Molded 1.3 in (33 mm) indent available.

Impact Resistant Flights

Available Flight Height		Available Materials
in	mm	
1	25	Acetal, X-Ray Detectable Acetal
2	51	
3	76	
4	102	

Note: Flights can be cut down to custom heights with a minimum height of 0.25 in (13 mm).

Note: Each flight rises out of its supporting module, molded as an integral part. No fasteners are required.

Note: The minimum indent (without sideguards) is 1.3 in (33 mm).

Open Hinge Impact Resistant Flights

Available Flight Height		Available Materials
in	mm	
4	102	Polypropylene, Detectable Polypropylene, Polyethylene, Acetal, CFRP
6	152	

Note: Each flight rises out of the center of its supporting module. No fasteners are required.

Note: The minimum indent (without sideguards) is 1.3 in (33 mm)

Note: Standard 4 in (102 mm) height can be cut to suit application.

Note: Molded 1.3 in (33 mm) and 2 in (51 mm) indent available.

Tough Flights

Available Flight Height		Available Materials
in	mm	
4	102	Hi-Impact
6	152	

Note: Flights can be cut down to custom heights with a minimum height of 0.25 in (13 mm).

Note: Each flight rises out of the center of its supporting module. No fasteners are required.

Note: The minimum indent (without sideguards) is 1.3 in (33 mm)

Note: Molded 2 in (51 mm) indent available.

Scoop Flights^a

Available Flight Height		Available Materials
in	mm	
3	76	Polypropylene, Polyethylene, Acetal, Nylon, Detectable Polypropylene ^b
4	102	
6	152	



Note: Each flight rises out of its supporting module, molded as an integral part. No fasteners are required.

Note: The minimum indent (without sideguards) is 1.3 in (33 mm).

Note: Bucket flights and Scoop flights can be cut and combined for custom built belts. Contact Customer Service for details.

- a. Contact Customer Service for availability.
- b. Detectable Polypropylene can be sensed with metal detection equipment. Testing the material on a metal detector in a production environment is the best method for determining detection sensitivity.

Bucket Flights^a

Available Flight Height		Available Materials
in	mm	
2.25 ^b	57 ^b	Polypropylene, Polyethylene, Acetal, Detectable Polypropylene ^c
3	76	
4	102	
6	152	

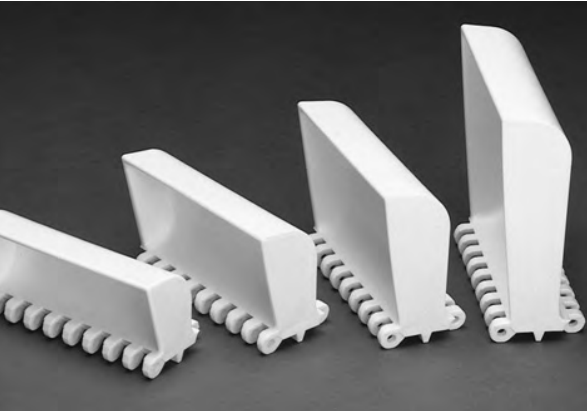

Note: Each flight rises out of its supporting module, molded as an integral part. No fasteners are required.

Note: The minimum indent (without sideguards) is 1.3 in (33 mm).

Note: Bucket flights and Scoop flights can be cut and combined for custom built belts. Contact Customer Service for details.

- a. Contact Customer Service for availability.
- b. 2.25 in (57 mm) Bucket Flight only available in Polypropylene.
- c. Detectable Polypropylene can be sensed with metal detection equipment. Testing the material on a metal detector in a production environment is the best method for determining detection sensitivity.

3-Piece Perforated Bucket and Scoop Flights

Available Flight Height		Available Materials
in	mm	
4	102	Polypropylene, Polyethylene ^a , Acetal ^a

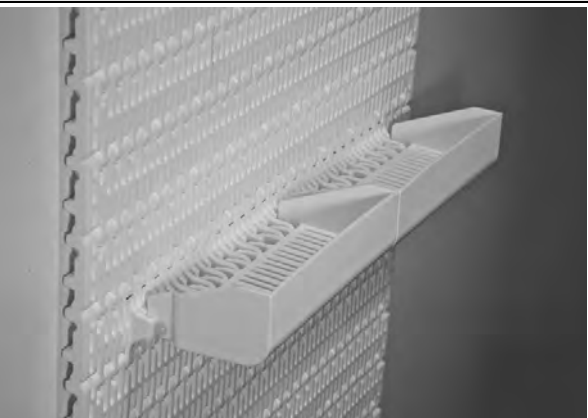

Note: Flights consist of 3 pieces: the base module, the attachment, and the rod.

Note: Flight surface has 30% open area. Opening size (approximate) is 0.130 in (3.3 mm) × 2.40 in (70.0 mm).

Note: Belt surface has 0% open area. Base Module is S800 Flat Top Open Hinge design.

Note: Open slots improve drainage for inclines.

Note: The minimum indent (without Sideguards) is 2.00 in (50.8 mm).

Note: Flights can be cut and combined for custom built belts. Contact Customer Service for details.

Note: Not for use with S800 Perforated Flat Top (slotted version with 18% open area) and S800 Flush Grid Nub Top.

Note: Bucket profile has a 0.27 in (6.9 mm) gap between belt's top surface and bottom surface of bucket side panel.

- a. Contact Customer Service for availability.

Combining Bucket Flights and Scoop Flights

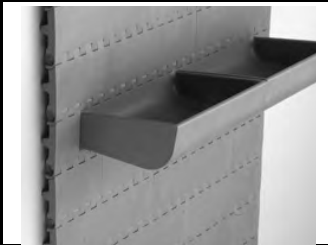
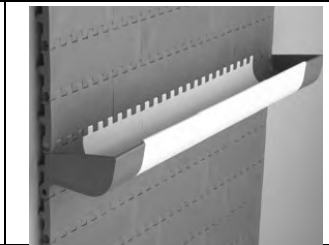
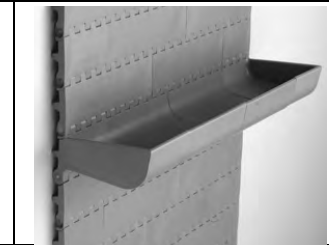
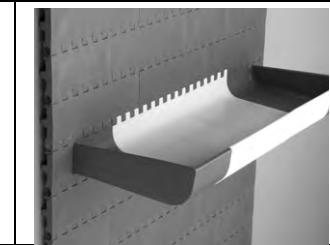
			
6 in (152 mm) bucket flights with indent	3 in (76 mm) bucket flight and scoop flights, no indent	4 in (102 mm) bucket flight and scoop flights, no indent	6 in (152 mm) bucket flight and scoop flights with indent

Note: Bucket flights and Scoop flights can be cut and combined for custom built belts. Contact Customer Service for details.

Tapered Edge

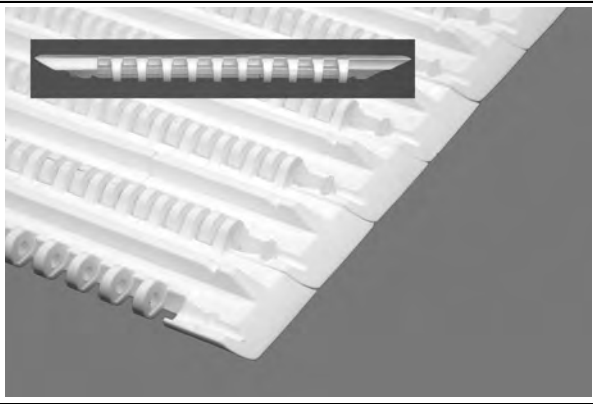
Available Materials	
Polypropylene, Acetal	
<p>Note: Compatible with Series 800 Flat Top and Series 800 Mesh Top</p> <p>Note: Designed to accept headed plastic rods</p> <p>Note: Steel rods will be retained with plastic rodlets</p>	

Threaded Barrel Attachments

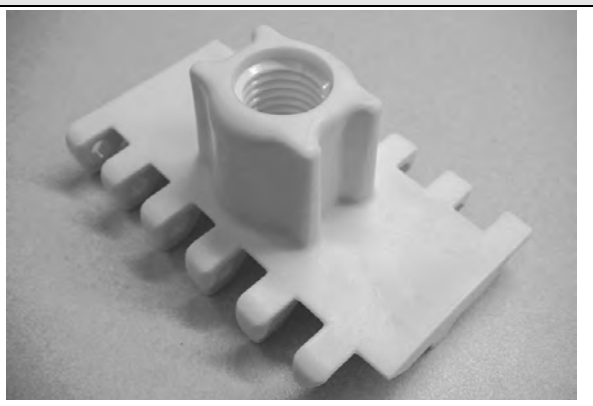
Available Materials	
Acetal	
<p>Note: Attaches to S800 Open Hinge Flat Top modules—4 in (102 mm) wide.</p> <p>Note: 3/4"-10 thread</p> <p>Note: Commonly used on poultry cone assemblies for the manual deboning process.</p>	

Sideguards

Available Sizes		Available Materials
in	mm	
2	51	Polypropylene, Polyethylene, Acetal, Detectable Polypropylene ^a
3	76	
4	102	
6	152	

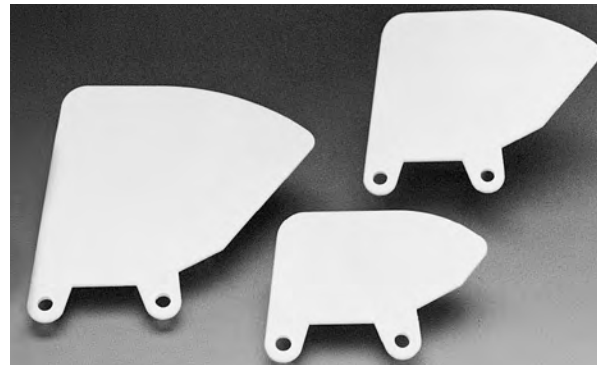

Note: Standard overlapping design and are an integral part of the belt, with no fasteners required.

Note: Fastened by the hinge rods.

Note: The normal gap between the sideguards and the edge of a flight is 0.3 in (8 mm).

Note: When going around the 6 and 8 tooth sprocket, the sideguards will fan out, opening a gap at the top of the sideguard which may allow small products to fall out. The sideguards stay completely closed when going around the 10, 12 and 16 tooth sprockets.

Note: The minimum indent is 0.7 in (18 mm) except for Flush Grid which is 1.3 in (33 mm).

Note: Detectable Polypropylene is only available in 2 in (51 mm) and 4 in (102 mm).

Note: Standard sideguard orientation is angled inward toward the product (product friendly). If needed, sideguards can be angled outward toward the conveyor.

- a. Detectable Polypropylene can be sensed with metal detection equipment. Testing the material on a metal detector in a production environment is the best method for determining detection sensitivity.

Molded-in Sideguards

Available Sizes		Available Materials
in	mm	
4	102	Polypropylene, Polyethylene, Acetal, Detectable Polypropylene ^a

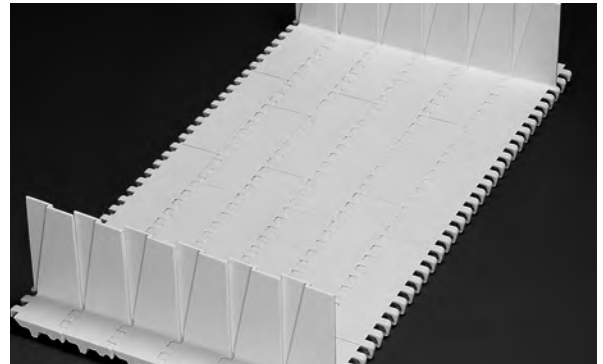

Note: Molded as an integral part of the belt, with no fasteners required.

Note: Part of Intralox's EZ Clean product line.

Note: Standard 4 in (102 mm) height can be cut to suit application.

Note: Overlapping sideguards open fully when wrapping around sprocket, allowing greater access during cleaning. Sideguards will open partially on forward bends of elevating conveyors.

Note: The molded indent is 1.3 in (33 mm).

Note: The minimum backbend radius is 12 in (305 mm).

Note: Sideguards can be spliced into all Series 800 Belt Styles, except Series 800 Perforated Flat Top (18% open Area) and Series 800 Flush Grid Nub Top.

- a. Detectable Polypropylene can be sensed with metal detection equipment. Testing the material on a metal detector in a production environment is the best method for determining detection sensitivity.

Nub Top Molded-in Sideguards

Available Sizes		Available Materials
in	mm	
4	102	Acetal, Polypropylene

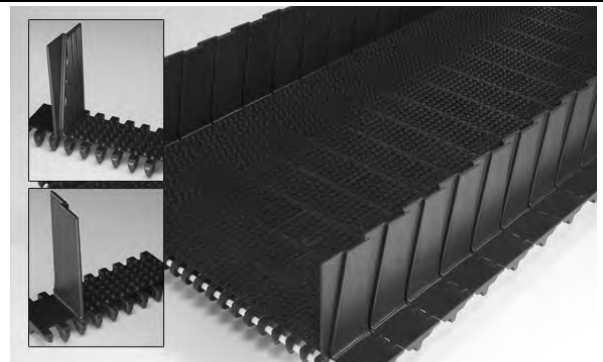

Note: Molded as an integral part of the belt, with no fasteners required.

Note: Part of Intralox's EZ Clean product line.

Note: Standard 4 in (102 mm) height can be cut to suit application.

Note: Nub Top™ design and No Cling rib feature provide a non-stick conveying surface that delivers superior product release and cleanability.

Note: Overlapping sideguards open fully when wrapping around sprocket, allowing greater access during cleaning. Sideguards will open partially on forward bends of elevating conveyors.

Note: The molded indent is 1.3 in (33 mm).

Note: The minimum backbend radius is 10 in (254 mm).

Note: Sideguards can be spliced into all Series 800 Belt Styles, except Series 800 Perforated Flat Top (18% open Area) and Series 800 Flush Grid Nub Top.

Scoop/Bucket Flight Cross Sectional Area for Vertical Incline			
in	mm	sq. in	sq. mm
Scoop Height		Area	
3	76	4.3	2774
4	102	6.0	3871
6	152	9.5	6129
Bucket Height		Area	
2.25	57	2.3	1484
3.00	76	4.3	2774
4.00	102	6.0	3871
6.00	152	9.5	6129

Note: Minimum row spacing is 6 in (152 mm) for 6 in (152 mm) Scoop/Buckets and 4 in (102 mm) for all other sizes.

The diagram shows a cross-section of a scoop/bucket flight. It features a semi-circular scoop with a top edge that is straight and a bottom edge that is curved. The top edge has a radius of R 0.1" (2.5 mm). The bottom edge has a radius of R 1.0" (25.4 mm). The height of the scoop is labeled '1' and the area is labeled '2'. The diagram also shows a bucket with a height of 2" (50.8 mm) and a radius of R 0.3" (7.6 mm). The bucket is attached to a vertical shaft. The diagram is labeled '1 - Height' and '2 - Area'.

Conveyor Frame Dimensions

Regardless of type or configuration, all conveyors using Intralox belts have some basic dimensional requirements. Specifically, dimensions "A", "B", "C" and "E" listed below should be implemented in any design.

For general applications and applications where end transfer of tip-sensitive product is not critical, use the "A" dimension at the bottom of the range.

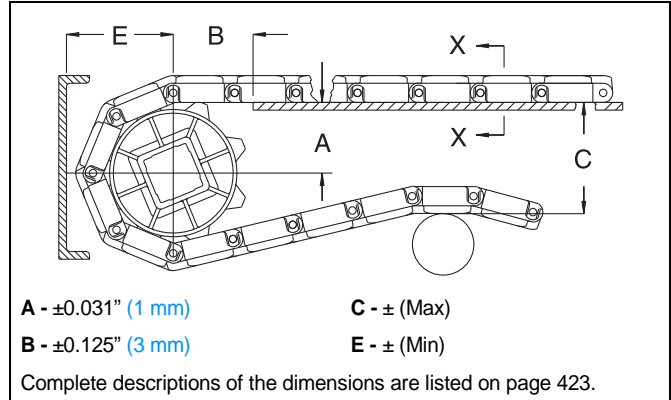

Sprocket Description		A		B		C		E		
Pitch Diameter		No. Teeth	Range (Bottom to Top)		in.	mm	in.	mm	in.	mm
in.	mm		in.	mm						
SERIES 800 FLAT TOP, OPEN HINGE FLAT TOP, SEAMFREE™ OPEN HINGE FLAT TOP, TOUGH FLAT TOP, PERFORATED FLAT TOP (ALL STYLES), FLUSH GRID, MESH TOP										
4.0	102	6	1.42-1.69	36-43	1.73	44	4.00	102	2.38	60
5.2	132	8	2.09-2.29	53-58	2.00	51	5.20	132	2.98	76
6.5	165	10	2.78-2.94	71-75	2.16	55	6.50	165	3.63	92
7.7	196	12	3.41-3.54	87-90	2.45	62	7.70	196	4.23	107
10.3	262	16	4.74-4.84	120-123	2.84	72	10.30	262	5.53	140
SERIES 800 MINI RIB										
4.0	102	6	1.42-1.69	36-43	1.73	44	4.13	105	2.50	64
5.2	132	8	2.09-2.29	53-58	2.00	51	5.33	135	3.10	79
6.5	165	10	2.78-2.94	71-75	2.16	55	6.63	168	3.75	95
7.7	196	12	3.41-3.54	87-90	2.45	62	7.83	199	4.35	110
10.3	262	16	4.74-4.84	120-123	2.84	72	10.43	265	5.65	144
SERIES 800 NUB TOP, FLUSH GRID NUB TOP, SEAMFREE™ OPEN HINGE NUB TOP										
4.0	102	6	1.42-1.69	36-43	1.73	44	4.10	104	2.48	63
5.2	132	8	2.10-2.30	53-58	1.98	50	5.33	135	3.09	78
6.5	165	10	2.77-2.92	70-74	2.18	55	6.57	167	3.71	94
7.7	196	12	3.42-3.55	87-90	2.43	62	7.83	199	4.34	110
10.3	262	16	4.72-4.81	120-122	2.88	73	10.35	263	5.60	142
SERIES 800 CONE TOP, OPEN HINGE CONE TOP, SEAMFREE™ OPEN HINGE CONE TOP										
4.0	102	6	1.42-1.69	36-43	1.73	44	4.13	105	2.50	64
5.2	132	8	2.10-2.30	53-58	1.98	50	5.35	136	3.11	79
6.5	165	10	2.77-2.92	70-74	2.18	55	6.60	168	3.74	95
7.7	196	12	3.42-3.55	87-90	2.43	62	7.85	199	4.36	111
10.3	262	16	4.72-4.81	120-122	2.88	73	10.38	264	5.63	143
SERIES 800 ROLLER TOP										
4.0	102	6	1.42-1.69	36-43	1.73	44	4.44	113	2.81	71
5.2	132	8	2.10-2.30	53-58	1.98	50	5.66	144	3.43	87
6.5	165	10	2.77-2.92	70-74	2.18	55	6.91	176	4.05	103

Sprocket Description		A		B		C		E		
Pitch Diameter		No. Teeth	Range (Bottom to Top)		in.	mm	in.	mm	in.	mm
in.	mm		in.	mm						
7.7	196	12	3.42-3.55	87-90	2.43	62	8.17	207	4.68	119
10.3	262	16	4.72-4.81	120-122	2.88	73	10.69	272	5.94	151
SERIES 800 RAISED RIB										
4.0	102	6	1.42-1.69	36-43	1.73	44	4.28	109	2.65	67
5.2	132	8	2.09-2.29	53-58	2.00	51	5.48	139	3.25	83
6.5	165	10	2.78-2.94	71-75	2.16	55	6.78	172	3.90	99
7.7	196	12	3.41-3.54	87-90	2.45	62	7.98	203	4.50	114
10.3	262	16	4.74-4.84	120-123	2.84	72	10.58	269	5.80	147
SERIES 800 ROUND FRICTION TOP										
4.0	102	6	1.42-1.69	36-43	1.74	44	4.16	106	2.53	64
5.2	132	8	2.09-2.29	53-58	2.00	51	5.36	136	3.13	80
6.5	165	10	2.78-2.94	71-75	2.17	55	6.66	169	3.78	96
7.7	196	12	3.40-3.54	86-90	2.45	62	7.86	200	4.38	111
10.3	262	16	4.74-4.84	120-123	2.84	72	10.46	266	5.68	144

Dead Plate Gap

Where there is a transfer point from a belt without finger transfer plates to a dead plate, there should be a gap between the surfaces to allow for the chordal action of the belt. As the belt engages its sprockets, chordal action causes the modules to move past a *fixed* point (the tip of the dead plate) with *varying* clearances. The table below shows the minimum amount of gap which occurs at the “low point” of the modules if the tip of the dead plate just comes in contact with the “high point” as the modules pass.

In some installations it may be desirable to keep the tip of the dead plate in contact with the belt, rather than allow a gap to occur. This can be done by hinging the mounting bracket for the dead plate. This allows the dead plate to move as the modules pass, but results in a small oscillating motion which may present tipping problems for sensitive containers or products.

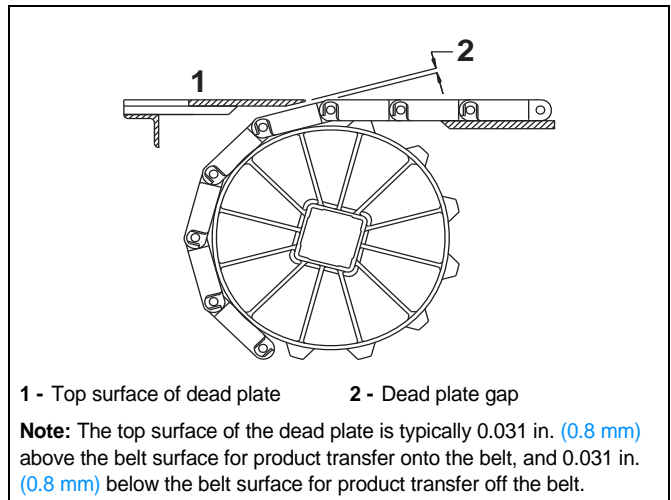

Sprocket Description			Gap	
Pitch Diameter		No. Teeth	in.	mm
in.	mm			
4.0	102	6	0.268	6.8
5.2	132	8	0.200	5.1
6.5	165	10	0.158	4.0
7.7	196	12	0.132	3.4
10.3	262	16	0.098	2.5

SeamFree™ Minimum Hinge Flat Top

	in	mm
Pitch	2.00	50.8
Minimum Width	6	152
Width Increments	1.00	25.4
Opening Size (approximate)	-	-
Open Area	0%	
Hinge Style	Open	
Drive Method	Center-driven	

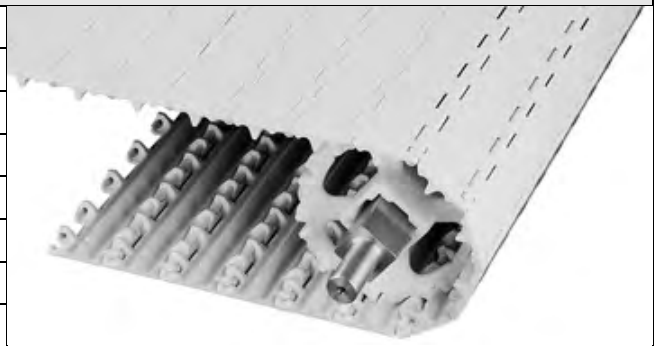

Product Notes

- **Contact Intralox for precise belt measurements and stock status before designing equipment or ordering a belt.**
- Smooth, closed upper surface with fully flush edges.
- Uses headed rods.
- Cam-link designed hinges - expose more hinge and rod area as the belt goes around the sprocket. This exclusive Intralox feature allows unsurpassed cleaning access to this area.
- Fully sculpted and radiused corners - no pockets or sharp corners to catch and hold debris.
- Like Series 1600 and Series 1800, the drive bar on the underside of Series 850 SeamFree™ Minimum Hinge Flat Top channels water and debris to the outside of the belt for easier, faster cleanup. The drive bar's effectiveness has been proven both in-house and in field tests.
- Designed for use with Series 800 Angled EZ Clean™ sprockets, but fully compatible with standard Series 800 EZ Clean sprockets.
- Belts over 36 in (914 mm) are built with multiple modules per row, but seams are minimized.



Additional Information

- See "Belt Selection Process" (page 5)
- See "Standard Belt Materials" (page 9)
- See "Special Application Belt Materials" (page 9)
- See "Friction Factors" (page 13)

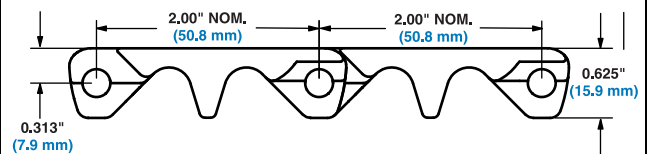

Belt Data

Belt Material	Standard Rod Material Ø 0.24 in (6.1 mm)	BS Belt Strength		Temperature Range (continuous)		W Belt Weight	
		lb/ft	kg/m	°F	°C	lb/ft ²	kg/m ²
Acetal	Acetal	275	409	-50 to 200	-46 to 93	2.19	10.68
Acetal	Polypropylene	250	372	34 to 200	1 to 93	2.13	10.41
Acetal	Polyethylene	150	223	-50 to 150	-46 to 66	2.13	10.40
Detectable Acetal	Acetal	275	409	-50 to 200	-46 to 93	2.23	10.89
Polyethylene	Acetal	200	298	-50 to 150	-46 to 66	1.50	7.32
Polyethylene	Polyethylene	150	223	-50 to 150	-46 to 66	1.44	7.05
Polypropylene	Polypropylene	200	298	34 to 220	1 to 104	1.40	6.83

SeamFree™ Minimum Hinge Nub Top™

	in	mm
Pitch	2.00	50.8
Minimum Width	6	152
Width Increments	1.00	25.4
Opening Sizes (approx.)	-	-
Open Area	0%	
Hinge Style	Open	
Drive Method	Center-Driven	



Product Notes

- **Contact Intralox for precise belt measurements and stock status before designing equipment or ordering a belt.**
- Nub height is 0.100 in (2.5 mm).
- Nub spacing is 0.333 in (8.5 mm).
- Standard nub indent is 1.3 in (33 mm).
- Closed upper surface with fully flush edges.
- Uses headed rods.
- Cam-link designed hinges expose more hinge and rod area as the belt goes around the sprocket. This exclusive Intralox feature allows unsurpassed cleaning access to this area.
- Fully sculpted and radiused corners - no pockets or sharp corners to catch and hold debris.
- Like Series 800 and Series 1800, the drive bar on the underside of Series 850 SeamFree Minimum Hinge Nub Top channels water and debris to the outside of the belt for easier, faster cleanup. The drive bar's effectiveness has been proven both in-house and in field tests.
- Not recommended for back-up conditions. If values are required, contact Intralox Sales Engineering.

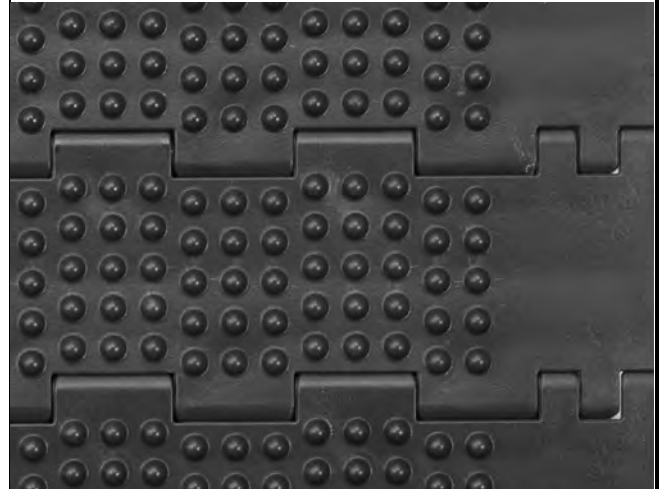

Additional Information

- See "Belt Selection Process" (page 5)
- See "Standard Belt Materials" (page 9)
- See "Special Application Belt Materials" (page 9)
- See "Friction Factors" (page 13)

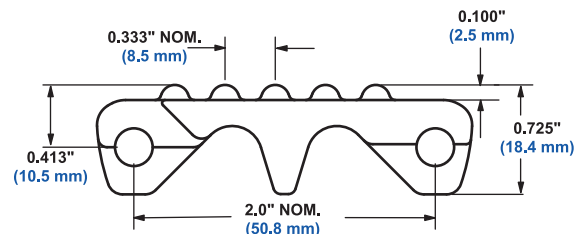

Belt Data

Belt Material	Standard Rod Material Ø 0.24 in (6.1 mm)	BS Belt Strength		Temperature Range (continuous)		W Belt Weight	
		lb/ft	kg/m	°F	°C	lb/ft ²	kg/m ²
Acetal	Acetal	275	409	-50 to 200	-46 to 93	2.39	11.67
Acetal	Polypropylene	250	372	34 to 200	1 to 93	2.33	11.38
Acetal	Polyethylene	150	223	-50 to 150	-46 to 66	2.33	11.38
Polyethylene	Acetal	200	298	-50 to 150	-46 to 66	1.64	8.01
Polyethylene	Polypropylene	150	223	-50 to 150	-46 to 66	1.58	7.71
Polypropylene	Polypropylene	200	298	34 to 220	1 to 104	1.53	7.47

SeamFree™ Minimum Hinge Cone Top™

	in	mm
Pitch	2.00	50.8
Minimum Width	6	152
Maximum Width	36	914
Width Increments	1.00	25.4
Opening Sizes (approx.)	-	-
Open Area	0%	
Hinge Style	Open	
Drive Method	Center-Driven	

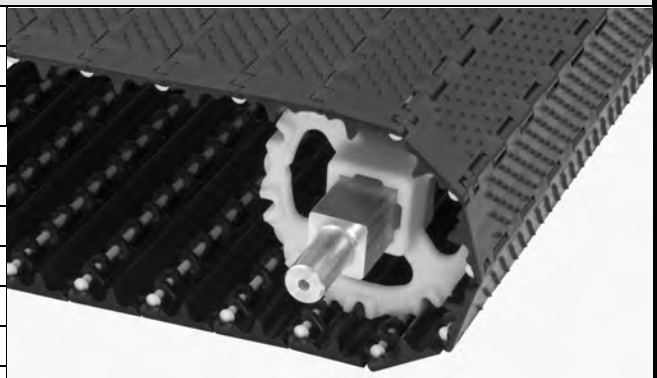

Product Notes

- **Contact Intralox for precise belt measurements and stock status before designing equipment or ordering a belt.**
- Cone height is 0.125 in (3.2 mm).
- Cone spacing is 0.268 in (6.88 mm).
- Standard cone indent is 1.3 in (33 mm).
- Closed upper surface with fully flush edges.
- Uses headed rods.
- Cam-link designed hinges expose more hinge and rod area as the belt goes around the sprocket. This exclusive Intralox feature allows unsurpassed cleaning access to this area.
- Fully sculpted and radiused corners - no pockets or sharp corners to catch and hold debris.
- Like Series 800 and Series 1800, the drive bar on the underside of Series 850 SeamFree Minimum Hinge Cone Top channels water and debris to the outside of the belt for easier, faster cleanup. The drive bar's effectiveness has been proven both in-house and in field tests.
- Not recommended for back-up conditions. If values are required, contact Intralox Sales Engineering.

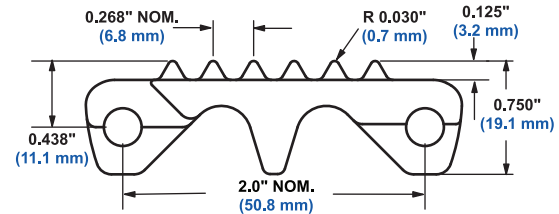
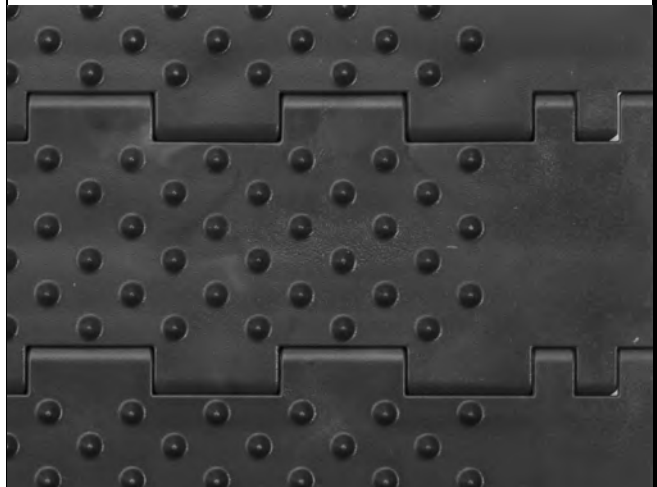

Additional Information

- See "Belt Selection Process" (page 5)
- See "Standard Belt Materials" (page 9)
- See "Special Application Belt Materials" (page 9)
- See "Friction Factors" (page 13)

Belt Data

Belt Material	Standard Rod Material Ø 0.24 in (6.1 mm)	BS		Temperature Range (continuous)		W	
		Belt Strength		°F	°C	Belt Weight	
		lb/ft	kg/m			lb/ft²	kg/m²
Acetal	Acetal	275	409	-50 to 200	-46 to 93	2.28	11.13
Acetal	Polypropylene	250	372	34 to 200	1 to 93	2.22	10.84
Acetal	Polyethylene	150	223	-50 to 150	-46 to 66	2.22	10.84
Polyethylene	Acetal	200	298	-50 to 150	-46 to 66	1.56	7.62
Polyethylene	Polypropylene	150	223	-50 to 150	-46 to 66	1.50	7.32
Polypropylene	Polypropylene	200	298	34 to 220	1 to 104	1.47	7.18

Sprocket and Support Quantity Reference				
Belt Width Range ^a		Minimum Number of Sprockets Per Shaft ^b	Wearstrips	
in.	mm		Carryway	Returnway
2	51	1	2	2
4	102	1	2	2
6	152	2	2	2
8	203	2	2	2
10	254	2	3	2
12	305	3	3	2
14	356	3	3	3
16	406	3	3	3
18	457	3	3	3
20	508	5	4	3
24	610	5	4	3
30	762	5	5	4
32	813	7	5	4
36	914	7	5	4
42	1067	7	6	5
48	1219	9	7	5
54	1372	9	7	6
60	1524	11	8	6
72	1829	13	9	7
84	2134	15	11	8
96	2438	17	12	9
120	3048	21	15	11
144	3658	25	17	13
For Other Widths, Use Odd Number of Sprockets ^c at Maximum 6 in. (152 mm) \varnothing Spacing			Maximum 9 in. (229 mm) \varnothing Spacing	Maximum 12 in. (305 mm) \varnothing Spacing

- If your belt width exceeds a number listed in the table, please refer to the sprocket and support material minimums for the next larger width range listed. Belts are available in 1.0 in. (25.4 mm) increments beginning with minimum width of 2 in. (51 mm). **If the actual width is critical, consult Customer Service**
- These are the minimum number of sprockets. Additional sprockets may be required for heavily loaded applications. Polyurethane sprockets require a maximum 4 in. (102 mm) centerline spacing.
- The center sprocket should be locked down. With only two sprockets, fix the sprocket on the drive journal side only. See Retainer Rings/Center Sprocket Offset chart on page 410 for lock down location.

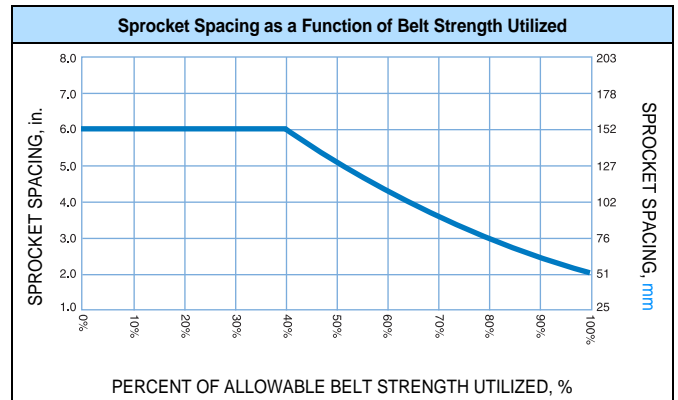
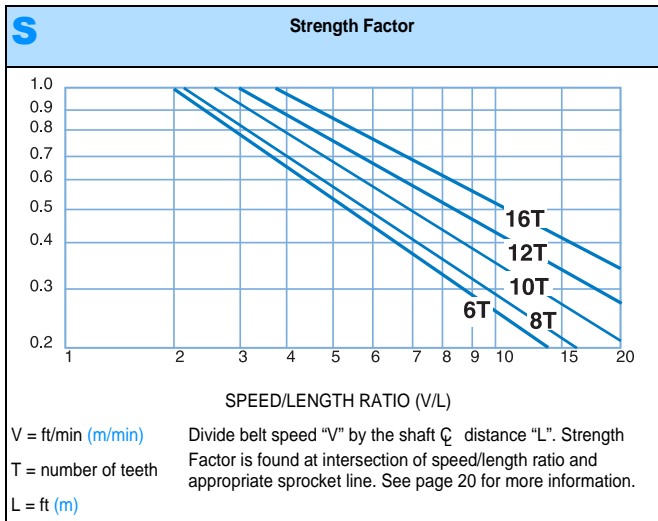

Angled EZ Clean Sprocket^a										
No. of Teeth (Chordal Action)	Nom. Pitch Dia. in.	Nom. Pitch Dia. mm	Nom. Outer Dia. in.	Nom. Outer Dia. mm	Nom. Hub Width in.	Nom. Hub Width mm	Available Bore Sizes			
							U.S. Sizes		Metric Sizes	
							Round in.	Square in.	Round mm	Square mm
6 (13.40%)	4.0	102	3.8	97	2.0	50.8		1.5		40
8 (7.61%)	5.2	132	5.0	127	2.0	50.8		1.5		40
10 (4.89%)	6.5	165	6.2	157	2.0	50.8		1.5		40
12 (3.41%)	7.7	196	7.5	191	2.0	50.8		1.5		40
16 (1.92%)	10.3	262	10.1	257	1.5	38		1.5		40
								2.5		60

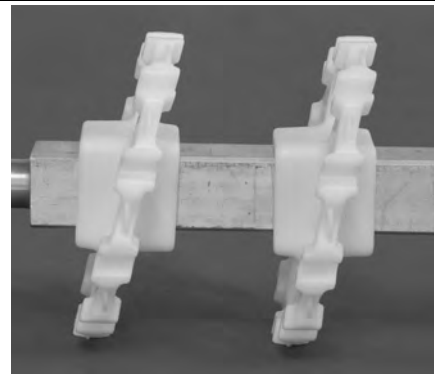

a. Contact Customer Service for lead times. Angled EZ Clean Sprockets can not be used with Series 800 Mesh Top

Streamline Flights		
Available Flight Height		Available Materials
in.	mm	
4	102	
		Polypropylene, Acetal
<p>Note: Flights are available in the SeamFree™ design at 12 in. (304 mm) wide; flighted belts greater than 12 in. (304 mm) wide are available with seams minimized.</p> <p>Note: Flights can be cut down to custom heights with a minimum height of 0.25 in (13 mm).</p> <p>Note: Each flight rises out of the center of its supporting module, molded as an integral part. No fasteners are required.</p> <p>Note: Flat Top flight is smooth (Streamline) on both sides.</p> <p>Note: Molded-in, 1.3 in. (33 mm) indent from each edge.</p>		

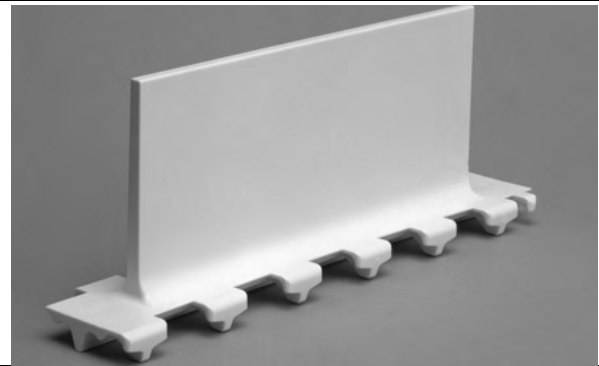

Conveyor Frame Dimensions

Regardless of type or configuration, all conveyors using Intralox belts have some basic dimensional requirements. Specifically, dimensions “A”, “B”, “C” and “E” listed below should be implemented in any design.

For general applications and applications where end transfer of tip-sensitive product is not critical, use the “A” dimension at the bottom of the range.

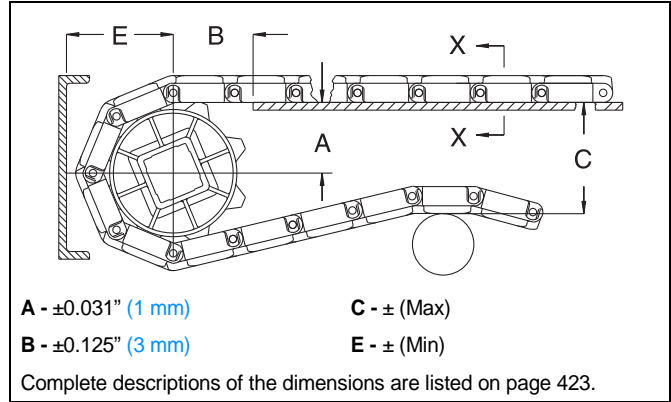

Sprocket Description		A		B		C		E		
Pitch Diameter		No. Teeth	Range (Bottom to Top)		in.	mm	in.	mm	in.	mm
in.	mm		in.	mm						
SERIES 850 SEAMFREE™ MINIMUM HINGE FLAT TOP										
4.0	102	6	1.42-1.69	36-43	1.73	44	4.00	102	2.38	60
5.2	132	8	2.09-2.29	53-58	2.00	51	5.20	132	2.98	76
6.5	165	10	2.78-2.94	71-75	2.16	55	6.50	165	3.63	92
7.7	196	12	3.41-3.54	87-90	2.45	62	7.70	196	4.23	107
10.3	262	16	4.74-4.84	120-123	2.84	72	10.30	262	5.53	140
SERIES 850 SEAMFREE™ MINIMUM HINGE NUB TOP										
4.0	102	6	1.42-1.69	36-43	1.73	44	4.10	104	2.48	63
5.2	132	8	2.10-2.30	53-58	1.98	50	5.33	135	3.09	78
6.5	165	10	2.77-2.92	70-74	2.18	55	6.57	167	3.71	94
7.7	196	12	3.42-3.55	87-90	2.43	62	7.83	199	4.34	110
10.3	262	16	4.72-4.81	120-122	2.88	73	10.35	263	5.60	142
SERIES 850SEAMFREE™ MINIMUM HINGE CONE TOP										
4.0	102	6	1.42-1.69	36-43	1.73	44	4.13	105	2.50	64
5.2	132	8	2.10-2.30	53-58	1.98	50	5.35	136	3.11	79
6.5	165	10	2.77-2.92	70-74	2.18	55	6.60	168	3.74	95
7.7	196	12	3.42-3.55	87-90	2.43	62	7.85	199	4.36	111
10.3	262	16	4.72-4.81	120-122	2.88	73	10.38	264	5.63	143

Dead Plate Gap

Where there is a transfer point from a belt without finger transfer plates to a dead plate, there should be a gap between the surfaces to allow for the chordal action of the belt. As the belt engages its sprockets, chordal action causes the modules to move past a *fixed* point (the tip of the dead plate) with *varying* clearances. The table below shows the minimum amount of gap which occurs at the “low point” of the modules if the tip of the dead plate just comes in contact with the “high point” as the modules pass.

In some installations it may be desirable to keep the tip of the dead plate in contact with the belt, rather than allow a gap to occur. This can be done by hinging the mounting bracket for the dead plate. This allows the dead plate to move as the modules pass, but results in a small oscillating motion which may present tippage problems for sensitive containers or products.

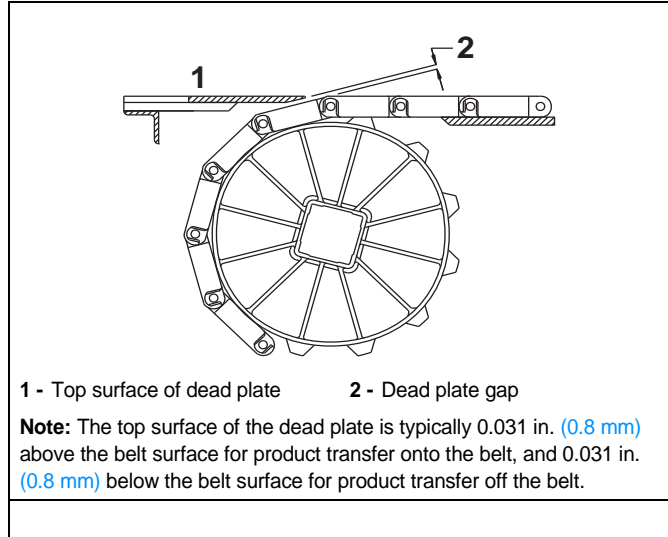

Sprocket Description			Gap	
Pitch Diameter		No. Teeth	in.	mm
in.	mm			
5.2	132	8	0.200	5.1
6.5	165	10	0.158	4.0
7.7	196	12	0.132	3.4

Medium Slot		
	in	mm
Pitch	2.0	50.8
Minimum Width	6.0	152
Width Increments	0.66	17
Slot Size, Linear	0.08 x 0.40	2.0 x 10.2
Slot Size, Transverse	0.09 x 0.24	2.3 x 6.1
Open Area	20%	
Hinge Style	Open	
Drive Method	Center-Driven	
Product Notes		
<ul style="list-style-type: none"> • Contact Intralox for precise belt measurements and stock status before designing equipment or ordering a belt. • Proven Enduralox™ polypropylene material increases resistance to chemical and temperature cycling • Proven drive system requires less back tension and is less sensitive to belt elongation • Barn door style rod retention system simplifies installation and routine maintenance. • Uses headless rods. • Molded-in sideguards, flush with belt edges, provides maximum utilization of belt surface and robust design reduces contamination risks • For belts with molded-in sideguards, provide a minimum backbend radius of 7.0 in (180 mm). 		
Additional Information		
<ul style="list-style-type: none"> • See "Belt Selection Process" (page 5) • See "Standard Belt Materials" (page 9) • See "Special Application Belt Materials" (page 9) 		

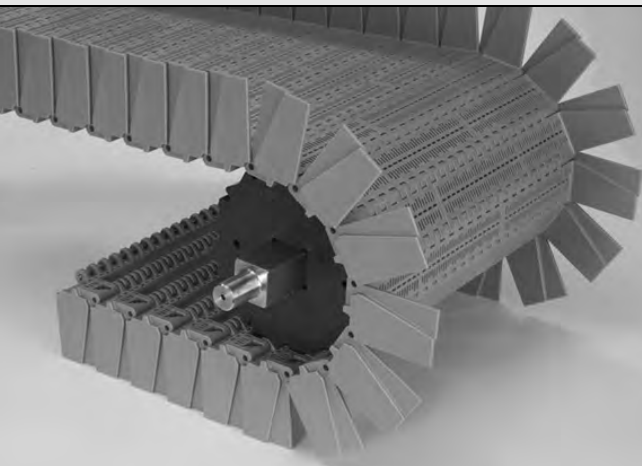
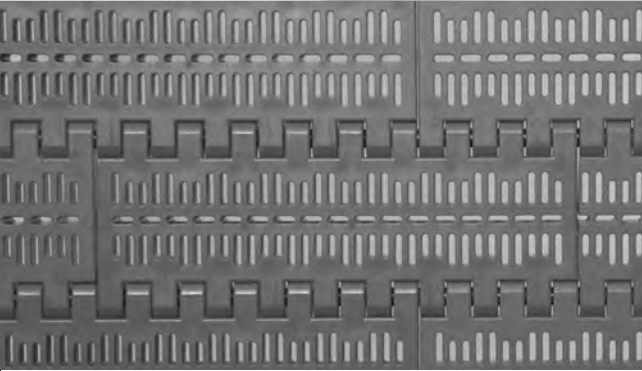
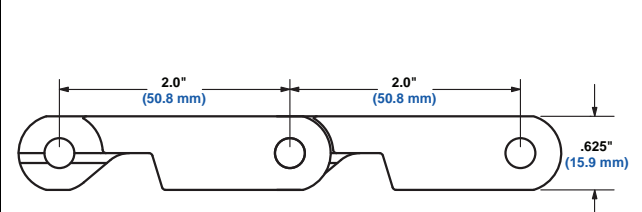
Belt Data							
Belt Material	Standard Rod Material Ø 0.24 in. (6.1 mm)	BS Belt Strength		Temperature Range (continuous)		W Belt Weight	
		lb/ft	kg/m	°F	°C	lb/ft ²	kg/m ²
Enduralox Polypropylene	303/304 Stainless Steel	1500	2230	34 to 220	1 to 104	2.4	11.7

Medium Slot SSL

	in	mm
Pitch	2.0	50.8
Minimum Width	11.3	288
Width Increments	0.66	17
Slot Size, Linear	0.08 x 0.40	2.0 x 10.2
Slot Size, Transverse	0.09 x 0.24	2.3 x 6.1
Open Area	26%	
Hinge Style	Open	
Drive Method	Center-Driven	

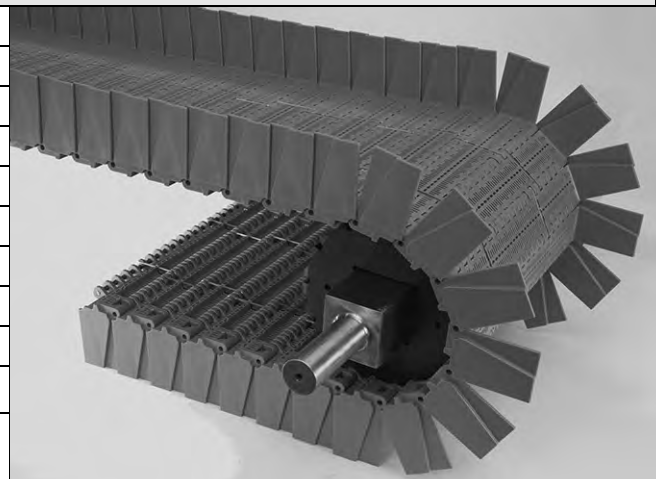

Product Notes

- **Contact Intralox for precise belt measurements and stock status before designing equipment or ordering a belt.**
- Proven Enduralox™ polypropylene material increases resistance to chemical and temperature cycling.
- Stainless Steel Links (SSL) are integrated into the belt design to manage high loads and thermal expansion associated with temperature variations.
- Proven drive system requires less back tension and is less sensitive to belt elongation.
- Barn door style rod retention system simplifies installation and routine maintenance.
- Uses headless rods.
- Molded-in sideguards (MISG), flush with belt edges, provide maximum utilization of belt surface and robust design reduces contamination risks.
- For belts with molded-in sideguards (MISG), provide a minimum backbend radius of 7 in (180 mm).

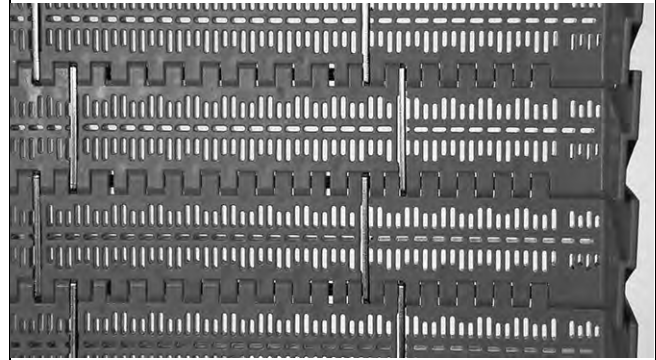

Additional Information

- See "Belt Selection Process" (page 5)
- See "Standard Belt Materials" (page 9)
- See "Special Application Belt Materials" (page 9)

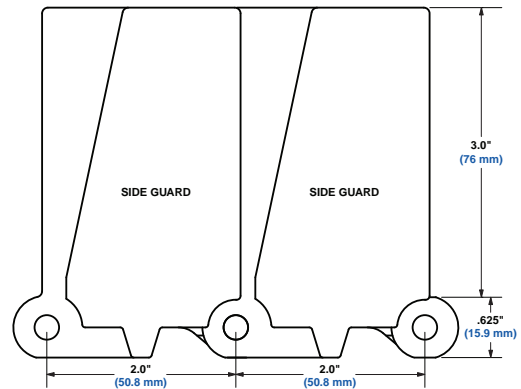

Belt Data

Belt Material	Standard Rod Material Ø 0.24 in (6.1 mm)	BS Belt Strength		Temperature Range (continuous)		W Belt Weight	
		lb/ft	kg/m	°F	°C	lb/ft ²	kg/m ²
Enduralox Polypropylene	Wear-resistant Stainless Steel	2000	3000	34 to 212	1 to 100	2.6	12.7

Large Slot SSL		
	in	mm
Pitch	2.0	50.8
Minimum Width	16.0	406
Width Increments	0.66	17
Slot Size, Linear	0.16 x 0.39	4.1 x 9.9
Slot Size, Transverse	0.12 x 0.50	3.0 x 12.7
Open Area	22%	
Hinge Style	Open	
Drive Method	Center-Driven	
Product Notes		
<ul style="list-style-type: none"> • Contact Intralox for precise belt measurements and stock status before designing equipment or ordering a belt. • Proven Enduralox™ polypropylene material increases resistance to chemical and temperature cycling • Stainless Steel Links (SSL) are integrated into the belt design to manage high loads and thermal expansion associated with temperature variations. • Proven drive system requires less back tension and is less sensitive to belt elongation • Barn door style rod retention system simplifies installation and routine maintenance. • Uses headless rods. • Molded-in sideguards (MISG), flush with belt edges, provides maximum utilization of belt surface and robust design reduces contamination risks • For belts with Molded-in sideguards (MISG), expect a minimum backbend radius of 7 in (180 mm) 		
Additional Information		
<ul style="list-style-type: none"> • See “Belt Selection Process” (page 5) • See “Standard Belt Materials” (page 9) • See “Special Application Belt Materials” (page 9) 		

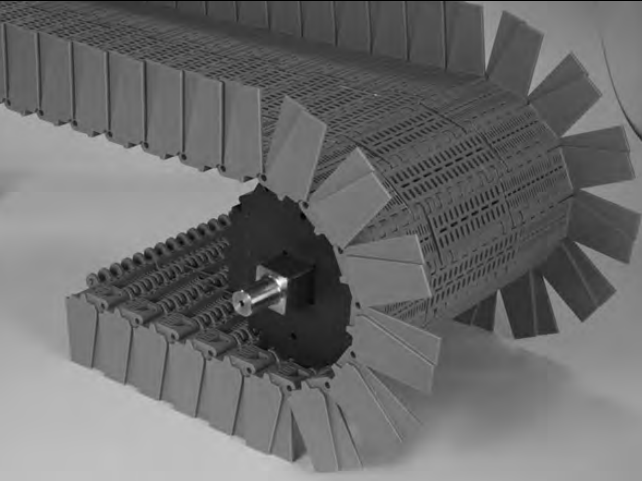
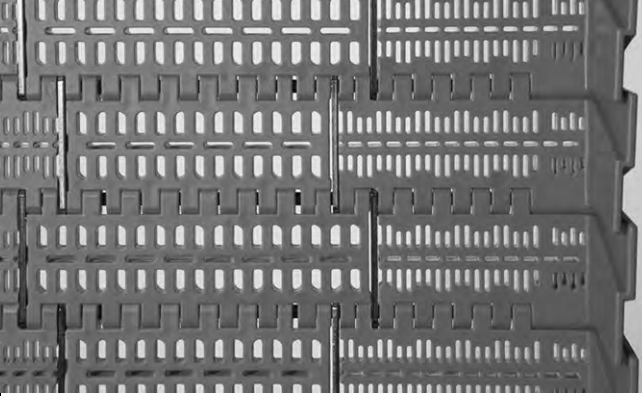
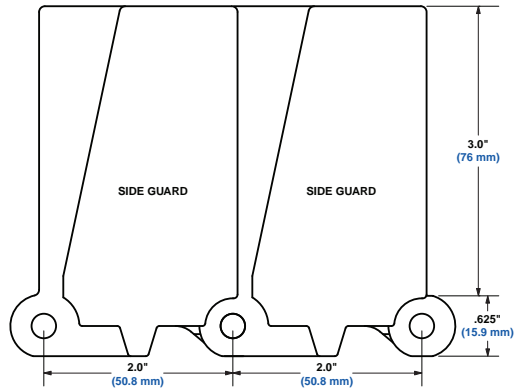
Belt Data							
Belt Material	Standard Rod Material Ø 0.24 in (6.1 mm)	BS	Belt Strength	Temperature Range (continuous)		W	Belt Weight
		lb/ft	kg/m	°F	°C	lb/ft ²	kg/m ²
Enduralox Polypropylene	Wear-resistant Stainless Steel	2000	3000	34 to 212	1 to 100	2.6	12.7

Round Hole Enhanced		
	in.	mm
Pitch	1.99	50.5
Minimum Width	6	152.4
Width Increments	0.66	16.8
Opening Size (approximate)	-	-
Open Area	20%	
Hinge Style	Open	
Drive Method	Center-driven	
Product Notes		
<ul style="list-style-type: none"> Contact Intralox for precise belt measurements and stock status before designing equipment or ordering a belt. Enhanced hole pattern and design of S800 Perforated Flat Top. Improved hole pattern and more open hinge design allows for better air flow and drainage. Smooth upper surface with fully flush edges. Uses a headless rod retention feature. Minimum sprocket indent is 1.25 in (32 mm) to the edge of the sprocket. 		
Additional Information		
<ul style="list-style-type: none"> See "Belt Selection Process" (page 5) See "Standard Belt Materials" (page 9) See "Special Application Belt Materials" (page 9) 		



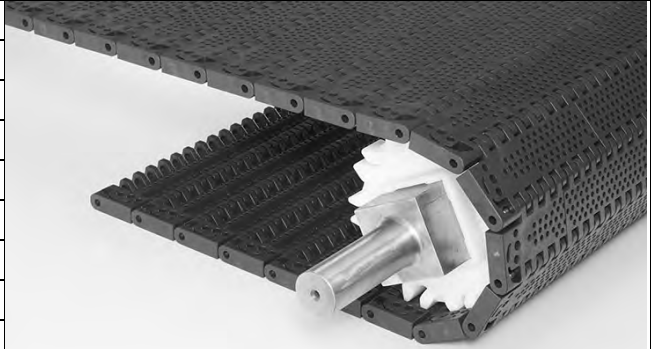
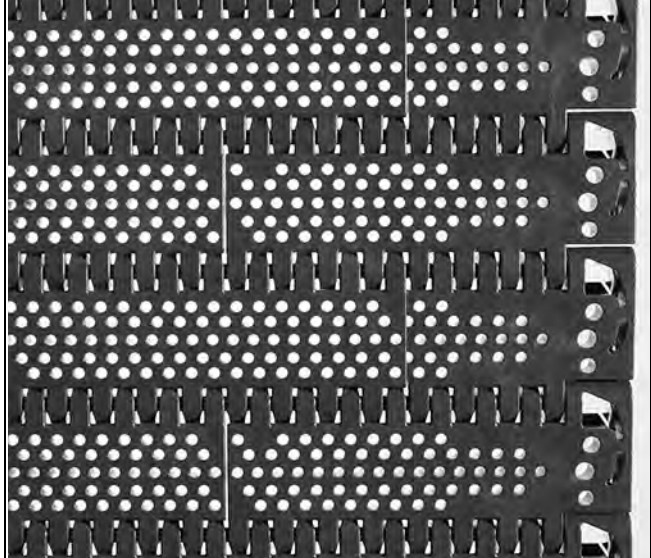

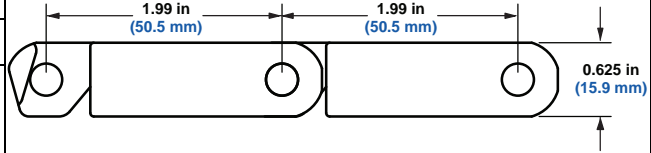

Belt Data									
Belt Material	Standard Rod Material Ø 0.24 in. (6.1 mm)	BS		Belt Strength		Temperature Range (continuous)		W	
		lb/ft	kg/m	°F	°C	lb/ft ²	kg/m ²		
Acetal	304 Stainless Steel	1500	2200	-50 to 150	-46 to 66	3.10	15.14		

Sprocket and Support Quantity Reference							
Medium Slot, Round Hole Enhanced			Medium Slot SSL, Large Slot SSL			Wearstrips Medium Slot and Large Slot SSL	
Belt Width Range^a		Minimum Number of Sprockets Per Shaft^b	Belt Width Range^a		Maximum Number of Sprockets Per Shaft^b	Carryway	Returnway
in	mm		in	mm			
6	152	2	22.6-28.0	575-711	6	2	2
8	203	2	28.6-30.6	727-778	7	2	2
10	254	2	31.3-35.3	795-897	8	3	2
12	305	3	36.0-40.6	914-1032	9	3	2
14	356	3	41.3-46.0	1049-1167	10	3	3
16	406	3	46.6-48.0	1184-1218	11	3	3
18	457	3	48.6-52.6	1235-1336	12	3	3
20	508	5	53.3-58.6	1353-1489	13	4	3
24	610	5	59.3-64.6	1506-1641	14	4	3
30	762	5	65.3-66.6	1658-1692	15	5	4
32	813	7	67.3-72.6	1709-1844	16	5	4
36	914	7	73.3-79.9	1861-2030	17	5	4
42	1067	7	80.6-84.6	2047-2148	18	6	5
48	1219	9	85.3-87.9	2165-2233	19	7	5
54	1372	9	88.6-91.9	2250-2335	20	7	6
60	1524	11	92.6-95.2	2351-2419	21	8	6
72	1829	13	95.9-98.6	2436-2504	22	9	7
84	2134	15	99.2-103.2	2521-2622	23	11	8
96	2438	17	103.9-109.2	2639-2774	24	12	9
120	3048	21	109.9-118.6	2791-3011	25	15	11
144	3658	25	119.2-119.9	3028-3045	26	17	13
For Other Widths, Use Odd Number of Sprockets at Maximum 6 in. (152 mm) \varnothing Spacing			To avoid sprockets to interfere with Stainless Steel links please refer to our sprocket installation instruction or belt maintenance and installation guide line.			Maximum 12 in. (305 mm) \varnothing Spacing	

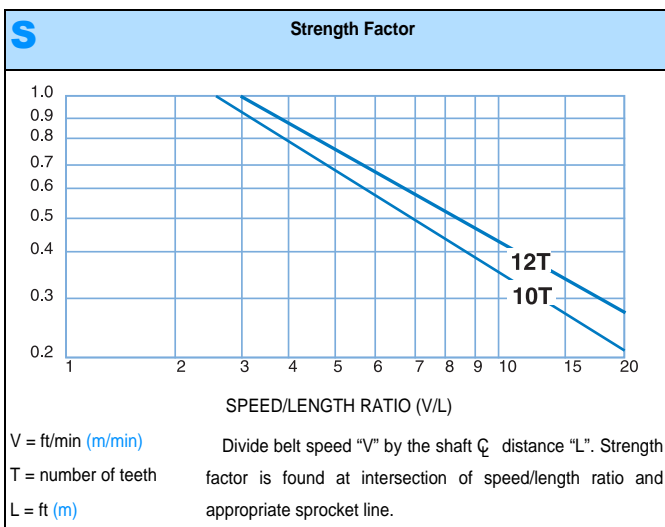
- a. If your belt width exceeds a number listed in the table, please refer to the sprocket and support material minimums for the next larger width range listed. Belts are available in 0.66 in. (16.8 mm) increments beginning with minimum width of 2 in. (51 mm). **If the actual width is critical, consult Customer Service.**
- b. All sprockets are to be locked in place on the shaft. Use appropriate locking collars to restrict axial movement.



Nylon Sprocket

No. of Teeth (Chordal Action)	Nom. Pitch Dia. in.	Nom. Pitch Dia. mm	Nom. Outer Dia. in.	Nom. Outer Dia. mm	Nom. Hub Width in.	Nom. Hub Width mm	Available Bore Sizes			
							U.S. Sizes		Metric Sizes	
							Round in.	Square in.	Round mm	Square mm
10 (4.70%)	6.5	165	6.2	157	1.0	25	Custom Order	Custom Order	50, 60, 70, 80, 90 and 100	Custom Order
12 (3.29%)	7.78	196	7.5	191	1.0	25	Custom Order	Custom Order	50, 60, 70, 80, 90 and 100	50, 60, 70, 80, 90



Note: Imperial key sizes on round bore sprockets conform to ANSI standard B17.1-1967 (R1989) and metric key sizes conform to DIN standard 6885.

Note: All sprockets are to be locked in place on shaft.

Buildup Resistant Acetal Sprocket^a

No. of Teeth (Chordal Action)	Nom. Pitch Dia. in.	Nom. Pitch Dia. mm	Nom. Outer Dia. in.	Nom. Outer Dia. mm	Nom. Hub Width in.	Nom. Hub Width mm	Available Bore Sizes			
							U.S. Sizes		Metric Sizes	
							Round in.	Square in.	Round mm	Square mm
10 (4.89%)	6.5	165	6.2	157	1.5	38		2.5		60 ^b



Note: Designed to work with the Round Hole Enhanced belt in Freezer Tunnel applications. Contact Intralox Customer Service for other applications.

Note: All sprockets are to be locked in place on shaft.

- a. Contact Customer Service for lead times.
- b. Available as standard 60 mm square bore or available with 4 retention notches.

Universal Sideguards

Available Height		Available Materials
in.	mm	
2	51	Blue Polypropylene
3	76	Blue Polypropylene
4	102	Blue Polypropylene
6	152	Blue Polypropylene

Note: Part of Intralox's EZ Clean product line.
Note: There is a minimum indent of 2.0 in. (51 mm) at edges.
Note: The minimum back bend radius is 4.5 in. (115 mm).
Note: Standard sideguard orientation is angled inward toward the product (product friendly). If needed, sideguards can be angled outward toward the conveyor.

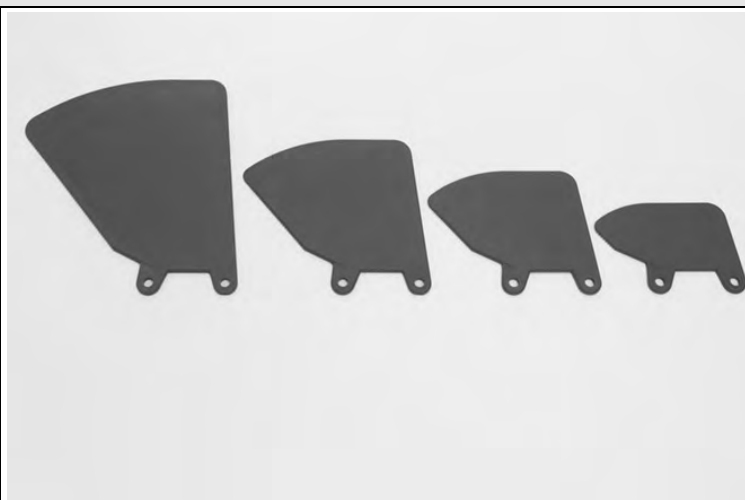

Conveyor Frame Dimensions

Regardless of type or configuration, all conveyors using Intralox belts have some basic dimensional requirements. Specifically, dimensions “A”, “B”, “C” and “E” listed below should be implemented in any design.

For general applications and applications where end transfer of tip-sensitive product is not critical, use the “A” dimension at the bottom of the range.

Conveyor frame dimensions are established using the top of the roller as the top of the belt and the bottom of the module as the bottom of the belt. “B” dimension is based on a 0.5 in. (12.7 mm) thick carryway.

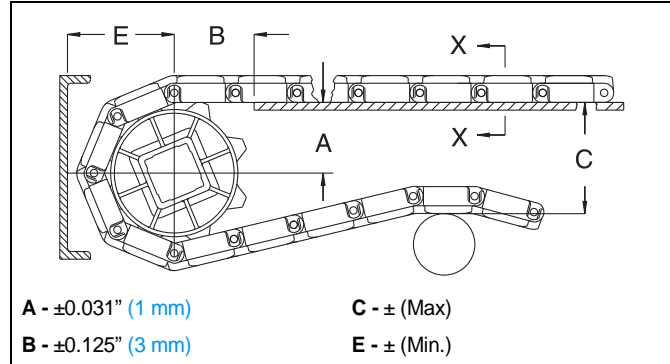

Sprocket Description			A		B		C		E	
Pitch Diameter		No. Teeth	Range (Bottom to Top)		in.	mm	in.	mm	in.	mm
in.	mm		in.	mm						
6.5	165	10	2.77-2.925	70-74	3.00	76	6.5	165	3.61	92
7.7	196	12	3.42-3.55	87-90	3.00	76	7.9	201	4.24	108

Dead Plate Gap

Where there is a transfer point from a belt without finger transfer plates to a dead plate, there should be a gap between the surfaces to allow for the chordal action of the belt. As the belt engages its sprockets, chordal action causes the modules to move past a *fixed* point (the tip of the dead plate) with *varying* clearances. The table below shows the minimum amount of gap which occurs at the “low point” of the modules if the tip of the dead plate just comes in contact with the “high point” as the modules pass.

In some installations it may be desirable to keep the tip of the dead plate in contact with the belt, rather than allow a gap to occur. This can be done by hinging the mounting bracket for the dead plate. This allows the dead plate to move as the modules pass, but results in a small oscillating motion which may present tippage problems for sensitive containers or products.

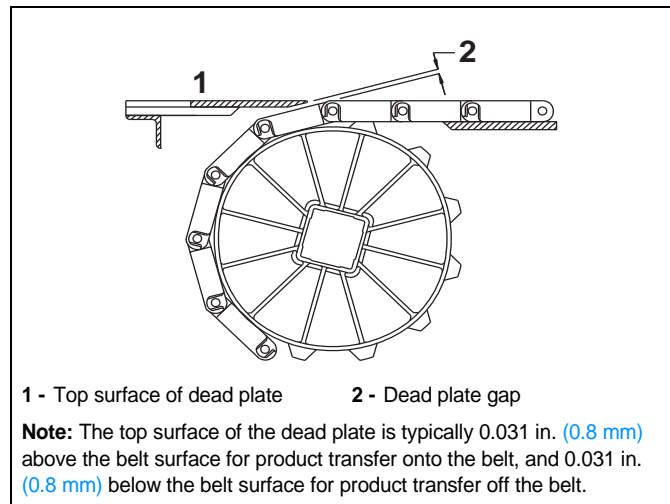

Sprocket Description			Gap	
Pitch Diameter		No. Teeth	in.	mm
in.	mm			
6.5	165	10	0.158	4.0
7.7	196	12	0.132	3.4

Open Grid		
	in	mm
Pitch	1.07	27.2
Minimum Width	2	51
Width Increments	0.33	8.4
Opening Size (approximate)	0.24 × 0.28	6.1 × 7.1
Open Area	38%	
Hinge Style	Open	
Drive Method	Center-driven	
Product Notes		
<ul style="list-style-type: none"> • Contact Intralox for precise belt measurements and stock status before designing equipment or ordering a belt. • Low-profile transverse ridges 0.188 in (4.8 mm) high assist in moving product up inclines and down declines. • Uses headed rods. • Large, open area allows for excellent drainage. • Normal indent of the ridge is 0.25 in (6.4 mm). • Not recommended for back-up conditions. If friction values between product and belt are required, contact Intralox Sales Engineering. 		
Additional Information		
<ul style="list-style-type: none"> • See "Belt Selection Process" (page 5) • See "Standard Belt Materials" (page 9) • See "Special Application Belt Materials" (page 9) • See "Friction Factors" (page 13) 		

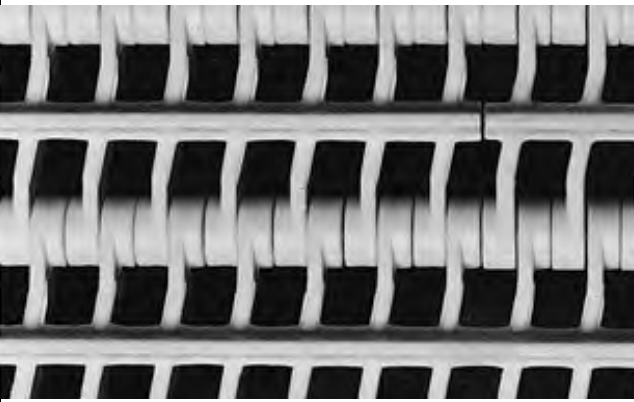
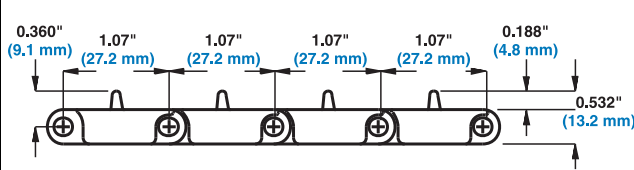



Belt Data							
Belt Material	Standard Rod Material Ø 0.18 in (4.6 mm)	BS Belt Strength		Temperature Range (continuous)		W Belt Weight	
		lb/ft	kg/m	°F	°C	lb/ft ²	kg/m ²
Polypropylene	Polypropylene	700	1040	34 to 220	1 to 104	0.81	3.95
Polyethylene	Polyethylene	350	520	-50 to 150	-46 to 66	0.84	4.09
Acetal	Polypropylene	1480	2200	34 to 200	1 to 93	1.26	6.14
Acetal ^a	Polyethylene	1000	1490	-50 to 70	-46 to 21	1.26	6.14

a. Polyethylene rods can be used in cold applications when impacts or sudden starts/stops occur. Please note lower rating.

Flush Grid

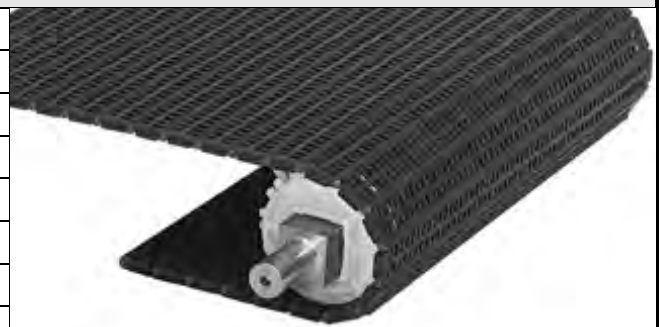
	in	mm
Pitch	1.07	27.2
Minimum Width	2	51
Width Increments	0.33	8.4
Opening Size (approximate)	0.24 × 0.28	6.1 × 7.1
Open Area	38%	
Hinge Style	Open	
Drive Method	Center-driven	



Product Notes

- **Contact Intralox for precise belt measurements and stock status before designing equipment or ordering a belt.**
- Open pattern with smooth upper surface, fully flush edges.
- Uses headed rods.
- Offers excellent lateral movement of containers.
- Flights and sideguards are available.
- HR nylon belts use short rodlets to hold the main hinge rod in place. The rodlets are made from the same material as the main rod.

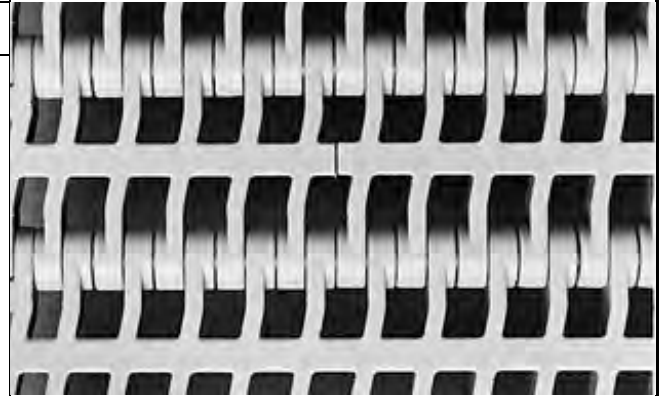

Additional Information

- See "Belt Selection Process" (page 5)
- See "Standard Belt Materials" (page 9)
- See "Special Application Belt Materials" (page 9)
- See "Friction Factors" (page 13)

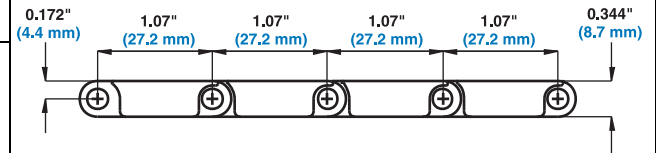

Belt Data

Belt Material	Standard Rod Material Ø 0.18 in (4.6 mm)	BS Belt Strength		Temperature Range (continuous)		W Belt Weight	
		lb/ft	kg/m	°F	°C	lb/ft ²	kg/m ²
Polypropylene	Polypropylene	700	1040	34 to 220	1 to 104	0.76	3.70
Enduralox™ Polypropylene	Polypropylene	700	1040	34 to 220	1 to 104	0.76	3.70
Polyethylene	Polyethylene	350	520	-50 to 150	-46 to 66	0.81	3.96
Acetal	Polypropylene	1480	2200	34 to 200	1 to 93	1.15	5.62
HSEC Acetal	Polypropylene	800	1190	34 to 200	1 to 93	1.15	5.62
Hi-Temp	Hi-Temp	1200	1786	70 to 400	21 to 204	1.08	5.27
FR-TPES	Polypropylene	750	1120	40 to 150	4 to 66	1.19	5.81
HR Nylon ^a	HR Nylon	1200	1790	-50 to 240	-46 to 116	1.10	5.40
HHR Nylon	HHR Nylon	1200	1790	-50 to 310	-46 to 154	1.10	5.40
Acetal ^b	Polyethylene	1000	1490	-50 to 70	-46 to 21	1.15	5.62

a. This product cannot be used for food contact articles that will come in contact with food containing alcohol.
 b. Polyethylene rods can be used in cold applications when impacts or sudden starts/stops occur. Please note lower rating.

Open Flush Grid		
	in	mm
Pitch	1.07	27.2
Minimum Width	10	254
Width Increments ^a	0.33	8.4
Minimum Opening Size (approx.)	0.17 x 0.29	4.3 x 7.4
Maximum Opening Size (approx.)	0.28 x 0.29	7.1 x 7.4
Open Area	43%	
Hinge Style	Open	
Drive Method	Center-driven	
Product Notes		
<ul style="list-style-type: none"> • Contact Intralox for precise belt measurements and stock status before designing equipment or ordering a belt. • Open pattern with a smooth upper surface and fully flush edges. • Flush edge is designed to accommodate special abrasion resistant nylon rod growth for belt widths 42" (1066 mm) or narrower. • Uses headless rods. • Flight accessories are available in HHR nylon material only. 		
Additional Information		
<ul style="list-style-type: none"> • See "Belt Selection Process" (page 5) • See "Standard Belt Materials" (page 9) • See "Special Application Belt Materials" (page 9) • See "Friction Factors" (page 13) 		

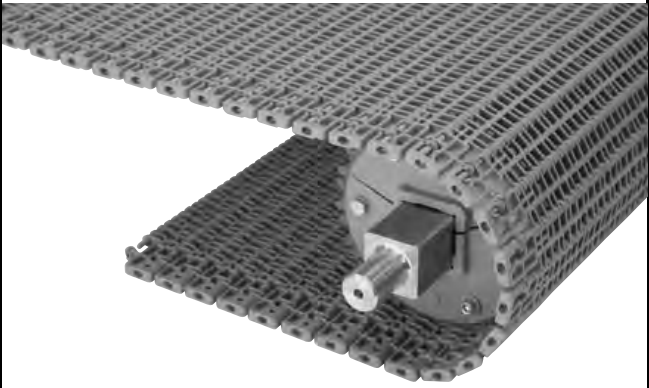
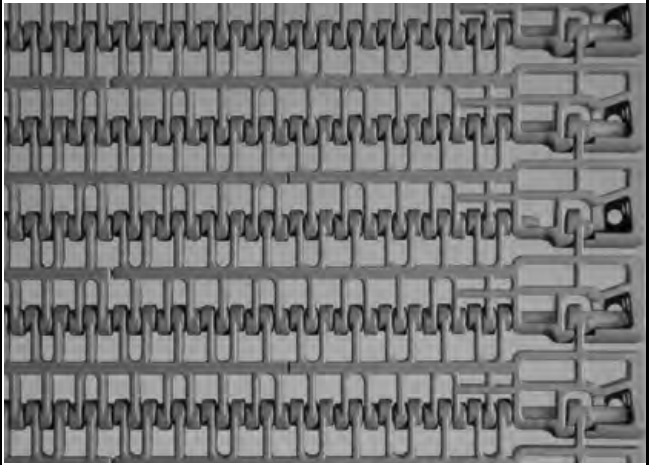
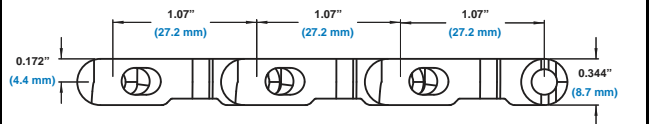



a. Belts made with nylon materials (HR and HHR) are available in whole inch width increments. For fractional belt width needs, please contact customer service.

Belt Data							
Belt Material	Standard Rod Material Ø 0.180 in (4.6 mm)	BS Belt Strength		Temperature Range (continuous)		W Belt Weight	
		lb/ft	kg/m	°F	°C	lb/ft ²	kg/m ²
Polypropylene	Polypropylene	700	1040	34 to 220	1 to 104	0.76	3.71
Acetal	Polypropylene	1480	2200	34 to 200	1 to 93	1.10	5.37
HR Nylon	HR Nylon	1200	1786	-50 to 240	-46 to 116	1.02	4.98
HHR Nylon	HHR Nylon	1200	1786	-50 to 310	-46 to 154	1.04	5.08

Mold to Width Flush Grid

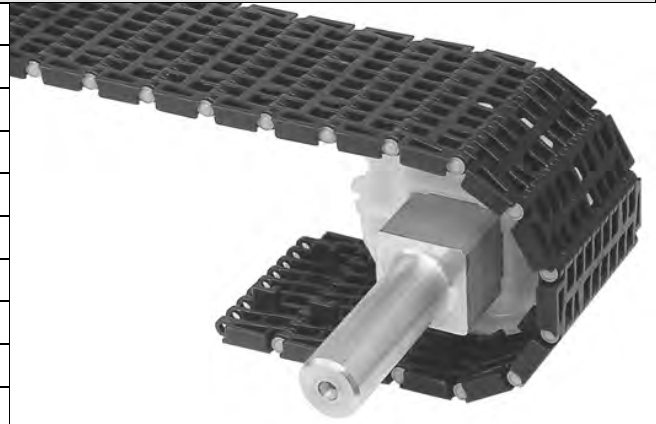
	in	mm
Pitch	1.07	27.2
Molded Widths	3.25	83
	4.5	114
	7.5	191
	-	85
Opening Size (approximate)	0.24 × 0.28	6.1 × 7.1
Open Area	38%	
Hinge Style	Open	
Drive Method	Center-driven	



Product Notes

- **Contact Intralox for precise belt measurements and stock status before designing equipment or ordering a belt.**
- Tracking tabs provide lateral tracking.
- Uses headed rods.
- **Series 900 Mold To Width** belts are boxed in 10 ft. (3.05 m) increments.
- Width tolerances for the **Series 900 Mold To Width** belts are +0.000/-0.020 in (+0.000/-0.500 mm).
- One sprocket can be placed on the 3.25 in (83 mm) and 85 mm mold to width belt. Up to three sprockets can be placed on the 4.5 in (114 mm) mold to width belt. Up to five sprockets can be placed on the 7.5 in (191 mm) mold to width belt.
- The **Series 900 Mold To Width** belt should not be used with sprockets smaller than a 3.5 in (89 mm) pitch diameter (10 tooth) sprocket. If a 3.5 in (89 mm) pitch diameter is required, the split sprocket should not be used.

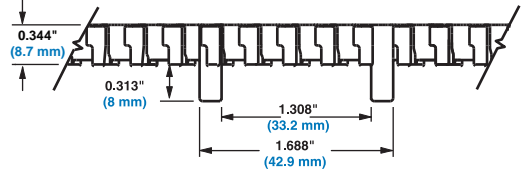
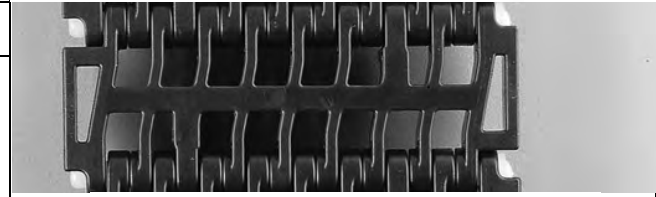

Series 900 Flush Grid Mold to Width



Arrow indicates preferred running direction

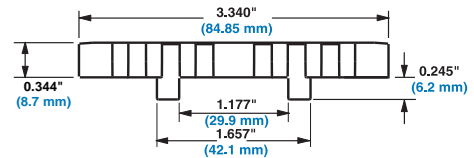

Series 900 Flush Grid 85 mm Mold to Width

Additional Information

- See "Belt Selection Process" (page 5)
- See "Standard Belt Materials" (page 9)
- See "Special Application Belt Materials" (page 9)
- See "Friction Factors" (page 13)

Belt Data

Belt Width		Belt Material	Standard Rod Material Ø 0.18 in (4.6 mm)	BS Belt Strength		Temperature Range (continuous)		W Belt Weight	
inch	(mm)			lb	kg	°F	°C	lb/ft	kg/m
3.25	83	Polypropylene	Nylon	130	59	34 to 220	1 to 104	0.31	0.46
3.25	83	Acetal	Nylon	250	113	-50 to 200	-46 to 93	0.42	0.62
4.5	114	Polypropylene	Nylon	263	120	34 to 220	1 to 104	0.39	0.58
4.5	114	Acetal	Nylon	555	252	-50 to 200	-46 to 93	0.54	0.80
7.5	191	Polypropylene	Nylon	438	199	34 to 220	1 to 104	0.59	0.88
7.5	191	Acetal	Nylon	800	363	-50 to 200	-46 to 93	0.85	1.26
	85	Acetal	Nylon	275	125	-50 to 200	-46 to 93	0.38	0.57

ONEPIECE™ Live Transfer Flush Grid

	in	mm
Pitch	1.07	27.2
Minimum Width	4.7	119
Width Increments	0.33	8.4
Opening Size (approximate)	0.24 x 0.28	6.1 x 7.1
Open Area	38%	
Hinge Style	Open	
Drive Method	Center-driven	



Product Notes

- **Contact Intralox for precise belt measurements and stock status before designing equipment or ordering a belt.**
- Transfer edge is an integral part of this belt.
- Uses headed rods.
- For custom belt widths please contact Customer Service.
- Belts available in 10 ft (3.05 m) length increments.
- Molded tracking tabs fit into standard 1-3/4 in (44.5 mm) wearstrip tracks ensuring proper belt alignment.
- Built with nylon rods for superior wear resistance.
- Also available in a 4.7 in (119 mm) wide single tracking tab belt and 6 in (152 mm) wide double tracking tab belt.
- For belt strength calculations, subtract 1.5 in (38 mm) from actual belt width.
- When product is moving from the transfer belt to a takeaway belt, the top of the transfer belt should be 0.06 in (1.5 mm) above the top of the takeaway belt. When product is moving from the infeed belt onto the transfer edge, the top of the belts should be level.
- You may need to include a fixed frame support member beneath the **ONEPIECE™ Live Transfer** belt prior to the actual transfer. This will ensure that the **ONEPIECE™ Live Transfer** belt does not snag when it intersects with the takeaway belt. See "Fig. 3-31 PARABOLIC GUIDE RAIL CONTOURS WITH 6.0 in. (152 mm) **ONEPIECE™ LIVE TRANSFER BELT**" (page 442).
- The **Series 900 ONEPIECE™ Live Transfer** belt should not be used with sprockets smaller than a 3.5 in (89 mm) pitch diameter (10 tooth) sprocket. If a 3.5 in (89 mm) pitch diameter is required, the split sprocket should not be used.

Additional Information

- See "Belt Selection Process" (page 5)
- See "Standard Belt Materials" (page 9)
- See "Special Application Belt Materials" (page 9)
- See "Friction Factors" (page 13)

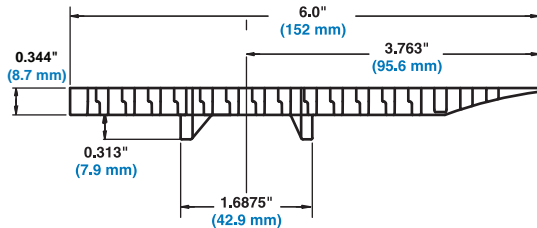

6.0 in (152 mm) Double Tracking Tab belt

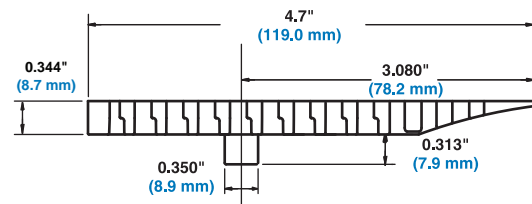

4.7 in (119 mm) Single Tracking Tab belt

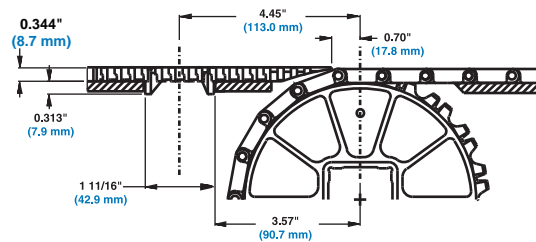

Belt Data

Belt Material	Standard Rod Material Ø 0.18 in (4.6 mm)	BS	Belt Strength	Temperature Range (continuous)		W	Belt Weight
				°F	°C		
Polypropylene	Nylon	700	1040	34 to 220	1 to 104	0.93	4.54
Acetal	Nylon	1480	2200	-50 to 200	-46 to 93	1.15	5.62
FR-TPES	Nylon	1000	1490	40 to 150	4 to 66	1.63	7.95

Raised Rib

	in	mm
Pitch	1.07	27.2
Minimum Width	2	51
Width Increments	0.33	8.4
Opening Size (approximate)	0.24 × 0.28	6.1 × 7.1
Open Area	38%	
Product Contact Area	35%	
Hinge Style	Open	
Drive Method	Center-driven	



Product Notes

- **Contact Intralox for precise belt measurements and stock status before designing equipment or ordering a belt.**
- Raised Ribs extend 3/16 in (4.7 mm) above basic module, with fully flush edges.
- Uses headed rods.
- Can be used with finger transfer plates eliminating product tippage and hang-ups.
- HR nylon is used in dry, elevated temperature applications.
- HR nylon belts use short rodlets to hold the main hinge rod in place. The rodlets are made from the same material as the main rod.

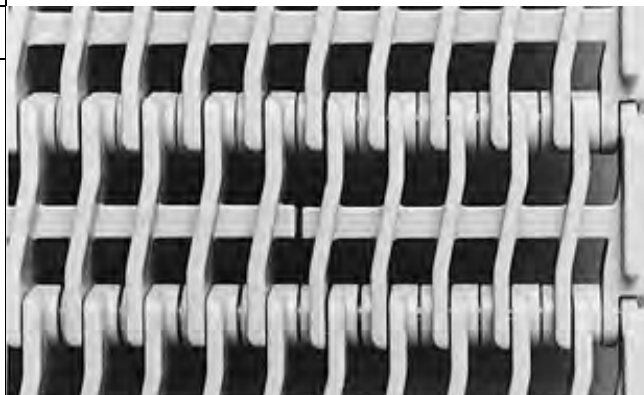

Additional Information

- See “Belt Selection Process” (page 5)
- See “Standard Belt Materials” (page 9)
- See “Special Application Belt Materials” (page 9)
- See “Friction Factors” (page 13)

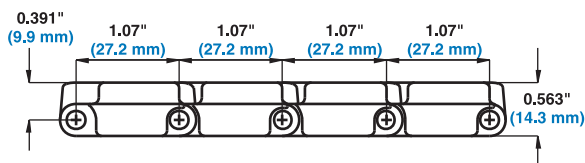

Belt Data

Belt Material	Standard Rod Material Ø 0.18 in (4.6 mm)	BS		Temperature Range (continuous)		W	
		Belt Strength	Belt Strength	°F	°C	Belt Weight	Belt Weight
		lb/ft	kg/m			lb/ft ²	kg/m ²
Polypropylene	Polypropylene	700	1040	34 to 220	1 to 104	1.07	5.21
Enduralox Polypropylene	Polypropylene	700	1040	34 to 220	1 to 104	1.07	5.21
Polyethylene	Polyethylene	350	520	-50 to 150	-46 to 66	1.14	5.57
Acetal	Polypropylene	1480	2200	34 to 200	1 to 93	1.68	8.19
HSEC Acetal	Polypropylene	800	1190	34 to 200	1 to 93	1.68	8.19
HR Nylon ^a	Nylon	1200	1790	-50 to 240	-46 to 116	1.60	7.80
HHR Nylon	Nylon	1200	1790	-50 to 310	-46 to 154	1.60	7.80
Acetal ^b	Polyethylene	1000	1490	-50 to 70	-46 to 21	1.68	8.19

a. This product cannot be used for food contact articles that will come in contact with food containing alcohol.

b. Polyethylene rods can be used in cold applications when impacts or sudden starts/stops occur. Please note lower rating.

Mold to Width Raised Rib

	in	mm
Pitch	1.07	27.2
Molded Widths (Blue acetal)	1.1	29
	1.5	37
	1.8	46
	2.2	55
Opening Size (approximate)	0.24 × 0.28	6.1 × 7.1
Open Area	38% - 40%	
Hinge Style	Closed	
Drive Method	Center-driven	



Product Notes

- **Contact Intralox for precise belt measurements and stock status before designing equipment or ordering a belt.**
- **Series 900 Mold To Width** belts are boxed in 10 ft (3.05 m) increments.
- Container stability is increased since the raised ribs span the entire belt width.
- Uses headed rods.
- These belts support both small and larger products, allowing easy change of product type.
- The 1.8 in (46 mm) belt is also molded in grey polypropylene for applications where higher friction is needed.
- All belts come with nylon rodlets standard, providing longer service life.

Additional Information

- See “Belt Selection Process” (page 5)
- See “Standard Belt Materials” (page 9)
- See “Special Application Belt Materials” (page 9)
- See “Friction Factors” (page 13)

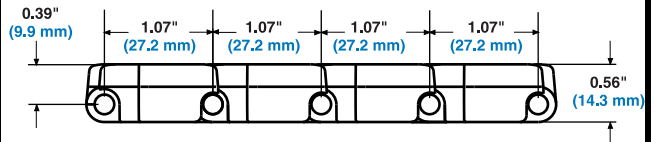

SECTION 2

900

Belt Data

Belt Width		Belt Material	Standard Rod Material Ø 0.18 in. (4.6 mm)	BS Belt Strength		Temperature Range (continuous)		W Belt Weight	
inch	(mm)			lb	kg	°F	°C	lb/ft	kg/m
1.1	29	Acetal	Nylon	140	64	-50 to 200	-46 to 93	0.19	0.29
1.5	37	Acetal	Nylon	200	91	-50 to 200	-46 to 93	0.23	0.35
1.8	46	Acetal	Nylon	230	104	-50 to 200	-46 to 93	0.29	0.43
1.8	46	Polypropylene	Nylon	90	41	34 to 220	1 to 104	0.19	0.28
2.2	56	Acetal	Nylon	200 ^a	91 ^a	-50 to 200	-46 to 93	0.34	0.50

a. 270 lb (122 kg) for 2.2 in. (56 mm) with two (2) sprockets.

Flat Top

	in	mm
Pitch	1.07	27.2
Minimum Width	2	51
Width Increments	0.33	8.4
Opening Size (approximate)	-	-
Open Area	0%	
Hinge Style	Closed	
Drive Method	Center-driven	



Product Notes

- **Contact Intralox for precise belt measurements and stock status before designing equipment or ordering a belt.**
- Smooth, closed surface with fully flush edges.
- Uses headed rods.
- Ideal for container handling, especially glass.
- HR nylon is used in dry, elevated temperature applications.
- HR nylon belts use short rodlets to hold the main hinge rod in place. The rodlets are made from the same material as the main rod.

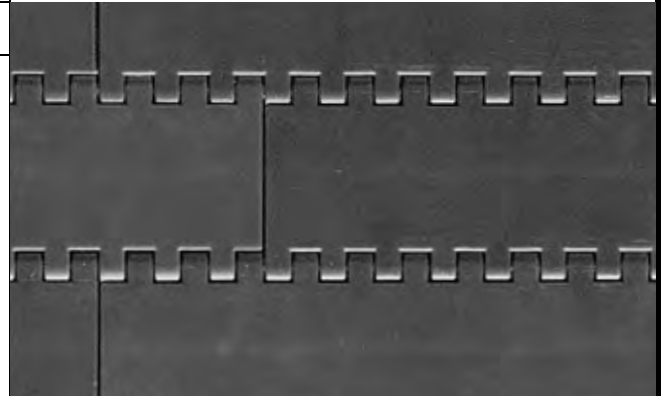

Additional Information

- See "Belt Selection Process" (page 5)
- See "Standard Belt Materials" (page 9)
- See "Special Application Belt Materials" (page 9)
- See "Friction Factors" (page 13)

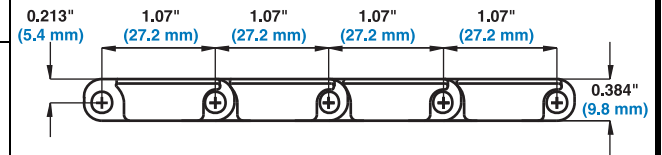

Belt Data

Belt Material	Standard Rod Material Ø 0.18 in (4.6 mm)	BS Belt Strength		Temperature Range (continuous)		W Belt Weight	
		lb/ft	kg/m	°F	°C	lb/ft ²	kg/m ²
Polypropylene	Polypropylene	700	1040	34 to 220	1 to 104	0.96	4.69
Polyethylene	Polyethylene	350	520	-50 to 150	-46 to 66	1.01	4.95
Acetal	Polypropylene	1480	2200	34 to 200	1 to 93	1.50	7.30
HSEC Acetal	Polypropylene	800	1190	34 to 200	1 to 93	1.50	7.30
HR Nylon ^a	Nylon	1200	1790	-50 to 240	-46 to 116	1.40	6.80
HHR Nylon	Nylon	1200	1790	-50 to 310	-46 to 154	1.40	6.80
Acetal ^b	Polyethylene	1000	1490	-50 to 70	-46 to 21	1.50	7.30

a. This product cannot be used for food contact articles that will come in contact with food containing alcohol.

b. Polyethylene rods can be used in cold applications when impacts or sudden starts/stops occur. Please note lower rating.

Mold to Width Flat Top

	in	mm
Pitch	1.07	27.2
Molded Widths	3.25	83
	4.5	114
	7.5	191
	-	85
Opening Size (approximate)	-	-
Open Area	0%	
Hinge Style	Open	
Drive Method	Center-driven	

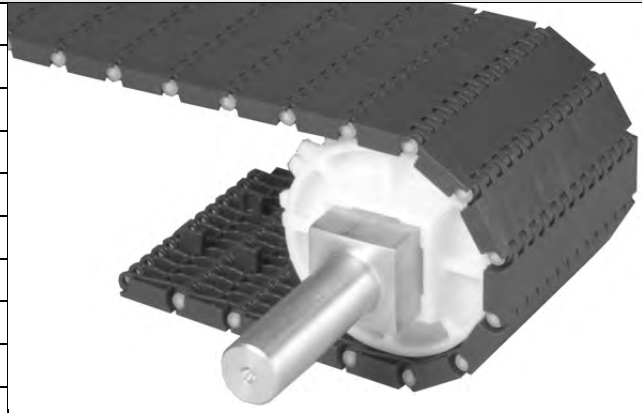

Product Notes

- **Contact Intralox for precise belt measurements and stock status before designing equipment or ordering a belt.**
- Smooth, closed surface with fully flush edges.
- Uses headed rods.
- Tracking tabs provide lateral tracking.
- **Series 900 Mold To Width** belts are boxed in 10 ft (3.1 m) increments.
- One sprocket can be placed on the 3.25 in (83 mm) and 85 mm mold to width belt. Up to three sprockets can be placed on the 4.5 in (114 mm) mold to width belt. Up to five sprockets can be placed on the 7.5 in (191 mm) mold to width belt.
- The **Series 900 Mold To Width** belt should not be used with sprockets smaller than a 3.5 in (89 mm) pitch diameter (10 tooth) sprocket. If a 3.5 in (89 mm) pitch diameter is required, the split sprocket should not be used.

Additional Information

- See “Belt Selection Process” (page 5)
- See “Standard Belt Materials” (page 9)
- See “Special Application Belt Materials” (page 9)
- See “Friction Factors” (page 13)

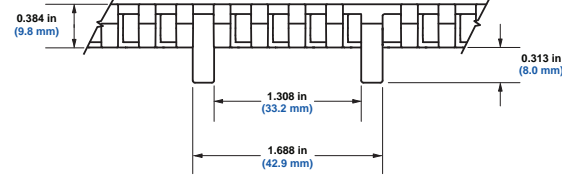
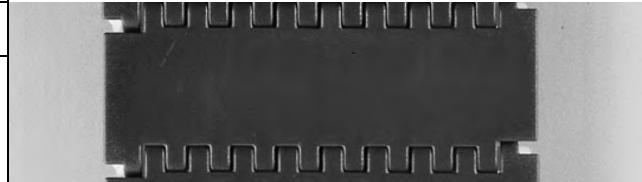

Series 900 Flat Top Mold to Width

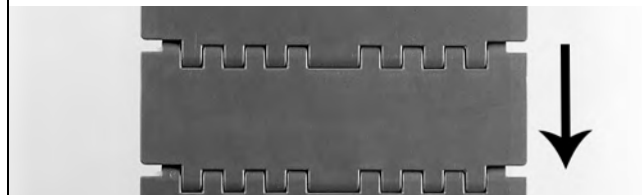

Arrow indicates preferred running direction

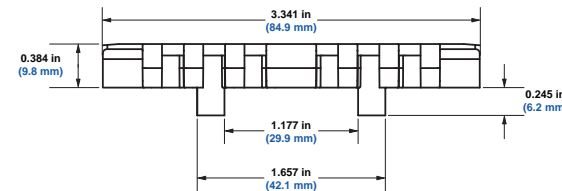

Series 900 Flat Top 85 mm Mold to Width

Belt Data

Belt Width		Belt Material	Standard Rod Material Ø 0.18 in (4.6 mm)	BS Belt Strength		Temperature Range (continuous)		W Belt Weight	
inch	(mm)			lb	kg	°F	°C	lb/ft	kg/m
3.25	83	Polypropylene	Nylon	130	59	34 to 220	1 to 104	0.37	0.55
3.25	83	Acetal	Nylon	250	113	-50 to 200	-46 to 93	0.52	0.77
4.5	114	Polypropylene	Nylon	263	120	34 to 220	1 to 104	0.52	0.77
4.5	114	Acetal	Nylon	555	252	-50 to 200	-46 to 93	0.74	1.10
7.5	191	Polypropylene	Nylon	438	199	34 to 220	1 to 104	0.83	1.24
7.5	191	Acetal	Nylon	800	363	-50 to 200	-46 to 93	1.18	1.76
	85	Acetal	Nylon	500	227	-50 to 200	-46 to 93	0.50	0.74

ONEPIECE™ Live Transfer Flat Top

	in	mm
Pitch	1.07	27.2
Minimum Width	4.7	119
Width Increments	0.33	8.4
Opening Size (approximate)	-	-
Open Area	0%	
Hinge Style	Closed	
Drive Method	Center-driven	

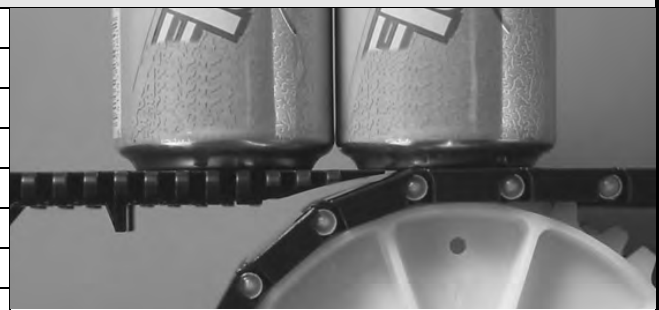

Product Notes

- **Contact Intralox for precise belt measurements and stock status before designing equipment or ordering a belt.**
- Transfer edge is an integral part of this belt.
- Uses headed rods.
- For custom belt widths, please contact Customer Service.
- Belts available in 10 ft (3.05 m) length increments.
- Molded tracking tabs fit into standard 1-3/4 in (44.5 mm) wearstrip tracks ensuring proper belt alignment.
- Built with nylon rods for superior wear resistance.
- Also available in a 4.7 in (119 mm) wide single tracking tab belt and 6 in (152 mm) wide double tracking tab belt.
- When product is moving from the transfer belt to a takeaway belt, the top of the transfer belt should be 0.06 in (1.5 mm) above the top of the takeaway belt. When product is moving from the infeed belt onto the transfer edge, the top of the belts should be level.
- You may need to include a fixed frame support member beneath the **ONEPIECE™ Live Transfer** belt prior to the actual transfer. This will ensure that the **ONEPIECE™ Live Transfer** belt does not snag when it intersects with the takeaway belt. See "Fig. 3-31 PARABOLIC GUIDE RAIL CONTOURS WITH 6.0 in. (152 mm) **ONEPIECE™ LIVE TRANSFER BELT**" (page 442)
- The Series 900 **ONEPIECE™ Live Transfer** belt should not be used with sprockets smaller than a 3.5 in (89 mm) pitch diameter (10 tooth) sprocket. If a 3.5 in (89 mm) pitch diameter is required, the split sprocket should not be used.

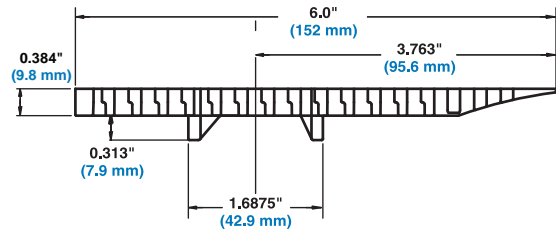

6.0 in (152 mm) Double Tracking Tab belt

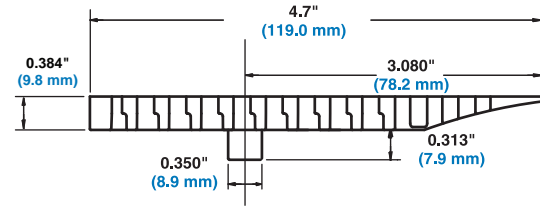

4.7 in (119 mm) Single Tracking Tab belt

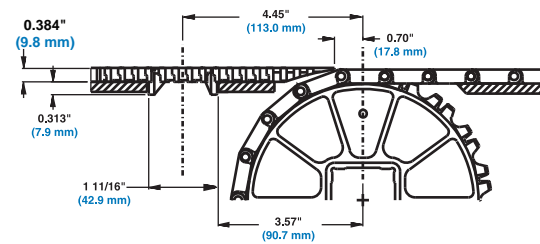

Additional Information

- See "Belt Selection Process" (page 5)
- See "Standard Belt Materials" (page 9)
- See "Special Application Belt Materials" (page 9)
- See "Friction Factors" (page 13)

Belt Data

Belt Material	Standard Rod Material Ø 0.18 in (4.6 mm)	BS		Temperature Range (continuous)		W	
		Belt Strength lb/ft	kg/m	°F	°C	Belt Weight lb/ft²	kg/m²
Polypropylene	Nylon	700	1040	34 to 220	1 to 104	0.93	4.54
Acetal	Nylon	1480	2200	-50 to 200	-46 to 93	1.50	7.30

Perforated Flat Top		
	in	mm
Pitch	1.07	27.2
Minimum Width	2	51
Width Increments	0.33	8.4
Opening Size (approximate)	See Product Notes	
Open Area	See Product Notes	
Hinge Style	Closed	
Drive Method	Center-driven	
Product Notes		
<ul style="list-style-type: none"> • Contact Intralox for precise belt measurements and stock status before designing equipment or ordering a belt. • Available hole sizes: <ul style="list-style-type: none"> Ø 1/8 in (3.2 mm) - 5% Open Area Ø 5/32 in (4.0 mm) - 6% Open Area Ø 3/16 in (4.8 mm) - 8% Open Area • All hole sizes include 3% open area at the hinge. • Uses headed rods. • Designed for vacuum transfer applications, with a scalloped underside to reduce carryway blockage. • All holes have a radiused top edge allowing quiet operation and good vacuum performance. • Other hole dimensions and patterns can be created by drilling Series 900 Flat Top. • For elevated temperatures, use stainless steel split sprockets. • HR nylon belts use short rodlets to hold the main hinge rod in place and are made from the same material as the main rod. 		
Additional Information		
<ul style="list-style-type: none"> • See "Belt Selection Process" (page 5) • See "Standard Belt Materials" (page 9) • See "Special Application Belt Materials" (page 9) • See "Friction Factors" (page 13) 		

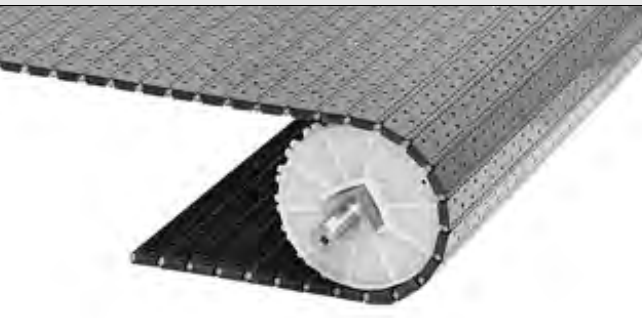

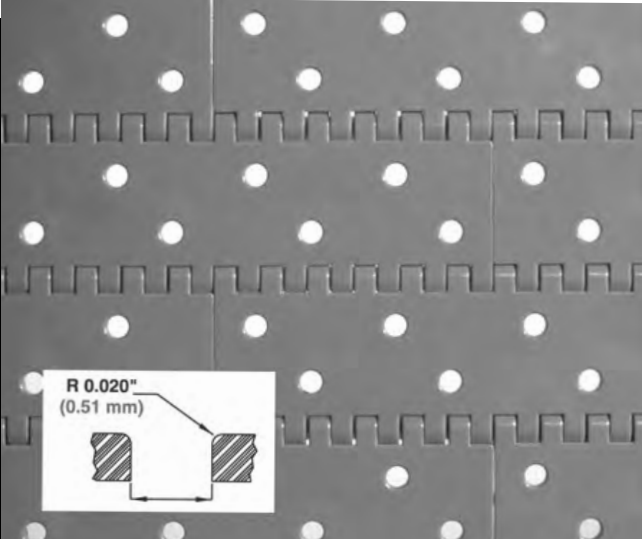

R 0.020"
(0.51 mm)

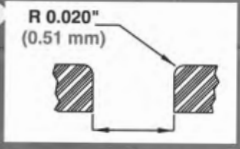

INSET: MOLDED HOLE DETAIL

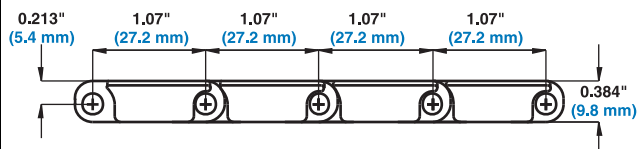

Belt Data											
Belt Material	Standard Rod Material Ø 0.18 in (4.6 mm)	BS Belt Strength		Temperature Range (continuous)		W Belt Weight 1/8 in		W Belt Weight 5/32 in		W Belt Weight 3/16 in	
						lb/ft ²	kg/m ²	lb/ft ²	kg/m ²	lb/ft ²	kg/m ²
Polypropylene	Polypropylene	700	1040	34 to 220	1 to 104	–	–	0.93	4.54	–	–
Polyethylene	Polyethylene	350	520	-50 to 150	-46 to 66	–	–	0.98	4.79	–	–
Acetal	Polypropylene	1480	2200	34 to 200	1 to 93	1.48	7.23	1.46	7.11	1.43	6.98
HSEC Acetal	Polypropylene	800	1190	34 to 200	1 to 93	–	–	1.46	7.11	–	–
FR-TPES	Polypropylene	750	1120	40 to 150	4 to 66	–	–	1.59	7.76	–	–
HR Nylon ^a	Nylon	1200	1790	-50 to 240	-46 to 116	–	–	1.40	6.80	–	–
Acetal ^b	Polyethylene	1000	1490	-50 to 70	-46 to 21	1.48	7.23	1.46	7.11	1.43	6.98
UVFR	UVFR	700	1042	-34 to 200	1 to 93	2.04	9.96	2.04	9.96	2.04	9.96

a. This product cannot be used for food contact articles that will come in contact with food containing alcohol
 b. Polyethylene rods can be used in cold applications when impacts or sudden starts/stops occur. Please note lower rating. 1/8 in (3.2 mm) and 3/16 in (4.8 mm) hole sizes are available in acetal only.

Mesh Top™		
	in	mm
Pitch	1.07	27.2
Minimum Width	2	51
Width Increments	0.33	8.4
Opening Size (approximate)	0.05 × 0.31	1.3 × 7.9
Open Area	24%	
Hinge Style	Open	
Drive Method	Center-driven	
Product Notes		
<ul style="list-style-type: none"> • Contact Intralox for precise belt measurements and stock status before designing equipment or ordering a belt. • Fully flush edges. • Uses headed rods. • Ideal for fruit and vegetable processing, especially for stemmed products and dewatering applications. 		
Additional Information		
<ul style="list-style-type: none"> • See “Belt Selection Process” (page 5) • See “Standard Belt Materials” (page 9) • See “Special Application Belt Materials” (page 9) • See “Friction Factors” (page 13) 		

Top surface

Underside surface

Belt Data							
Belt Material	Standard Rod Material Ø 0.18 in (4.6 mm)	BS Belt Strength		Temperature Range (continuous)		W Belt Weight	
		lb/ft	kg/m	°F	°C	lb/ft ²	kg/m ²
Acetal	Polypropylene	1480	2200	34 to 200	1 to 93	1.39	6.79
Polypropylene	Polypropylene	700	1040	34 to 220	1 to 104	0.93	4.55
Polyethylene	Polyethylene	350	520	-50 to 150	-46 to 66	0.99	4.84

Intralox® Diamond Friction Top		
	in	mm
Pitch	1.07	27.2
Minimum Width	3.0	76
Width Increments	0.33	8.4
Hinge Style	Open	
Drive Method	Center-driven	
Product Notes		
<ul style="list-style-type: none"> Contact Intralox for precise belt measurements and stock status before designing equipment or ordering a belt. Two material rubber modules provide a high friction surface without interfering with carryways and sprockets. Uses headed rods. Available in grey PP with black rubber, white PP with white rubber, and natural PE with white rubber. Not recommended for back-up conditions. If friction values between product and belt are required, contact Intralox Sales Engineering. If a center-drive setup is used, it may be necessary to place collars to laterally retain the belt at the backbend roller before the drive. Abrasion resistant rods are recommended. Temperature, environmental conditions, and product characteristics affect the effective maximum degree of incline. Take these items into consideration when designing conveyor systems utilizing these belts. Minimum nominal alternating edge indents of 1 in (25 mm) and 1.7 in (43 mm). 		
Additional Information		
<ul style="list-style-type: none"> See "Belt Selection Process" (page 5) See "Standard Belt Materials" (page 9) See "Special Application Belt Materials" (page 9) See "Friction Factors" (page 13) 		

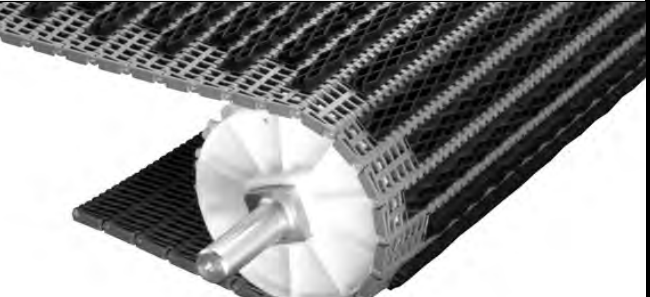
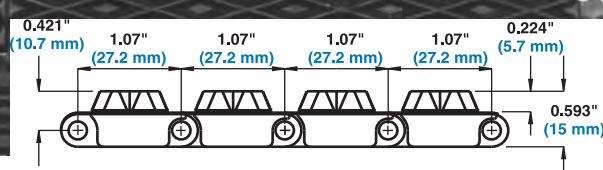
Belt Data											
Base Belt Material	Base/Friction Color	Standard Rod Material Ø 0.18 in (4.6 mm)	BS		Temperature Range (continuous)		W		Friction Top Hardness	Agency Acceptability	
			lb/ft	kg/m	°F	°C	lb/ft²	kg/m²		FDA (USA)	EU MC ^b
Polypropylene	Grey/Black	Polypropylene	1000	1490	34 to 150	1 to 66	1.40	6.83	45 Shore A	a	
Polypropylene	White/White	Polypropylene	1000	1490	34 to 150	1 to 66	1.40	6.83	56 Shore A	a	c
Polyethylene	Natural/White	Polyethylene	350	520	-50 to 120	-46 to 49	1.50	7.32	56 Shore A	a	c

• - Fully compliant

a - FDA Compliant with Restriction: Do not use in direct contact with fatty foods.

b - European Migration Certificate providing approval for food contact according to EU Regulation 10/2011.

c - EU compliant with Restriction: Do not use in direct contact with fatty foods.

Square Friction Top

	in	mm
Pitch	1.07	27.2
Minimum Width	3.0	76
Width Increments	0.33	8.4
Hinge Style	Open	
Drive Method	Center-driven	

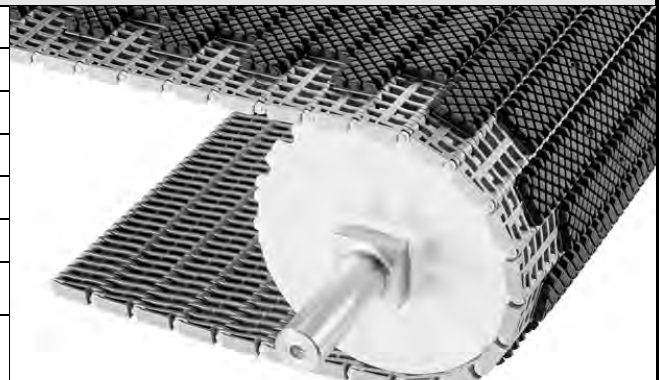

Product Notes

- **Contact Intralox for precise belt measurements and stock status before designing equipment or ordering a belt.**
- Two material rubber modules provide a high friction surface without interfering with carryways and sprockets.
- Uses headed rods.
- Available in grey PP with black rubber and white PP with white rubber.
- Not recommended for back-up conditions. If friction values between product and belt are required, contact Intralox Sales Engineering.
- If a center-drive setup is used, it may be necessary to place collars to laterally retain the belt at the backbend roller before the drive. Abrasion resistant rods are recommended.
- Temperature, environmental conditions, and product characteristics affect the effective maximum degree of incline. Take these items into consideration when designing conveyor systems utilizing these belts.
- Minimum nominal alternating edge indents of 1 in (25 mm) and 1.7 in and (43 mm).

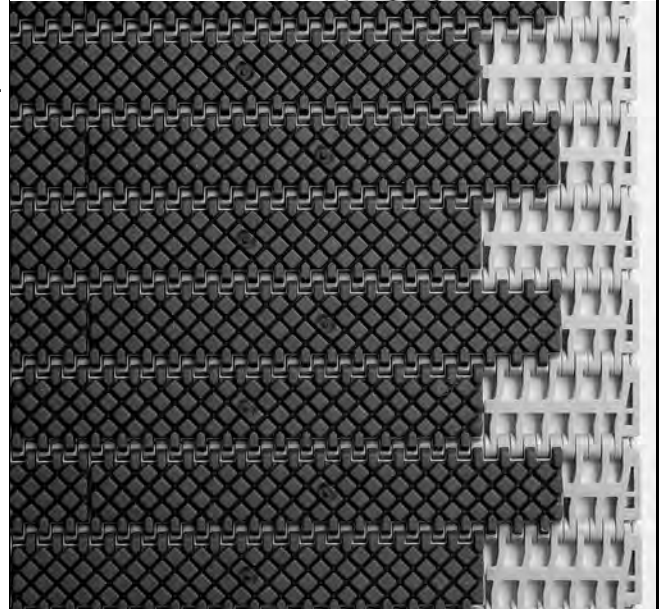

Additional Information

- See "Belt Selection Process" (page 5)
- See "Standard Belt Materials" (page 9)
- See "Special Application Belt Materials" (page 9)
- See "Friction Factors" (page 13)

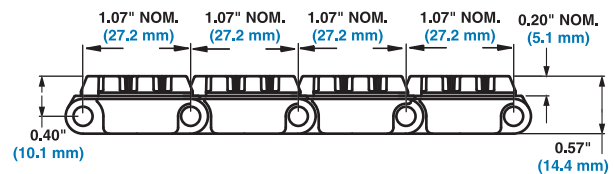

Belt Data

Base Belt Material	Base/Friction Color	Standard Rod Material Ø 0.18 in (4.6 mm)	BS Belt Strength		Temperature Range (continuous)		W Belt Weight		Friction Top Hardness	Agency Acceptability	
			lb/ft	kg/m	°F	°C	lb/ft²	kg/m²		FDA (USA)	EU MC ^b
Polypropylene	Grey/Black	Polypropylene	1000	1490	34 to 150	1 to 66	1.50	7.32	45 Shore A	a	
Polypropylene	White/White	Polypropylene	1000	1490	34 to 150	1 to 66	1.50	7.32	56 Shore A	a	c

• - Fully compliant

a - FDA Compliant with Restriction: Do not use in direct contact with fatty foods.

b - European Migration Certificate providing approval for food contact according to EU Regulation 10/2011.

c - EU compliant with Restriction: Do not use in direct contact with fatty foods.

Mold to Width 29 mm Square Friction Top

	in	mm
Pitch	1.07	27.2
Molded Width	1.1	29
Hinge Style	Closed	
Drive Method	Center-driven	

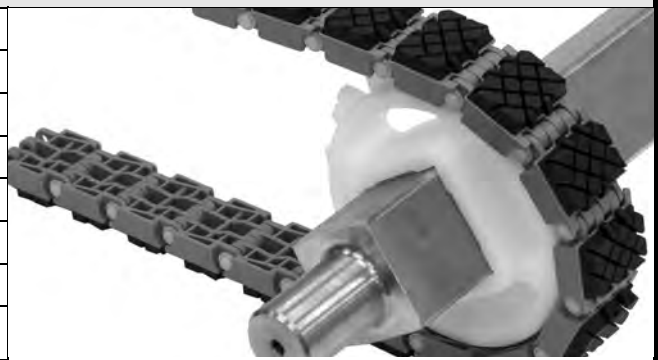

Product Notes

- Contact Intralox for precise belt measurements and stock status before designing equipment or ordering a belt.
- Two material rubber modules provide a high friction surface without interfering with carryways and sprockets.
- Uses headed rods.
- Available in grey PP with black rubber, grey acetal with black rubber, and blue acetal with black rubber.
- Not recommended for back-up conditions. If friction values between product and belt are required, contact Intralox Sales Engineering.

Additional Information

- See "Belt Selection Process" (page 5)
- See "Standard Belt Materials" (page 9)
- See "Special Application Belt Materials" (page 9)
- See "Friction Factors" (page 13)

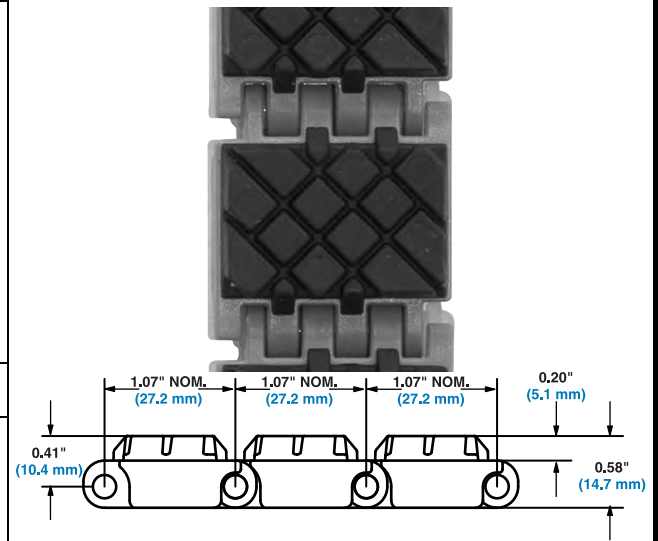

Belt Data

Base Belt Material	Base/Friction Color	Standard Rod Material Ø 0.18 in (4.6 mm)	BS		Temperature Range (continuous)		W		Friction Top Hardness	Agency Acceptability	
			lb	kg	°F	°C	lb/ft	kg/m		FDA (USA)	EU MC ^b
Polypropylene	Grey/Black	Nylon	65	29	34 to 150	1 to 66	0.17	0.25	45 Shore A	a	
Acetal	Grey/Black	Nylon	140	64	-10 to 130	-23 to 54	0.21	0.31	54 Shore A		
Acetal	Blue/Black	Nylon	140	64	-10 to 130	-23 to 54	0.21	0.31	54 Shore A		

• - Fully compliant

a - FDA Compliant with Restriction: Do not use in direct contact with fatty foods.

b - European Migration Certificate providing approval for food contact according to EU Regulation 10/2011.

c - EU compliant with Restriction: Do not use in direct contact with fatty foods.

Intralox® Flat Friction Top		
	in	mm
Pitch	1.07	27.2
Minimum Width	3.0	76
Width Increments	0.33	8.4
Hinge Style	Open	
Drive Method	Center-driven	
Product Notes		
<ul style="list-style-type: none"> Contact Intralox for precise belt measurements and stock status before designing equipment or ordering a belt. Available in grey PP with black rubber and white PP with white rubber. Uses headed rods. Two material rubber modules provide a high friction surface without interfering with carryways and sprockets. Not recommended for back-up conditions. If friction values between product and belt are required, contact Intralox Sales Engineering. If a center-drive setup is used, it may be necessary to place collars to laterally retain the belt at the backbend roller before the drive. Abrasion resistant rods are recommended. Temperature, environmental conditions, and product characteristics affect the effective maximum degree of incline. Take these items into consideration when designing conveyor systems utilizing these belts. Minimum nominal alternating edge indents of 1 in (25 mm) and 1.7 in (43 mm) . 		
Additional Information		
<ul style="list-style-type: none"> See "Belt Selection Process" (page 5) See "Standard Belt Materials" (page 9) See "Special Application Belt Materials" (page 9) See "Friction Factors" (page 13) 		

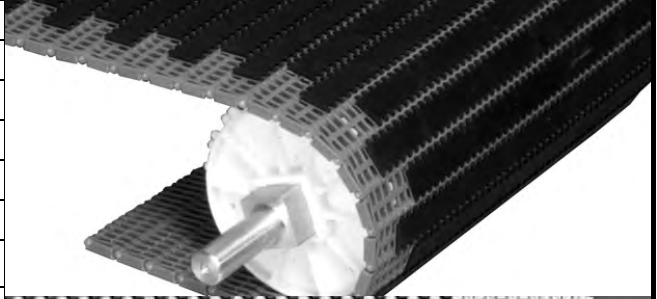
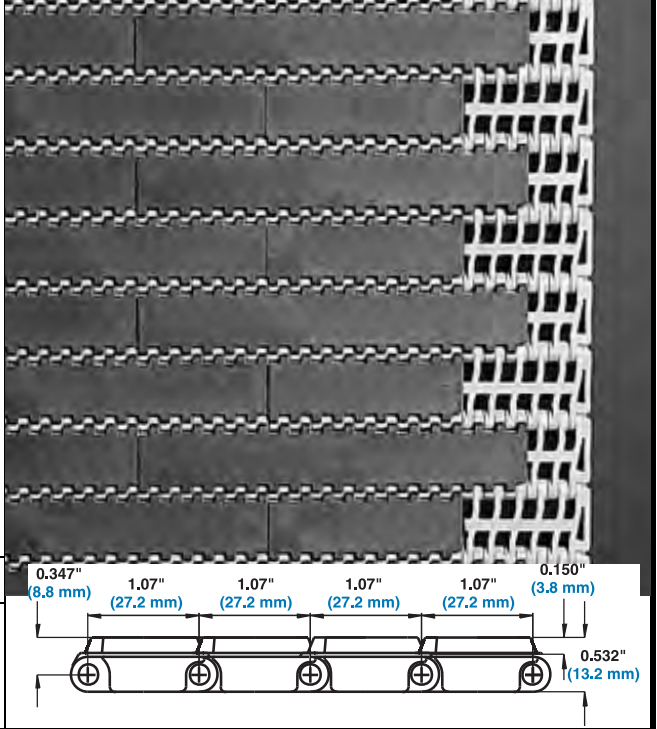
Belt Data											
Base Belt Material	Base/Friction Color	Standard Rod Material Ø 0.18 in (4.6 mm)	BS		Temperature Range (continuous)		W		Friction Top Hardness	Agency Acceptability	
			lb/ft	kg/m	°F	°C	lb/ft²	kg/m²		FDA (USA)	EU MC ^b
Polypropylene	Grey/Black	Polypropylene	1000	1490	34 to 150	1 to 66	1.40	6.83	45 Shore A	a	
Polypropylene	White/White	Polypropylene	1000	1490	34 to 150	1 to 66	1.40	6.83	56 Shore A	a	c
Polypropylene	High Performance FT Blue/Blue	Polypropylene	1000	1490	34 to 212	1 to 100	1.40	6.83	59 Shore A	a	c

• - Fully compliant

a - FDA Compliant with Restriction: Do not use in direct contact with fatty foods.

b - European Migration Certificate providing approval for food contact according to EU Regulation 10/2011.

c - EU compliant with Restriction: Do not use in direct contact with fatty foods.

Flush Grid with Insert Rollers

	in	mm
Pitch	1.07	27.2
Minimum Width	6	152
Width Increments	1.00	25.4
Opening Size (approx.)	0.24 x 0.28	6.1 x 7.1
Open Area	38%	
Hinge Style	Open	
Drive Method	Center-driven	

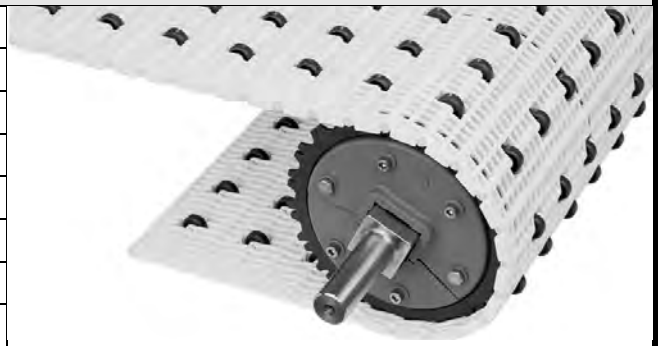

Product Notes

- **Contact Intralox for precise belt measurements and stock status before designing equipment or ordering a belt.**
- For applications where low back pressure accumulation is required.
- Acetal rollers
- Uses headed rods.
- Standard roller spacings across belt width: 2 in (51 mm), 3 in (76 mm), or 4 in (102 mm) inline or staggered.
- Standard roller spacings along belt length: 1.07 in (27.2 mm), 2.14 in (54.4 mm).
- Minimum 1.0 in (25.4 mm) roller indent.
- Contact Customer Service for non-standard roller placement options.
- Sprockets must NOT be placed inline with rollers.
- For low back pressure applications, place wearstrip between rollers. For driven applications, place wearstrip directly under rollers.
- Back-up load is 5% to 10% of product weight.

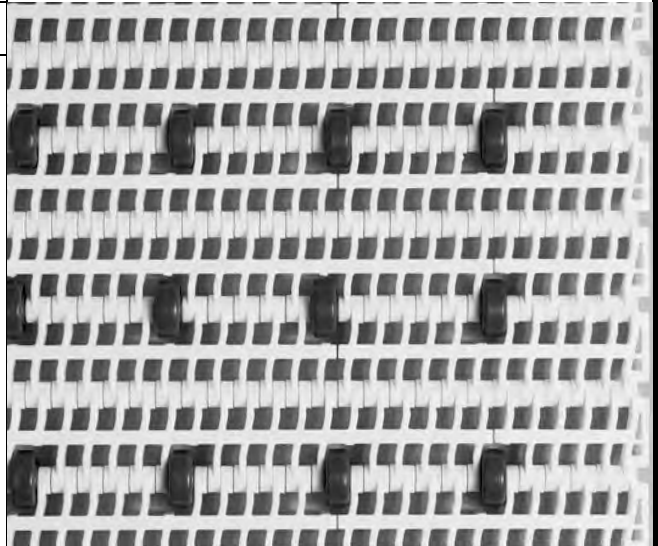

Additional Information

- See "Belt Selection Process" (page 5)
- See "Standard Belt Materials" (page 9)
- See "Special Application Belt Materials" (page 9)
- See "Friction Factors" (page 13)

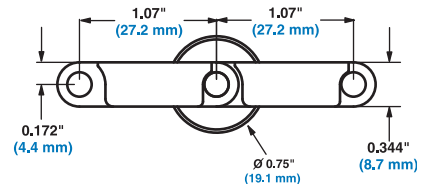

Belt Data

Belt Material	Standard Rod Material Ø 0.18 in (4.6 mm)	BS Belt Strength						Temperature Range (continuous)		W Belt Weight	
		Roller Width Spacing						°F	°C	lb/ft ²	kg/m ²
		2 in	51 mm	3 in	76 mm	4 in	102 mm				
		lb/ft	kg/m	lb/ft	kg/m	lb/ft	kg/m				
Polypropylene	Polypropylene	490	730	550	820	590	880	34 to 220	1 to 104	0.76	3.71
Acetal	Polypropylene	1030	1530	1170	1740	1240	1850	34 to 200	1 to 93	1.15	5.61

Nub Top™		
	in	mm
Pitch	1.07	27.2
Minimum Width	10	254
Width Increments	0.33	8.4
Open Area	0%	
Product Contact Area	7%	
Hinge Style	Closed	
Drive Method	Center-driven	
Product Notes		
<ul style="list-style-type: none"> • Contact Intralox for precise belt measurements and stock status before designing equipment or ordering a belt. • Fully flush edges. • Uses headed rods. • Ideal for batch-off applications. • Minimum nominal alternating edge indents of 2 in (51 mm) & 3 in (76 mm). 		
Additional Information		
<ul style="list-style-type: none"> • See "Belt Selection Process" (page 5) • See "Standard Belt Materials" (page 9) • See "Special Application Belt Materials" (page 9) • See "Friction Factors" (page 13) 		

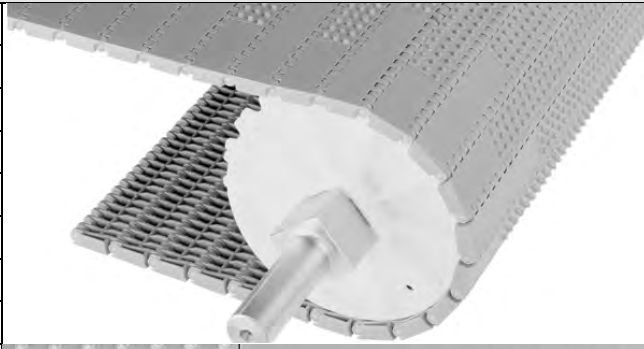
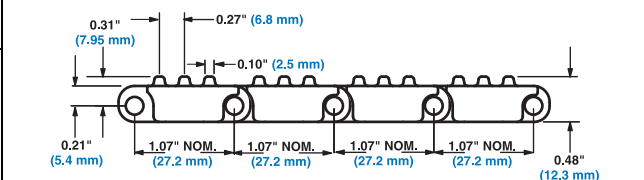
Belt Data							
Belt Material	Standard Rod Material Ø 0.18 in (4.6 mm)	BS Belt Strength ^a		Temperature Range (continuous)		W Belt Weight	
		lb/ft	kg/m	°F	°C	lb/ft ²	kg/m ²
Polypropylene	Polypropylene	700	1040	34 to 220	1 to 104	0.98	4.78

a. When using steel sprockets, the belt strength for polyethylene is 240 lb/ft (360 kg/m). Contact Customer Service for availability of polyurethane sprockets.

Flush Grid Nub Top™		
	in	mm
Pitch	1.07	27.2
Minimum Width	6	152
Width Increments	0.33	8.4
Opening Size (approximate)	0.24 × 0.28	6.1 × 7.1
Open Area	38%	
Product Contact Area	3%	
Hinge Style	Open	
Drive Method	Center-driven	
Product Notes		
<ul style="list-style-type: none"> • Contact Intralox for precise belt measurements and stock status before designing equipment or ordering a belt. • Can only be used with Series 900 Flush Grid base flights. • Fully flush edges. • Uses headed rods. • Belts are built with Flush Grid edge modules. Minimum nominal alternating edge indents of 1 in (25 mm) and 2 in (51 mm) pattern. • Not recommended for back-up conditions. If friction values between product and belt are required, contact Intralox Sales Engineering. 		
Additional Information		
<ul style="list-style-type: none"> • See “Belt Selection Process” (page 5) • See “Standard Belt Materials” (page 9) • See “Special Application Belt Materials” (page 9) • See “Friction Factors” (page 13) 		



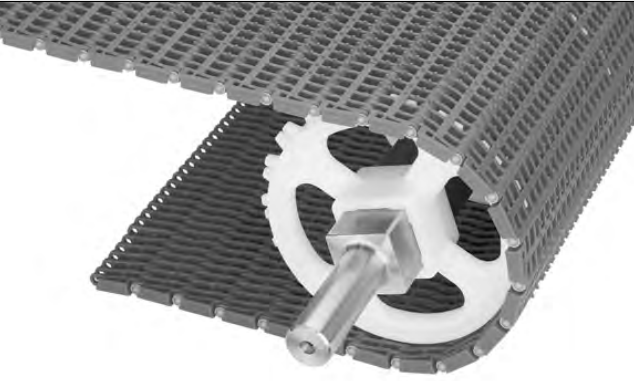
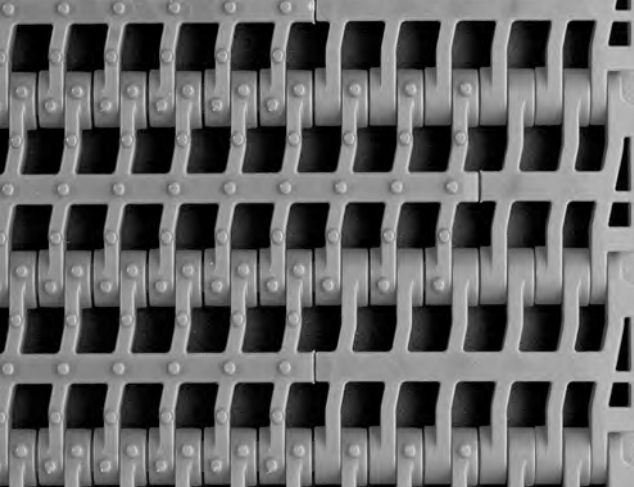
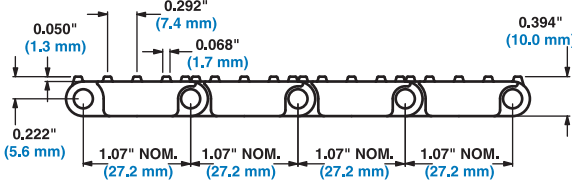

Belt Data							
Belt Material	Standard Rod Material Ø 0.18 in (4.6 mm)	BS	Belt Strength ^a	Temperature Range (continuous)		W	Belt Weight
				°F	°C		
Polypropylene	Polypropylene	700	1040	34 to 220	1 to 104	0.80	3.91

a. When using steel sprockets, the belt strength for polyethylene is 240 lb/ft (360 kg/m).

Sprocket and Support Quantity Reference				
Belt Width Range ^a		Minimum Number of Sprockets Per Shaft ^b	Wearstrips	
in.	mm		Carryway	Returnway ^c
2	51	1	2	2
4	102	1	2	2
6	152	2	2	2
7	178	2	3	2
8	203	2	3	2
10	254	3	3	2
12	305	3	3	2
14	356	5	4	3
15	381	5	4	3
16	406	5	4	3
18	457	5	4	3
20	508	5	5	3
24	610	7	5	3
30	762	9	6	4
32	813	9	7	4
36	914	9	7	4
42	1067	11	8	5
48	1219	13	9	5
54	1372	15	10	6
60	1524	15	11	6
72	1829	19	13	7
84	2134	21	15	8
96	2438	25	17	9
120	3048	31	21	11
144	3658	37	25	13
For Other Widths, Use Odd Number of Sprockets ^d at Maximum 4 in. (102 mm) \varnothing Spacing		Maximum 6 in. (152 mm) \varnothing Spacing	Maximum 12 in. (305 mm) \varnothing Spacing	

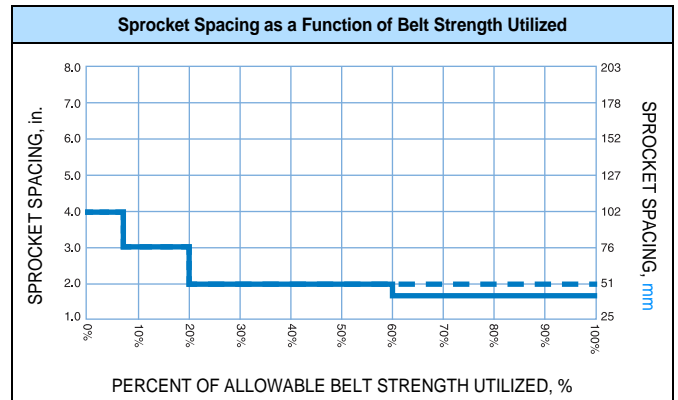
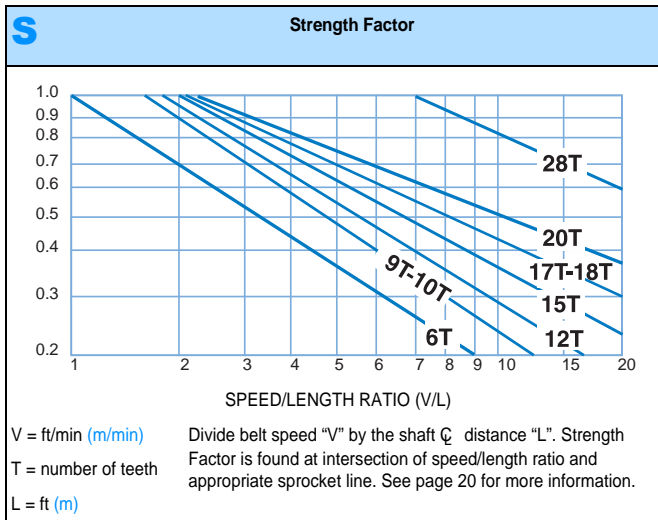
- a. If your belt width exceeds a number listed in the table, refer to the sprocket and support material minimums for the next larger width range listed. Belts are available in 0.33 in. (8.4 mm) increments beginning with minimum width of 2 in. (51 mm). **If the actual width is critical, contact Intralox Customer Service.**
- b. These are the minimum number of sprockets. Additional sprockets may be required for heavily loaded applications.
- c. Caution when using Friction Top. **Contact Intralox Customer Service for friction top applications.**
- d. The center sprocket should be locked down. With only two sprockets, fix the sprocket on the drive journal side only. See Retainer Rings/Center Sprocket Offset chart on page 410 for lock down location.



Molded Sprocket^a										
No. of Teeth (Chordal Action)	Nom. Pitch Dia. in	Nom. Pitch Dia. mm	Nom. Outer Dia. in	Nom. Outer Dia. mm	Nom. Hub Width in	Nom. Hub Width mm	Available Bore Sizes			
							U.S. Sizes		Metric Sizes	
							Round in ^b	Square in	Round mm ^b	Square mm
6 (13.40%)	2.1 ^c	53 ^c	2.2	56	0.75	19		1.0		25
9 (6.03%)	3.1	79	3.2	81	1.0	25	1	1.0	25	25
								1.5		40
10 (4.89%)	3.5	89	3.6	91	0.75	19		1.0		40
								1.5		
12 (3.41%)	4.1	104	4.3	109	1.5	38	1 to 1-1/2	1.5	25 to 40	40
							1-15/16 to 2-3/16		50 to 55	
17 (1.70%)	5.8	147	5.9	150	1.5	38	1-3/16 to 1-1/2		30 to 40	
18 (1.52%)	6.1	155	6.3	160	1.5	38	1 to 1-1/2	1.5	25 to 40	40
							1-15/16	2.5	50 to 55	60
							1.0	25	2-3/16	65
20 (1.23%)	6.8	173	7.0	178	1.5	38	1 to 1-1/2	1.5	25 to 40	40
							1-15/16 to 2-3/16	2.5	50 to 55	60
										65

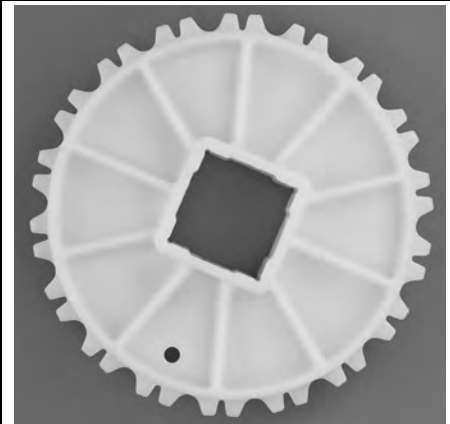

- a. Contact Customer Service for lead times. When using polyurethane sprockets, the Belt Strength for belts rated over 650 lb/ft (967 kg/m) will be de-rated to 650 lb/ft (967 kg/m) when using 1.5" (40 mm) bore sprockets and belt rated over 1,100 lb/ft (1,637 kg/m) will be de-rated to 1,100 lb/ft (1,637 kg/m) when using 2.5" (60 mm) bore sprockets. All other belts will maintain their published rating. The temperature range for Polyurethane sprockets is 0° F (-18 °C) to 120 °F (49 °C). Contact Customer Service for availability of polyurethane sprockets.
- b. Round bore molded and split sprockets are frequently furnished with two keyways. Use of two keys is NOT REQUIRED nor recommended. Round bore sprockets do not have set screws for locking the sprockets in place. As with square bore sprockets, only the center-most sprocket needs to be locked down. Imperial key sizes on round bore sprockets conform to ANSI standard B17.1-1967 (R1989) and metric key sizes conform to DIN standard 6885.
- c. See the Retaining Rings section for more information on retaining the 2.1 in (53 mm) pitch diameter sprocket.

EZ Clean™ Sprocket^a										
No. of Teeth (Chordal Action)	Nom. Pitch Dia. in	Nom. Pitch Dia. mm	Nom. Outer Dia. in	Nom. Outer Dia. mm	Nom. Hub Width in	Nom. Hub Width mm	Available Bore Sizes			
							U.S. Sizes		Metric Sizes	
							Round in ^b	Square in	Round mm ^b	Square mm
12 (3.41%)	4.1	104	4.3	109	1.5	38		1.5		40
18 (1.52%)	6.1	155	6.3	160	1.5	38		1.5		40



- a. Contact Customer Service for lead times. When using polyurethane sprockets, the Belt Strength for belts rated over 650 lb/ft (967 kg/m) will be de-rated to 650 lb/ft (967 kg/m) when using 1.5" (40 mm) bore sprockets and belt rated over 1,100 lb/ft (1,637 kg/m) will be de-rated to 1,100 lb/ft (1,637 kg/m) when using 2.5" (60 mm) bore sprockets. All other belts will maintain their published rating. The temperature range for polyurethane sprockets is 0° F (-18 °C) to 120 °F (49 °C). Contact Customer Service for availability of polyurethane sprockets.
- b. Round bore molded and split sprockets are frequently furnished with two keyways. Use of two keys is NOT REQUIRED nor recommended. Round bore sprockets do not have set screws for locking the sprockets in place. As with square bore sprockets, only the center-most sprocket needs to be locked down. Imperial key sizes on round bore sprockets conform to ANSI standard B17.1-1967 (R1989) and metric key sizes conform to DIN standard 6885.

Split Metal Sprocket^a

No. of Teeth (Chordal Action)	Nom. Pitch Dia. in	Nom. Pitch Dia. mm	Nom. Outer Dia. in	Nom. Outer Dia. mm	Nom. Hub Width in	Nom. Hub Width mm	Available Bore Sizes			
							U.S. Sizes		Metric Sizes	
							Round in ^b	Square in	Round mm ^b	Square mm
10 (4.89%)	3.5	89	3.6	91	1.5	38		1.5		40
12 (3.41%)	4.1	104	4.3	109	1.5	38		1.5		40
15 (2.19%)	5.1	130	5.3	135	1.5	38	1-3/16	1.5		
							1-1/4			
17 (1.70%)	5.8	147	6.1	155	1.5	38			40	40
18 (1.52%)	6.1	155	6.3	160	1.5	38	1-1/4	1.5		40
							1-1/2			2.5
20 (1.23%)	6.8	173	7.0	178	1.5	38	1-1/4	1.5		40
										2.5
28 ^c (0.63%)	9.8	249	10.0	254	1.5	38		1.5		40
								2.5		60

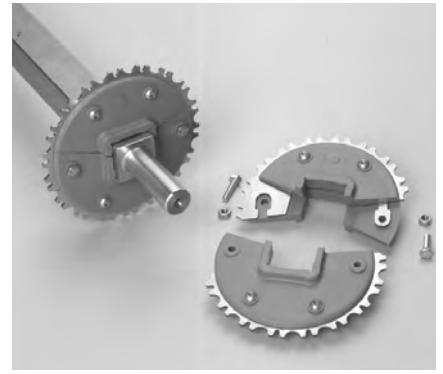

a. **Contact Customer Service for lead times.**

b. Round bore molded and split sprockets are frequently furnished with two keyways. Use of two keys is NOT REQUIRED nor recommended. Round bore sprockets do not have set screws for locking the sprockets in place. As with square bore sprockets, only the center-most sprocket needs to be locked down. Imperial key sizes on round bore sprockets conform to ANSI standard B17.1-1967 (R1989) and metric key sizes conform to DIN standard 6885.

c. The 9.8 in (249 mm) Pitch Diameter 28 tooth split sprocket should not be used with any Series 900 style acetal belt. A special 9.7 in (246 mm) Pitch Diameter split sprocket must be used instead. Contact Customer Service for lead times.

Split Metal with Polyurethane (FDA) Joining Plates Reduced Clearance Sprocket^a

No. of Teeth (Chordal Action)	Nom. Pitch Dia. in	Nom. Pitch Dia. mm	Nom. Outer Dia. in	Nom. Outer Dia. mm	Nom. Hub Width in	Nom. Hub Width mm	Available Bore Sizes			
							U.S. Sizes		Metric Sizes	
							Round in ^b	Square in	Round mm ^b	Square mm
15 (2.19%)	5.1	130	5.3	135	1.5	38		1.5		40
17 (1.70%)	5.8	147	6.1	155	1.5	38				40
18 (1.52%)	6.1	155	6.3	160	1.5	38		1.5		40
								2.5		60
20 (1.23%)	6.8	173	7.0	178	1.5	38		1.5		40
								2.5		
28 ^c (0.63%)	9.8	249	10.0	254	1.5	38		2.5		60



a. **Contact Customer Service for lead times.**

b. Round bore molded and split sprockets are frequently furnished with two keyways. Use of two keys is NOT REQUIRED nor recommended. Round bore sprockets do not have set screws for locking the sprockets in place. As with square bore sprockets, only the center-most sprocket needs to be locked down. Imperial key sizes on round bore sprockets conform to ANSI standard B17.1-1967 (R1989) and metric key sizes conform to DIN standard 6885.

c. The 9.8 in (249 mm) Pitch Diameter 28 tooth split sprocket should not be used with any Series 900 style acetal belt. A special 9.7 in (246 mm) Pitch Diameter split sprocket must be used instead. Contact Customer Service for lead times.

Molded Tooth Plate Split Glass Filled Nylon Sprocket^a

No. of Teeth (Chordal Action)	Nom. Pitch Dia. in	Nom. Pitch Dia. mm	Nom. Outer Dia. in	Nom. Outer Dia. mm	Nom. Hub Width in	Nom. Hub Width mm	Available Bore Sizes			
							U.S. Sizes		Metric Sizes	
							Round in ^b	Square in	Round mm ^b	Square mm
15 (2.19%)	5.1	130	5.3	135	1.5	38	1	1.5	30	40
							1-3/16		40	
17 (1.70%)	5.8	147	6.1	155	1.5	38			30	40
									40	
18 (1.52%)	6.1	155	6.3	160	1.5	38	1-1/4	1.5		40
							1-1/2		2.5	
20 (1.23%)	6.8	173	7.0	178	1.5	38	1-1/4	1.5		40
								2.5		60

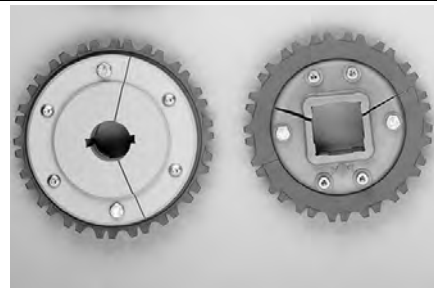

- a. **Contact Customer Service for lead times.**
- b. Round bore molded and split sprockets are frequently furnished with two keyways. Use of two keys is NOT REQUIRED nor recommended. Round bore sprockets do not have set screws for locking the sprockets in place. As with square bore sprockets, only the center-most sprocket needs to be locked down. Imperial key sizes on round bore sprockets conform to ANSI standard B17.1-1967 (R1989) and metric key sizes conform to DIN standard 6885.

Flat Top Base Flights (Streamline)

Available Flight Height		Available Materials
in	mm	
1	25	Polypropylene, Polyethylene, Acetal
2	51	
3	76	

Note: Flights can be cut down to custom heights with a minimum height of 0.25 in (13 mm).

Note: Each flight rises out of the center of its supporting module, molded as an integral part. No fasteners are required.

Note: Flat Top flight is smooth (Streamline) on both sides.

Note: The minimum indent (without sideguards) is 0.7 in (17.8 mm).

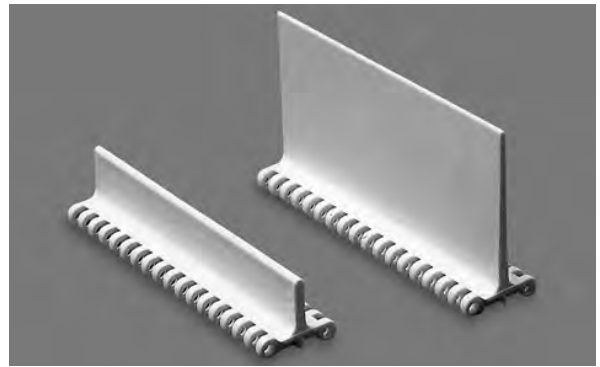

Flush Grid Nub Top Base Flight (Double No-Cling)

Available Flight Height		Available Materials
in	mm	
4	102	Polypropylene, Acetal

Note: Flights can be cut down to custom heights with a minimum height of 0.25 in (13 mm).

Note: Each flight rises out of the center of its supporting module, molded as an integral part. No fasteners are required.

Note: No-Cling vertical ribs are on both sides of the flight.

Note: The minimum indent (without sideguards) is 0.7 in (17.8 mm).

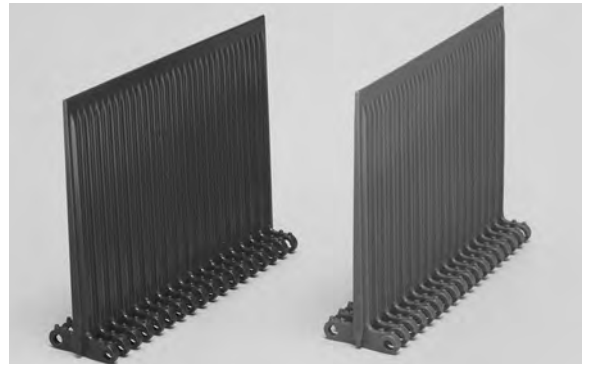

Flush Grid Base Flights (Streamline/No-Cling)

Available Flight Height		Available Materials
in	mm	
1	25	Polypropylene, Polyethylene, Acetal, HR HHR Nylon, HR Nylon ^a , Detectable Polypropylene ^b
2	51	

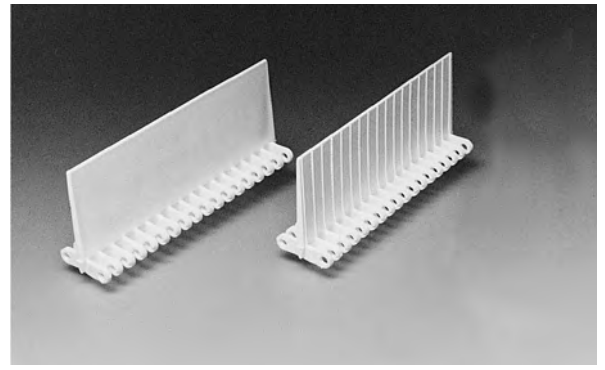

Note: Flights can be cut down to custom heights with a minimum height of 0.25 in (13 mm).

Note: Each flight rises out of the center of its supporting module, molded as an integral part. No fasteners are required.

Note: One side of the Flush Grid flight is smooth (Streamline) while the other is ribbed vertically (No-Cling).

Note: The minimum indent (without sideguards) is 0.7 in (17.8 mm).

- This product may not be used for food contact articles that will come in contact with food containing alcohol.
- Detectable Polypropylene can be sensed with metal detection equipment. Testing the material on a metal detector in a production environment is the best method for determining detection sensitivity.

Open Flush Grid Flush Edge Base Flights (No-Cling)

Available Flight Height		Available Materials
in	mm	
2	51	Polypropylene, Heat Resistant Nylon, High Heat Resistant Nylon



Note: Flights can be cut down to custom heights with a minimum height of 0.25 in (13 mm).

Note: Each flight rises out of the center of its supporting module, molded as an integral part. No fasteners are required.

Note: Flight is molded with a 1 in (25 mm) indent. Can be machined to any indent between 1 in (25 mm) and 3 in (76 mm).

Note: Flight is ribbed vertically (no-cling) on both sides.

Flat Top Base Flights (Streamline Rubber)

Available Flight Height		Available Materials
in	mm	
1	25	Polypropylene
2	51	
3	76	



Note: Each flight rises out of the center of its supporting module. No fasteners are required.

Note: 3 in (76 mm) flights are available in grey rubber only.

Note: Minimum indent (without sideguards) is 0.7 in (17.8 mm).

Note: Flights can be cut down to custom heights with a minimum height of 0.25 in (13 mm).

Note: Black rubber on grey PP flights (Restricted). White rubber on white PP flights (Restricted). Grey rubber on grey PP flights (Not Compliant).

Note: Black rubber flights have a hardness of 45 Shore A and White rubber flights have a hardness of 56 Shore A and grey rubber flights have a hardness of 85 Shore A.

Sideguards

Available Sizes		Available Materials
in	mm	
2	51	Polypropylene, Polyethylene, Acetal, HR Nylon ^a , HHR Nylon

Note: Sideguards have a standard overlapping design and are an integral part of the belt, with no fasteners required.

Note: The minimum indent is 1 in (25.4 mm). The standard gap between the sideguards and the edge of a flight is 0.2 in (5 mm).

Note: When going around the 6, 9, and 10 tooth sprockets, the sideguards will fan out, opening a gap at the top of the sideguard which might allow small products to fall out. The sideguards stay completely closed when wrapping around the 12 tooth and larger sprockets.

Note: Standard sideguard orientation is angled inward toward the product (product friendly). If needed, sideguards can be angled outward toward the conveyor.



a. This product may not be used for food contact articles that will come in contact with food containing alcohol.

Finger Transfer Plates

Available Widths		Number of Fingers	Available Materials
in	mm		
6	152	18	Acetal
4	102	12	

Note: Eliminates product transfer and tipping problems. The 18 fingers extend between the belt's ribs allowing a smooth continuation of the product flow as the belt engages its sprockets.

Note: Finger transfer plates are installed easily on the conveyor frame with the shoulder bolts supplied. Caps snap easily into place over the bolts, keeping foreign materials out of the slots.

Note: 4 in (102 mm) (12 finger) are for use only when retrofitting from Series 100 Raised Rib to Series 900 Raised Rib. The 4 in (102 mm) wide cannot be mixed with the 6 in (152 mm) wide finger plates.

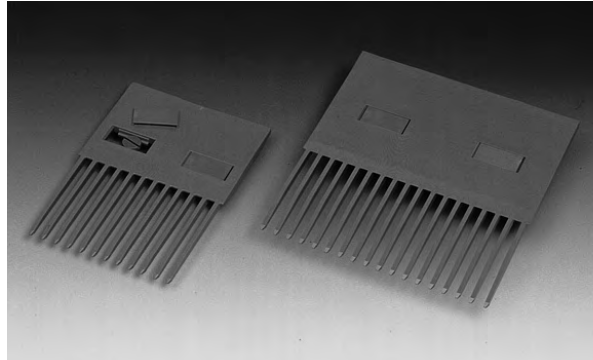

Hold Down Tabs

Available Clearance		Available Materials
in	mm	
0.16	4.1	Acetal
0.35	8.9	

Note: The 0.16 in (4.1 mm) tab is available in both Flat Top and Flush Grid styles. The 0.35 in (8.9 mm) tab is available with a Flat Top style. The top of this tab sits 0.04 in below the top of Flat Top belts and is level with the top of Flush Grid belts.

Note: Tabs are 1.4 in (36 mm) wide.

Note: Tabs are placed on every other row.

Note: Minimum indent is 0.7 in (17.8 mm).

Note: A minimum of 2.7 in (69 mm) is required between tabs to accommodate 1 sprocket.

Note: Carryway wearstrip or rollers that engage the tabs are only required at the transition between horizontal sections and angled sections. A carryway radius should be designed at this transition.

Note: Care should be taken to ensure that adequate lead-in radii and/or angles are used to prevent the possibility of snagging the tab on the frame.

Note: Hold down tabs do not work with 2.1 in (53 mm) and 3.1 in (79 mm) Pitch Diameter sprockets. 3.5 in (89 mm) Pitch Diameter sprockets may be used with a 1.5 in (40 mm) square bore.



Conveyor Frame Dimensions

Regardless of type or configuration, all conveyors using Intralox belts have some basic dimensional requirements. Specifically, dimensions "A", "B", "C" and "E" listed below should be implemented in any design.

For general applications and applications where end transfer of tip-sensitive product is not critical, use the "A" dimension at the bottom of the range.

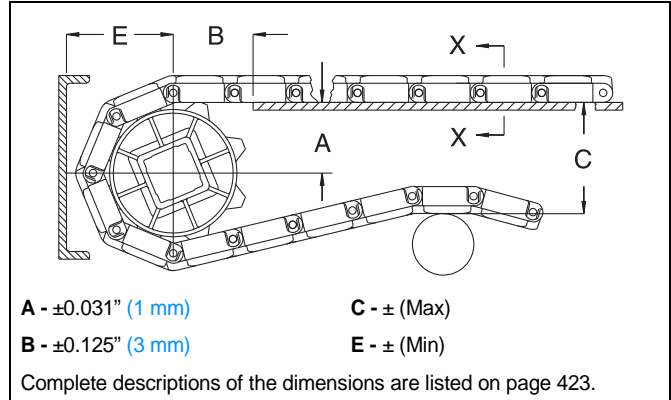

Sprocket Description		A		B		C		E		
Pitch Diameter		No. Teeth	Range (Bottom to Top)		in.	mm	in.	mm	in.	mm
in.	mm		in.	mm						
SERIES 900 FLUSH GRID, FLAT TOP, PERFORATED FLAT TOP, MESH TOP, NUB TOP^a										
2.1	53	6	0.75-0.90	19-23	1.25	32	2.28	58	1.51	38
3.1	79	9	1.30-1.39	33-35	1.51	38	3.20	81	1.75	44
3.5	89	10	1.47-1.56	37-40	1.70	43	3.60	91	2.01	51
4.1	104	12	1.82-1.90	46-48	1.74	44	4.25	108	2.51	64
5.1	130	15	2.34-2.40	60-61	2.00	51	5.20	132	2.77	70
5.8	147	17	2.69-2.74	68-70	2.13	54	5.80	147	3.15	80
6.1	155	18	2.86-2.91	73-74	2.20	56	6.20	155	3.30	84
6.8	173	20	3.21-3.25	81-82	2.32	59	6.75	171	3.86	98
9.8	249	28	4.58	116	2.96	75	9.70	246	5.02	128
SERIES 900 FLUSH GRID NUB TOP^a										
2.1	53	6	0.75-0.90	19-23	1.22	31	2.19	56	1.35	34
3.1	79	9	1.30-1.39	33-35	1.52	39	3.17	81	1.85	47
3.5	89	10	1.47-1.56	37-40	1.64	42	3.51	89	2.02	51
4.1	104	12	1.82-1.90	46-48	1.75	44	4.19	106	2.35	60
5.1	130	15	2.34-2.40	59-61	1.95	50	5.19	132	2.86	73
5.8	147	17	2.69-2.74	68-70	2.09	53	5.87	149	3.20	81
6.1	155	18	2.86-2.91	73-74	2.12	54	6.21	158	3.37	86
6.8	173	20	3.21-3.25	82-83	2.25	57	6.89	175	3.70	94
9.8	249	28	4.58	116	2.92	74	9.61	244	5.06	129
SERIES 900 RAISED RIB, FLUSH GRID WITH INSERT ROLLERS, OPEN GRID^a										
2.1	53	6	0.75-0.90	19-23	1.25	32	2.28	58	1.73	44
3.1	79	9	1.30-1.39	33-35	1.51	38	3.20	81	1.97	50
3.5	89	10	1.47-1.56	37-40	1.70	43	3.60	91	2.23	57
4.1	104	12	1.82-1.90	46-48	1.74	44	4.25	108	2.73	69
5.1	130	15	2.34-2.40	60-61	2.00	51	5.20	132	2.99	76
5.8	147	17	2.69-2.74	68-70	2.13	54	6.00	152	3.40	86
6.1	155	18	2.86-2.91	73-74	2.20	56	6.20	157	3.52	89

Sprocket Description		A		B		C		E		
Pitch Diameter		No. Teeth	Range (Bottom to Top)		in.	mm	in.	mm	in.	mm
in.	mm		in.	mm						
6.8	173	20	3.21-3.25	81-82	2.32	59	6.75	171	4.08	104
9.8	249	28	4.58	116	2.96	75	9.70	246	5.24	133
SERIES 900 OPEN FLUSH GRID^a										
2.1	53	6	0.75-0.90	19-23	1.25	32	2.28	58	1.51	38
3.1	79	9	1.30-1.39	33-35	1.51	38	3.20	81	1.75	44
3.5	89	10	1.47-1.56	37-40	1.70	43	3.60	91	2.01	51
4.1	104	12	1.82-1.90	46-48	1.74	44	4.25	108	2.51	64
5.1	130	15	2.34-2.40	60-61	2.00	51	5.20	132	2.77	70
5.8	147	17	2.69-2.74	68-70	2.13	54	5.80	147	3.15	80
6.1	155	18	2.86-2.91	73-74	2.20	56	6.20	155	3.30	84
6.8	173	20	3.21-3.25	81-83	2.32	59	6.75	171	3.86	98
9.8	249	28	4.58	116	2.96	75	9.70	246	5.02	128
SERIES 900 DIAMOND FRICTION TOP, FLAT FRICTION TOP, SQUARE FRICTION TOP^a										
2.1	53	6	0.75-0.90	19-23	1.25	32	2.28	58	1.76	45
3.1	79	9	1.30-1.39	33-35	1.51	38	3.20	81	1.96	50
3.5	89	10	1.47-1.56	37-40	1.70	43	3.60	91	2.22	56
4.1	104	12	1.82-1.90	46-48	1.74	44	4.25	108	2.72	69
5.1	130	15	2.34-2.40	60-61	2.00	51	5.20	132	2.98	76
5.8	147	17	2.69-2.74	68-70	2.13	54	6.00	152	3.40	86
6.1	155	18	2.86-2.91	73-74	2.20	56	6.20	157	3.51	89
6.8	173	20	3.21-3.25	81-82	2.32	59	6.75	171	4.08	104
9.8 ^b	249	28	4.58	116	2.96	75	9.70	246	5.23	133
SERIES 900 MOLD TO WIDTH 29 MM SQUARE FRICTION TOP^a										
2.1	53	6	0.75-0.90	19-23	1.27	32	2.38	60	1.54	39
3.1	79	9	1.30-1.39	33-35	1.58	40	3.36	85	2.04	52
3.5	89	10	1.47-1.56	37-40	1.70	43	3.70	94	2.21	56
4.1	104	12	1.82-1.90	46-48	1.88	48	4.38	111	2.54	65
5.1	130	15	2.34-2.40	59-61	2.10	53	5.38	137	3.05	77
5.8	147	17	2.69-2.74	68-70	2.32	59	6.06	154	3.39	86
6.1	155	18	2.83-2.88	72-73	2.31	59	6.34	161	3.52	89
6.8	173	20	3.21-3.25	82-83	2.42	61	7.08	180	3.89	99
9.8	249	28	4.58-4.61	116-117	2.92	74	9.80	249	5.25	133

a. Refer to "Anti-sag carryway wearstrip configuration" (page 428), for alternative layouts for the "B" dimension.

b. The 9.8 in. (249 mm) Pitch Diameter 28 tooth Split Sprocket should not be used with any Series 900 style Acetal Belt. A special 9.7 in (246 mm) Pitch Diameter Split Sprocket must be used instead.

Dead Plate Gap

Where there is a transfer point from a belt without finger transfer plates to a dead plate, there should be a gap between the surfaces to allow for the chordal action of the belt. As the belt engages its sprockets, chordal action causes the modules to move past a *fixed* point (the tip of the dead plate) with *varying* clearances. The table below shows the minimum amount of gap which occurs at the “low point” of the modules if the tip of the dead plate just comes in contact with the “high point” as the modules pass.

In some installations it may be desirable to keep the tip of the dead plate in contact with the belt, rather than allow a gap to occur. This can be done by hinging the mounting bracket for the dead plate. This allows the dead plate to move as the modules pass, but results in a small oscillating motion which may present tippage problems for sensitive containers or products.

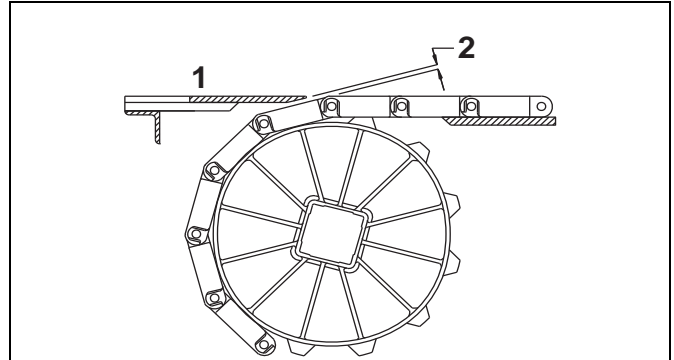

1 - Top surface of dead plate 2 - Dead plate gap

Note: The top surface of the dead plate is typically 0.031 in. (0.8 mm) above the belt surface for product transfer onto the belt, and 0.031 in. (0.8 mm) below the belt surface for product transfer off the belt.

Sprocket Description		Gap		
Pitch Diameter		No. Teeth	in.	mm
in.	mm			
2.1	53	6	0.147	3.7
3.1	79	9	0.095	2.4
3.5	89	10	0.084	2.1
4.1	104	12	0.071	1.8
5.1	130	15	0.057	1.4
5.8	147	17	0.050	1.3
6.1	155	18	0.047	1.2
6.8	173	20	0.042	1.1
9.8	249	28	0.029	0.7

Flat Top		
	in	mm
Pitch	0.60	15.2
Minimum Width	3	76
Width Increments	0.50	12.7
Opening Sizes (approx.)	-	-
Open Area	0%	
Hinge Style	Closed	
Drive Method	Center/Hinge-Driven	
Product Notes		
<ul style="list-style-type: none"> • Contact Intralox for precise belt measurements and stock status before designing equipment or ordering a belt. • Smooth, closed upper surface with fully flush edges. • Uses headed rods. • Underside design and small pitch allow the belt to run smoothly around nosebars. • Can be used over 0.75 in (19.1 mm) diameter nosebars for tight transfers. • Mini-pitch reduces chordal action and transfer dead plate gap. • Minimal back tension required. • Closed edges on one side of the belt. • Lug tooth sprockets improve sprocket engagement and make installation easier. 		
Additional Information		
<ul style="list-style-type: none"> • See "Belt Selection Process" (page 5) • See "Standard Belt Materials" (page 9) • See "Special Application Belt Materials" (page 9) • See "Friction Factors" (page 13) 		

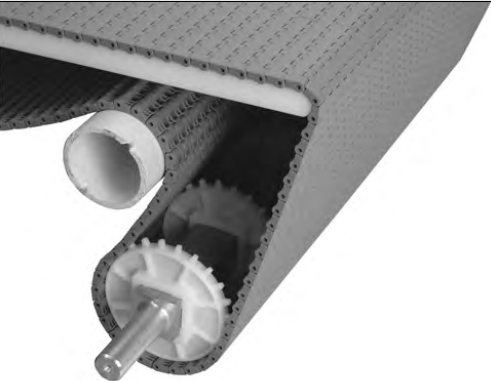
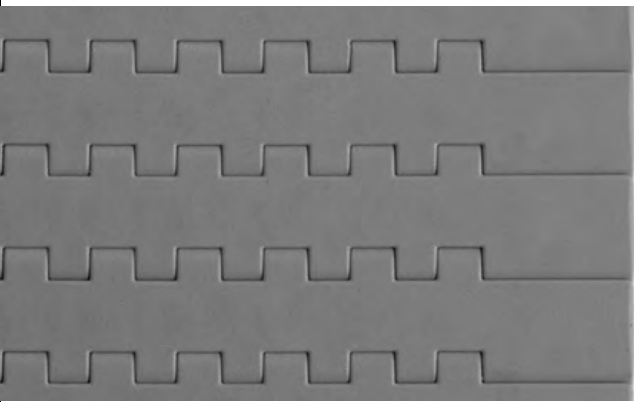
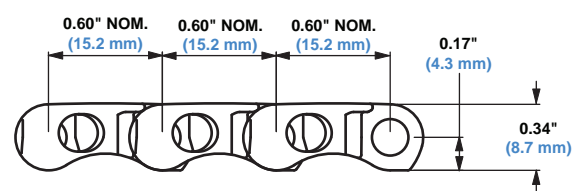
Belt Data							
Belt Material	Standard Rod Material Ø 0.18 in (4.6 mm)	BS Belt Strength		Temperature Range (continuous)		W Belt Weight	
		lb/ft	kg/m	°F	°C	lb/ft ²	kg/m ²
Acetal	Polypropylene	1500	2232	34 to 200	1 to 93	1.55	7.57
Polypropylene	Polypropylene	1000	1490	34 to 220	1 to 104	1.07	5.22
Polyethylene	Polyethylene	600	893	-50 to 150	-46 to 66	1.11	5.42
HR Nylon	Nylon	1000	1490	-50 to 240	-46 to 116	1.31	6.43

Insert Roller

	in	mm
Pitch	0.60	15.2
Minimum Width	6	152
Width Increments	3.00	76
Open Area	12.5%	
Hinge Style	Closed	
Drive Method	Center/Hinge-Driven	



Product Notes

- **Contact Intralox for precise belt measurements and stock status before designing equipment or ordering a belt.**
- Yellow acetal rollers are 0.3 in (7.6 mm) wide and 0.48 in (12.1 mm) diameter and are located on the belt rod.
- Roller density is 240 rollers/ft² (2580 rollers/m²).
- Rollers protrude above and below the belt surfaces.
- Rollers are spaced in groups with 1.5 in (38.1 mm) between roller zones.
- For low back pressure applications, place wearstrip between rollers. For activated roller applications, place wearstrip directly under rollers.
- Compatible with 0.75 in (19.1 mm) diameter notched nosebars for tight transfers. Contact Intralox Customer Service for more information.
- Belt can be supported using 1.38 in (35.1 mm) wide or narrower parallel wearstrips.
- Sprocket locations are indented 1.5 in (38.1 mm) from edge of belt.
- Sprocket locations are spaced 3.0 in (76.2 mm) apart.
- Roller indent from edge of belt to edge of roller is 2.25 in (57.2 mm).
- Minimal back tension required.
- Fully flush edges on one side and closed edges on opposite side.
- Uses headless rods.
- 6 in (152 mm) belt is Mold-To-Width with 0.44 in (11.2 mm) roller indent.
- Belt widths above 6 in (152 mm) are bricklaid.

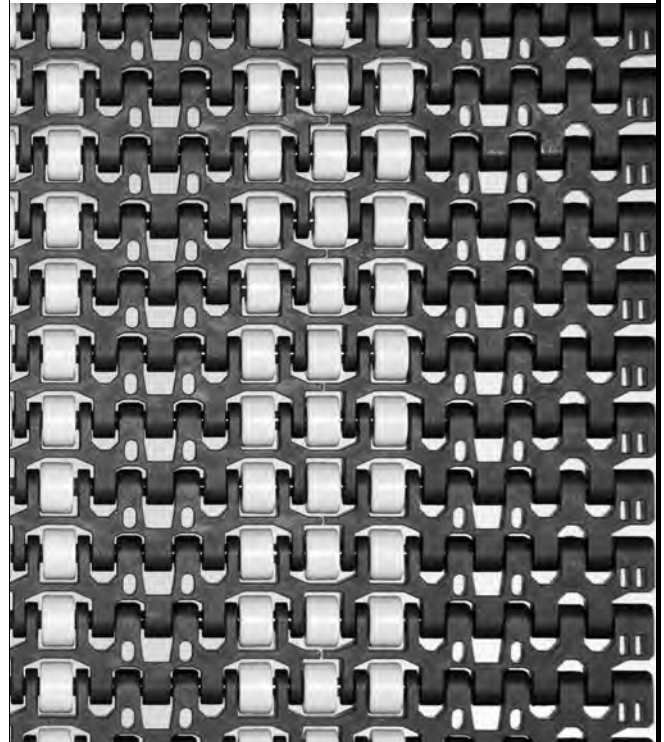

Additional Information

- See "Belt Selection Process" (page 5)
- See "Standard Belt Materials" (page 9)
- See "Special Application Belt Materials" (page 9)
- See "Friction Factors" (page 13)

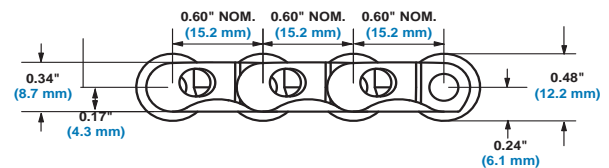

Belt Data

Belt Material	Standard Rod Material Ø 0.18 in (4.6 mm)	BS Belt Strength		Temperature Range (continuous)		W Belt Weight	
		lb/ft	kg/m	°F	°C	lb/ft ²	kg/m ²
Acetal	Nylon	1000	1490	-50 to 200	-46 to 93	1.7	8.3

High Density Insert Roller

	in	mm
Pitch	0.6	15.2
Minimum Width	9	229
Width Increments	3.00	76.2
Open Area	4%	
Hinge Style	Closed	
Drive Method	Center/Hinge-driven	

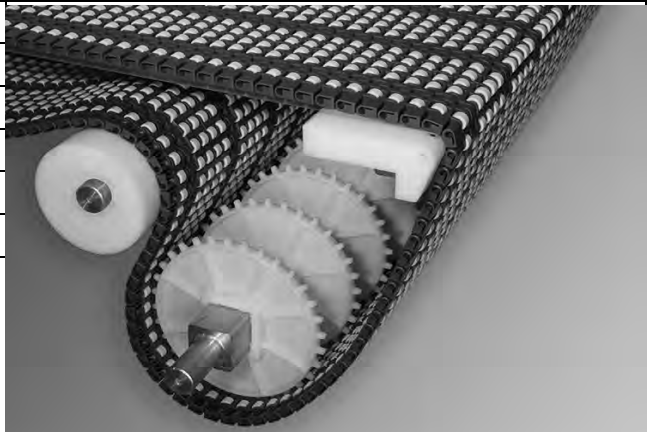

Product Notes

- **Contact Intralox for precise belt measurements and stock status before designing equipment or ordering a belt.**
- Uses single headless rod across the entire belt width on each row of belt.
- Yellow acetal rollers are 0.30 in (7.6 mm) wide and 0.48 in (12.1 mm) diameter, and are located on the belt rod. Rollers protrude above and below the belt surfaces.
- Roller density is 320 rollers/ft² (3440 rollers/m²).
- For low back pressure applications, place wearstrip between rollers in parallel. Wearstrip of 0.50 in (13 mm) wide is recommended to allow some manufacturing and installation tolerance in the conveyor, while providing adequate support to the belt. Maximum allowed wearstrip width is 0.75 in (19 mm).
- For activated roller applications, place wearstrip directly under rollers.
- Compatible with 0.75 in (19.1 mm) diameter nosebars for tight transfers. For high-speed and load applications, a nose-roller is recommended.
- Sprocket locations are indented 1.5 in (38.1 mm) from edge of belt.
- Sprocket locations are spaced 3.0 in (76.2 mm) apart.
- Roller indent from edge of belt to edge of roller is 0.70 in (17.8 mm).
- Minimum back tension required.
- Fully flush edges on one side and closed edges on opposite side.

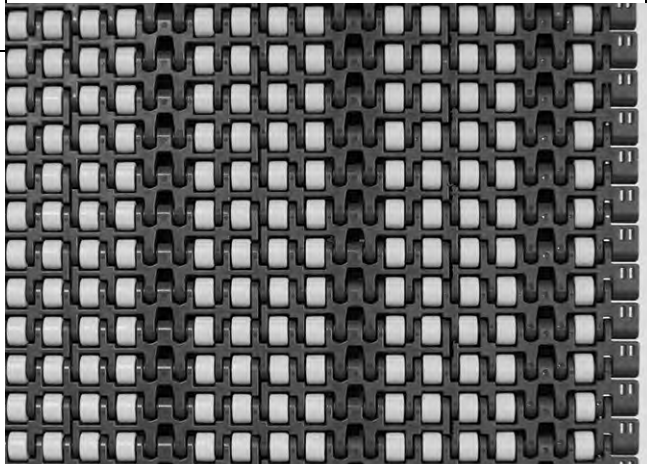

Additional Information

- See "Belt Selection Process" (page 5)
- See "Standard Belt Materials" (page 9)
- See "Special Application Belt Materials" (page 9)
- See "Friction Factors" (page 13)

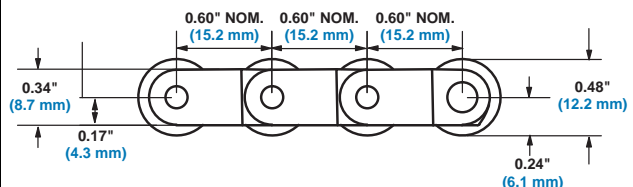

Belt Data

Belt Material	Standard Rod Material 0.25 x 0.17 in (6.4 x 4.3 mm)	BS Belt Strength		Temperature Range (continuous)		W Belt Weight	
		lb/ft	kg/m	°F	°C	lb/ft ²	kg/m ²
Acetal	Nylon	1000	1490	-50 to 200	-46 to 93	1.87	9.13

High Density Insert Roller 85 mm

	in	mm
Pitch	0.6	15.2
Minimum Width	10	255
Width Increments	3.35	85
Open Area	3.6%	
Hinge Style	Closed	
Drive Method	Center/Hinge-driven	

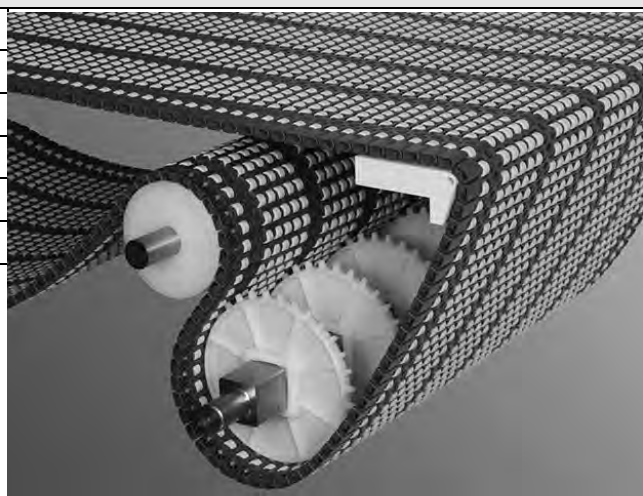

Product Notes

- **Contact Intralox for precise belt measurements and stock status before designing equipment or ordering a belt.**
- Uses single headless rod across the entire belt width on each row of belt.
- Yellow acetal rollers are 0.30 in (7.6 mm) wide and 0.48 in (12.1 mm) diameter, and are located on the belt rod. Rollers protrude above and below the belt surfaces.
- Roller density is 360 rollers/ft² (3875 rollers/m²).
- For low back pressure applications, place wearstrip between rollers in parallel. Wearstrip of 0.50 in (13 mm) wide is recommended to allow some manufacturing and installation tolerance in the conveyor, while providing adequate support to the belt. Maximum allowed wearstrip width is 0.75 in (19 mm).
- For activated roller applications, place wearstrip directly under rollers.
- Compatible with 0.75 in (19.1 mm) diameter nosebars for tight transfers. For high-speed and load applications, a nose-roller is recommended.
- Sprocket locations are indented 1.67 in (42.5 mm) from edge of belt.
- Sprocket locations are spaced 3.35 in (85 mm) apart.
- Roller indent from edge of belt to edge of roller is 0.89 in (22.6 mm).
- Minimum back tension required.
- Fully flush edges on one side and closed edges on opposite side.

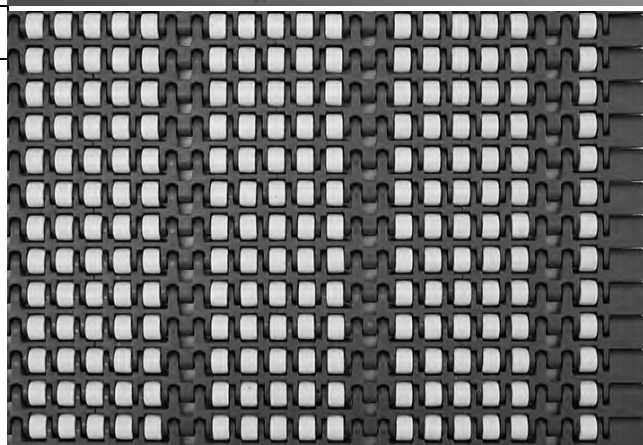

Additional Information

- See "Belt Selection Process" (page 5)
- See "Standard Belt Materials" (page 9)
- See "Special Application Belt Materials" (page 9)
- See "Friction Factors" (page 13)

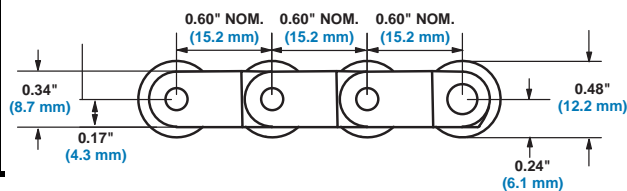

Belt Data

Belt Material	Standard Rod Material Ø 0.18 in (4.6 mm)	BS		Belt Strength		Temperature Range (continuous)		W		Belt Weight	
		lb/ft	kg/m	°F	°C	lb/ft ²	kg/m ²				
Acetal	Nylon	1000	1490	-50 to 200	-46 to 93	1.95	9.52				

Flat Friction Top 85 mm

	in	mm
Pitch	0.60	15.2
Minimum Width	3.35	85.0
Maximum Width	66.9	1700
Width Increments	3.35	85
Opening Sizes (approx.)	-	-
Open Area	0%	
Hinge Style	Closed	
Drive Method	Center/Hinge-driven	

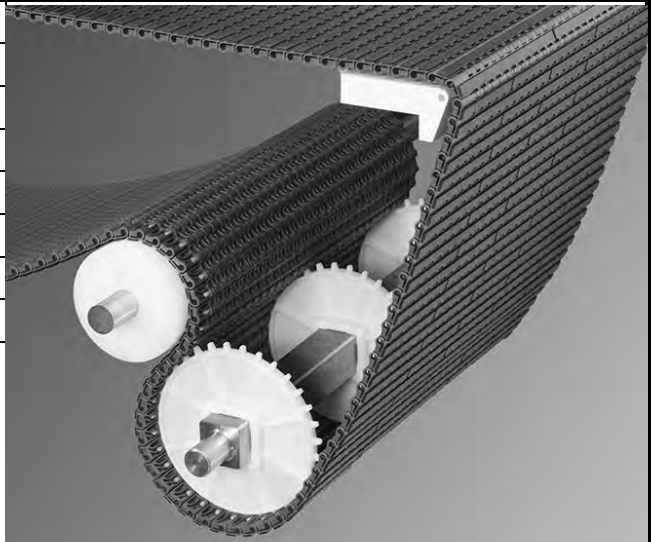

Product Notes

- **Contact Intralox for precise belt measurements and stock status before designing equipment or ordering a belt.**
- Uses headless rods.
- Smooth, closed upper surface with fully flush edges.
- Underside design combined with small pitch allow the belt to run smoothly around a 0.75 in (19 mm) nosebar. A dynamic nose-roller is highly recommended for package handling applications.
- Small pitch reduces chordal action, reducing the gap at transfer dead plate.
- Minimal back tension required to maintain sprocket engagement.
- Closed edges used on one side of the belt.
- Sprockets have lug tooth, which improves drive performance and enhances sprocket life.

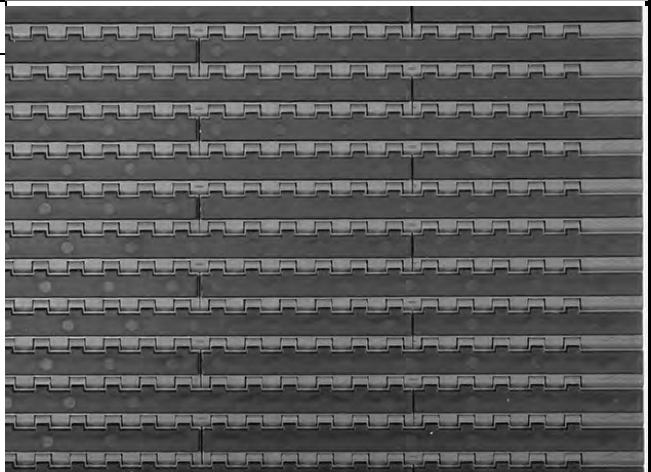

Additional Information

- See "Belt Selection Process" (page 5)
- See "Standard Belt Materials" (page 9)
- See "Special Application Belt Materials" (page 9)
- See "Friction Factors" (page 13)

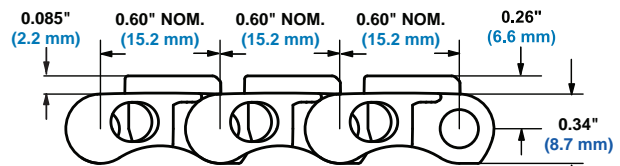

Belt Data

Base Belt Material	Base/Friction Color	Standard Rod Material Ø 0.18 in (4.6 mm)	BS Belt Strength		Temperature Range (continuous)		W Belt Weight		Friction Top Hardness	Agency Acceptability	
			lb/ft	kg/m	°F	°C	lb/ft ²	kg/m ²		FDA (USA)	EU MC ^b
Acetal	Grey/Black	Nylon	1500	2230	-10 to 130	-23 to 54	1.80	8.79	54 Shore A	•	

• - Fully compliant

a - FDA Compliant with Restriction: Do not use in direct contact with fatty foods.

b - European Migration Certificate providing approval for food contact according to EU Regulation 10/2011.

c - This elastomer is not subject to the testing of this directive.

Mold to Width Flat Top with Tabs

	in	mm
Pitch	0.60	15.2
Molded Widths	3.25	83
	3.35	85
	4.50	114
Opening Sizes (approx.)	-	-
Open Area	0%	
Hinge Style	Closed	
Drive Method	Center/Hinge-driven	

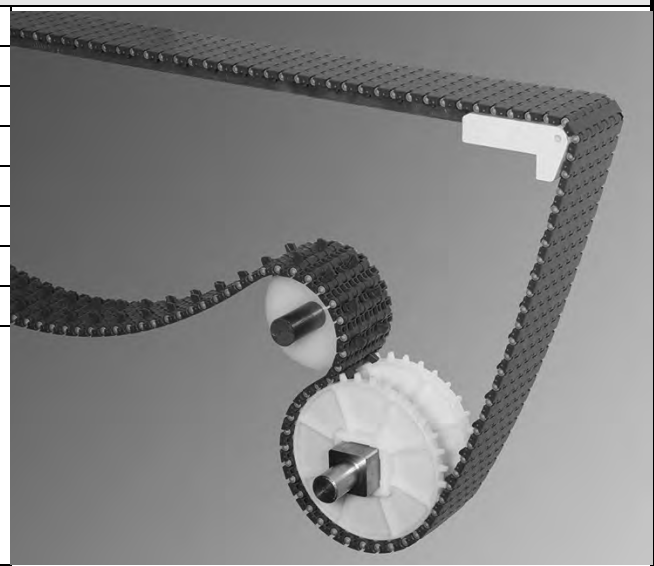

Product Notes

- Contact Intralox for precise belt measurements and stock status before designing equipment or ordering a belt.
- Series 1000 MTW Flat Top belts are boxed in 10 ft (3.05 m) increments.
- Smooth, closed upper surface with fully flush edges.
- Uses headed rods.
- Can be used over 0.75 in (19.1 mm) diameter nosebars for tight transfers.
- Minimal back tension required.
- Lug tooth sprockets improve sprocket engagement and make installation easier.
- 3.25 in (83 mm) tabbed belts use one sprocket.
- 4.50 in (114 mm) and 3.35 in (85 mm) tabbed belts use up to three sprockets.
- Width tolerances for Series 1000 MTW belts are +0.000/-0.020 in (+0.00/-0.50 mm).
- Tracking tabs provide lateral tracking.
- 3.35 in (85 mm) molded tracking tabs fit into standard 1-21/32 in (42.1 mm) wearstrip tracks ensuring proper belt alignment.
- 3.25 in (83 mm) and 4.50 in (114 mm) molded tracking tabs fit into standard 1-3/4 in (44.5 mm) wearstrip tracks ensuring proper belt alignment.

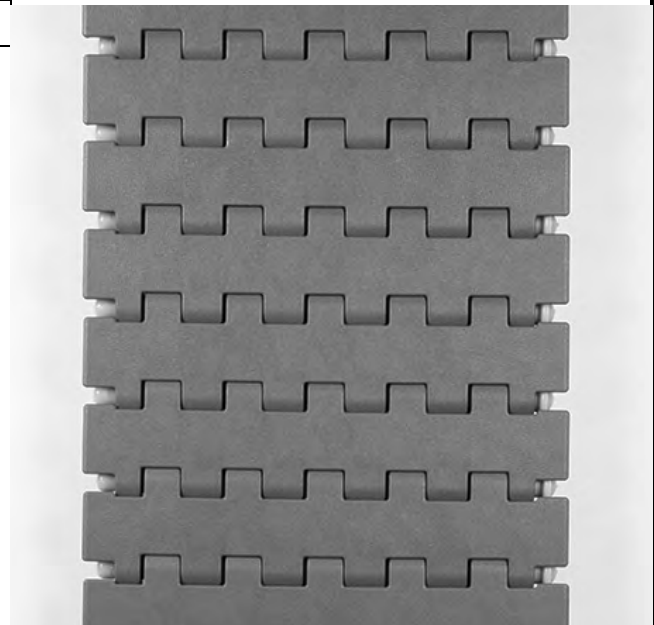

Additional Information

- See "Belt Selection Process" (page 5)
- See "Standard Belt Materials" (page 9)
- See "Special Application Belt Materials" (page 9)
- See "Friction Factors" (page 13)

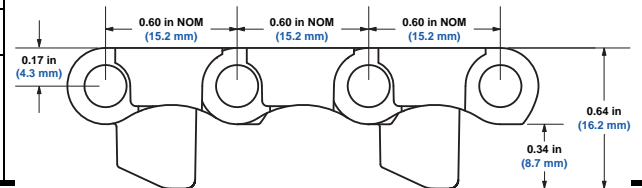

Belt Data

Belt Width		Belt Material	Standard Rod Material Ø 0.18 in (4.6 mm)	BS		Temperature Range (continuous)		W	
inch	(mm)			Belt Strength		°F	°C	Belt Weight	
				lb	kg			lb/ft	kg/m
3.25	83	Acetal	Nylon	406	600	-50 to 200	-46 to 93	0.44	0.65
3.35	85	Acetal	Nylon	419	620	-50 to 200	-46 to 93	0.44	0.65
4.50	114	Acetal	Nylon	563	840	-50 to 200	-46 to 93	0.60	0.89

Flat Top 85 mm

	in	mm
Pitch	0.6	15.2
Minimum Width	10	255
Maximum Width	67	1700
Width Increments	3.35	85
Opening Sizes (approx.)	-	-
Open Area	0%	
Hinge Style	Closed	
Drive Method	Center/Hinge-driven	

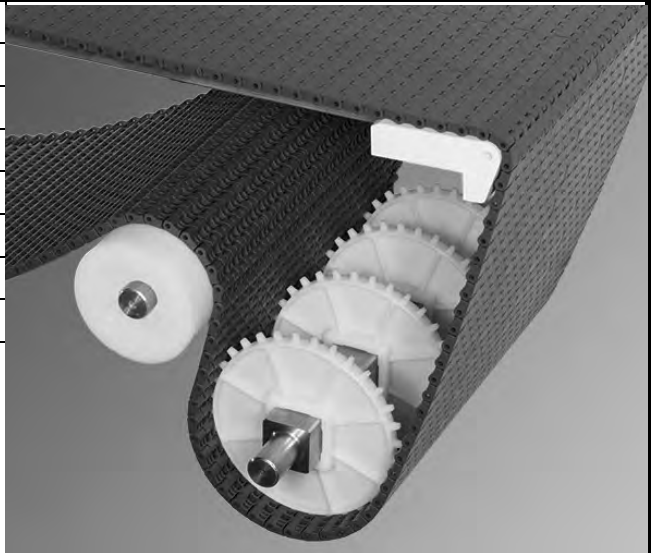

Product Notes

- **Contact Intralox for precise belt measurements and stock status before designing equipment or ordering a belt.**
- Uses headless rods.
- Smooth, closed upper surface with fully flush edges.
- Underside design combined with small pitch allow the belt to run smoothly around a 0.75 in (19 mm) nosebar. A dynamic nose-roller is highly recommended for package handling applications.
- Small pitch reduces chordal action, reducing the gap at transfer dead plate.
- Minimal back tension required to maintain sprocket engagement.
- Closed edges used on one side of the belt.
- Sprockets have lug tooth, which improves drive performance and enhances sprocket life.

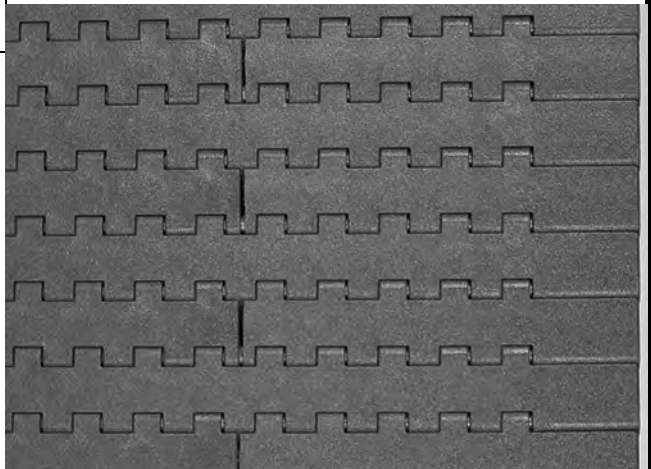

Additional Information

- See "Belt Selection Process" (page 5)
- See "Standard Belt Materials" (page 9)
- See "Special Application Belt Materials" (page 9)
- See "Friction Factors" (page 13)

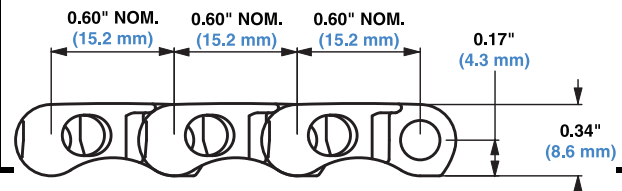

Belt Data

Belt Material	Standard Rod Material Ø 0.18 in (4.6 mm)	BS		Temperature Range (continuous)		W	
		Belt Strength		°F	°C	Belt Weight	
		lb/ft	kg/m			lb/ft ²	kg/m ²
Acetal	Polypropylene	1500	2230	34 to 200	1 to 93	1.55	7.57

Flat Top ONEPIECE™ Live Transfer 6.3 in

	in	mm
Pitch	.60	15.2
Molded Width	6.3	160
Width Increments	-	-
Open Area	0%	
Hinge Style	Closed	
Drive Method	Center/Hinge-driven	



Product Notes

- **Contact Intralox for precise belt measurements and stock status before designing equipment or ordering a belt.**
- Series 1000 MTW Flat Top belts are boxed in 10 ft (3.05 m) increments.
- Smooth, closed upper surface with fully flush edges. Uses headed rods.
- Transfer edge is an integral part of this belt.
- Cannot be used over 0.75 in (19.1 mm) diameter nosebars for tight transfers.
- Minimal back tension required.
- Lug-tooth sprockets improve sprocket engagement and make installation easier.
- Belt uses three sprockets.
- For information regarding sprocket placement, refer to the Center Sprocket Offset chart on page 408.
- Designed for smooth, self-clearing, right-angle transfers onto takeaway belts.
- Molded tracking tabs fit into standard 1.75 in (44.5 mm) wearstrip tracks to ensure proper belt alignment.
- You may need to include a fixed-frame support member beneath the ONEPIECE™ Live Transfer belt prior to the actual transfer. This ensures that the ONEPIECE™ Live Transfer belt does not snag when it intersects with the takeaway belt. See “Fig. 3–31 PARABOLIC GUIDE RAIL CONTOURS WITH 6.0 in. (152 mm) ONEPIECE™ LIVE TRANSFER BELT” (page 440).
- Use sprockets with a pitch diameter of 1.50 in (38.1 mm) or larger.

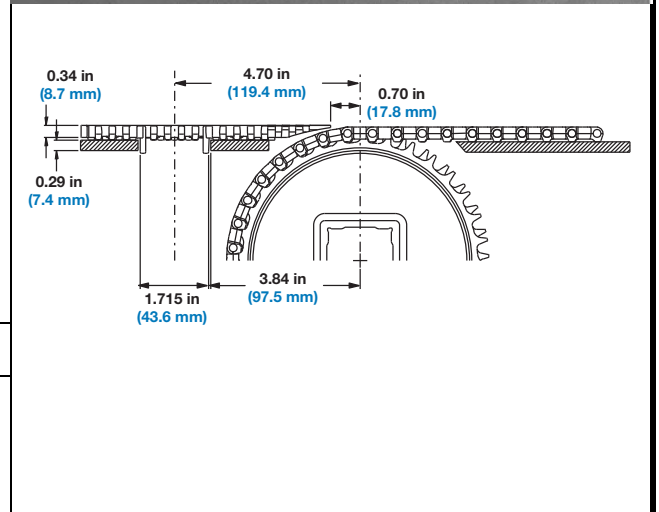
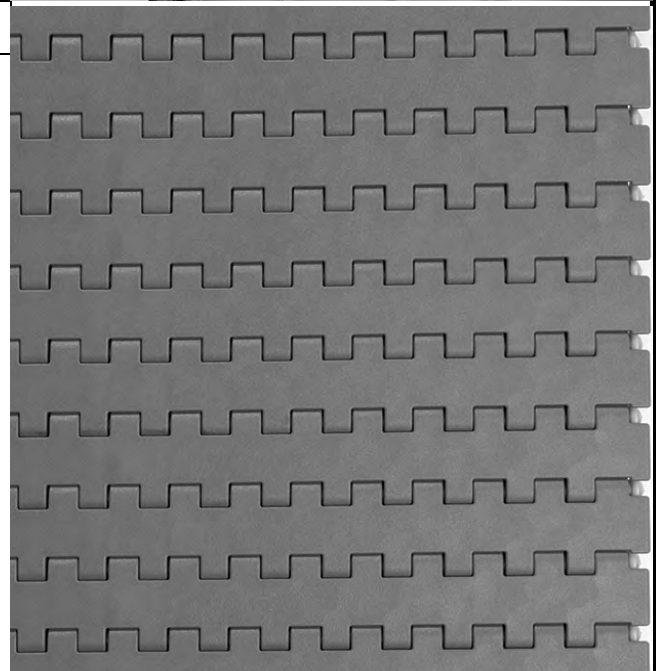

Additional Information

- See “Belt Selection Process” (page 5)
- See “Standard Belt Materials” (page 9)
- See “Special Application Belt Materials” (page 9)
- See “Friction Factors” (page 13)

Belt Data

Belt Material	Standard Rod Material 0.18 in (4.6 mm)	BS Belt Strength		Temperature Range (continuous)		W Belt Weight	
		lb/ft	kg/m	°F	°C	lb/ft ²	kg/m ²
Acetal	Nylon	500	744	-50 to 200	-46 to 93	0.78	3.81

Flat Friction Top		
	in	mm
Pitch	0.60	15.2
Minimum Width	3	76
Width Increments	0.5	12.7
Opening Sizes (approx.)	-	-
Open Area	0%	
Hinge Style	Closed	
Drive Method	Center/Hinge-Driven	
Product Notes		
<ul style="list-style-type: none"> • Contact Intralox for precise belt measurements and stock status before designing equipment or ordering a belt. • Smooth, closed upper surface with fully flush edges. • Uses headless rods. • Underside design and small pitch allow the belt to run smoothly around nosebars. • Can be used over 0.75 in (19.1 mm) diameter nosebars for tight transfers. • Available in grey acetal with black rubber. • Friction top extends to the edge of the belt (no indent). • Mini-pitch reduces chordal action and transfer dead plate gap. • Closed edges on one side of the belt. • Lug tooth sprockets improve sprocket engagement and make installation easier. 		
Additional Information		
<ul style="list-style-type: none"> • See "Belt Selection Process" (page 5) • See "Standard Belt Materials" (page 9) • See "Special Application Belt Materials" (page 9) • See "Friction Factors" (page 13) 		

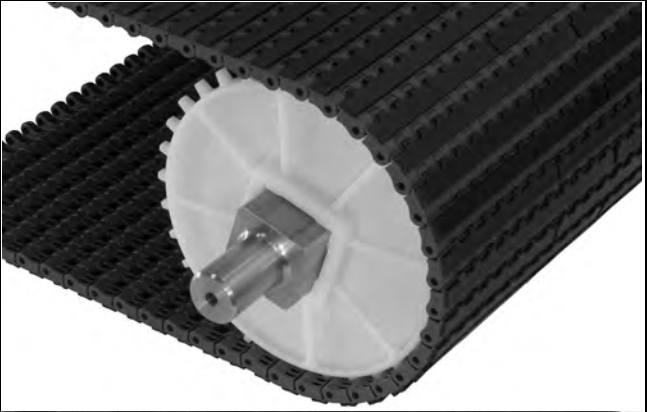
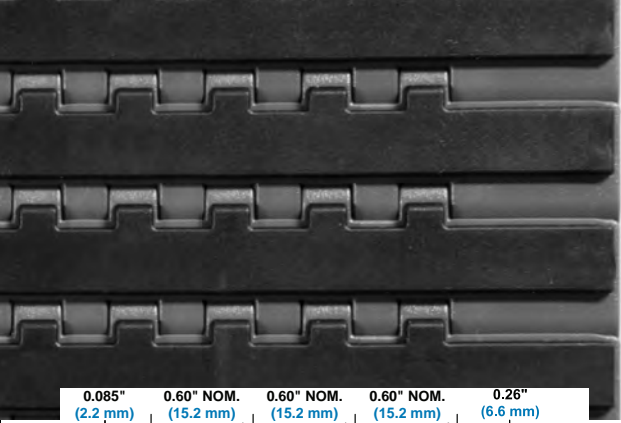
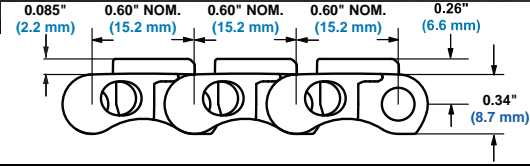
Belt Data												
Base Belt Material	Base/Friction Color	Standard Rod Material Ø 0.18 in (4.6 mm)	BS	Belt Strength		Temperature Range (continuous)		W		Friction Top Hardness	Agency Acceptability	
				lb/ft	kg/m	°F	°C	lb/ft ²	kg/m ²		FDA (USA)	EU MC ^b
Acetal	Grey/Black	Nylon		1500	2232	-10 to 130	-23 to 54	1.80	8.79	54 Shore A	•	
Acetal	White/White	Nylon		1500	2232	-10 to 130	-23 to 54	1.80	8.79	54 Shore A	•	

• - Fully compliant

a - FDA Compliant with Restriction: Do not use in direct contact with fatty foods.

b - European Migration Certificate providing approval for food contact according to EU Regulation 10/2011.

c - This elastomer is not subject to the testing of this directive.

Mold to Width Flat Top

	in	mm
Pitch	0.6	15.2
Molded Widths	1.1	29
	1.5	37
	1.8	46
	2.2	55
Opening Size (approximate)	-	-
Open Area	0%	
Hinge Style	Closed	
Drive Method	Center/Hinge-driven	



Product Notes

- Contact Intralox for precise belt measurements and stock status before designing equipment or ordering a belt.
- Series 1000 MTW Flat Top belts are boxed in 10 ft (3.05 m) increments.
- Smooth, closed upper surface with fully flush edges.
- Uses headless rods.
- Underside design and small pitch allow the belt to run smoothly around nosebars.
- Can be used over 0.75 in (19.1 mm) diameter nosebars for tight transfers.
- Minimal back tension required.
- Lug tooth sprockets improve sprocket engagement and make installation easier.
- 29 mm and 37 mm belts use one sprocket.
- 46 mm and 55 mm belts can use up to two sprockets.

Additional Information

- See "Belt Selection Process" (page 5)
- See "Standard Belt Materials" (page 9)
- See "Special Application Belt Materials" (page 9)
- See "Friction Factors" (page 13)

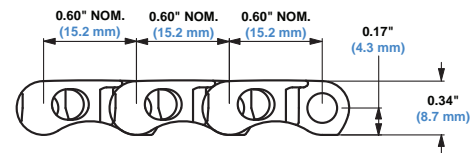

Belt Data

Belt Width		Belt Material	Standard Rod Material Ø 0.18 in (4.6 mm)	BS		Temperature Range (continuous)		W	
inch	(mm)			lb	kg	°F	°C	lb/ft	kg/m
1.1	29	Acetal	Nylon	140	64	-50 to 200	-46 to 93	0.15	0.22
1.5	37	Acetal	Nylon	200	91	-50 to 200	-46 to 93	0.19	0.28
1.8	46	Acetal	Nylon	230	104	-50 to 200	-46 to 93	0.23	0.35
2.2	55	Acetal	Nylon	200 ^a	91 ^a	-50 to 200	-46 to 93	0.28	0.42

a. 270 lb (122 kg) for 2.2 in (55 mm) with two (2) sprockets

Non Skid Raised Rib

	in	mm
Pitch	0.60	15.2
Minimum Width	3.0	76.0
Width Increments	0.5	12.7
Opening Sizes (approx.)	-	-
Open Area	0%	
Hinge Style	Closed	
Drive Method	Center/Hinge-Driven	

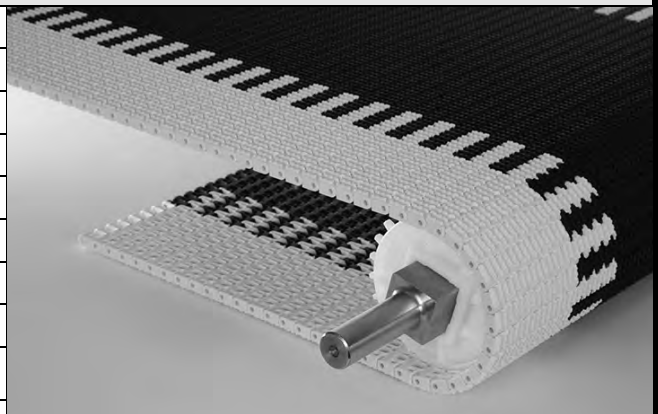

Product Notes

- **Contact Intralox for precise belt measurements and stock status before designing equipment or ordering a belt.**
- Mini-pitch reduces chordal action and transfer dead plate gap.
- Minimal back tension required.
- Closed edges on one side of the belt.
- Lug tooth sprockets improve sprocket engagement and make installation easier.
- Finger transfer plates ensure safe transfers, eliminating the need for safety stops and reducing downtime.
- Low profile conveyor reduces the installation costs associated with digging pits.
- Non Skid Raised Rib surface increases traction.
- Two edge options available: no indent and 21 mm indent.

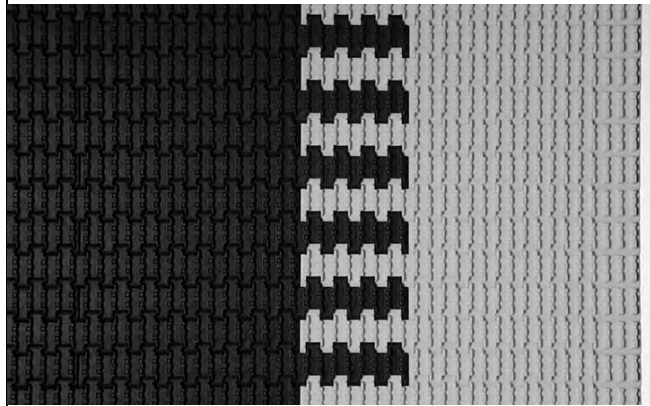

Additional Information

- See "Belt Selection Process" (page 5)
- See "Standard Belt Materials" (page 9)
- See "Special Application Belt Materials" (page 9)
- See "Friction Factors" (page 13)

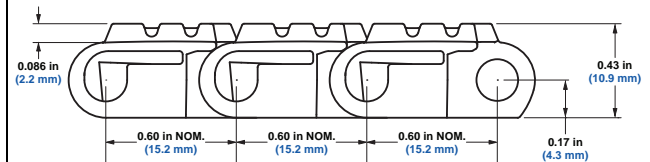

Belt Data

Belt Material	Standard Rod Material Ø 0.18 in (4.6 mm)	BS		Temperature Range (continuous)		W	Belt Weight
		lb/ft	kg/m	°F	°C		
Acetal	Nylon	2000	2976	-50 to 200	-46 to 93	1.86	9.08
HSEC Acetal	Nylon	1800	2679	-50 to 200	-46 to 93	1.88	9.18
FR Anti Static	Nylon	700	1042	-50 to 150	-46 to 66	1.64	8.01

Sprocket and Support Quantity Reference				
Belt Width Range ^a		Minimum Number of Sprockets Per Shaft ^b	Wearstrips	
in	mm		Carryway	Returnway ^c
3	76	2	2	2
4	102	2	2	2
6	152	2	2	2
7	178	2	3	2
8	203	2	3	2
10	254	2	3	2
12	305	3	3	2
14	356	3	4	3
15	381	3	4	3
18	457	3	4	3
24	610	5	5	3
30	762	5	6	4
36	914	7	7	4
42	1067	7	8	5
48	1219	9	9	5
54	1372	9	10	6
60	1524	11	11	6
72	1829	13	13	7
84	2134	15	15	8
96	2438	17	17	9
120	3048	21	21	11
144	3658	25	25	13
For Other Widths, Use Odd Number of Sprockets ^d at Maximum 6 in. (152 mm) \varnothing Spacing			Maximum 6 in. (152 mm) \varnothing Spacing	Maximum 12 in. (305 mm) \varnothing Spacing

- a. Belts are available in 0.5 in (12.7 mm) increments beginning with 3 in (76 mm). If the actual width is critical, consult Customer Service.
- b. These are the minimum number of sprockets. Additional sprockets may be required for heavily loaded applications.
- c. Caution when using Friction Top. Contact Intralox Customer Service for friction top applications.
- d. The center sprocket should be locked down. With only two sprockets, fix the sprocket on the drive journal side only.

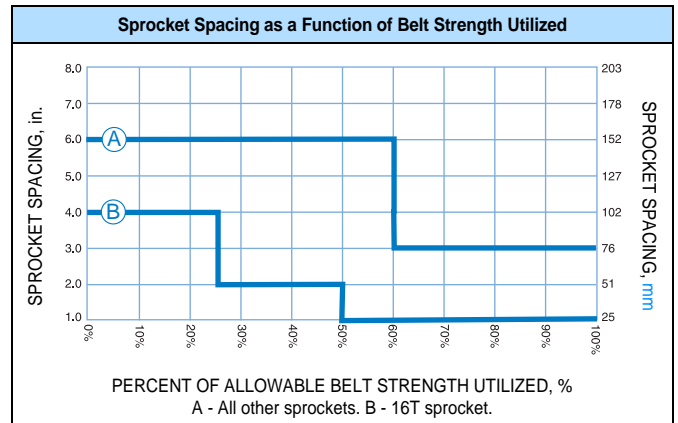
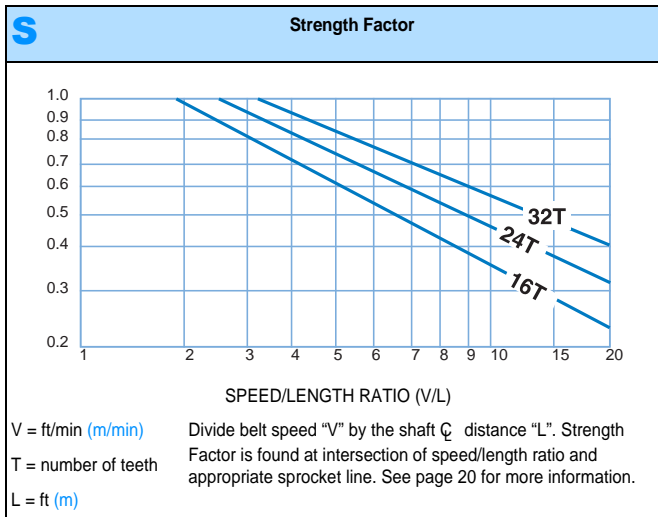

Molded Sprocket ^a										
No. of Teeth (Chordal Action)	Nom. Pitch Dia. in	Nom. Pitch Dia. mm	Nom. Outer Dia. in	Nom. Outer Dia. mm	Nom. Hub Width in	Nom. Hub Width mm	Available Bore Sizes			
							U.S. Sizes		Metric Sizes	
							Round in ^b	Square in	Round mm ^b	Square mm
16 (1.92%)	3.1 ^c	79 ^c	3.2	81	0.5	13		1.5		40
					1.0	25	1.0			
24 (0.86%)	4.6	117	4.8	121	1.0	25		1.5 2.5	30	40 60
								1.5		40
32 (0.48%)	6.1	155	6.5	164	1.0	25		1.5		40

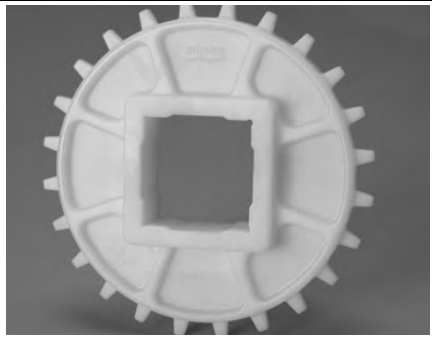

- a. Contact Customer Service for lead times.
- b. Imperial key sizes on round bore sprockets conform to ANSI standard B17.1-1967 (R1989) and metric key sizes conform to DIN standard 6885.
- c. When using 3.1 in (79 mm) pitch diameter sprocket, the Belt Strength for belts rated over 1200 lb/ft (1786 kg/m) will be de-rated to 1200 lb/ft (1786 kg/m) and all other belts will maintain their published rating.

Acetal Split Sprocket ^a										
No. of Teeth (Chordal Action)	Nom. Pitch Dia. in	Nom. Pitch Dia. mm	Nom. Outer Dia. in	Nom. Outer Dia. mm	Nom. Hub Width in	Nom. Hub Width mm	Available Bore Sizes			
							U.S. Sizes		Metric Sizes	
							Round in ^b	Square in	Round mm ^b	Square mm
24 (0.86%)	4.6	117	4.8	121	1.5	38	1.25			
32 (0.48%)	6.1	155	6.5	164	1.5	38			30 40	



- a. Contact Customer Service for lead times.
- b. Imperial key sizes on round bore sprockets conform to ANSI standard B17.1-1967 (R1989) and metric key sizes conform to DIN standard 6885.

HR Nylon Sprocket ^{ab}										
No. of Teeth (Chordal Action)	Nom. Pitch Dia. in	Nom. Pitch Dia. mm	Nom. Outer Dia. in	Nom. Outer Dia. mm	Nom. Hub Width in	Nom. Hub Width mm	Available Bore Sizes			
							U.S. Sizes		Metric Sizes	
							Round in	Square in	Round mm	Square mm
16 (1.92%)	3.1	79	3.2	81	1.0	25	1.9 ^c			



- a. Contact Customer Service for lead times.
- b. Cannot be used with S1000 High Density Insert Roller
- c. 1/4" keyway

Glass-Filled Nylon Split Sprocket^a

No. of Teeth (Chordal Action)	Nom. Pitch Dia. in	Nom. Pitch Dia. mm	Nom. Outer Dia in	Nom. Outer Dia. mm	Nom. Hub Width in	Nom. Hub Width mm	Available Bore Sizes			
							U.S. Sizes		Metric Sizes	
							Round in	Square in	Round mm	Square mm
24 (0.86%)	4.6	117	4.8	121	1.5	38	1 1.25 1.5	1.5		40
32 (0.48%)	6.1	155	6.5	164	1.5	38	1 1.25 1.5	1.5	30 40	40



a. Contact Customer Service for lead times.

Polypropylene Composite Split Sprocket^a

No. of Teeth (Chordal Action)	Nom. Pitch Dia in	Nom. Pitch Dia. mm	Nom. Outer Dia in	Nom. Outer Dia. mm	Nom. Hub Width in	Nom. Hub Width mm	Available Bore Sizes			
							U.S. Sizes		Metric Sizes	
							Round in	Square in	Round mm	Square mm
24 (0.86%)	4.6	117	4.8	121	1.5	38		1.5		40
32 (0.48%)	6.1	155	6.5	164	1.5	38		1.5		40

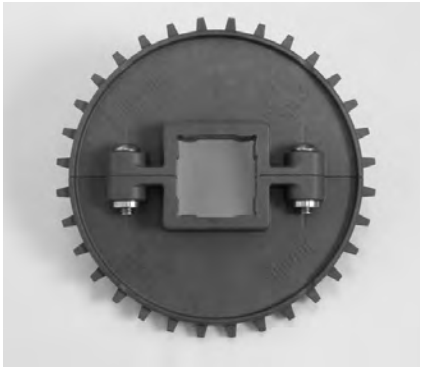

a. Contact Customer Service for lead times.

Conveyor Frame Dimensions

Regardless of type or configuration, all conveyors using Intralox belts have some basic dimensional requirements. Specifically, dimensions "A", "B", "C" and "E" listed below should be implemented in any design.

For general applications and applications where end transfer of tip-sensitive product is not critical, use the "A" dimension at the bottom of the range.

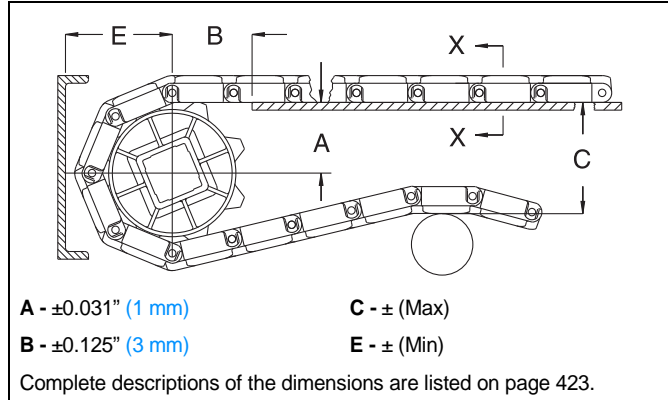

Sprocket Description		A		B		C		E		
Pitch Diameter		No. Teeth	Range (Bottom to Top)		in	mm	in	mm	in	mm
in	mm		in	mm						
SERIES 1000 FLAT TOP, MOLD-TO-WIDTH FLAT TOP, FLAT TOP 85 MM										
3.1	79	16	1.34-1.37	34-35	1.59	40	3.08	78	1.77	45
4.6	117	24	2.11-2.13	54	1.99	50	4.60	117	2.53	64
6.1	155	32	2.88-2.89	73	2.43	62	6.12	155	3.29	84
SERIES 1000 INSERT ROLLER, HIGH DENSITY INSERT ROLLER										
3.1	79	16	1.33	34	1.60	41	3.13	80	1.84	47
4.6	117	24	2.10	53	2.02	51	4.65	118	2.60	66
6.1	155	32	2.87	73	2.46	62	6.18	157	3.36	85
SERIES 1000 FLAT FRICTION TOP, FLAT FRICTION TOP 85 MM										
3.1	79	16	1.35	34	1.59	40	3.17	81	1.86	47
4.6	117	24	2.12	54	2.01	51	4.70	119	2.62	67
6.1	155	32	2.88	73	2.44	62	6.22	158	3.39	86

Dead Plate Gap

Where there is a transfer point from a belt without finger transfer plates to a dead plate, there should be a gap between the surfaces to allow for the chordal action of the belt. As the belt engages its sprockets, chordal action causes the modules to move past a *fixed* point (the tip of the dead plate) with *varying* clearances. The table below shows the minimum amount of gap which occurs at the “low point” of the modules if the tip of the dead plate just comes in contact with the “high point” as the modules pass.

In some installations it may be desirable to keep the tip of the dead plate in contact with the belt, rather than allow a gap to occur. This can be done by hinging the mounting bracket for the dead plate. This allows the dead plate to move as the modules pass, but results in a small oscillating motion which may present tippage problems for sensitive containers or products.

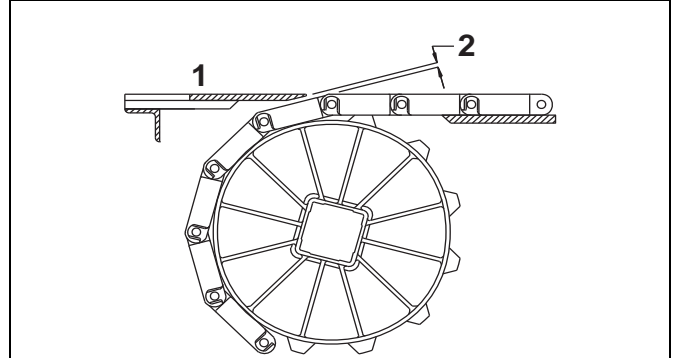

1 - Top surface of dead plate 2 - Dead plate gap

Note: The top surface of the dead plate is typically 0.031 in (0.8 mm) above the belt surface for product transfer onto the belt, and 0.031 in (0.8 mm) below the belt surface for product transfer off the belt.

Sprocket Description		Gap		
Pitch Diameter		No. Teeth	in	mm
in	mm			
3.1	79	16	0.029	0.7
4.6	117	24	0.020	0.5
6.1	155	32	0.015	0.4

Flush Grid		
	in	mm
Pitch	0.60	15.2
Minimum Width	See Product Notes	
Width Increments		
Min. Opening Size (approx.)	0.17 × 0.10	4.3 × 2.5
Max. Opening Size (approx.)	0.31 × 0.10	7.9 × 2.5
Open Area	28%	
Hinge Style	Open	
Drive Method	Hinge-driven	
Product Notes		
<ul style="list-style-type: none"> • Contact Intralox for precise belt measurements and stock status before designing equipment or ordering a belt. • Lightweight with smooth surface grid. • Uses headless rods. • Mini-pitch reduces chordal action and transfer dead plate gap. • Custom-built in widths that vary by material. Acetal and polypropylene are built in widths from 3 in (76 mm) and up, in 0.5 in (12.7 mm) increments. FR-TPES is built in widths from 5 in (127 mm) and up, in 1.0 in (25.4 mm) increments. All other materials are built in widths 3 in (76 mm) and up, in 1.0 in (25.4 mm) increments. • Can be used over 0.875 in (22.2 mm) diameter nosebar for tight transfers. • For information regarding sprocket placement, refer to the Center Sprocket Offset chart on page 410. 		
Additional Information		
<ul style="list-style-type: none"> • See “Belt Selection Process” (page 5) • See “Standard Belt Materials” (page 9) • See “Special Application Belt Materials” (page 9) • See “Friction Factors” (page 13) 		

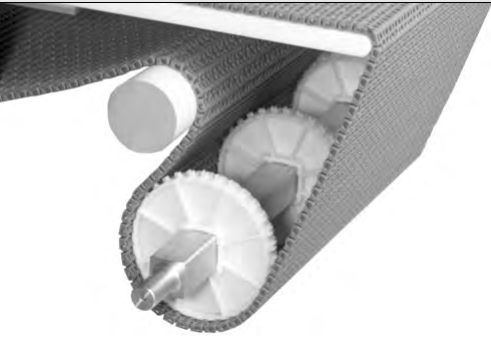
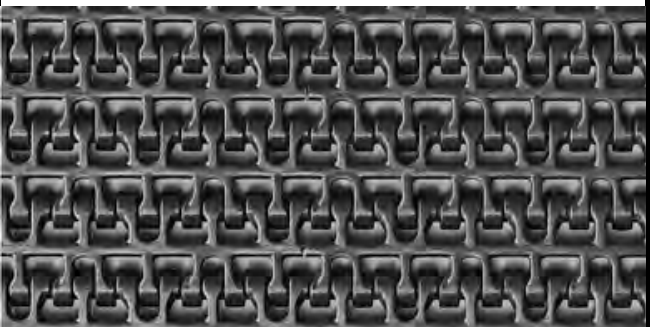
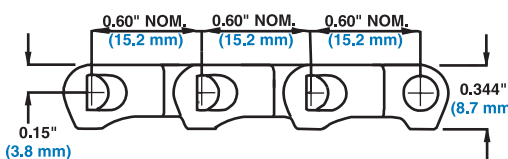



Belt Data											
Belt Material	Standard Rod Material Ø 0.18 in (4.6 mm)	BS		Belt Strength		Temperature Range (continuous)		W		Belt Weight	
		lb/ft	kg/m	°F	°C	lb/ft ²	kg/m ²				
Polypropylene	Polypropylene	700	1040	34 to 220	1 to 104	0.81	3.95				
Polyethylene	Polyethylene	450	670	-50 to 150	-46 to 66	0.87	4.25				
Acetal	Polypropylene	1300	1940	34 to 200	1 to 93	1.19	5.80				
HSEC Acetal	Polypropylene	800	1190	34 to 200	1 to 93	1.19	5.80				
FR-TPES	Polypropylene	750	1120	40 to 150	4 to 66	1.30	6.34				
HHR Nylon	HHR Nylon	1100	1640	-50 to 310	-46 to 154	1.14	5.57				
HR Nylon ^a	Nylon	1100	1640	-50 to 240	-46 to 116	1.07	5.22				
UV Resistant Polypropylene	UV Resistant Polypropylene	700	1040	34 to 220	1 to 104	0.81	3.98				
Detectable Polypropylene A22	Polypropylene	450	670	34 to 150	1 to 66	1.04	5.08				
Acetal ^b	Polyethylene	1200	1790	-50 to 70	-46 to 21	1.19	5.80				
UVFR	UVFR	700	1042	-34 to 200	1 to 93	1.57	7.67				

a. This product may not be used for food contact articles that will come in contact with food containing alcohol.
 b. Polyethylene rods can be used in cold applications when impacts or sudden starts/stops occur. Please note lower rating.

Flat Top

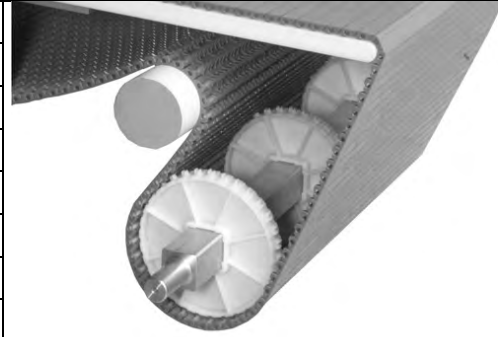
	in	mm
Pitch	0.60	15.2
Minimum Width	3	76
Width Increments	1.00	25.4
Opening Size (approximate)	-	-
Open Area	0%	
Hinge Style	Open	
Drive Method	Hinge-driven	



Product Notes

- **Contact Intralox for precise belt measurements and stock status before designing equipment or ordering a belt.**
- Lightweight with smooth, closed surface grid.
- Uses headless rods.
- Mini-pitch reduces chordal action and transfer dead plate gap.
- Can be used over 0.875 in (22.2 mm) diameter nosebar for tight transfers.
- For information regarding sprocket placement, refer to the Center Sprocket Offset chart on page 410.

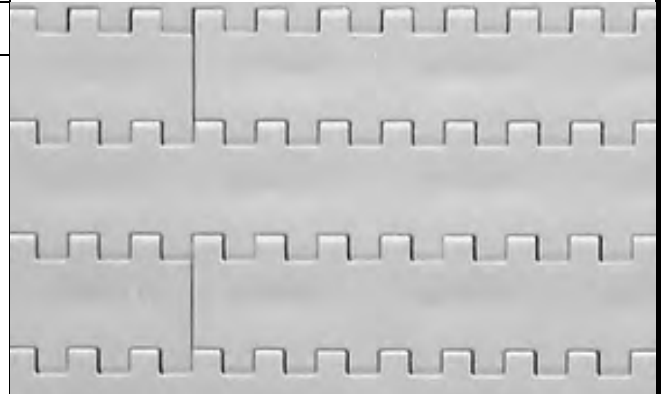

Additional Information

- See "Belt Selection Process" (page 5)
- See "Standard Belt Materials" (page 9)
- See "Special Application Belt Materials" (page 9)
- See "Friction Factors" (page 13)

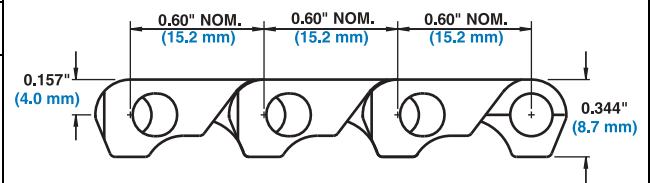

Belt Data

Belt Material	Standard Rod Material Ø 0.18 in (4.6 mm)	BS Belt Strength		Temperature Range (continuous)		W Belt Weight	
		lb/ft	kg/m	°F	°C	lb/ft ²	kg/m ²
Polypropylene	Polypropylene	500 ^a	744 ^a	34 to 220	1 to 104	0.90	4.40
Polyethylene	Polyethylene	300 ^a	450 ^a	-50 to 150	-46 to 66	0.96	4.69
HR Nylon	Nylon	500	744	-50 to 240	-46 to 116	1.15	5.61
Acetal	Polypropylene	1000	1490	34 to 200	1 to 93	1.30	6.35
Acetal ^b	Polyethylene	900	1340	-50 to 70	-46 to 21	1.30	6.35
X-Ray Detectable Acetal	X-Ray Detectable Acetal	800	1191	-50 to 200	-46 to 93	1.6	7.81
Detectable Polypropylene A22	Polypropylene	300	446	34 to 150	1 to 66	1.09	5.32

- a. When using steel split sprockets, the belt strength for polypropylene is 400 lb/ft (595 kg/m); polyethylene is 240 lb/ft (360 kg/m)
- b. Polyethylene rods can be used in cold applications when impacts or sudden starts/stops occur. Please note lower rating.

Perforated Flat Top		
	in	mm
Pitch	0.60	15.2
Minimum Width	3	76
Width Increments	1.00	25.4
Opening Size (approximate)	-	-
Open Area	See Product Notes	
Hinge Style	Open	
Drive Method	Hinge-driven	

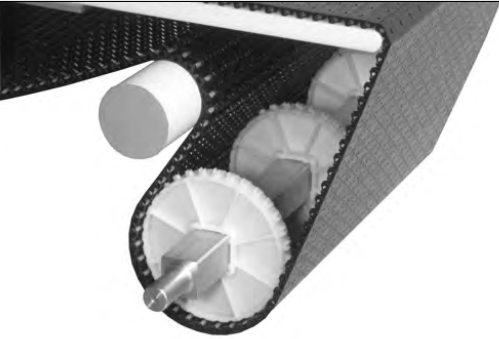

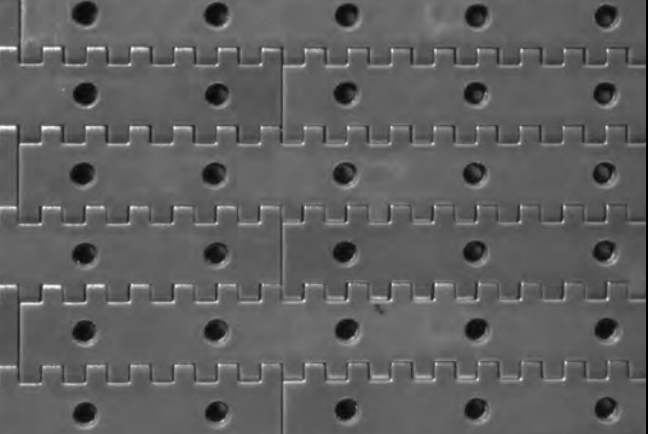
Product Notes	
<ul style="list-style-type: none"> Contact Intralox for precise belt measurements and stock status before designing equipment or ordering a belt. Uses headless rods. For use on vacuum applications requiring tight, end-to-end transfers. Underside design and small pitch allow the belt to run smoothly around nosebars. Available with 5/32 in (4 mm) round perforations on a nominal 1 in (25.4 mm) x 0.6 in (15.2 mm) perforation pattern. 5.3% open area includes 2.1% open area at the hinge. Can be used over 0.875 in (22.2 mm) diameter nosebar for tight transfers. For information regarding sprocket placement, refer to the Center Sprocket Offset chart on page 410. 	

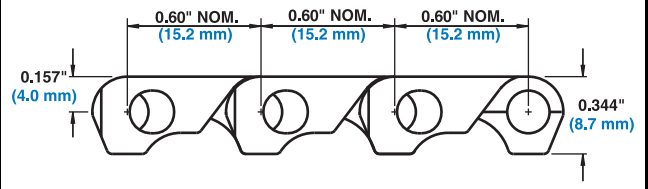
Additional Information	
<ul style="list-style-type: none"> See "Belt Selection Process" (page 5) See "Standard Belt Materials" (page 9) See "Special Application Belt Materials" (page 9) See "Friction Factors" (page 13) 	

Belt Data							
Belt Material	Standard Rod Material Ø 0.18 in (4.6 mm)	BS Belt Strength		Temperature Range (continuous)		W Belt Weight	
		lb/ft	kg/m	°F	°C	lb/ft ²	kg/m ²
Acetal	Polypropylene	1000	1490	34 to 200	1 to 93	1.30	6.35
Acetal ^a	Polyethylene	900	1340	-50 to 70	-46 to 21	1.30	6.35

a. Polyethylene rods can be used in cold applications when impacts or sudden starts/stops occur. Please note lower rating.

Flush Grid Friction Top

	in	mm
Pitch	0.60	15.2
Minimum Width	3	76
Width Increments	0.5	12.7
Opening Size (approximate)	0.17 x 0.10	4.3 x 2.5
Open Area	28%	
Hinge Style	Open	
Drive Method	Hinge-driven	

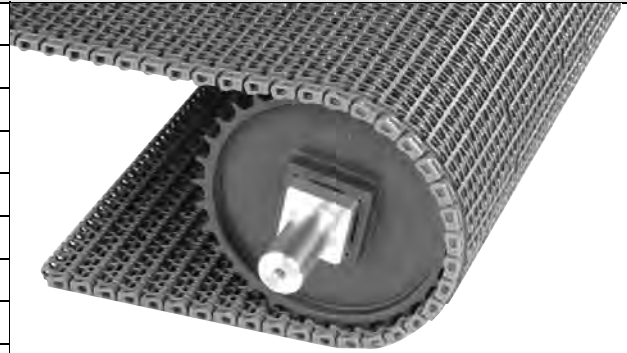

Product Notes

- **Contact Intralox for precise belt measurements and stock status before designing equipment or ordering a belt.**
- Available in grey PP with grey rubber, blue PP with blue rubber, grey PP with black rubber, and white PP with white rubber.
- Uses headless rods.
- Can be used over 0.875 in (22.2 mm) diameter nosebar for tight transfers.
- For information regarding sprocket placement, refer to the Center Sprocket Offset chart on page 410.
- Belts have a 0.34 in (8.6 mm) molded indent.
- If a center-drive setup is used, it may be necessary to place collars to laterally retain the belt at the backbend roller before the drive. Abrasion resistant rods are recommended.
- Temperature, environmental conditions, and product characteristics affect the effective maximum degree of incline. Take these items into consideration when designing conveyor systems utilizing these belts.

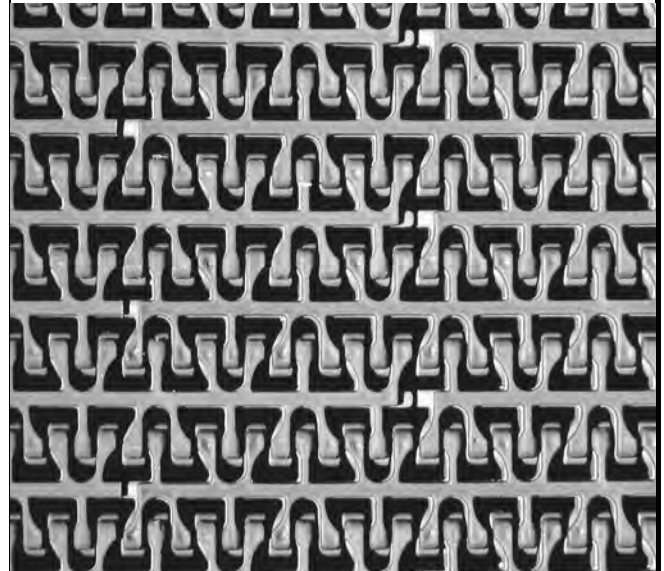

Additional Information

- See "Belt Selection Process" (page 5)
- See "Standard Belt Materials" (page 9)
- See "Special Application Belt Materials" (page 9)
- See "Friction Factors" (page 13)

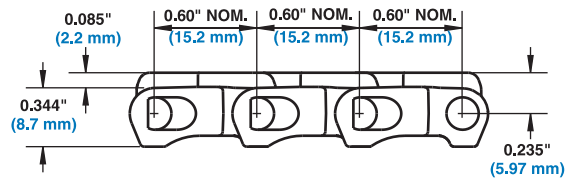

Belt Data

Base Belt Material	Base/Friction Color	Standard Rod Material Ø 0.18 in (4.6 mm)	BS Belt Strength		Temperature Range (continuous)		W Belt Weight		Friction Top Hardness	Agency Acceptability	
			lb/ft	kg/m	°F	°C	lb/ft²	kg/m²		FDA (USA)	EU MC ^b
Polypropylene	Grey/Grey	Polypropylene	700	1040	34 to 150	1 to 66	1.18	5.76	64 Shore A		
Polypropylene	Grey/Black	Polypropylene	700	1040	34 to 150	1 to 66	1.18	5.76	55 Shore A	a	
Polypropylene	White/White	Polypropylene	700	1040	34 to 150	1 to 66	1.18	5.76	55 Shore A	a	c
Polypropylene	High Performance FT Blue/Blue	Polypropylene	700	1040	34 to 212	1 to 100	1.18	5.76	59 Shore A	a	c
Polypropylene	Blue/Blue	Polypropylene	700	1040	34 to 150	1 to 66	1.18	5.76		a	c

• - Fully compliant

a - FDA Compliant with Restriction: Do not use in direct contact with fatty foods.

b - European Migration Certificate providing approval for food contact according to EU Regulation 10/2011.

c - EU compliant with Restriction: Do not use in direct contact with fatty foods.

Flush Grid Friction Top, No Indent

	in	mm
Pitch	0.60	15.2
Minimum Width	3	76
Width Increments	0.5	12.7
Opening Size (approximate)	0.17 × 0.10	4.3 × 2.5
Open Area	28%	
Hinge Style	Open	
Drive Method	Hinge-driven	



Product Notes

- **Contact Intralox for precise belt measurements and stock status before designing equipment or ordering a belt.**
- Available in blue PP with blue rubber.
- Uses headless rods.
- Can be used over 0.875 in (22.2 mm) diameter nosebar for tight transfers.
- For information regarding sprocket placement, refer to the Center Sprocket Offset chart on Page 1.
- If a center-drive setup is used, it may be necessary to place collars to laterally retain the belt at the backbend roller before the drive. Abrasion resistant rods are recommended.
- Temperature, environmental conditions, and product characteristics affect the effective maximum degree of incline. Take these items into consideration when designing conveyor systems utilizing these belts.

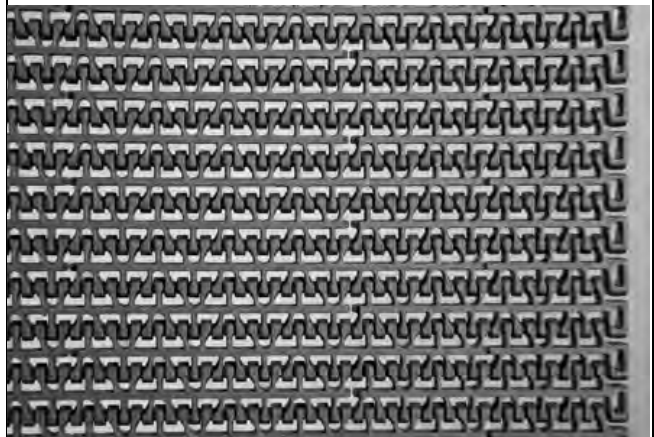

Additional Information

- See "Belt Selection Process" (page 5)
- See "Standard Belt Materials" (page 9)
- See "Special Application Belt Materials" (page 9)
- See "Friction Factors" (page 13)

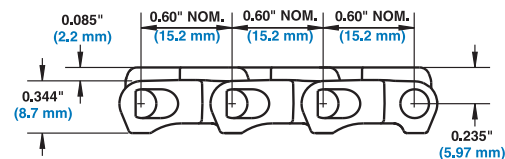

Belt Data

Base Belt Material	Base/Friction Color	Standard Rod Material Ø 0.18 in (4.6 mm)	BS Belt Strength		Temperature Range (continuous)		W Belt Weight		Friction Top Hardness	Agency Acceptability	
			lb/ft	kg/m	°F	°C	lb/ft²	kg/m²		FDA (USA)	EU MC ^b
Polypropylene	Blue/Blue	Polypropylene	700	1040	34 to 150	1 to 66	1.07	5.22	55 Shore A	a	c
Polypropylene	High Performance FT Blue/Blue	Polypropylene	700	1040	34 to 212	1 to 100	1.18	5.76	59 Shore A	a	c

• - Fully compliant

a - FDA Compliant with Restriction: Do not use in direct contact with fatty foods.

b - European Migration Certificate providing approval for food contact according to EU Regulation 10/2011.

c - EU compliant with Restriction: Do not use in direct contact with fatty foods.

ONEPIECE™ Live Transfer Flush Grid

	in	mm
Pitch	0.60	15.2
Minimum Width	6	152
Width Increments	1.00	25.4
Min. Opening Size (approx.)	0.17 × 0.10	4.3 × 2.5
Max. Opening Size (approx.)	0.31 × 0.10	7.9 × 2.5
Open Area	28%	
Hinge Style	Open	
Drive Method	Hinge-driven	



Product Notes

- Contact Intralox for precise belt measurements and stock status before designing equipment or ordering a belt.
- Lightweight with smooth surface grid.
- Mini-pitch reduces chordal action, resulting in a smoother product transfer.
- Uses headed rods.
- Transfer edge is an integral part of this belt.
- Designed for smooth, self-clearing, right angle transfers onto takeaway belts.
- Molded tracking tabs fit into standard 1-3/4 in (44.5 mm) wearstrip tracks ensuring proper belt alignment.
- Built with nylon rods for superior wear resistance.
- Recommended for use with EZ tracking sprockets.
- You may need to include a fixed frame support member beneath the ONEPIECE™ Live Transfer belt prior to the actual transfer. This ensures that the ONEPIECE™ Live Transfer belt does not snag when it intersects with the takeaway belt. See "Fig. 3-31 PARABOLIC GUIDE RAIL CONTOURS WITH 6.0 in. (152 mm) ONEPIECE™ LIVE TRANSFER BELT" (page 442).
- Also available in 6 in (152 mm) Mold to Width.
- Use sprockets with a pitch diameter of 3.5 in (89 mm) or larger.
- For custom belt widths, contact Customer Service.

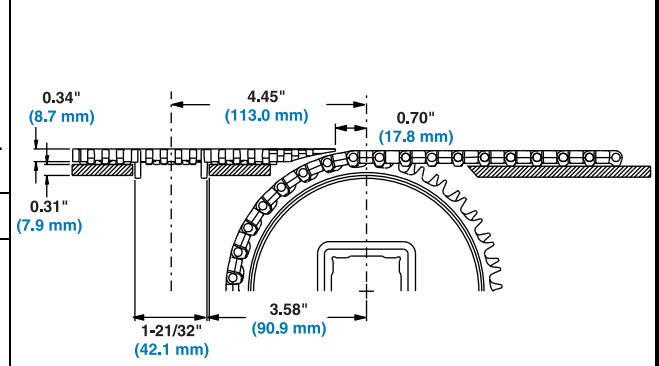
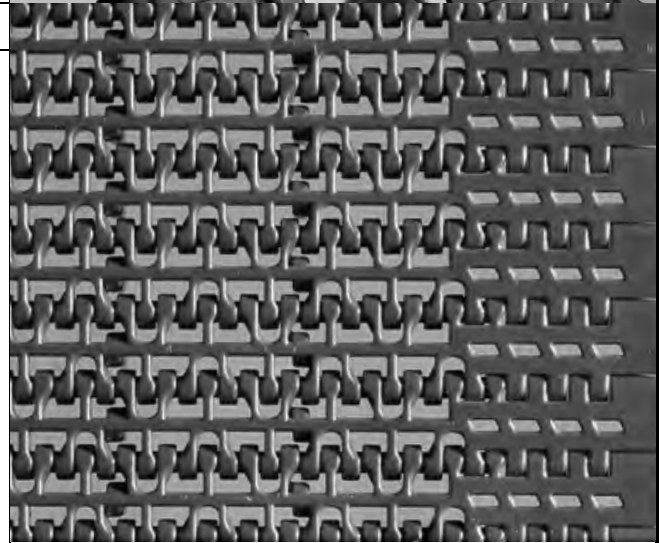

Additional Information

- See "Belt Selection Process" (page 5)
- See "Standard Belt Materials" (page 9)
- See "Special Application Belt Materials" (page 9)
- See "Friction Factors" (page 13)

Belt Data

Belt Material	Standard Rod Material Ø 0.18 in (4.6 mm)	BS		Temperature Range (continuous)		W	
		Belt Strength		°F	°C	Belt Weight	
		lb/ft	kg/m			lb/ft²	kg/m²
Acetal	Nylon	1300	1940	34 to 200	1 to 93	1.19	5.80
FR-TPES	Nylon	750	1120	40 to 150	4 to 66	1.30	6.34
HHR Nylon	HHR Nylon	1100	1640	-50 to 310	-46 to 154	1.20	5.80

Flush Grid Nub Top™		
	in	mm
Pitch	0.60	15.2
Minimum Width	3	76
Width Increments	1.00	25.4
Opening Size (approx.)	0.18 × 0.09	4.4 × 2.3
Open Area	15%	
Product Contact Area	26%	
Hinge Style	Open	
Drive Method	Hinge-driven	

Product Notes

- Contact Intralox for precise belt measurements and stock status before designing equipment or ordering a belt.
- Standard Nub indent is 1.0 inch (25.4 mm).
- Uses headless rods.
- Nub pattern reduces contact between belt surface and product.
- Manufactured in acetal, polypropylene, and polyethylene (for frozen products).
- Recommended for products large enough to span the distance between the nubs.
- Flush Grid Nub Top flights are available.

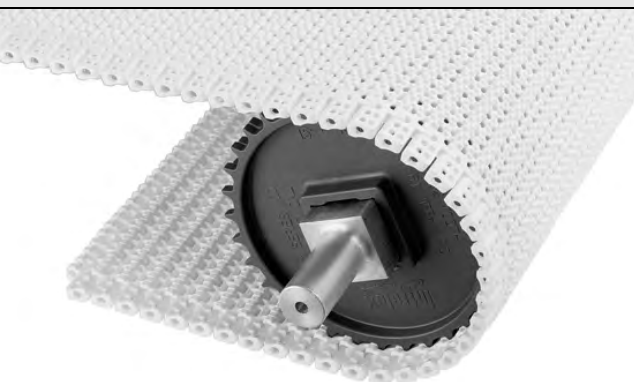
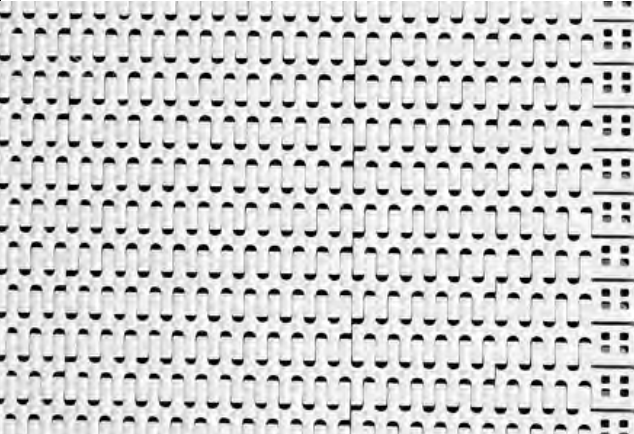
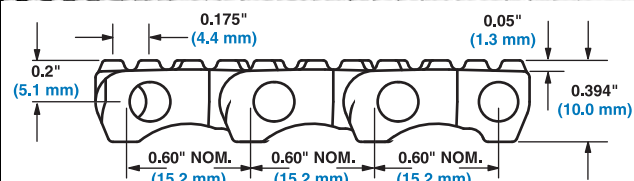
Additional Information	
<ul style="list-style-type: none"> See "Belt Selection Process" (page 5) See "Standard Belt Materials" (page 9) See "Special Application Belt Materials" (page 9) See "Friction Factors" (page 13) 	

Belt Data							
Belt Material	Standard Rod Material Ø 0.18 in (4.6 mm)	BS Belt Strength ^a		Temperature Range (continuous)		W Belt Weight	
		lb/ft	kg/m	°F	°C	lb/ft ²	kg/m ²
Polypropylene	Polypropylene	700	1040	34 to 220	1 to 104	0.93	4.55
Acetal	Polypropylene	1300	1940	34 to 220	7 to 93	1.36	6.65
Polyethylene	Polyethylene	450	670	-50 to 150	-46 to 66	1.00	4.90
Acetal	Polyethylene	1200	1790	-50 to 70	-46 to 21	1.36	6.65

a. When using polyurethane sprockets, the Belt Strength for polypropylene, acetal, and nylon is 750 lbs/ft (1120 kg/m), and the temperature range for the sprocket is 0 °F (-18 °C) to 120 °F (49 °C). Contact Customer Service for availability of polyurethane sprockets.

Embedded Diamond Top

	in	mm
Pitch	0.60	15.2
Minimum Width	3	76
Width Increments	1.00	25.4
Opening Size (approx.)	-	-
Open Area	0%	
Hinge Style	Open	
Drive Method	Hinge-driven	

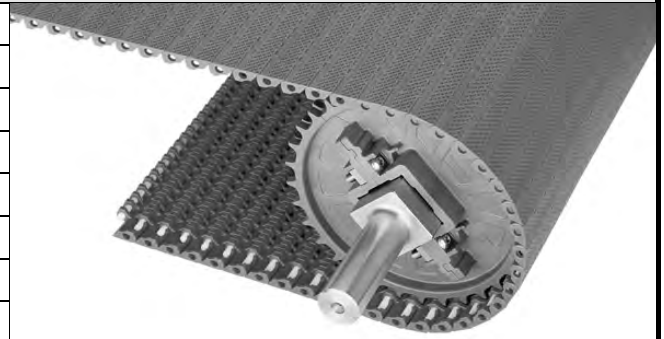

Product Notes

- **Contact Intralox for precise belt measurements and stock status before designing equipment or ordering a belt.**
- Lightweight with smooth, closed surface grid.
- Uses headless rods.
- Mini-pitch reduces chordal action and transfer dead plate gap.
- Can be used over 0.875 in (22.2 mm) diameter nosebar for tight transfers.
- For information regarding sprocket placement, refer to the Center Sprocket Offset chart on page 410.

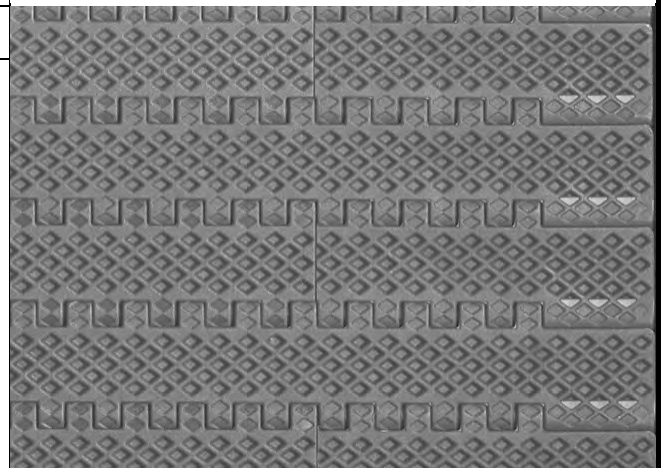

Additional Information

- See "Belt Selection Process" (page 5)
- See "Standard Belt Materials" (page 9)
- See "Special Application Belt Materials" (page 9)
- See "Friction Factors" (page 13)

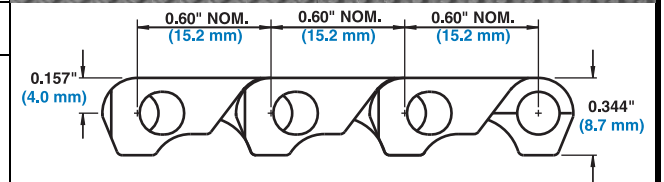

Belt Data

Belt Material	Standard Rod Material Ø 0.18 in (4.6 mm)	BS Belt Strength ^a		Temperature Range (continuous)		W Belt Weight	
		lb/ft	kg/m	°F	°C	lb/ft ²	kg/m ²
Polyethylene	Polyethylene	300	450	-50 to 150	-46 to 66	0.96	4.69

a. When using steel sprockets, the belt strength for polyethylene is 240 lb/ft (360 kg/m).

Cone Top™		
	in	mm
Pitch	0.60	15.2
Minimum Width	9	229
Width Increments	1.00	25.4
Opening Size (approx.)	-	-
Open Area	0%	
Hinge Style	Open	
Drive Method	Hinge-driven	
Product Notes		
<ul style="list-style-type: none"> • Contact Intralox for precise belt measurements and stock status before designing equipment or ordering a belt. • Uses headless rods. • Mini-pitch reduces chordal action and transfer dead plate gap. • Can be used over 0.875 in (22.2 mm) diameter nosebar for tight transfers. • For information regarding sprocket placement, refer to the Center Sprocket Offset chart on page 410. • Minimum nominal alternating edge indents of 2.in (51 mm) and 3 in (76 mm). 		
Additional Information		
<ul style="list-style-type: none"> • See "Belt Selection Process" (page 5) • See "Standard Belt Materials" (page 9) • See "Special Application Belt Materials" (page 9) • See "Friction Factors" (page 13) 		

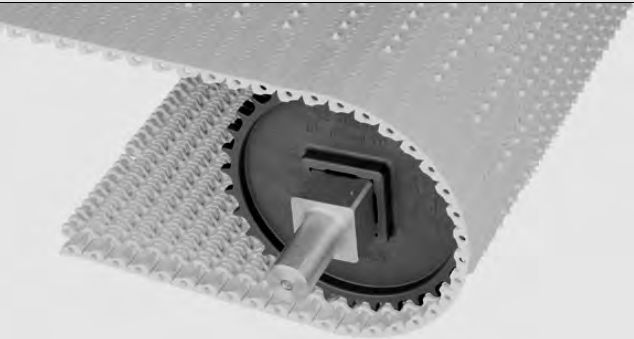
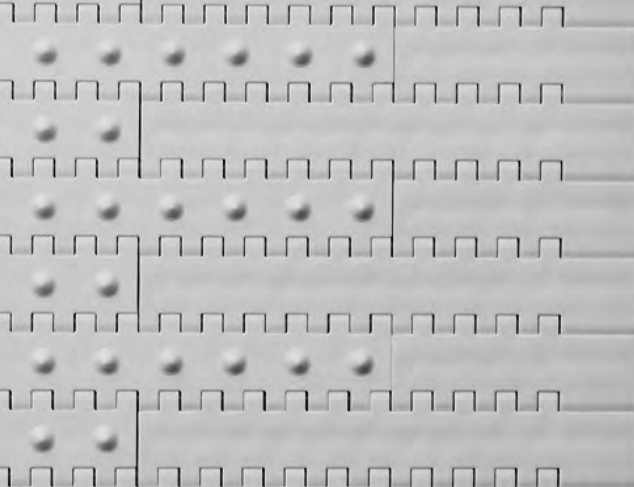
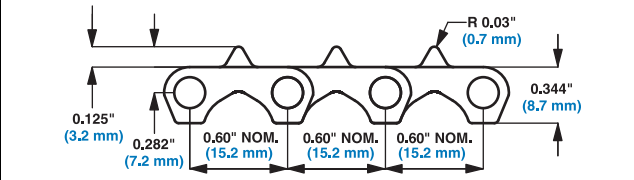
Belt Data									
Belt Material	Standard Rod Material Ø 0.18 in (4.6 mm)	BS	Belt Strength		Temperature Range (continuous)		W	Belt Weight	
			lb/ft	kg/m	°F	°C		lb/ft ²	kg/m ²
Acetal	Polypropylene	1000	1490	34 to 200	1 to 93	1.31	6.40		
HR Nylon	Nylon	500	744	-50 to 240	-46 to 116	1.18	5.76		

Flush Grid Mold to Width, 38 and 46 mm Wide

	in	mm
Pitch	0.60	15.2
Molded Widths	1.5 & 1.8	38 & 46
Min. Opening Size (approx.)	0.17 × 0.10	4.3 × 2.5
Max. Opening Size (approx.)	0.31 × 0.10	7.9 × 2.5
Open Area	26%	
Hinge Style	Open	
Drive Method	Hinge-driven	



Product Notes

- **Contact Intralox for precise belt measurements and stock status before designing equipment or ordering a belt.**
- Boxed in 10 ft (3.05 m) increments.
- Flush edges with snap-in rod retention.
- Uses headed rods.
- Tracking tabs provide lateral tracking.
- All chains come with nylon rodlets standard, providing longer service life.
- Lightweight with smooth surface grid.
- Can be used over 0.875 in (22.2 mm) diameter nosebar for tight transfers.
- One (1) sprocket maximum per shaft for both widths.
- EZ Track™ sprockets only.
- The 38 mm belt has a 1.2 in (30.6 mm) spacing between tabs. The 46 mm belt has a 1.54 in (39.1 mm) spacing.

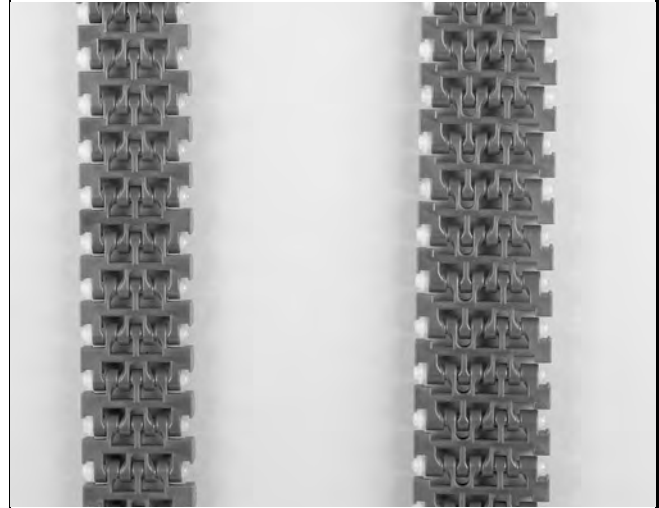

Additional Information

- See "Belt Selection Process" (page 5)
- See "Standard Belt Materials" (page 9)
- See "Special Application Belt Materials" (page 9)
- See "Friction Factors" (page 13)

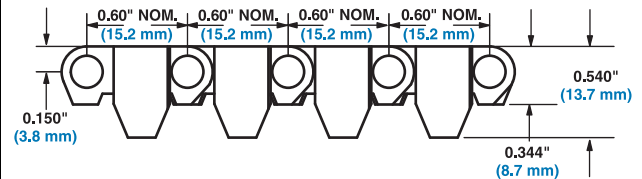

Belt Data

Belt Material	Standard Rod Material Ø 0.18 in (4.6 mm)	BS Belt Strength ^a		Temperature Range (continuous)		W Belt Weight	
		lb	kg	°F	°C	lb/ft	kg/m
Acetal (38 mm)	Nylon	130	59	-50 to 200	-46 to 93	0.185	0.275
Acetal (46 mm)	Nylon	150	68	-50 to 200	-46 to 93	0.216	0.321

a. When using steel sprockets, the belt strength for polyethylene is 240 lb/ft (360 kg/m).

Sprocket and Support Quantity Reference ^a				
Belt Width Range ^b		Minimum Number of Sprockets Per Shaft ^c	Wearstrips	
in.	mm		Carryway	Returnway ^d
3	76	1	2	2
4	102	1	2	2
6	152	2	2	2
7	178	2	3	2
8	203	2	3	2
10	254	3	3	2
12	305	3	3	2
14	356	5	4	3
15	381	5	4	3
16	406	5	4	3
18	457	5	4	3
20	508	5	5	3
24	610	7	5	3
30	762	9	6	4
32	813	9	7	4
36	914	9	7	4
42	1067	11	8	5
48	1219	13	9	5
54	1372	15	10	6
60	1524	15	11	6
72	1829	19	13	7
84	2134	21	15	8
96	2438	25	17	9
120	3048	31	21	11
144	3658	37	25	13
For Other Widths, Use Odd Number of Sprockets ^e at Maximum 4 in. (102 mm) \varnothing Spacing			Maximum 6 in. (152 mm) \varnothing Spacing	Maximum 12 in. (305 mm) \varnothing Spacing

- a. Because of the single plate steel design, Intralox recommends using twice as many 8 and 12 tooth sprockets as indicated.
- b. If your belt width exceeds a number listed in the table, please refer to the sprocket and support material minimums for the next larger width range listed. Belts are available in 1.00 in. (25.4 mm) increments beginning with minimum width of 3 in. (76 mm). **If the actual width is critical, consult Customer Service.**
- c. These are the minimum number of sprockets. Additional sprockets may be required for heavily loaded applications.
- d. Caution when using Friction Top. **Contact Intralox Customer Service for friction top applications.**
- e. The center sprocket should be locked down. With only two sprockets, fix the sprocket on the drive journal side only. See Retainer Rings/Center Sprocket Offset chart on page 410 for lock down location.

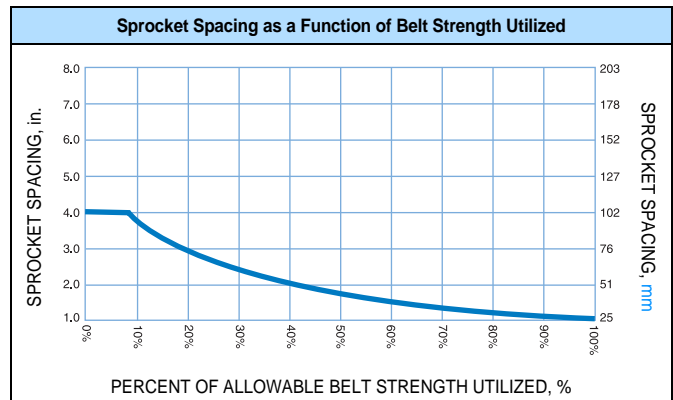
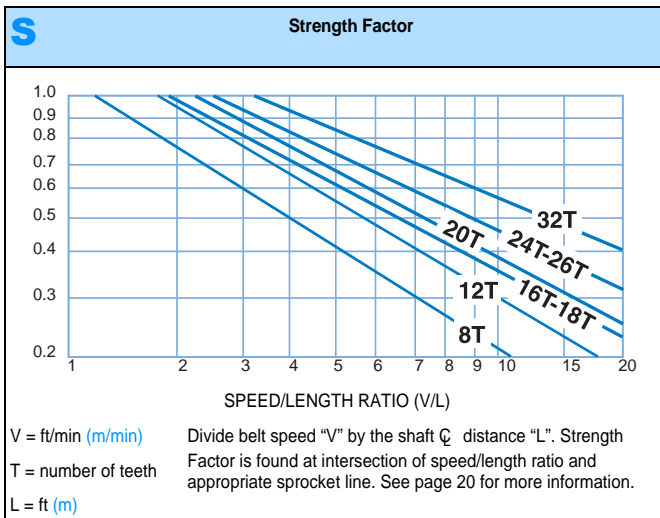

Molded Sprocket^a										
No. of Teeth (Chordal Action)	Nom. Pitch Dia. in	Nom. Pitch Dia. mm	Nom. Outer Dia. in	Nom. Outer Dia. mm	Nom. Hub Width in	Nom. Hub Width mm	Available Bore Sizes			
							U.S. Sizes		Metric Sizes	
							Round in ^b	Square in	Round mm ^b	Square mm
12 (3.41%)	2.3	58	2.3	58	0.75	19	1.0	1.0	25	25
16 (1.92%)	3.1	79	3.1	79	1.0	25	1 to 1-1/4	1.5	25 to 30	40
18 (1.52%)	3.5	89	3.5	89	0.75	19		1.0		25
								1.5		40
20 (1.23%)	3.8	97	3.8	97	1.0	25		1.5		40
24 (0.86%)	4.6	117	4.7	119	1.0	25	1 to 1-1/4	1.5	25 to 30	40
								2.5		60
26 (0.73%)	5.1	130	5.1	130	1.0	25	1 to 1-1/4	1.5	25 to 30	40
32 (0.48%)	6.1	155	6.2	157	1.0	25	1 to 1-1/4	1.5	25 to 30	40
								2.5		60

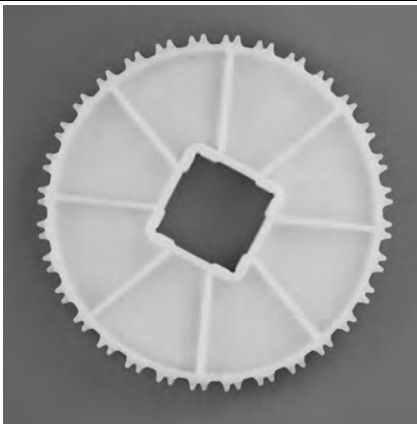

- a. **Contact Customer Service for lead times.**
- b. Round bore molded and split sprockets are frequently furnished with two keyways. Use of two keys is NOT REQUIRED nor recommended. Round bore sprockets do not have set screws for locking the sprockets in place. As with square bore sprockets, only the center-most sprocket needs to be locked down. Imperial key sizes on round bore sprockets conform to ANSI standard B17.1-1967 (R1989) and metric key sizes conform to DIN standard 6885.

Abrasion Resistant Metal Sprocket^a										
No. of Teeth (Chordal Action)	Nom. Pitch Dia. in	Nom. Pitch Dia. mm	Nom. Outer Dia. in	Nom. Outer Dia. mm	Nom. Hub Width in	Nom. Hub Width mm	Available Bore Sizes			
							U.S. Sizes		Metric Sizes	
							Round in ^b	Square in	Round mm ^b	Square mm
8 (7.61%)	1.6	41	1.6	41	0.164	4.2	3/4	5/8	20	
12 (3.41%)	2.3	58	2.3	58	0.164	4.2	1.0	1.0	25	25

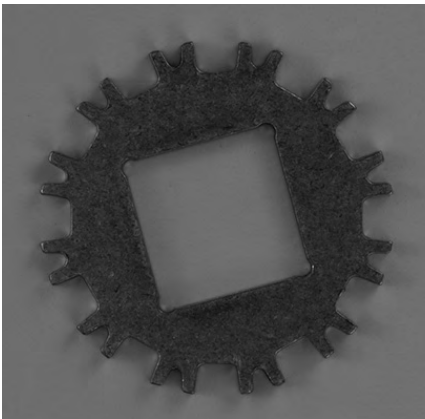

- a. **Contact Customer Service for lead times.**
- b. The stainless steel sprockets have a male key in the round bore sizes. Since the key is part of the sprocket, only the center sprockets should be locked down to track the belt. The male key requires that the shaft keyway run the entire length of the shaft. Imperial key sizes on round bore sprockets conform to ANSI standard B17.1-1967 (R1989) and metric key sizes conform to DIN standard 6885.

Split Metal Sprocket^a										
No. of Teeth (Chordal Action)	Nom. Pitch Dia. in	Nom. Pitch Dia. mm	Nom. Outer Dia. in	Nom. Outer Dia. mm	Nom. Hub Width in	Nom. Hub Width mm	Available Bore Sizes			
							U.S. Sizes		Metric Sizes	
							Round in ^b	Square in	Round mm ^b	Square mm
18 (1.54%)	3.5	89	3.5	89	1.7	43		1.5		40
24 (0.86%)	4.6	117	4.7	119	1.7	43	1 1-3/16 1-1/4	1.5	30	40
26 (0.73%)	5.1	130	5.1	130	1.7	43	1 1-3/16 1-1/4	1.5 2.5		40 60
32 (0.48%)	6.1	155	6.2	157	1.7	43	1 1-3/16 1-1/4 1-1/2	1.5 2.5		40 60

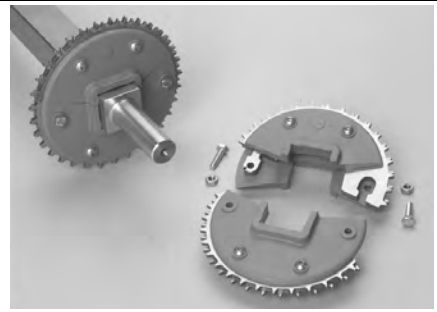

- a. **Contact Customer Service for lead times.**
- b. Imperial key sizes on round bore sprockets conform to ANSI standard B17.1-1967 (R1989) and metric key sizes conform to DIN standard 6885

EZ Track™ Molded Sprocket^a										
No. of Teeth (Chordal Action)	Nom. Pitch Dia. in	Nom. Pitch Dia. mm	Nom. Outer Dia. in	Nom. Outer Dia. mm	Nom. Hub Width in	Nom. Hub Width mm	Available Bore Sizes			
							U.S. Sizes		Metric Sizes	
							Round in	Square in	Round mm	Square mm
16 (1.92%)	3.1	79	3.1	79	1.0	25		1.5		40
18 (1.52%)	3.5	89	3.5	89	1.0	25		1.5		40
24 (0.86%)	4.6	117	4.7	119	1.0	25		1.5 2.5		40 60
32 (0.48%)	6.1	155	6.2	157	1.0	25		1.5 2.5		40 60

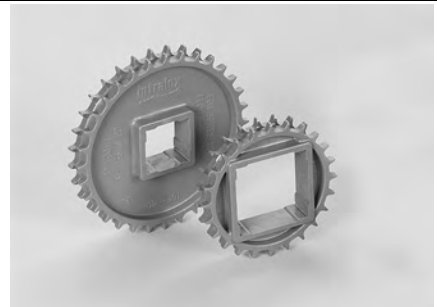

- a. **Contact Customer Service for lead times.**

EZ Track™ Glass Filled Nylon Split Sprocket^a										
No. of Teeth (Chordal Action)	Nom. Pitch Dia. in	Nom. Pitch Dia. mm	Nom. Outer Dia. in	Nom. Outer Dia. mm	Nom. Hub Width in	Nom. Hub Width mm	Available Bore Sizes			
							U.S. Sizes		Metric Sizes	
							Round in	Square in	Round mm	Square mm
24 (0.86%)	4.6	117	4.7	119	1.5	38		1.5		40
32 (0.48%)	6.1	155	6.2	157	1.5	38		1.5 2.5		40 60

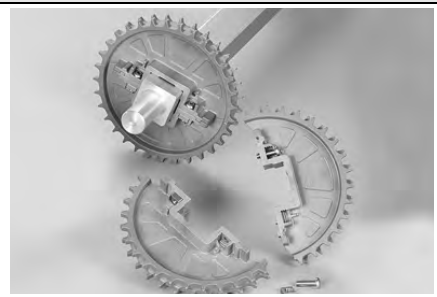

- a. **Contact Customer Service for lead times.**

EZ Track™/EZ Clean™ Sprocket^a

No. of Teeth (Chordal Action)	Nom. Pitch Dia. in	Nom. Pitch Dia. mm	Nom. Outer Dia. in	Nom. Outer Dia. mm	Nom. Hub Width in	Nom. Hub Width mm	Available Bore Sizes			
							U.S. Sizes		Metric Sizes	
							Round in	Square in	Round mm	Square mm
12 (3.41%)	2.3	58	2.3	58	1.0	25	1.0	1.0	25	25
16 (1.92%)	3.1	79	3.1	79	1.0	25	1.0		25	
							1-1/16, 1-1/8, 1-1/4		30	
18 (1.52%)	3.5	89	3.5	89	1.0	25	1.0	1.0		25
20 (1.23%)	3.8	97	3.8	97	1.0	25		1.5		40
24 (0.86%)	4.6	117	4.7	119	1.0	25	1.0		25	
							1-1/16, 1-1/8, 1-3/16, 1-1/4		30	
26 (0.73%)	5.1	130	5.1	130	1.0	25	1.0	1.5	25	40
							1-1/16, 1-1/8, 1-1/4		30	
32 (0.48%)	6.1	155	6.2	157	1.0	25	1.0		25	
							1-1/16, 1-1/8, 1-3/16, 1-1/4 1-1/2		30 40	



a. Contact Customer Service for lead times.

Flat Top Base Flights (Streamline)

Available Flight Height		Available Materials
in	mm	
2	51	Polypropylene, Polyethylene, Acetal

Note: Flights can be cut down to custom heights with a minimum height of 0.25 in (13 mm).

Note: No fasteners required.

Note: Flat Top flight is smooth (Streamline) on both sides.

Note: The Flat Top base streamline flights are used in both Flat Top and Flush Grid belts.

Note: The minimum recommended indent for Flat Top is 2 in (51 mm). The minimum recommended indent for Flush Grid is 1.5 in (38 mm).

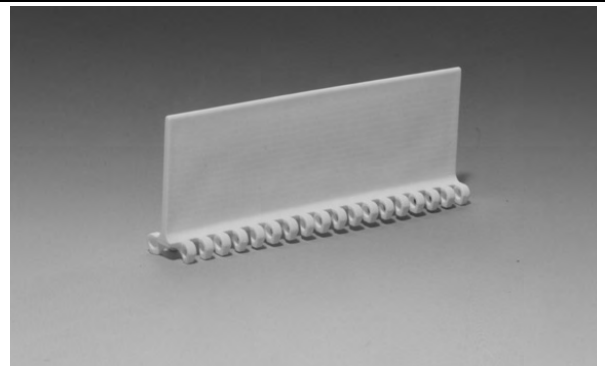

Flush Grid Nub Top Base Flights (No-Cling)

Available Flight Height		Available Materials
in	mm	
2	51	Polypropylene, Polyethylene, Acetal
3	76	Polypropylene, Acetal

Note: Flights can be cut down to custom heights with a minimum height of 0.25 in (13 mm).

Note: Each flight rises out of the center of the module, molded as an integral part. No fasteners required.

Note: The No-Cling vertical ribs are on both sides of the flight.

Note: The minimum recommended indent is 1 in (25 mm).

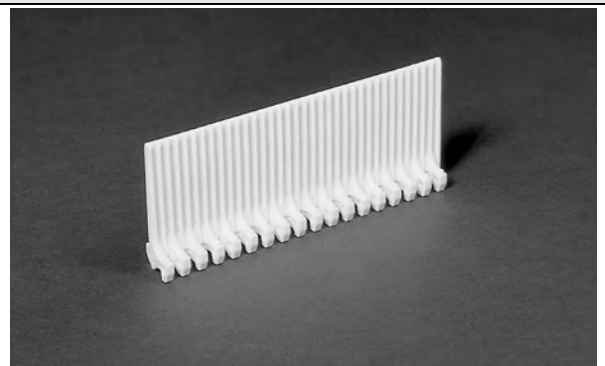

Sideguards			
Available Sizes		Available Materials	
in	mm		
2	51		
Polypropylene, Polyethylene, Acetal			

Note: No fasteners required.

Note: The minimum indent is 1.3 in (33 mm). The standard gap between the sideguards and the edge of a flight is 0.2 in (5 mm).

Note: When going around the 8, 12, 16 and 18 tooth sprockets, the sideguards will fan out, opening a gap at the top of the sideguard which might allow small products to fall out. The sideguards stay completely closed when wrapping around the 24 tooth and larger sprockets.

Note: Standard sideguard orientation is angled inward toward the product (product friendly). If needed, sideguards can be angled outward toward the conveyor.

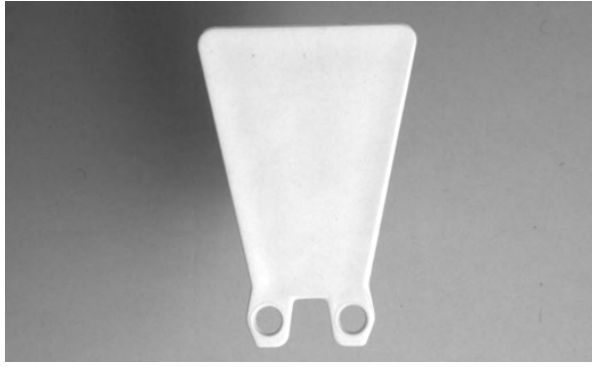

Conveyor Frame Dimensions

Regardless of type or configuration, all conveyors using Intralox belts have some basic dimensional requirements. Specifically, dimensions “A”, “B”, “C” and “E” listed below should be implemented in any design.

For general applications and applications where end transfer of tip-sensitive product is not critical, use the “A” dimension at the bottom of the range.

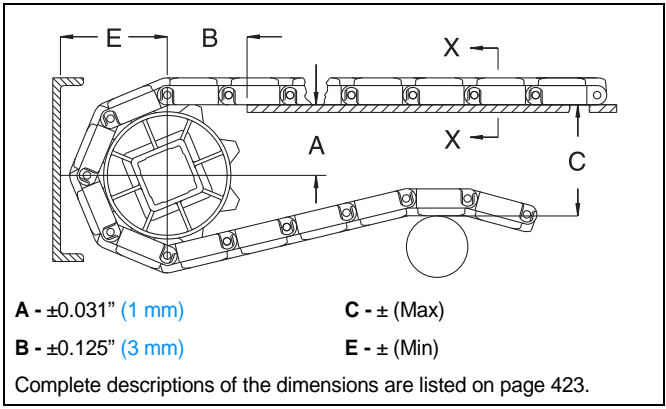

Sprocket Description			A		B		C		E	
Pitch Diameter		No. Teeth	Range (Bottom to Top)		in.	mm	in.	mm	in.	mm
in.	mm		in.	mm						
SERIES 1100 FLUSH GRID, FLAT TOP, PERFORATED FLAT TOP^a, EMBEDDED DIAMOND TOP										
1.6	41	8	0.53-0.59	13-15	1.02	26	1.70	43	1.00	25
2.3	58	12	0.93-0.97	24-25	1.31	33	2.40	61	1.37	35
3.1	79	16	1.31	33	1.51	38	3.20	81	1.75	44
3.5	89	18	1.51	38	1.66	42	3.60	91	1.94	49
3.8	97	20	1.70	43	1.77	45	3.79	96	2.13	54
4.6	117	24	2.08	53	1.92	49	4.75	121	2.60	66
5.1	130	26	2.28	58	1.96	50	5.14	131	2.73	69
6.1	155	32	2.85	72	2.20	56	6.20	155	3.30	84
SERIES 1100 FLUSH GRID FRICTION TOP^a, FLUSH GRID FRICTION TOP, NO INDENT^a										
1.6	41	8	0.53-0.59	13-15	1.04	27	1.61	41	1.08	27
2.3	58	12	0.93-0.97	24-25	1.30	33	2.36	60	1.46	37
3.1	79	16	1.31	33	1.55	39	3.12	79	1.84	47
3.5	89	18	1.51	38	1.66	42	3.50	89	2.03	51
3.8	97	20	1.70	43	1.77	45	3.88	98	2.22	56
4.6	117	24	2.08	53	1.97	50	4.64	118	2.60	66
5.1	130	26	2.28	58	2.06	52	5.02	127	2.79	71
6.1	155	32	2.85	72	2.25	57	6.16	157	3.36	85

Sprocket Description		A		B		C		E		
Pitch Diameter		No. Teeth	Range (Bottom to Top)		in.	mm	in.	mm	in.	mm
in.	mm		in.	mm						
SERIES 1100 FLUSH GRID NUB TOP^a										
1.6	41	8	0.53-0.59	13-15	1.04	27	1.57	40	1.05	27
2.3	58	12	0.93-0.97	24-25	1.30	33	2.32	59	1.42	36
3.1	79	16	1.31	33	1.55	39	3.08	78	1.80	46
3.5	89	18	1.51	38	1.66	42	3.46	88	1.99	51
3.8	97	20	1.70	43	1.70	43	3.84	98	2.18	55
4.6	117	24	2.08	53	1.97	50	4.60	117	2.56	65
5.1	130	26	2.28	58	2.06	52	4.98	127	2.75	70
6.1	155	32	2.85	72	2.25	57	6.13	156	3.32	84
SERIES 1100 CONE TOP^a										
1.6	41	8	0.54-0.60	14-15	1.04	26	1.66	42	1.13	29
2.3	58	12	0.93-0.97	24-25	1.30	33	2.41	61	1.50	38
3.1	79	16	1.32	34	1.55	39	3.17	81	1.88	48
3.5	89	18	1.51	38	1.66	42	3.55	90	2.07	53
3.8	97	20	1.71	43	1.70	43	3.93	100	2.26	57
4.6	117	24	2.09	53	1.96	50	4.69	119	2.64	67
5.1	130	26	2.28	58	2.05	52	5.07	129	2.83	72
6.1	155	32	2.86	73	2.24	57	6.22	158	3.41	87

a. Refer to "Anti-sag carryway wearstrip configuration" (page 428) for alternative layouts for the "B" dimension.

Dead Plate Gap

Where there is a transfer point from a belt without finger transfer plates to a dead plate, there should be a gap between the surfaces to allow for the chordal action of the belt. As the belt engages its sprockets, chordal action causes the modules to move past a *fixed* point (the tip of the dead plate) with *varying* clearances. The table below shows the minimum amount of gap which occurs at the "low point" of the modules if the tip of the dead plate just comes in contact with the "high point" as the modules pass.

In some installations it may be desirable to keep the tip of the dead plate in contact with the belt, rather than allow a gap to occur. This can be done by hinging the mounting bracket for the dead plate. This allows the dead plate to move as the modules pass, but results in a small oscillating motion which may present tippage problems for sensitive containers or products.

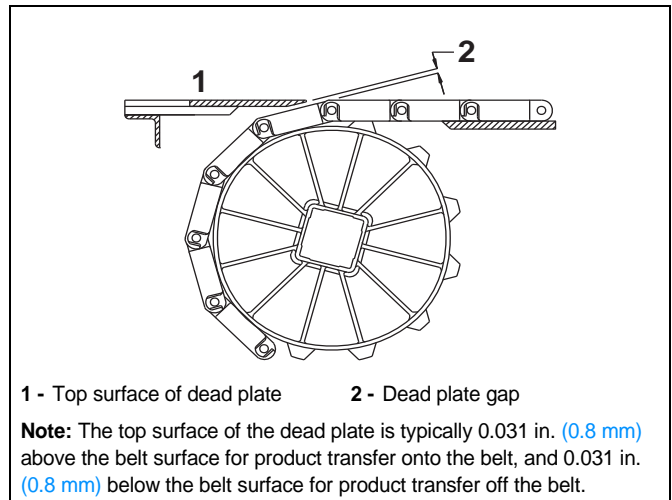

Sprocket Description			Gap	
Pitch Diameter		No. Teeth	in.	mm
in.	mm			
1.6	41	8	0.058	1.5
2.3	58	12	0.040	1.0
3.1	79	16	0.029	0.7
3.5	89	18	0.026	0.7
3.8	97	20	0.024	0.6
4.6	117	24	0.020	0.5
5.1	130	26	0.018	0.4
6.1	155	32	0.015	0.4

Flush Grid		
	in	mm
Pitch	1.44	36.6
Minimum Width	6	152
Width Increments	1.00	25.4
Opening Size (approximate)	-	-
Open Area	24%	
Hinge Style	Closed	
Drive Method	Center-driven	
Product Notes		
<ul style="list-style-type: none"> Contact Intralox for precise belt measurements and stock status before designing equipment or ordering a belt. Module thickness is 0.75 in (19.1 mm) which provides superior belt strength and stiffness. Improved Slidelox® rod retention system. Uses headless rods. Molded split plastic sprockets available for easy installation. Made of engineered resin for increased stiffness and minimal belt elongation through thermal expansion. Slidelox is glass reinforced polypropylene. 		
Additional Information		
<ul style="list-style-type: none"> See "Belt Selection Process" (page 5) See "Standard Belt Materials" (page 9) See "Special Application Belt Materials" (page 9) See "Friction Factors" (page 13) 		

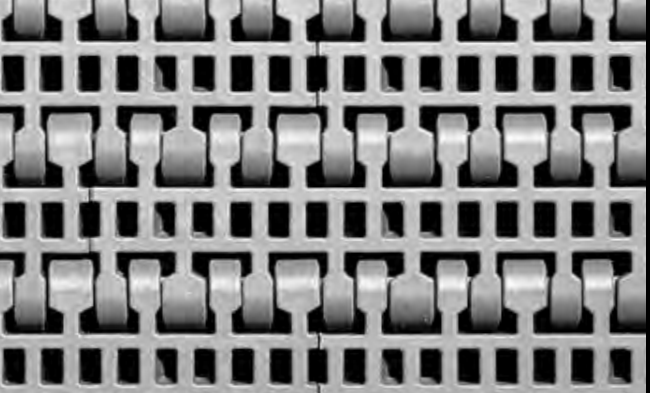
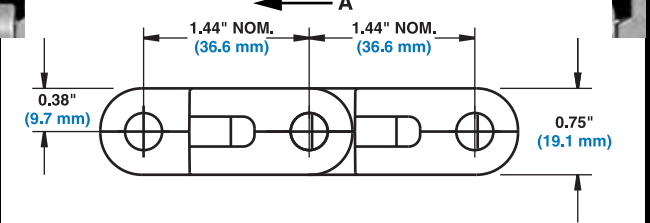
A -Preferred run direction

Belt Data							
Belt Material	Standard Rod Material Ø 0.31 in (7.9 mm)	BS Belt Strength ^a		Temperature Range (continuous)		W Belt Weight	
		lb/ft	kg/m	°F	°C	lb/ft ²	kg/m ²
Polypropylene Composite	Polypropylene	3300	4908	34 to 220	1 to 104	2.87	14.01

a. Belt strength rating is dependent on belt's preferred running direction. If run in the opposite direction, the belt rating is 2000 lb/ft (3000 kg/m).

Flat Top

	in	mm
Pitch	1.44	36.6
Minimum Width	6	152
Width Increments	1.00	25.4
Opening Size (approximate)	-	-
Open Area	0%	
Hinge Style	Closed	
Drive Method	Center-driven	

Product Notes

- **Contact Intralox for precise belt measurements and stock status before designing equipment or ordering a belt.**
- Module thickness is 0.75 in (19.1 mm) provides superior belt strength and stiffness. In the preferred running direction, the Series 1200 belts are rated at 4000 lb/ft (5950 kg/m).
- Improved Slidelox® rod retention system.
- Uses headless rods.
- Molded split plastic sprockets available for easy installation.
- Made of engineered resin for increased stiffness and minimal belt elongation through thermal expansion.
- Belt strength rating is dependent on belt's preferred running direction. If run in the opposite direction, the belt rating is 2000 lb/ft (3000 kg/m). The belt strength for narrow belts is reduced to 3750 lb/ft (5580 kg/m) for belt widths under 60 in (1524 mm), 3250 lb/ft (4835 kg/m) for belt widths under 30 in (762 mm), and 2750 lb/ft (4090 kg/m) for belt widths under 12 in (305 mm). Contact Customer Service if a more precise belt strength is required for belt widths under 60 in (1524 mm).
- Slidelox is glass reinforced polypropylene.

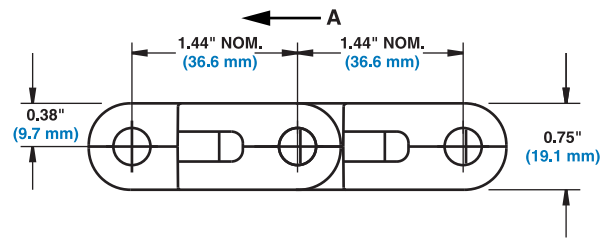
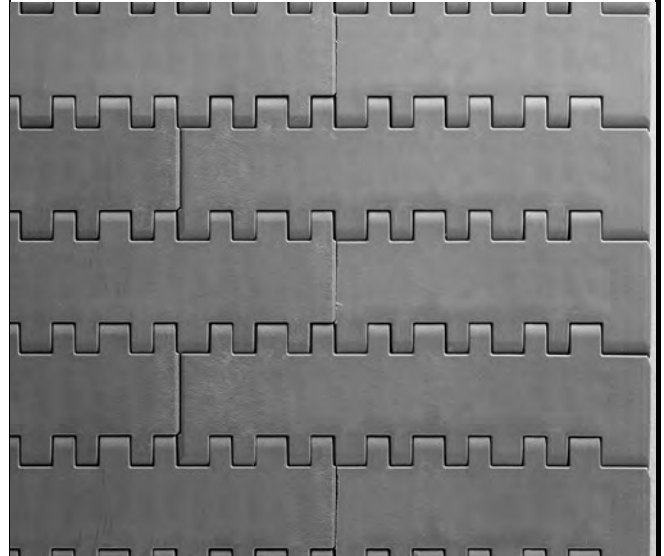

A -Preferred run direction

Additional Information

- See "Belt Selection Process" (page 5)
- See "Standard Belt Materials" (page 9)
- See "Special Application Belt Materials" (page 9)
- See "Friction Factors" (page 13)

Belt Data

Belt Material	Standard Rod Material Ø 0.31 in (7.9 mm)	BS		Temperature Range (continuous)		W	
		Belt Strength ^a lb/ft	kg/m	°F	°C	Belt Weight lb/ft ²	kg/m ²
Polypropylene Composite	Polypropylene Composite	4000	5950	-20 to 220	-29 to 104	3.17	15.45
EC Polypropylene Composite	Polypropylene Composite	4000	5950	-20 to 220	-29 to 104	3.2	15.66

a. Belt strength rating is dependent on belt's preferred running direction. If run in the opposite direction, the belt rating is 2000 lb/ft (3000 kg/m). The belt strength for narrow belts is reduced to 3750 lb/ft (5580 kg/m) for belt widths under 60 in (1524 mm), 3250 lb/ft (4835 kg/m) for belt widths under 30 in (762 mm), and 2750 lb/ft (4090 kg/m) for belt widths under 12 in (305 mm). Contact Customer Service if a more precise belt strength is required for belt widths under 60 in (1524 mm).

Raised Rib		
	in	mm
Pitch	1.44	36.6
Minimum Width	6	152
Width Increments	1.00	25.4
Open Area	24%	
Product Contact Area	24%	
Hinge Style	Closed	
Drive Method	Center-driven	
Product Notes		
<ul style="list-style-type: none"> • Contact Intralox for precise belt measurements and stock status before designing equipment or ordering a belt. • Module thickness is 1.0 in (25.4 mm) provides superior belt strength and stiffness. • Improved Slidelox® rod retention system. • Uses headless rods. • Molded split plastic sprockets available for easy installation. • Made of engineered resin for increased stiffness and minimal belt elongation through thermal expansion. • Slidelox is glass reinforced polypropylene. 		
Additional Information		
<ul style="list-style-type: none"> • See "Belt Selection Process" (page 5) • See "Standard Belt Materials" (page 9) • See "Special Application Belt Materials" (page 9) • See "Friction Factors" (page 13) 		

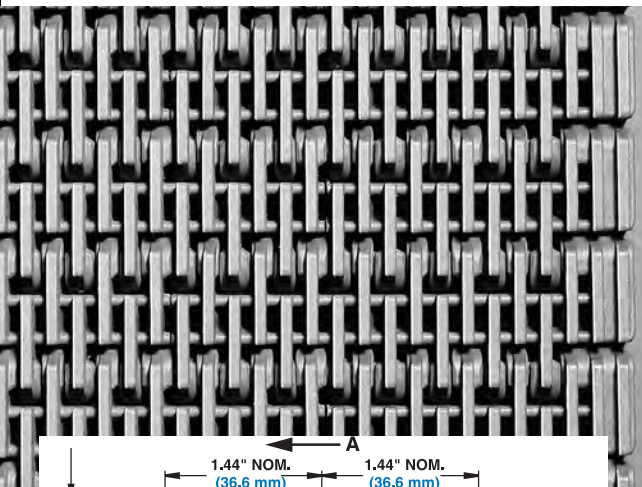

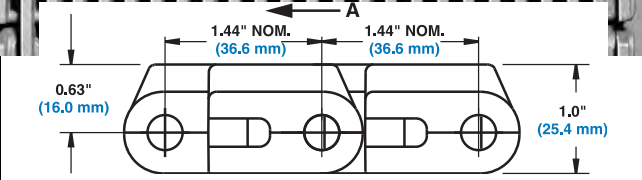
A -Preferred run direction

Belt Data							
Belt Material	Standard Rod Material Ø 0.31 in (7.9 mm)	BS Belt Strength ^a		Temperature Range (continuous)		W Belt Weight	
		lb/ft	kg/m	°F	°C	lb/ft ²	kg/m ²
Polypropylene Composite	Polypropylene	3300	4908	34 to 220	1 to 104	3.3	16.11

a. Belt strength rating is dependent on belt's preferred running direction. If run in the opposite direction, the belt rating is 2000 lb/ft (3000 kg/m).

Non Skid

	in	mm
Pitch	1.44	36.6
Minimum Width	6	152
Width Increments	1.00	25.4
Opening Size (approximate)	-	-
Open Area	0%	
Hinge Style	Closed	
Drive Method	Center-driven	



Product Notes

- **Contact Intralox for precise belt measurements and stock status before designing equipment or ordering a belt.**
- Module thickness is 0.75 in (19.1 mm) provides superior belt strength and stiffness. In the preferred running direction, the Series 1200 belts are rated at 4000 lb/ft (5950 kg/m).
- Improved Slidelox® rod retention system.
- Uses headless rods.
- Molded split plastic sprockets available for easy installation.
- Made of engineered resin for increased stiffness and minimal belt elongation through thermal expansion; this static dissipative material does not rely on moisture to dissipate a charge, so it is effective in all environments.
- 1.44 in (36.6 mm) pitch allows use of smaller drive sprockets than traditional “moving platform” belts, thus providing tighter transfers and requiring shallower floor trenches for installation.
- Non Skid indent is 1.0 in (25.4 mm).
- Slidelox is glass reinforced polypropylene.

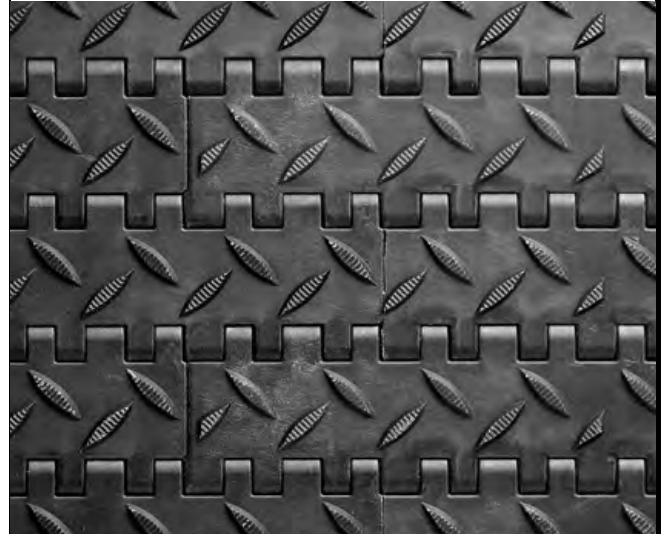

Additional Information

- See “Belt Selection Process” (page 5)
- See “Standard Belt Materials” (page 9)
- See “Special Application Belt Materials” (page 9)
- See “Friction Factors” (page 13)

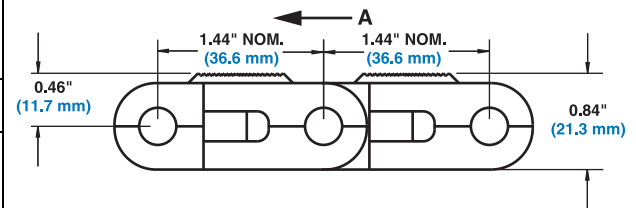

A -Preferred run direction

Belt Data

Belt Material	Standard Rod Material Ø 0.31 in (7.9 mm)	BS		Temperature Range (continuous)		W	
		Belt Strength ^a lb/ft	kg/m	°F	°C	Belt Weight lb/ft ²	kg/m ²
EC Polypropylene Composite	Polypropylene Composite	4000	5950	-20 to 220	-29 to 104	3.21	15.65

a. Belt strength rating is dependent on belt's preferred running direction. If run in the opposite direction, the belt rating is 2000 lb/ft (3000 kg/m). The belt strength for narrow belts is reduced to 3750 lb/ft (5580 kg/m) for belt widths under 60 in (1524 mm), 3250 lb/ft (762 kg/m) for belt widths under 30 in (762 mm), and 2750 lb/ft (4090 kg/m) for belt widths under 12 in (305 mm). Contact Customer Service if a more precise belt strength is required for belt widths under 60 in (1524 mm).

Non Skid Raised Rib		
	in	mm
Pitch	1.44	36.6
Minimum Width	6	152
Width Increments	1.00	25.4
Opening Size (approximate)	-	-
Open Area	0%	
Product Contact Area	10%	
Hinge Style	Closed	
Drive Method	Center-driven	
Product Notes		
<ul style="list-style-type: none"> • Contact Intralox for precise belt measurements and stock status before designing equipment or ordering a belt. • Made of engineered resin for increased stiffness and minimal belt elongation through thermal expansion; this static dissipative material does not rely on moisture to dissipate a charge, so it is effective in all environments. • 1.44 in (36.6 mm) pitch allows use of smaller drive sprockets than traditional "moving platform" belts, thus providing tighter transfers and requiring shallower floor trenches for installation. • Uses Slidelox® rod retention system. • Uses headless rods. • Tread pattern provides a non-skid walking surface to increase safety. • Staggered yellow edges make it easy to distinguish the moving belt from the stationary floor. • Not recommended for back-up conditions. If friction values between product and belt are required, contact Intralox Sales Engineering. • Rib indent is 1.0 in (25 mm). • Slidelox is glass reinforced polypropylene. 		
Additional Information		
<ul style="list-style-type: none"> • See "Belt Selection Process" (page 5) • See "Standard Belt Materials" (page 9) • See "Special Application Belt Materials" (page 9) • See "Friction Factors" (page 13) 		

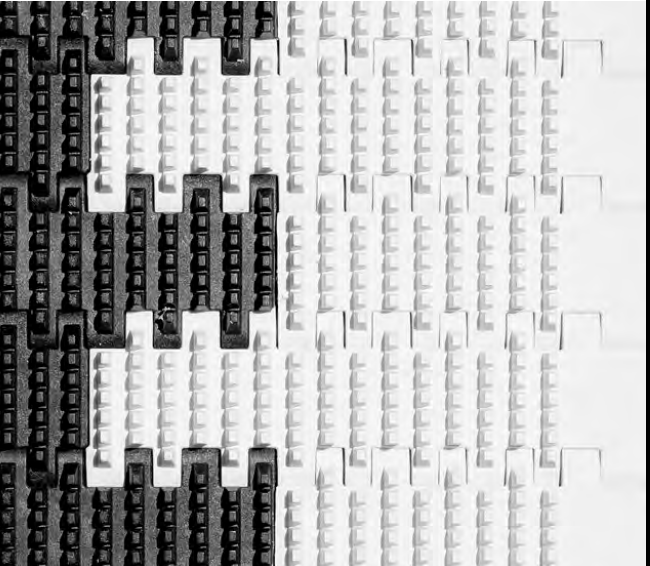

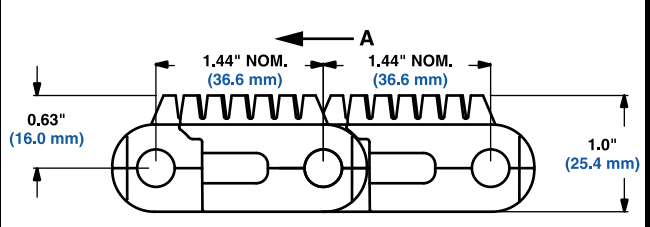
A - Preferred run direction

Belt Data							
Belt Material	Standard Rod Material Ø 0.31 in (7.9 mm)	BS Belt Strength ^a		Temperature Range (continuous)		W Belt Weight	
		lb/ft	kg/m	°F	°C	lb/ft ²	kg/m ²
EC Polypropylene Composite	Polypropylene Composite	4000	5950	-20 to 220	-29 to 104	3.58	17.48
UV Resistant Acetal ^b	Acetal	2500	3713	-50 to 150	-46 to 66	4.51	22.02

- a. Belt strength rating is dependent on belt's preferred running direction. If run in the opposite direction, the belt rating is 2000 lb/ft (3000 kg/m). The belt strength for narrow belts is reduced to 3750 lb/ft (5580 kg/m) for belt widths under 60 in (1524 mm), 3250 lb/ft (762 kg/m) for belt widths under 30 in (762 mm), and 2750 lb/ft (4090 kg/m) for belt widths under 12 in (305 mm). Contact Customer Service if a more precise belt strength is required for belt widths under 60 in (1524 mm).
- b. UV Resistant Acetal requires special sprockets. Please contact Customer Service when ordering sprocket for this belt.

Sprocket and Support Quantity Reference

Belt Width Range ^a		Minimum Number of Sprockets Per Shaft ^b	Wearstrips	
in.	mm		Carryway	Returnway
6	152	2	2	2
7	178	2	2	2
8	203	2	2	2
9	229	2	2	2
10	254	2	3	2
12	305	3	3	2
14	356	3	3	3
15	381	3	3	3
16	406	3	3	3
18	457	3	3	3
20	508	3	4	3
24	610	5	4	3
30	762	5	5	4
32	813	5	5	4
36	914	7	5	4
42	1067	7	6	5
48	1219	9	7	5
54	1372	9	7	6
60	1524	11	8	6
72	1829	13	9	7
84	2134	15	11	8
96	2438	17	12	9
120	3048	21	15	11
144	3658	25	17	13
145	3683	25	18	14
146	3708	25	18	14
147	3734	25	18	14
148	3759	25	18	14
149	3785	25	18	14
150	3810	25	18	14
151	3835	25	18	14
152	3861	25	18	14
153	3886	25	18	14
154	3912	25	19	14
155	3937	25	19	14
156	3962	27	19	14
157	3988	27	19	15
158	4013	27	19	15
159	4039	27	19	15
160	4064	27	19	15
161	4089	27	19	15
162	4115	27	19	15
163	4140	27	20	15
164	4166	27	20	15
165	4191	27	20	15

For Other Widths, Use Odd Number of Sprockets^c at
Maximum 6 in. (152 mm) \varnothing Spacing

Maximum 6 in. (152 mm) \varnothing Spacing

Maximum 12 in. (305 mm) \varnothing Spacing

Sprocket and Support Quantity Reference				
Belt Width Range ^a		Minimum Number of Sprockets Per Shaft ^b	Wearstrips	
in.	mm		Carryway	Returnway
166	4216	27	20	15
167	4242	27	20	15
168	4267	29	20	15
169	4293	29	20	16
170	4318	29	20	16
171	4343	29	20	16
172	4369	29	21	16
173	4394	29	21	16
174	4420	29	21	16
175	4445	29	21	16
176	4470	29	21	16
177	4496	29	21	16
178	4521	29	21	16
179	4547	29	21	16
180	4572	31	21	16
181	4597	31	22	17
182	4623	31	22	17
183	4648	31	22	17
184	4674	31	22	17
185	4699	31	22	17
For Other Widths, Use Odd Number of Sprockets ^c at Maximum 6 in. (152 mm) \varnothing Spacing			Maximum 6 in. (152 mm) \varnothing Spacing	Maximum 12 in. (305 mm) \varnothing Spacing

- If your belt width exceeds a number listed in the table, please refer to the sprocket and support material minimums for the next larger width range listed. Belts are available in 1.00 in. (25.4 mm) increments beginning with minimum width of 6 in. (152 mm). If the actual width is critical, consult Customer Service.
- These are the minimum number of sprockets. Additional sprockets may be required for heavily loaded applications.
- The center sprocket should be locked down. With only two sprockets, fix the sprocket on the drive journal side only. See Locked Sprocket Location chart in the Installation Instruction Guidelines or call Customer Service for lock down location.

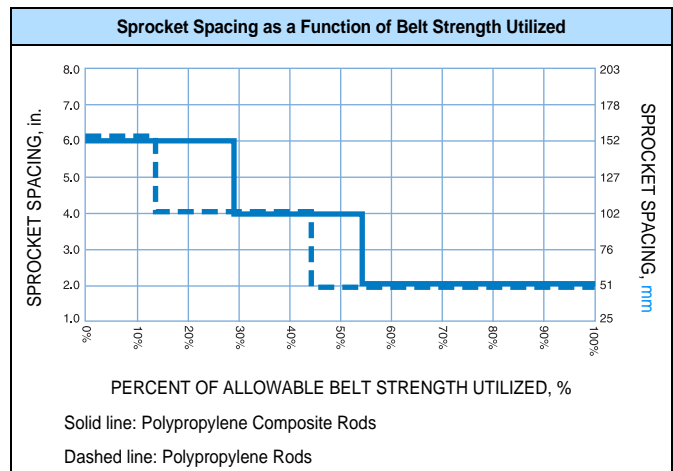
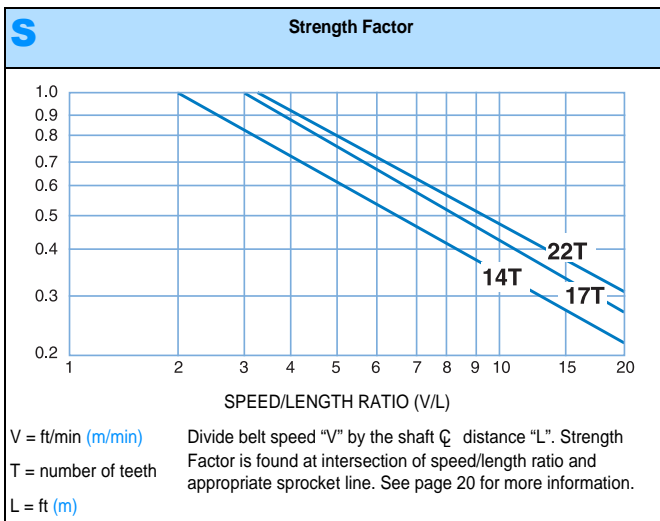

Plastic Split Sprocket^a

No. of Teeth (Chordal Action)	Nom. Pitch Dia. in	Nom. Pitch Dia. mm	Nom. Outer Dia. in	Nom. Outer Dia. mm	Nom. Hub Width in	Nom. Hub Width mm	Available Bore Sizes			
							U.S. Sizes		Metric Sizes	
							Round in ^b	Square in ^c	Round mm ^b	Square mm
14 (2.51%)	6.5	165	6.3	161	1.5	38		1.5		
								2.5		
17 (1.70%)	7.9	201	7.7	196	1.5	38		2.5		
22 (1.02%)	10.2	259	10.1	255	1.67	44		2.5		
					1.5	38	3.5	3.5		90



a. Contact Customer Service for lead times.

b. Imperial key sizes on round bore sprockets conform to ANSI standard B17.1-1967 (R1989) and metric key sizes conform to DIN standard 6885.

c. The 2.5" square bore is created by using a bore adapter in the 3.5" square bore sprocket.

Split Metal Sprocket^a

No. of Teeth (Chordal Action)	Nom. Pitch Dia. in	Nom. Pitch Dia. mm	Nom. Outer Dia. in	Nom. Outer Dia. mm	Nom. Hub Width in	Nom. Hub Width mm	Available Bore Sizes			
							U.S. Sizes		Metric Sizes	
							Round in	Square in	Round mm	Square mm
12 (3.41%)	5.6	142	5.4	137	1.7	43		2.5		
14 (2.51%)	6.5	165	6.3	161	1.7	43		2.5		
22 (1.70%)	10.2	259	10.1	255	1.7	43		2.5		
								3.5		

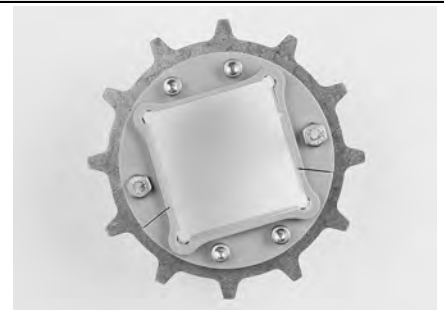

a. Contact Customer Service for lead times.

Hold Down Tabs

Note: The strength rating for each Hold Down Tab is 100 lbs (45.4 kg) of force perpendicular to the hold down surface.

Note: Tabs should be spaced every other row (2.9 inches [73.2 mm]) along the length of the belt. Tabs can be spaced every fourth row (5.8 inches [146.3 mm]) for lightly loaded applications.

Note: Each line of tabs along the length of the belt reduces the available number of sprockets by 2. Belt rating is reduced by 1,300 lbs (590 kg) for each line of tabs.

Note: Carryway wearstrip or rollers that engage the tabs are only required at the transition between the horizontal sections and angled sections. This reduces initial system cost, as well as ongoing maintenance cost and effort.

Note: Care should be taken to ensure that adequate lead-in radii and/or angles are used to prevent the possibility of snagging the tab on the frame.

Note: A carryway radius should be designed at the transition between horizontal sections and angled sections. This radius must be at least 48 inches (1.22 m) for belts that will be loaded near the belt's strength rating. This radius is one of the most important factors to take into consideration when designing highly loaded conveyors that utilize Hold Down Tabs.

Note: Available on Non Skid and Flat Top belts.



Insert Nuts				
Available Base Belt Style - Material			Available Insert Nut Sizes	
Series 1200 Flat Top - Polypropylene Composite			5/16" - 18 (8 mm - 1.25 mm)	
Belt Material	Maximum Fixture Weight		Fastener Torque Specification	
	lbs/nut ^a	kg/nut ^a	in-lbs	N-m
Polypropylene Composite	355	155	100	11.3



Note: Insert Nuts easily allow the attachment of fixtures to the belt.

Note: Nut placement constraints are as follows; 5/6" (21 mm) minimal indent from the edge of the belt for odd width belts and 1-5/6" (47 mm) minimal indent for even width belts, 1-1/3" (34 mm) minimal distance between nuts across the width of the belt and spacing along the length of the belt is in 1.44" (36.6 mm) increments.

Note: All nut placement dimensions are referenced from the edge of the belt when placing an order. Contact Intralox Customer Service for nut location options available for your individual belt specifications.

Note: Attachments that are connected to more than one row must not prohibit the rotation of the belt around the sprockets.

Note: Sprockets cannot be located in-line with the locations of the insert nuts in the belt.

Note: For attachment bases that extend across multiple rows, considerations should be made to accommodate for reduced backbend.

a. This is fixture weight only. Product weight need not be included.

Finger Transfer Plates			
Available Widths		Number of Fingers	Available Materials
in	mm		
6	152	18	Polypropylene

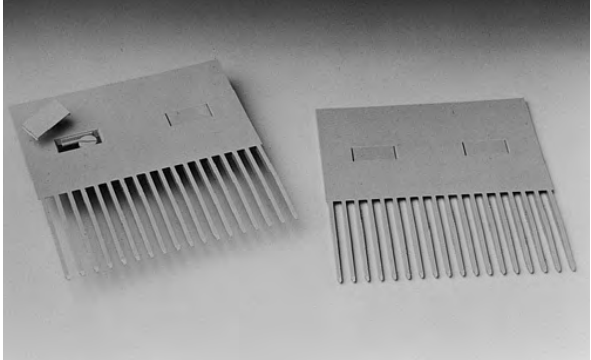

Note: Eliminates product transfer and tipping problems. The 18 fingers extend between the belt's ribs allowing a smooth continuation of the product flow as the belt engages its sprockets.

Note: Easily installed on the conveyor frame with the shoulder bolts supplied. Caps snap easily into place over the bolts, keeping foreign materials out of the slots.

Note: The Finger Transfer Plates for Series 400 are the same for Series 1200.

Two-Material Finger Transfer Plates

Available Widths		Number of Fingers	Available Materials
in	mm		
6	152	18	Glass-Filled Thermoplastic Fingers, Acetal Backplate

Note: Plates provide high strength fingers combined with a low friction back plate.

Note: Low-friction back plate is permanently attached to the two high-strength finger inserts.

Note: Eliminates product transfer and tipping problems. The 18 fingers extend between the belt's ribs allowing a smooth continuation of the product flow as the belt engages its sprockets.

Note: Plastic shoulder bolts and bolt covers are included for installing the standard two-material FTPs.

Note: Mounting hardware for the Glass Handling two-material FTPs is sold separately and consists of stainless steel oval washers and bolts, which give more secure fastening for the tough glass applications.

Note: The Finger Transfer Plates for Series 400 are the same for Series 1200.

Note: Available in three different configurations:

Standard - long fingers with a short back plate.

Standard Extended Back - long fingers with an extended back plate

Glass Handling -

- Short fingers with extended back plate
- Short fingers/short back (Contact Customer Service for lead times.)
- Mid-Length fingers/short back
- Mid-Length fingers/extended back

The long fingers provide good support for unstable products like PET containers and cans. The short fingers are sturdy enough for even the harshest broken glass applications. These fingers are designed to resist breaking, but if confronted with deeply embedded glass, the individual fingers will yield and break off, preventing costly belt or frame damage. The short back plate has two attachment slots and the extended back plate has three attachment slots.

Note: For best product transfer, 10.2 in (259 mm) PD, 22 tooth sprockets are recommended for use with Glass Handling finger transfer plates. The 10.2 in (259 mm) PD 22 tooth sprockets are also the maximum size sprockets to use with short finger Glass Handling finger transfer plates.

Note: Intralox also offers a single-material polypropylene standard finger transfer plate for better chemical resistance. Mounting hardware for this FTP includes plastic shoulder bolts and snap-cap bolt covers.

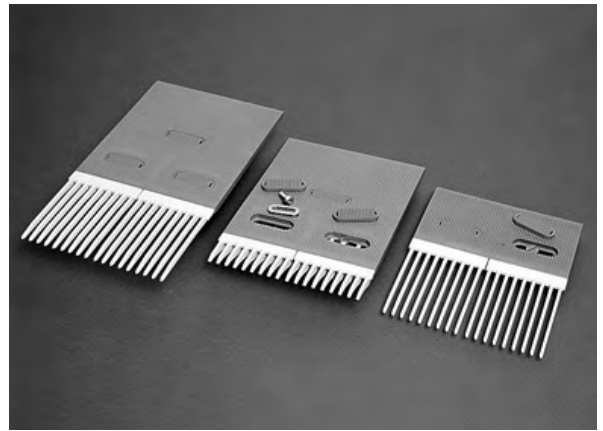

Dimensional Requirements for Finger Transfer Plate Installation

	Two-Material							
	Standard Long Fingers - Short Back		Standard Long Fingers - Extended Back		Glass Handling Short Fingers - Extended Back		Glass Handling Mid-Length Fingers - Extended Back	
	in	mm	in	mm	in	mm	in	mm
F	3.50	89	3.50	89	3.50	89	3.50	89
G	0.31	8	0.31	8	0.31	8	0.31	8
H	7.25	184	10.75	273	8.26	210	9.04	230
I	5.91	150	5.91	150	5.91	150	5.91	150
J	3.00	76	3.00	76	3.00	76	3.00	76
K	1.45	37	1.45	37	1.45	37	1.45	37
L	2.00	51	5.50	140	5.50	140	5.50	140
Spacing at ambient temperature	Polypropylene Composite							
	6.0	152.4	6.0	152.4	6.0	152.4	6.0	152.4

Two-material glass handling finger transfer plate shown

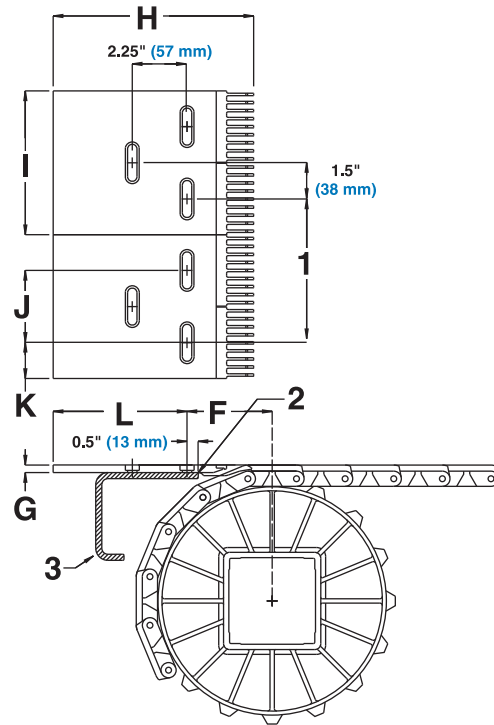

- 1 - SPACING
- 2 - 0.5" (13 mm) RADIUS (LEADING EDGE OF FRAME MEMBER)
- 3 - FRAME MEMBER

Self-Clearing Finger Transfer Plates^a

Available Width		Number of Fingers	Available Materials
in	mm		
6	152	18	Glass-Filled Thermoplastic

Note: The Self-Clearing Finger Transfer System consists of a finger transfer plate and a transfer edge belt that are designed to work together. This system eliminates the need for a sweeper bar, a pusher arm, or wide transfer plates. Transfers are smooth and 100% self-clearing, making right angle transfers possible for all container types. The Self-Clearing Finger Transfer System is ideal for warmer/cooler applications with frequent product changeovers and is compatible with any series and style of Intralox belt on the discharge and infeed conveyors. This system is bi-directional allowing the same transfer belt to be used for both left-hand and right-hand transfers.

Note: Self-Clearing Finger Transfer System is capable of transferring product to and from Intralox Series 400, Series 1200 and Series 1900 Raised Rib belts.

Note: Smooth, flat top surface provides excellent lateral movement of containers.

Note: Robust design for durability in tough glass applications.

Note: Finger Transfer Plates are easily installed and secured to mounting plates of any thickness with stainless steel bolts and oval washers that allow movement with the belt's expansion and contraction.

Note: Stainless steel hardware is sold separately.

Note: Self-Clearing Transfer Edge Belt is molded with robust tracking tabs for belt support in heavy side-loading conditions. It has fully flush edges, headed rod retention system and nylon rods for superior wear resistance.



a. Licensed under Rexnord U.S. Patent Nos. 7,314,130 and 7,448,490

Dimensional Requirements for Self-Clearing Finger Transfer Plate Installations^a

	Self-Clearing	
	in	mm
F	5.25	133.4
G	1.15	29.2
H	8.05	204.5
I	5.93	150.6
J	2.92	74.2
K	1.51	38.4
L	2.71	68.8
Spacing at ambient temperature		
PP Composite	6.000 in	152.4 mm

1 - Spacing
2 - Frame Member

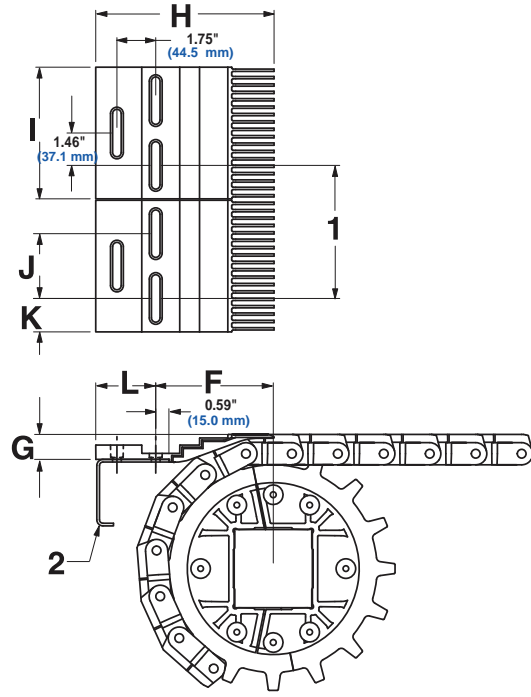

a. Licensed under Rexnord U.S. Patent Nos. 7,314,130 and 7,448,490

Conveyor Frame Dimensions

Regardless of type or configuration, all conveyors using Intralox belts have some basic dimensional requirements. Specifically, dimensions "A", "B", "C" and "E" listed below should be implemented in any design.

For general applications and applications where end transfer of tip-sensitive product is not critical, use the "A" dimension at the bottom of the range.

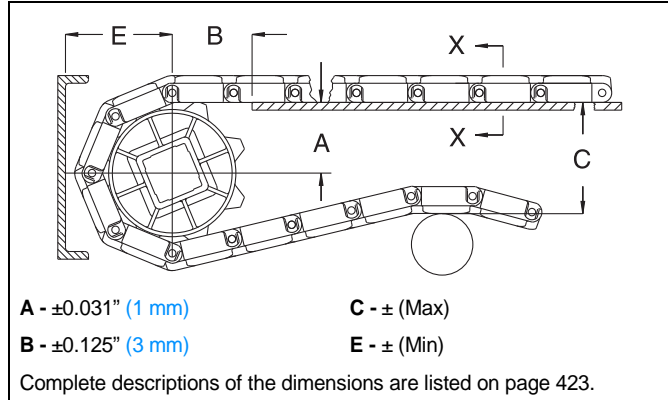

Sprocket Description			A		B		C		E	
Pitch Diameter		No. Teeth	Range (Bottom to Top)		in.	mm	in.	mm	in.	mm
in.	mm		in.	mm						
SERIES 1200 FLUSH GRID, FLAT TOP										
5.6	142	12	2.31-2.41	59-61	2.15	55	5.56	141	3.22	82
6.5	165	14	2.78-2.87	71-73	2.35	60	6.48	165	3.87	98
7.9	201	17	3.48-3.55	88-90	2.62	67	7.85	199	4.55	116
10.2	259	22	4.64-4.69	118-119	3.02	77	10.13	257	5.69	145
SERIES 1200 RAISED RIB, NON-SKID RAISED RIB										
5.6	142	12	2.31-2.41	59-61	2.15	55	5.81	148	3.47	88
6.5	165	14	2.78-2.87	71-73	2.35	60	6.73	171	4.12	105
7.9	201	17	3.48-3.55	88-90	2.62	67	8.10	206	4.80	122
10.2	259	22	4.64-4.69	118-119	3.02	77	10.38	264	5.94	151
SERIES 1200 NON SKID										
5.6	142	12	2.31-2.41	59-61	2.15	55	5.65	144	3.30	84
6.5	165	14	2.78-2.86	71-73	2.34	59	6.56	167	3.76	96
7.9	201	17	3.51-3.58	89-91	2.57	65	7.99	203	4.47	114
10.2	259	22	4.67-4.73	119-120	3.02	77	10.29	261	5.62	143

Dead Plate Gap

Where there is a transfer point from a belt without finger transfer plates to a dead plate, there should be a gap between the surfaces to allow for the chordal action of the belt. As the belt engages its sprockets, chordal action causes the modules to move past a *fixed* point (the tip of the dead plate) with *varying* clearances. The table below shows the minimum amount of gap which occurs at the “low point” of the modules if the tip of the dead plate just comes in contact with the “high point” as the modules pass.

In some installations it may be desirable to keep the tip of the dead plate in contact with the belt, rather than allow a gap to occur. This can be done by hinging the mounting bracket for the dead plate. This allows the dead plate to move as the modules pass, but results in a small oscillating motion which may present tippage problems for sensitive containers or products.

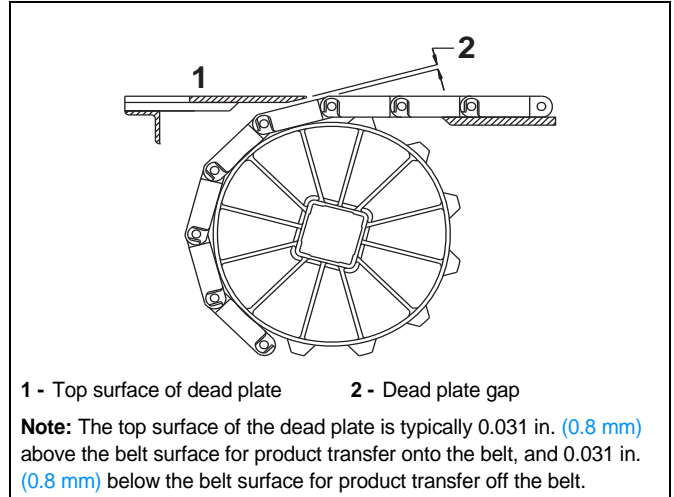

Sprocket Description		Gap		
Pitch Diameter		No. Teeth		
in.	mm		in.	mm
5.6	142	12	.095	2.4
6.5	165	14	.081	2.1
7.9	201	17	.067	1.7
10.2	259	22	.052	1.3

Flat Top		
	in	mm
Pitch	1.00	25.4
Minimum Width	5	127
Width Increments	1.00	25.4
Opening Size (approximate)	-	-
Open Area	0%	
Hinge Style	Closed	
Drive Method	Center/hinge-driven	

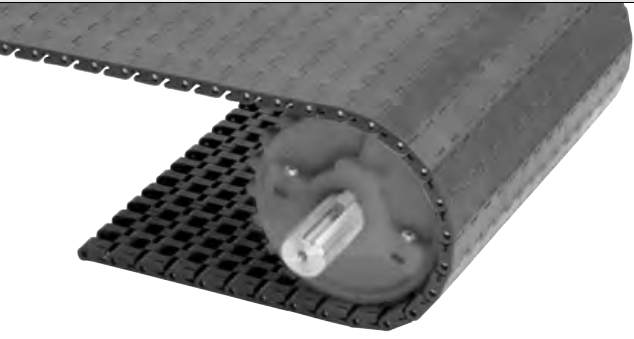

Product Notes

- Contact Intralox for precise belt measurements and stock status before designing equipment or ordering a belt.
- Smooth, closed surface with fully flush edges.
- Uses headless rods.
- Robust design offers excellent belt and sprocket durability, especially in tough glass applications.
- Smooth, flat top provides excellent lateral movement of containers. Ideal for container handling.
- Most Series 1400 sprockets use the split design so shafts do not have to be removed for retrofits and changeovers. The Series 1400 sprockets are all plastic.
- The Series 1400 split sprockets are designed with thick, "lug" style teeth for excellent durability and wear life.
- Uses Slidelox® rod retention system. Slidelox is available in polypropylene or acetal.
- Easy Release PLUS uses a polypropylene Slidelox.
- Easy Release Traceable Polypropylene uses a detectable polypropylene Slidelox.

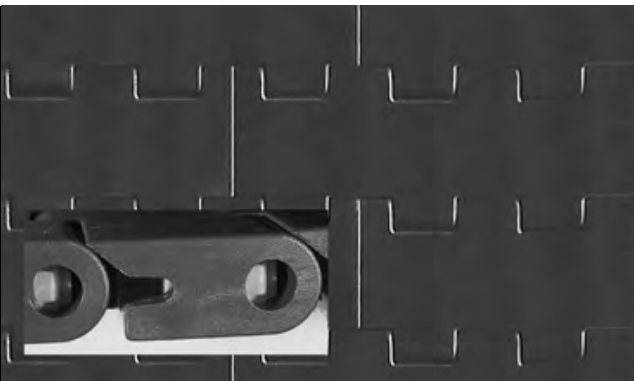

Inset: Slidelox® Edge

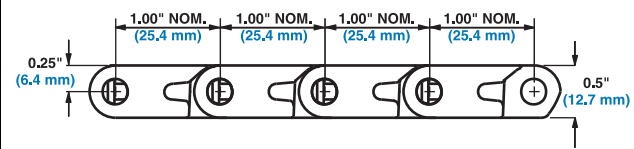

Additional Information

- See "Belt Selection Process" (page 5)
- See "Standard Belt Materials" (page 9)
- See "Special Application Belt Materials" (page 9)
- See "Friction Factors" (page 13)

Belt Data							
Belt Material	Standard Rod Material Ø 0.24 in (6.1 mm)	BS Belt Strength		Temperature Range (continuous)		W Belt Weight	
		lb/ft	kg/m	°F	°C	lb/ft ²	kg/m ²
Acetal	Nylon	2500	3720	-50 to 200	-46 to 93	2.75	13.43
Polypropylene	Nylon	1800	2678	34 to 220	1 to 104	1.85	9.03
HHR Nylon	Nylon	2000	2976	-50 to 310	-46 to 154	2.32	11.33
HSEC Acetal	Nylon	1600	2380	-50 to 200	-46 to 93	2.69	13.13

Mold to Width Flat Top		
	in	mm
Pitch	1.00	25.4
Molded Widths	3.25	83
	4.5	114
	6.0	152
	7.5	191
	-	85.0
Opening Size (approximate)	-	-
Open Area	0%	
Hinge Style	Closed	
Drive Method	Center/hinge-driven	
Product Notes		
<ul style="list-style-type: none"> • Contact Intralox for precise belt measurements and stock status before designing equipment or ordering a belt. • Tracking tabs provide lateral tracking. • Smooth, closed surface with fully flush edges. • Uses headless rods. • Robust design offers excellent belt and sprocket durability, especially in tough, glass applications. • Smooth, flat top provides excellent lateral movement of containers. Ideal for container handling. • Optional tracking tabs fit into single barreled belt wearstrip with 1.75 in (44.5 mm) spacing. • One sprocket can be placed on the 3.25 in (83 mm) mold to width belt and the 4.5 in (114 mm) tabbed mold to width belt. One or two sprockets can be placed on the 4.5 in (114 mm) no tab mold to width belt. Up to three sprockets can be placed on the 6.0 in (152 mm) and the 7.5 in (191 mm) mold to width belt. • Most Series 1400 sprockets use the split design so shafts do not have to be removed for retrofits and changeovers. The Series 1400 sprockets are all plastic. • The Series 1400 split sprockets are designed with thick, "lug" style teeth for excellent durability and wear life. • Width tolerances for the Series 1400 Mold To Width belts are +0.000/-0.020 in (+0.000/-0.500 mm). • Series 1400 Mold To Width belts are boxed in 10 ft. (3.05 m) increments. • Utilizes Slidex® rod retention system. Slidex® is available in polypropylene or acetal. 		
Additional Information		
<ul style="list-style-type: none"> • See "Belt Selection Process" (page 5) • See "Standard Belt Materials" (page 9) • See "Special Application Belt Materials" (page 9) • See "Friction Factors" (page 13) 		

Series 1400 Flat Top Mold to Width

Series 1400 Flat Top 85 mm Mold to Width

Belt Data											
Belt Width		Belt Material	Standard Rod Material Ø 0.24 in (6.1 mm)	BS Belt Strength ^a		Temperature Range (continuous)		W Belt Weight			
								Tab		No Tab	
inch	mm			lb	kg	°F	°C	lb/ft	kg/m	lb/ft	kg/m
3.25	83	Acetal	Nylon	700	318	-50 to 200	-46 to 93	0.80	1.19	0.75	1.12
	85	Acetal	Nylon	700	318	-50 to 200	-46 to 93	0.80	1.19	-	-
4.5	114	Acetal	Nylon	850	386	-50 to 200	-46 to 93	1.13	1.68	1.07	1.59
6.0	152	Acetal	Nylon	1200	544	-50 to 200	-46 to 93	1.40	2.08	1.35	2.01
7.5	191	Acetal	Nylon	1550	703	-50 to 200	-46 to 93	1.75	2.60	1.71	2.54
6.0	152	Polypropylene	Nylon	850	386	34 to 220	1 to 104	0.95	1.14	0.90	1.34
4.5	114	HHR Nylon	Nylon	850	386	-50 to 310	-46 to 154	0.95	1.41	1.07	1.59
6.0	152	HHR Nylon	Nylon	1200	544	-50 to 310	-46 to 154	1.18	1.76	1.35	2.01
7.5	191	HHR Nylon	Nylon	1550	703	-50 to 310	-46 to 154	1.47	2.19	1.71	2.54

a. Ratings are based on non-tabbed belts using the maximum number of sprockets.

ONEPIECE™ Live Transfer Flat Top		
	in	mm
Pitch	1.00	25.4
Molded Width	6	152
Width Increments	-	-
Open Area	0%	
Hinge Style	Closed	
Drive Method	Center/hinge-driven	
Product Notes		
<ul style="list-style-type: none"> • Contact Intralox for precise belt measurements and stock status before designing equipment or ordering a belt. • Transfer edge is an integral part of this belt, designed for smooth, self-clearing, right angle transfers onto takeaway belts. • Uses headless rods. • Smooth, flat top surface with fully flush edges provides excellent lateral movement of containers, especially PET, and glass. • Built with nylon rods for superior wear resistance. Utilizes Slidex® rod retention system. Slidex is available in polypropylene or acetal. • Robust design offers excellent belt and sprocket durability, especially in tough, glass applications. • Molded with robust tracking tabs to support belt in heavy, side-loading applications. • When product is moving from the transfer belt to a takeaway belt, the top of the transfer belt should be no more than 0.06 in (1.5 mm) above the top of the takeaway belt. When product is moving from the infeed belt onto the transfer belt, the top of the belts should be level. • You may need to include a fixed frame support member beneath the ONEPIECE™ Live Transfer belt prior to the actual transfer. This ensures that the belt does not snag when it intersects with the takeaway belt. See "Fig. 3-31 PARABOLIC GUIDE RAIL CONTOURS WITH 6.0 in. (152 mm) ONEPIECE™ LIVE TRANSFER BELT" (page 442) • Most Series 1400 sprockets use the split design so shafts do not have to be removed for retrofits and changeovers. The Series 1400 sprockets are all plastic. • The Series 1400 split sprockets are designed with thick, "lug" style teeth for excellent durability and wear life. • Series 1400 Live Transfer belts are boxed in 10 ft. (3.05 m) increments. 		
Additional Information		
<ul style="list-style-type: none"> • See "Belt Selection Process" (page 5) • See "Standard Belt Materials" (page 9) • See "Special Application Belt Materials" (page 9) • See "Friction Factors" (page 13) • See "90° Container Transfers" (page 441) 		

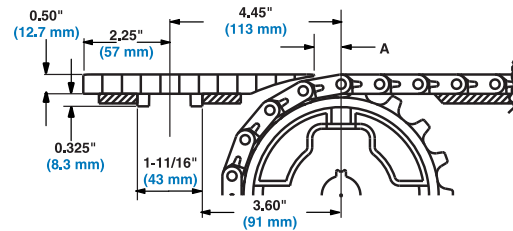
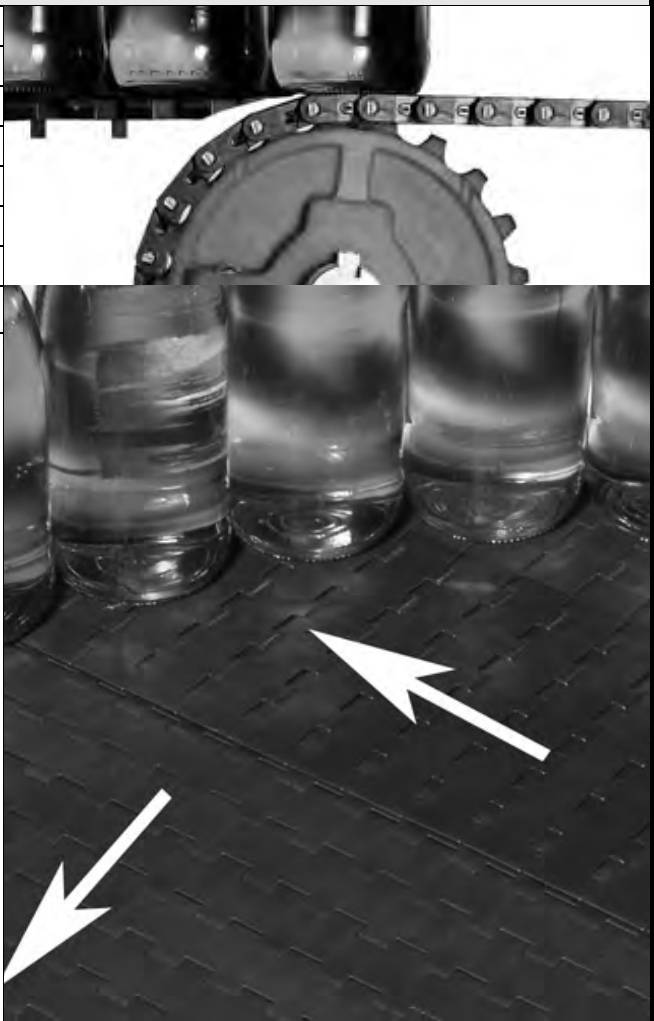

Belt Data							
Belt Material	Standard Rod Material Ø 0.24 in (6.1 mm)	BS Belt Strength		Temperature Range (continuous)		W Belt Weight	
		lb	kg	°F	°C	lb/ft	kg/m
Acetal	Nylon	850	386	-50 to 200	-46 to 93	1.25	1.86

6" Flat Top Mold to Width Self-Clearing Edge

	in	mm
Pitch	1.00	25.4
Minimum Width	6	152
Width Increments	-	-
Opening Sizes (approx.)	-	-
Open Area	0%	
Hinge Style	Closed	
Drive Method	Center/Hinge-Driven	

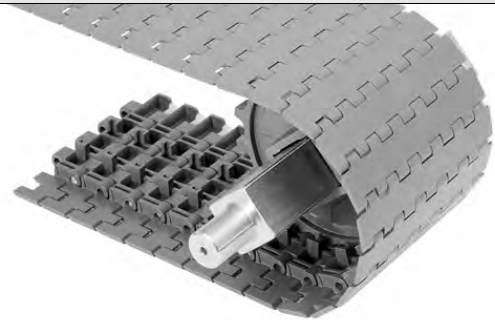

Product Notes

- **Contact Intralox for precise belt measurements and stock status before designing equipment or ordering a belt.**
- Fully flush edges.
- Uses headed rods.
- Robust design offers excellent belt and sprocket durability, especially in tough, material handling applications.
- Most Series 1400 sprockets use the split design so shafts do not have to be removed for retrofits and changeovers. All Series 1400 sprockets are plastic.
- 100% self-clearing transfers of all container types, including energy drink cans, when used in conjunction with finger transfer plate.
- Belt is bidirectional. It can perform left- and right-hand transfers.

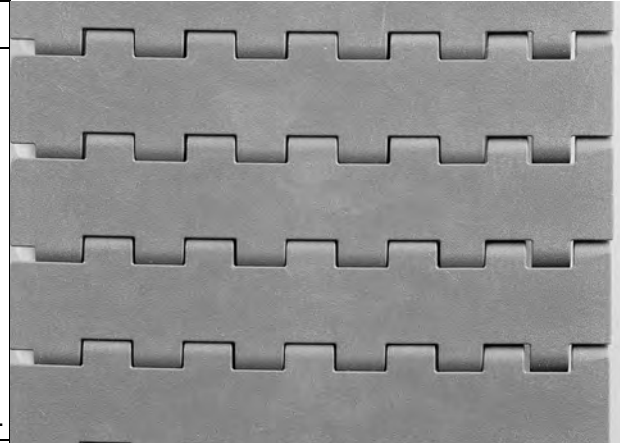

Additional Information

- See "Belt Selection Process" (page 5)
- See "Standard Belt Materials" (page 9)
- See "Special Application Belt Materials" (page 9)
- See "Friction Factors" (page 13)

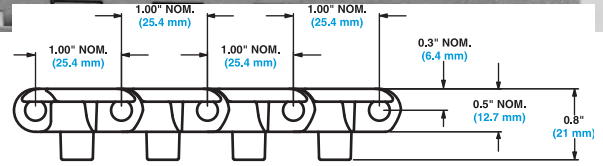

Belt Data

Belt Material	Standard Rod Material Ø 0.24 in (6.1 mm)	BS Belt Strength		Temperature Range (continuous)		W Belt Weight	
		lb	kg	°F	°C	lb/ft	kg/m
Acetal	Nylon	1000	454	-50 to 200	-46 to 93	1.08	1.61

ONEPIECE™ 9.3 in (236 mm) Live Transfer Flat Top

	in	mm
Pitch	1.00	25.4
Molded Width	9.3	236
Width Increments	-	-
Open Area	0%	
Hinge Style	Closed	
Drive Method	Center/Hinge-driven	

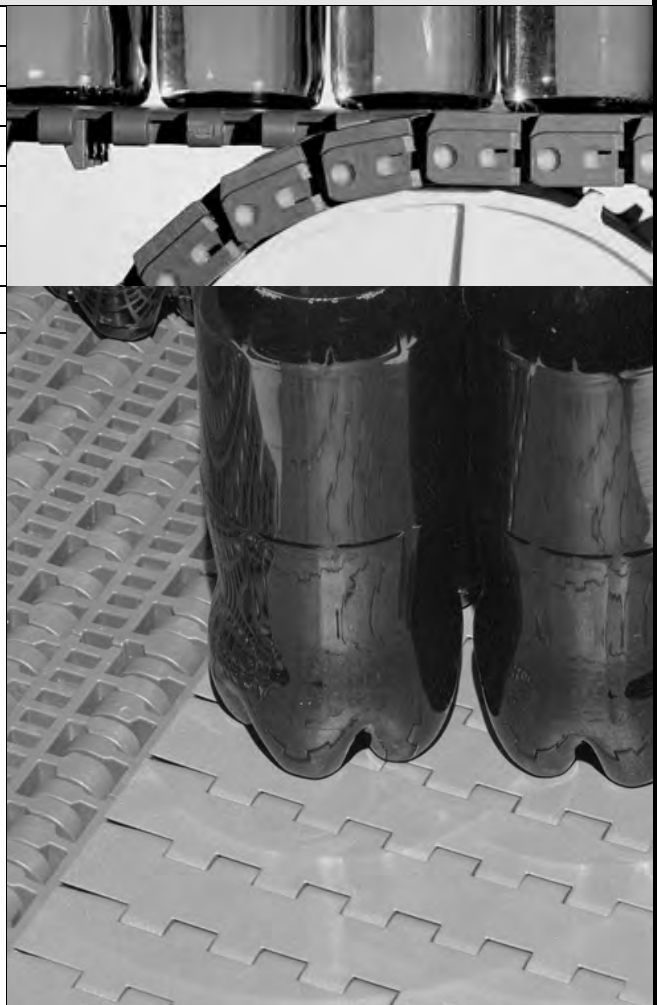

Product Notes

- **Contact Intralox for precise belt measurements and stock status before designing equipment or ordering a belt.**
- Transfer edge is an integral part of this belt, designed for smooth, self-clearing, right angle transfers onto takeaway belts.
- Smooth, flat top surface with fully flush edges provides excellent lateral movement of containers, especially PET and glass.
- Uses headless rods.
- Built with nylon rods for superior wear resistance. Uses Slidelox® rod retention system. Slidelox® is available in polypropylene or acetal.
- Robust design offers excellent belt and sprocket durability, especially in tough, glass applications.
- Molded with robust tracking tabs to support belt in heavy, side-loading applications. Tab height is 0.35 in (8.9 mm). Tab spacing is 1 11/16 in (43 mm).
- When product is moving from the transfer belt to a takeaway belt, the top of the transfer belt should be no more than 0.06 in (1.5 mm) above the top of the takeaway belt. When product is moving from the infeed belt onto the transfer belt, the top of the belts should be level.
- You may need to include a fixed frame support member beneath the **ONEPIECE™ Live Transfer** belt prior to the actual transfer. This ensures that the belt does not snag when it intersects with the takeaway belt. See "Fig. 3-31 PARABOLIC GUIDE RAIL CONTOURS WITH 6.0 in. (152 mm) **ONEPIECE™ LIVE TRANSFER BELT**" (page 442).
- Most Series 1400 sprockets use the split design so shafts do not have to be removed for retrofits and changeovers. The Series 1400 sprockets are all plastic.
- The Series 1400 split sprockets are designed with thick, "lug" style teeth for excellent durability and wear life.
- Series 1400 Live Transfer belts are boxed in 10 ft. (3.05 m) increments.

Additional Information

- See "Belt Selection Process" (page 5)
- See "Standard Belt Materials" (page 9)
- See "Special Application Belt Materials" (page 9)
- See "Friction Factors" (page 13)
- See "90° Container Transfers" (page 441)

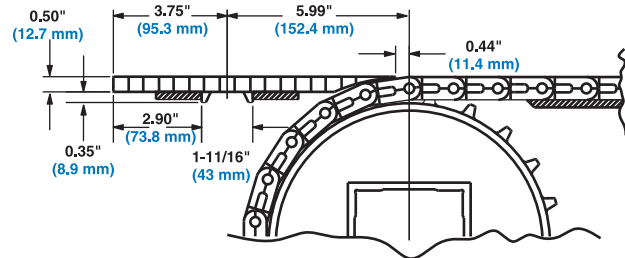

Belt Data

Belt Material	Standard Rod Material Ø 0.24 in (6.1 mm)	BS		Temperature Range (continuous)		W	
		Belt Strength		°F	°C	Belt Weight	
		lb	kg			lb/ft	kg/m
Acetal	Nylon	1550	703	-50 to 200	-46 to 93	1.86	2.77

Flush Grid

	in	mm
Pitch	1.0	25.4
Minimum Width	9	229
Width Increments	1.0	25.4
Opening Size (approx.)	0.17 x 0.30	4.2 x 7.6
Open Area	21%	
Hinge Style	Closed	
Drive Method	Center/Hinge-driven	



Product Notes

- **Contact Intralox for precise belt measurements and stock status before designing equipment or ordering a belt.**
- Uses headless rods.
- Uses Slidelox® rod retention system. Slidelox is available in polypropylene or acetal.
- Polypropylene belts are grey with blue PP Slidelox. Acetal belts are grey with yellow AC Slidelox.
- Installation is the same as current Series 1400 belts with the addition of a locked sprocket location chart and preferred run direction.
- Minimum sprocket spacing is 3 inches (76.2 mm) and is recommended for an adjusted belt pull greater than 900 lb/ft (1339 kg/m). Maximum recommended sprocket spacing is 6 inches (152.4 mm).
- Fully flush edges with Slidelox closures.

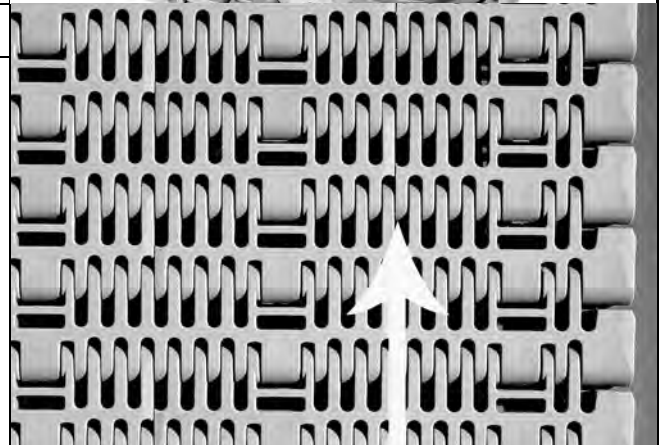

Arrow indicates run direction

Additional Information

- See "Belt Selection Process" (page 5)
- See "Standard Belt Materials" (page 9)
- See "Special Application Belt Materials" (page 9)
- See "Friction Factors" (page 13)

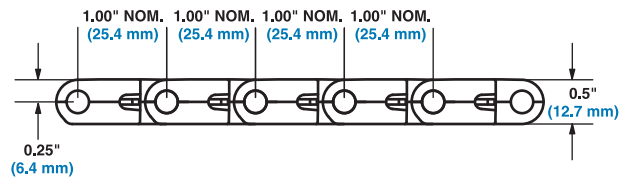

Belt Data							
Belt Material	Standard Rod Material Ø 0.24 in (6.1 mm)	BS Belt Strength ^a		Temperature Range (continuous)		W Belt Weight	
		lb/ft	kg/m	°F	°C	lb/ft ²	kg/m ²
Polypropylene	Polypropylene	1800	2679	34 to 220	1 to 104	1.61	7.86
Polypropylene	Nylon	1800	2679	34 to 220	1 to 104	1.66	8.10
Acetal	Nylon	2500	3720	-50 to 200	-46 to 93	2.52	12.30

a. Belt strength is divided by 2 when using 6 inch sprocket spacing; full strength when using 3 inch sprocket spacing.

Intralox® Flat Friction Top		
	in	mm
Pitch	1.00	25.4
Minimum Width	5	127
Width Increments	1.00	25.4
Hinge Style	Closed	
Drive Method	Center/Hinge-driven	
Product Notes		
<ul style="list-style-type: none"> Contact Intralox for precise belt measurements and stock status before designing equipment or ordering a belt. Fully flush edges with Slidelox® rod retention feature. Slidelox® is available in polypropylene or acetal. Robust design offers excellent belt and sprocket durability, especially in tough, material handling applications. Uses headless rods. Standard indents for friction top surface are 2.0 in (50.8 mm) and 0.22 in (5.6 mm). Most Series 1400 sprockets use the split design so shafts do not have to be removed for retrofits and changeovers. Friction top available in grey PP with grey rubber, grey PP with black rubber, white PP with white rubber, and black PE with black rubber. If a center-drive setup is used, it may be necessary to place collars to laterally retain the belt at the backbend roller before the drive. Temperature, environmental conditions, and product characteristics affect the effective maximum degree of incline. Take these items into consideration when designing conveyor systems utilizing these belts. 		
Additional Information		
<ul style="list-style-type: none"> See "Belt Selection Process" (page 5) See "Standard Belt Materials" (page 9) See "Special Application Belt Materials" (page 9) See "Friction Factors" (page 13) 		

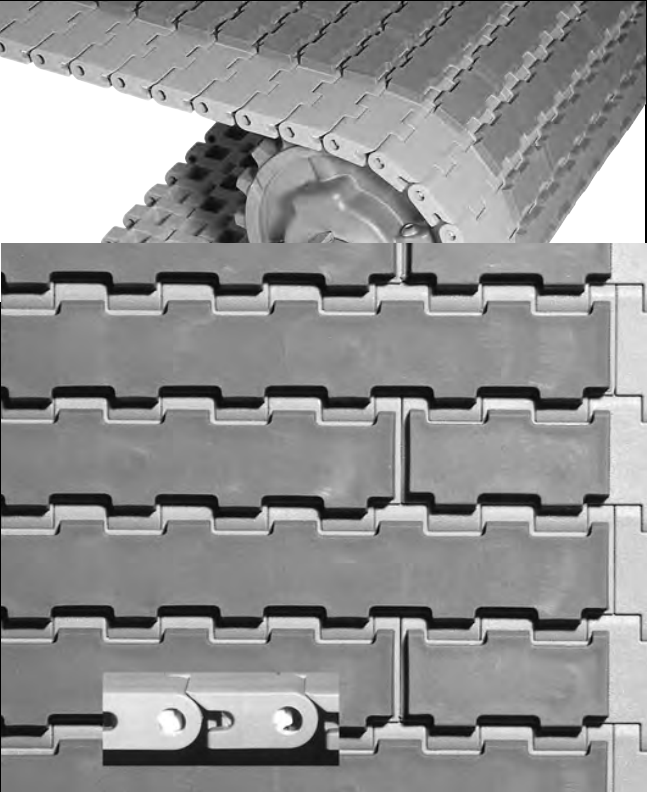

Inset: SLIDELOX® Rod Retention Feature

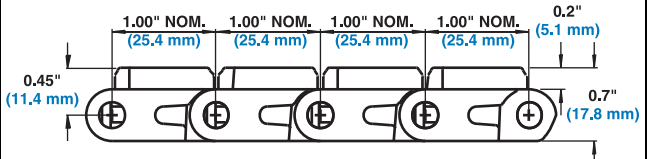

Belt Data													
Base Belt Material	Base/Friction Color	Standard Rod Material Ø 0.24 in (6.1 mm)	BS		Belt Strength		Temperature Range (continuous)		W		Friction Top Hardness	Agency Acceptability	
			lb/ft	kg/m	°F	°C	lb/ft²	kg/m²	FDA (USA)	EU MC ^b			
Polypropylene	Grey/Grey	Nylon	1800	2678	34 to 150	1 to 66	2.62	12.79	64 Shore A				
Polypropylene	Grey/Black	Nylon	1800	2678	34 to 150	1 to 66	2.62	12.79	55 Shore A	a			
Polypropylene	White/White	Nylon	1800	2678	34 to 150	1 to 66	2.62	12.79	55 Shore A	a		c	
Polyethylene	Black/Black	Nylon	1000	1488	-50 to 120	-46 to 49	2.70	13.18	-	a			

• - Fully compliant

a - FDA Compliant with Restriction: Do not use in direct contact with fatty foods.

b - European Migration Certificate providing approval for food contact according to EU Regulation 10/2011.

c - EU compliant with Restriction: Do not use in direct contact with fatty foods.

Square Friction Top

	in	mm
Pitch	1.00	25.4
Minimum Width	6	152
Width Increments	1.00	25.4
Hinge Style	Closed	
Drive Method	Center/hinge-driven	

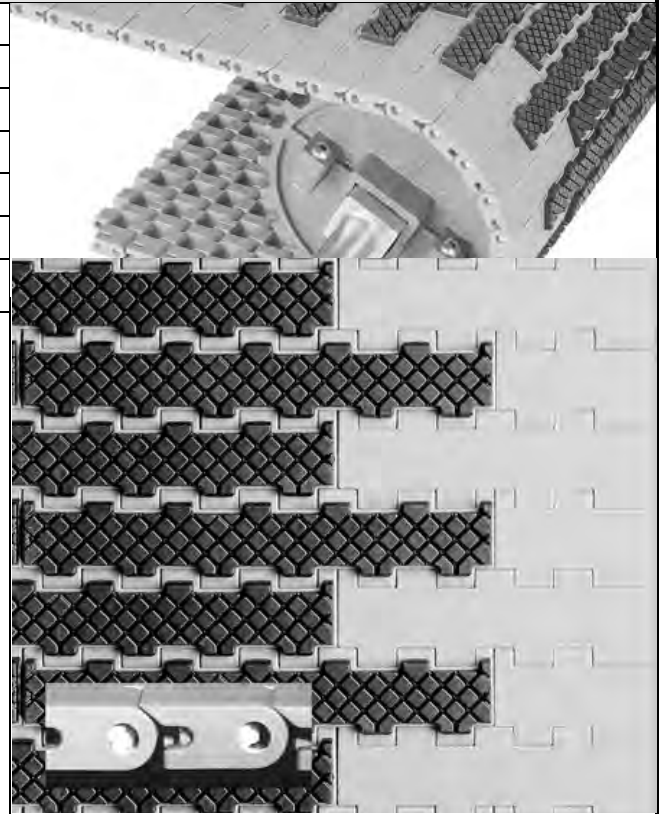

Product Notes

- **Contact Intralox for precise belt measurements and stock status before designing equipment or ordering a belt.**
- Fully flush edges with Slidelox® rod retention feature. Slidelox is available in polypropylene or acetal.
- Uses headless rods.
- Robust design offers excellent belt and sprocket durability, especially in tough, material handling applications.
- Most Series 1400 sprockets use the split design so shafts do not have to be removed for retrofits and changeovers. The Series 1400 sprockets are all plastic.
- Friction top available in grey PP with black rubber and black PE with black rubber.
- Minimum nominal alternating edge indents of 2 in (51 mm) and 3 in (76 mm).
- If a center-drive setup is used, it may be necessary to place collars to laterally retain the belt at the backbend roller before the drive.
- Temperature, environmental conditions, and product characteristics affect the effective maximum degree of incline. Take these items into consideration when designing conveyor systems utilizing these belts.

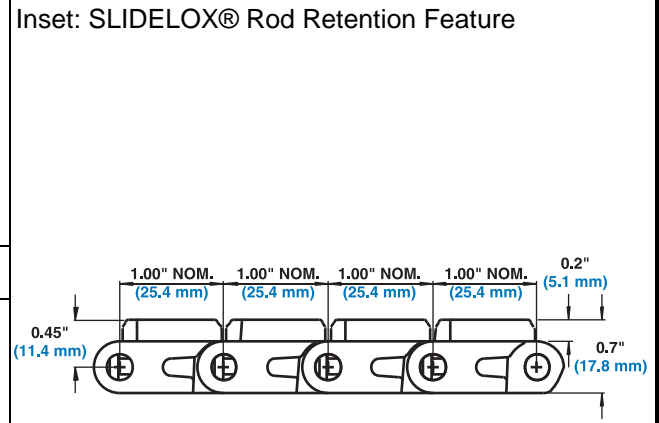

Additional Information

- See “Belt Selection Process” (page 5)
- See “Standard Belt Materials” (page 9)
- See “Special Application Belt Materials” (page 9)
- See “Friction Factors” (page 13)

Belt Data

Base Belt Material	Base/Friction Color	Standard Rod Material Ø 0.24 in (6.1 mm)	BS		Temperature Range (continuous)		W		Friction Top Hardness	Agency Acceptability	
			Belt Strength		°F	°C	Belt Weight			FDA (USA)	EU MC ^b
			lb/ft	kg/m			lb/ft ²	kg/m ²			
Polypropylene	Grey/Black	Nylon	1800	2678	34 to 150	1 to 66	2.60	12.69	50 Shore A	a	
Polyethylene	Black/Black	Nylon	1000	1488	-50 to 120	-46 to 49	2.68	13.08	-	a	

• - Fully compliant

a - FDA Compliant with Restriction: Do not use in direct contact with fatty foods.

b - European Migration Certificate providing approval for food contact according to EU Regulation 10/2011.

c - EU compliant with Restriction: Do not use in direct contact with fatty foods.

3.25 in Mold to Width Flat Friction Top with Tabs

	in	mm
Pitch	1.00	25.4
Molded Width	3.25	83
Opening Sizes (approx.)	-	-
Open Area	0%	
Hinge Style	Closed	
Drive Method	Center/Hinge-Driven	



Product Notes

- **Contact Intralox for precise belt measurements and stock status before designing equipment or ordering a belt.**
- Not recommended for back-up conditions. If friction values between product and belt are required, contact Intralox Sales Engineering.
- Tracking tabs provide lateral tracking.
- Fully flush edges with Slidelox rod retention feature.
- Uses headless rods.
- Robust design offers excellent belt and sprocket durability, especially in tough, material handling applications.
- Available in blue acetal with black rubber.
- Indent for Friction Top surface is 0.5 in (12.7 mm).
- One sprocket can be placed on the 3.25 in (83 mm) Mold To Width tabbed belt.
- Width tolerances for the Series 1400 Mold to Width belts are +0.000/-0.020 in (+0.000/-0.500 mm).
- Most Series 1400 sprockets use the split design so shafts do not have to be removed for retrofits and changeovers. The Series 1400 sprockets are all plastic.
- Series 1400 Mold to Width belts are boxed in 10 ft. (3.05 m) increments.
- Temperature, environmental conditions, and product characteristics affect the effective maximum degree of incline. Take these items into consideration when designing conveyor systems utilizing these belts.



Additional Information

- See "Belt Selection Process" (page 5)
- See "Standard Belt Materials" (page 9)
- See "Special Application Belt Materials" (page 9)
- See "Friction Factors" (page 13)

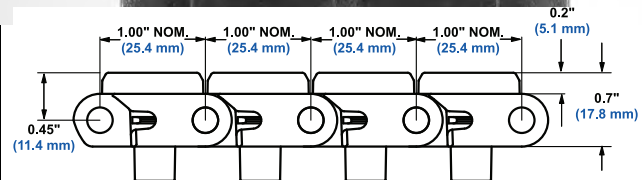

Belt Data

Base Belt Material	Base/Friction Color	Standard Rod Material Ø 0.24 in (6.1 mm)	BS Belt Strength		Temperature Range (continuous)		W Belt Weight		Friction Top Hardness	Agency Acceptability	
			lb	kg	°F	°C	lb/ft	kg/m		FDA (USA)	EU MC ^b
Acetal	Blue/Black	Nylon	700	318	-10 to 130	-23 to 54	0.94	1.40	54 Shore A		

• - Fully compliant

a - FDA Compliant with Restriction: Do not use in direct contact with fatty foods.

b - European Migration Certificate providing approval for food contact according to EU Regulation 10/2011.

Mold to Width Square Friction Top

	in	mm
Pitch	1.00	25.4
Molded Width	6	152
Open Area	0%	
Hinge Style	Closed	
Drive Method	Center/hinge-driven	

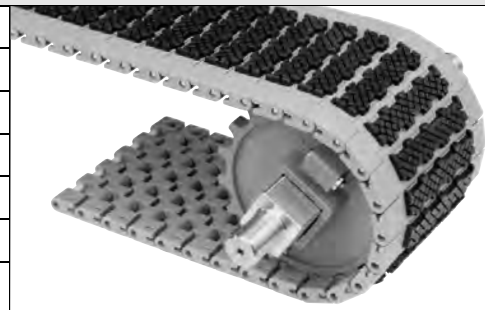

Product Notes

- **Contact Intralox for precise belt measurements and stock status before designing equipment or ordering a belt.**
- Fully flush edges with Slidelox® rod retention feature. Slidelox is available in polypropylene or acetal.
- Uses headless rods.
- Robust design offers excellent belt and sprocket durability, especially in tough, material handling applications.
- Most Series 1400 sprockets use the split design so shafts do not have to be removed for retrofits and changeovers. The Series 1400 sprockets are all plastic.
- Available in grey PP with black rubber.
- Rubber indent is 1.0 in (25.4 mm).
- If a center-drive setup is used, it may be necessary to place collars to laterally retain the belt at the backbend roller before the drive.
- Temperature, environmental conditions, and product characteristics affect the effective maximum degree of incline. Take these items into consideration when designing conveyor systems utilizing these belts.
- Up to three sprockets can be placed on the 6.0 in (152 mm) mold to width belt.
- Width tolerances for the Series 1400 Mold To Width belts are +0.000/-0.020 in (+0.000/-0.500 mm).
- Series 1400 Mold To Width belts are boxed in 10 ft. (3.05 m) increments.

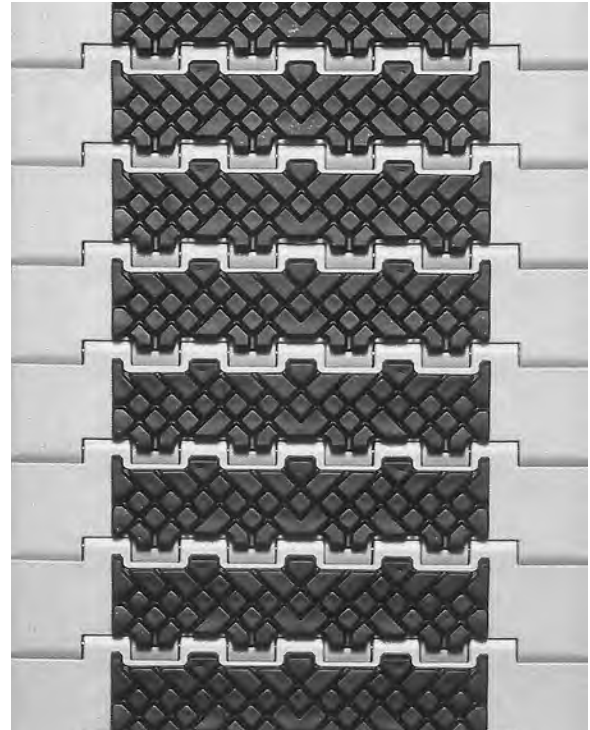

Additional Information

- See "Belt Selection Process" (page 5)
- See "Standard Belt Materials" (page 9)
- See "Special Application Belt Materials" (page 9)
- See "Friction Factors" (page 13)

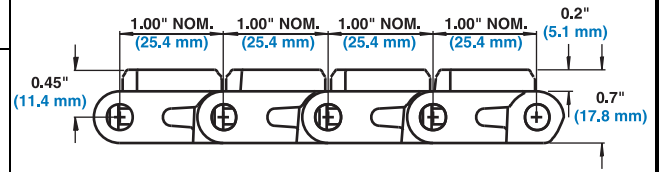

Belt Data

Base Belt Material	Base/Friction Color	Standard Rod Material Ø 0.24 in (6.1 mm)	BS Belt Strength		Temperature Range (continuous)		W Belt Weight		Friction Top Hardness	Agency Acceptability	
			lb	kg	°F	°C	lb/ft	kg/m		FDA (USA)	EU MC ^b
Polypropylene	Grey/Black	Nylon	800	386	34 to 150	1 to 66	1.15	1.71	50 Shore A	a	

- - Fully compliant
- a - FDA Compliant with Restriction: Do not use in direct contact with fatty foods.
- b - European Migration Certificate providing approval for food contact according to EU Regulation 10/2011.
- c - EU compliant with Restriction: Do not use in direct contact with fatty foods.

Oval Friction Top		
	in	mm
Pitch	1.00	25.4
Minimum Width	5	127
Width Increments	1.00	25.4
Open Area	0%	
Hinge Style	Closed	
Drive Method	Center/hinge-driven	

Product Notes

- Contact Intralox for precise belt measurements and stock status before designing equipment or ordering a belt.
- Fully flush edges with Slidelox® rod retention feature. Slidelox is available in polypropylene or acetal.
- Uses headless rods.
- Robust design offers excellent belt and sprocket durability, especially in tough, material handling applications.
- Available in grey PP with black rubber.
- Most Series 1400 sprockets use the split design so shafts do not have to be removed for retrofits and changeovers. The Series 1400 sprockets are all plastic.
- Rubber indent is 1.0 in (25.4 mm).
- If a center-drive setup is used, it may be necessary to place collars to laterally retain the belt at the backbend roller before the drive.
- Temperature, environmental conditions, and product characteristics affect the effective maximum degree of incline. Take these items into consideration when designing conveyor systems utilizing these belts.

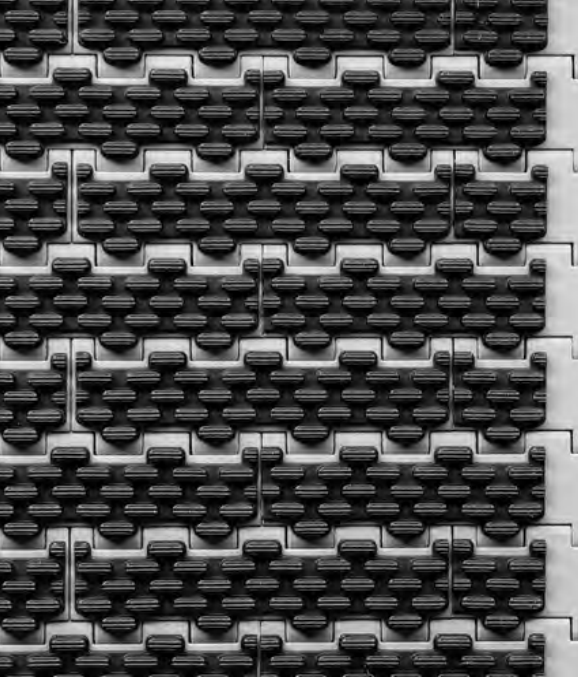
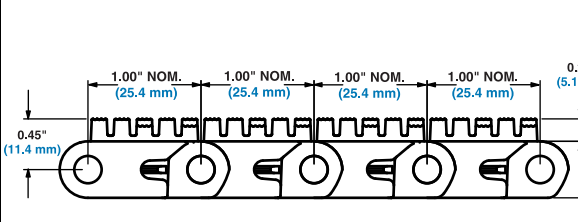
Additional Information

- See "Belt Selection Process" (page 5)
- See "Standard Belt Materials" (page 9)
- See "Special Application Belt Materials" (page 9)
- See "Friction Factors" (page 13)

Belt Data													
Base Belt Material	Base/Friction Color	Standard Rod Material Ø 0.24 in (6.1 mm)	BS	Belt Strength		Temperature Range (continuous)		W	Belt Weight		Friction Top Hardness	Agency Acceptability	
				lb/ft	kg/m	°F	°C		lb/ft ²	kg/m ²		FDA (USA)	EU MC ^b
Polypropylene	Grey/Black	Nylon		1800	2678	34 to 150	1 to 66		2.29	11.18	55 Shore A	a	

• - Fully compliant

a - FDA Compliant with Restriction: Do not use in direct contact with fatty foods.

b - European Migration Certificate providing approval for food contact according to EU Regulation 10/2011.

c - EU compliant with Restriction: Do not use in direct contact with fatty foods.

Mold to Width Oval Friction Top

	in	mm
Pitch	1.00	25.4
Molded Width	6	152
Open Area	0%	
Hinge Style	Closed	
Drive Method	Center/hinge-driven	

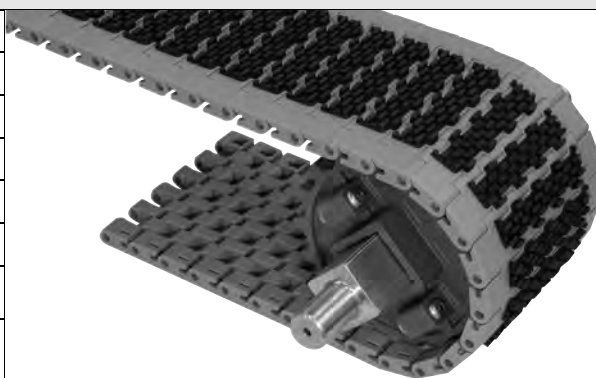

Product Notes

- **Contact Intralox for precise belt measurements and stock status before designing equipment or ordering a belt.**
- Fully flush edges with Slidelox® rod retention feature. Slidelox is available in polypropylene or acetal.
- Uses headless rods.
- Robust design offers excellent belt and sprocket durability, especially in tough, material handling applications.
- Most Series 1400 sprockets use the split design so shafts do not have to be removed for retrofits and changeovers. The Series 1400 sprockets are all plastic.
- Available in grey PP with black rubber.
- Rubber indent is 1.0 in (25.4 mm).
- If a center-drive setup is used, it may be necessary to place collars to laterally retain the belt at the backbend roller before the drive.
- Temperature, environmental conditions, and product characteristics affect the effective maximum degree of incline. Take these items into consideration when designing conveyor systems utilizing these belts.
- Up to three sprockets can be placed on the 6.0 in (152 mm) mold to width belt.
- Width tolerances for the Series 1400 Mold To Width belts are +0.000/-0.020 in (+0.000/-0.500 mm).
- Series 1400 Mold To Width belts are boxed in 10 ft. (3.05 m) increments.

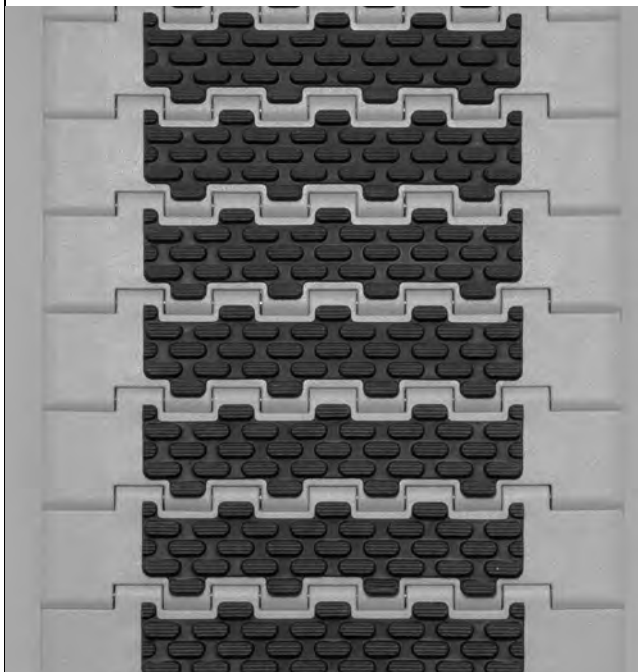

Additional Information

- See "Belt Selection Process" (page 5)
- See "Standard Belt Materials" (page 9)
- See "Special Application Belt Materials" (page 9)
- See "Friction Factors" (page 13)

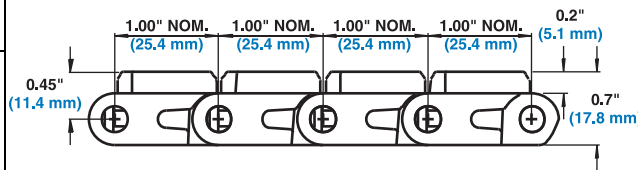

Belt Data

Base Belt Material	Base/Friction Color	Standard Rod Material Ø 0.24 in (6.1 mm)	BS		Temperature Range (continuous)		W		Friction Top Hardness	Agency Acceptability	
			Belt Strength		°F	°C	Belt Weight			FDA (USA)	EU MC ^b
Polypropylene	Grey/Black	Nylon	800	386	34 to 150	1 to 66	1.15	1.71	55 Shore A	a	

• - Fully compliant

a - FDA Compliant with Restriction: Do not use in direct contact with fatty foods.

b - European Migration Certificate providing approval for food contact according to EU Regulation 10/2011.

Roller Top™		
	in	mm
Pitch	1.00	25.4
Minimum Width	5	127
Width Increments	1.00	25.4
Roller Diameter	0.70	17.8
Roller Length	0.83	21.0
Open Area	0%	
Hinge Style	Closed	
Drive Method	Center/hinge-driven	

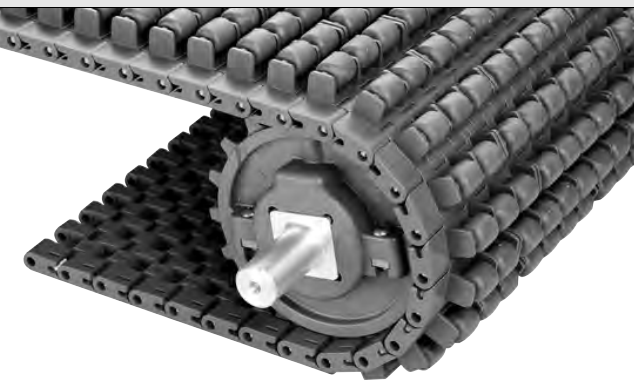

Product Notes

- Contact Intralox for precise belt measurements and stock status before designing equipment or ordering a belt.
- Allows low back pressure accumulation for gentle product handling.
- 144 rollers per square foot of belt provide greater product-to-roller contact.
- Standard roller indent is 0.75 in (19 mm)
- 1 in (25.4 mm) roller spacing.
- Available in white and grey acetal.
- Uses headless rods.
- Stainless steel roller axle pins for durability.
- Robust design offers excellent belt and sprocket durability.
- Slidelox® flush edges. Slidelox is available in polypropylene or acetal.
- Back-up load is 5-10% of product weight.

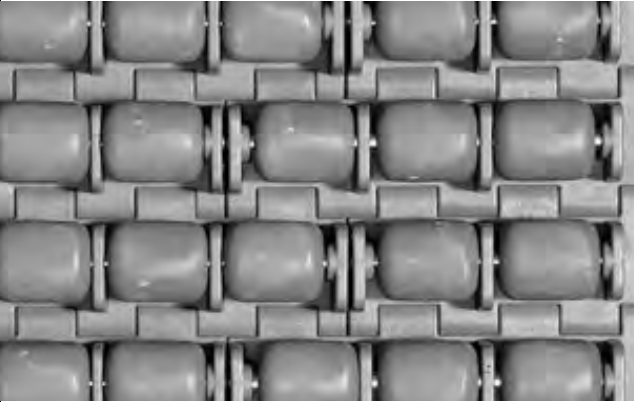

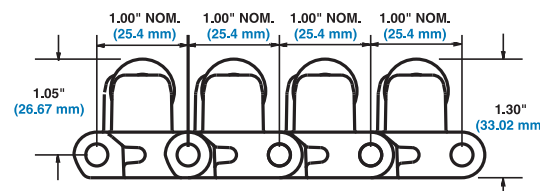

Additional Information

- See "Belt Selection Process" (page 5)
- See "Standard Belt Materials" (page 9)
- See "Special Application Belt Materials" (page 9)
- See "Friction Factors" (page 13)

Belt Data							
Belt Material	Standard Rod Material Ø 0.24 in (6.1 mm)	BS Belt Strength		Temperature Range (continuous)		W Belt Weight	
		lb/ft	kg/m	°F	°C	lb/ft²	kg/m²
Acetal	Nylon	2500	3720	-50 to 200	-46 to 93	5.83	28.47

Non Skid

	in	mm
Pitch	1.00	25.4
Minimum Width	9	229
Width Increments	1.00	25.4
Opening Size (approx.)	-	-
Open Area	0%	
Hinge Style	Closed	
Drive Method	Center/hinge-driven	

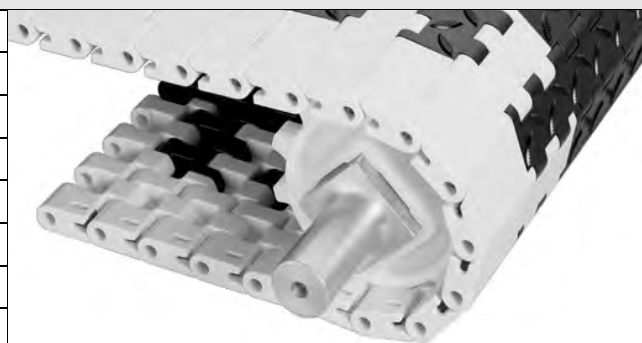

Product Notes

- **Contact Intralox for precise belt measurements and stock status before designing equipment or ordering a belt.**
- Robust design offers excellent belt and sprocket durability.
- Slidelox® rod retention system. Slidelox is available in polypropylene or acetal.
- Uses headless rods.
- 1.00 (25.4 mm) pitch accommodates small drive sprockets for low-profile people carriers.
- Diamond tread pattern provides a non-skid walking surface to increase safety.
- Staggered yellow edges make it easy to distinguish the moving belt from the stationary floor.
- Edges have Flat Top surface (no treads).
- Minimum nominal alternating edge indents of 2 in (51 mm) and 3 in (76 mm).

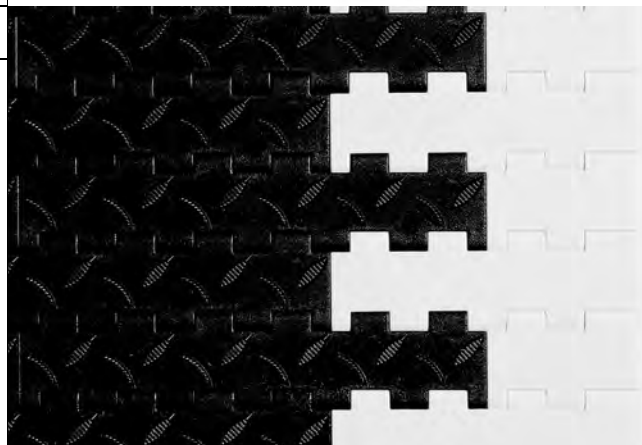

Additional Information

- See "Belt Selection Process" (page 5)
- See "Standard Belt Materials" (page 9)
- See "Special Application Belt Materials" (page 9)
- See "Friction Factors" (page 13)

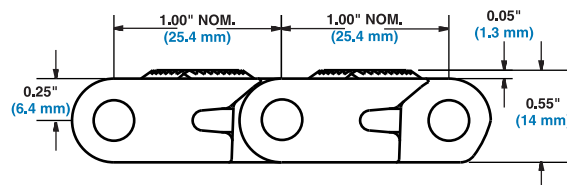

Belt Data

Belt Material	Standard Rod Material Ø 0.24 in (6.1 mm)	BS Belt Strength		Temperature Range (continuous)		W Belt Weight	
		lb/ft	kg/m	°F	°C	lb/ft ²	kg/m ²
HSEC Acetal	Nylon	1875	2790	-50 to 200	-46 to 93	2.78	13.57
Polypropylene	Nylon	1800	2678	34 to 220	1 to 104	2.32	11.33

Embedded Diamond Top		
	in	mm
Pitch	1.00	25.4
Minimum Width	12.0	304.8
Opening Sizes (approx.)	-	-
Open Area	0%	
Hinge Style	Closed	
Drive Method	Center/Hinge-Driven	
Product Notes		
<ul style="list-style-type: none"> • Contact Intralox for precise belt measurements and stock status before designing equipment or ordering a belt. • Minimum nominal alternating edge indents of 3 in (76 mm) and 4 in (102 mm). • Smooth, closed surface with fully flush edges. • Uses headless rods. • Robust design offers excellent belt and sprocket durability. • Most Series 1400 sprockets use the split design so shafts do not have to be removed for retrofits and changeovers. • Series 1400 split sprockets are designed with thick, "lug" style teeth for excellent durability and wear life. • Utilizes Slidelox® rod retention system. 		
Additional Information		
<ul style="list-style-type: none"> • See "Belt Selection Process" (page 5) • See "Standard Belt Materials" (page 9) • See "Special Application Belt Materials" (page 9) • See "Friction Factors" (page 13) 		

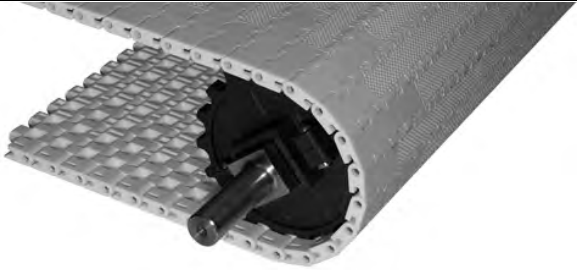
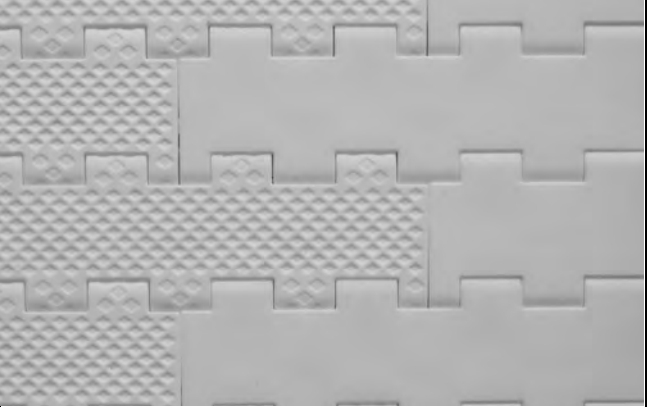
Belt Data							
Belt Material	Standard Rod Material Ø 0.24 in (6.1 mm)	BS	Belt Strength	Temperature Range (continuous)		W	Belt Weight
		lb/ft	kg/m	°F	°C	lb/ft ²	kg/m ²
Polypropylene	Nylon	1800	2678	34 to 220	1 to 104	1.70	8.30

Flat Top Easy Release PLUS

	in	mm
Pitch	1.00	25.4
Minimum Width	5	127
Width Increments	1.00	25.4
Opening Size (approximate)	-	-
Open Area	0%	
Hinge Style	Closed	
Drive Method	Center/Hinge-driven	

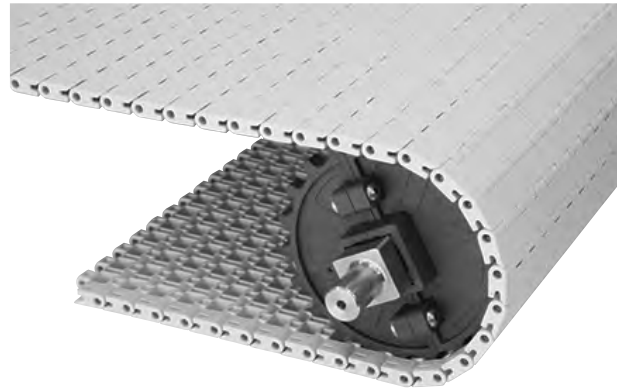

Product Notes

- **Contact Intralox for precise belt measurements and stock status before designing equipment or ordering a belt.**
- Easy Release PLUS material resists rubber adhesion and exhibits minimal dimensional expansion when exposed to oil and heat.
- Features a smooth, closed surface with fully flush edges.
- Uses headless rods.
- Robust design provides excellent belt and sprocket durability, especially in tough material handling applications.
- Series 1400 sprockets feature thick, lug-style teeth for excellent durability and wear life.
- Series 1400 split sprockets enable easy retrofits and changeovers without shaft removal.
- Utilizes Slidelox® rod retention system. Slidelox material is polypropylene.

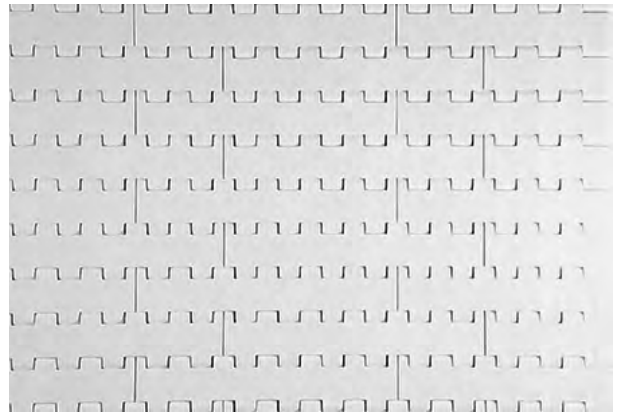

Additional Information

- See "Belt Selection Process" (page 5)
- See "Standard Belt Materials" (page 9)
- See "Special Application Belt Materials" (page 9)
- See "Friction Factors" (page 13)

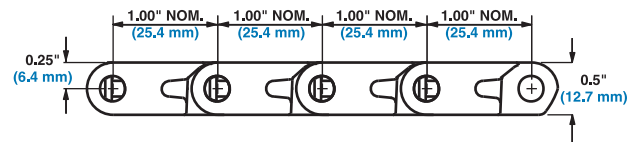

Belt Data

Belt Material	Standard Rod Material Ø 0.24 in (6.1 mm)	BS		Belt Strength		Temperature Range (continuous)		W		Belt Weight	
		lb/ft	kg/m	°F	°C	lb/ft ²	kg/m ²				
Easy Release PLUS	Orange Polypropylene (non-FDA)	1600	2380	34 to 220	1 to 104	2.00	9.78				

Flat Top Easy Release Traceable Polypropylene

	in	mm
Pitch	1.00	25.4
Minimum Width	5	127
Width Increments	1.00	25.4
Opening Size (approximate)	-	-
Open Area	0%	
Hinge Style	Closed	
Drive Method	Center/Hinge-driven	

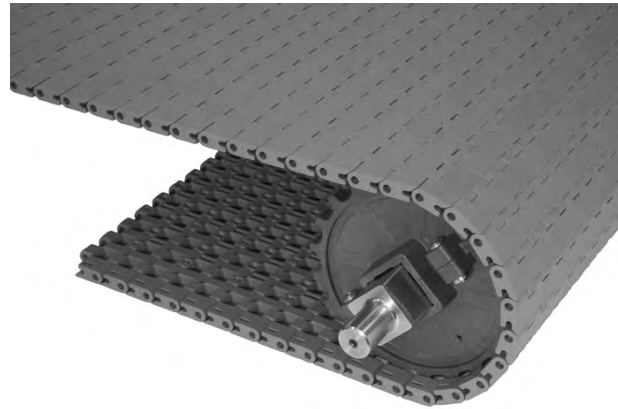

Product Notes

- **Contact Intralox for precise belt measurements and stock status before designing equipment or ordering a belt.**
- Smooth, closed surface with fully flush edges.
- Uses headless rods.
- Robust design offers excellent belt and sprocket durability, especially in tough glass applications.
- Most Series 1400 sprockets use the split design so shafts do not have to be removed for retrofits and changeovers. The Series 1400 sprockets are all plastic.
- The Series 1400 split sprockets are designed with thick, "lug" style teeth for excellent durability and wear life.
- Utilizes Slidelox® rod retention system. The Slidelox® for this product are molded with the detectable polypropylene material.

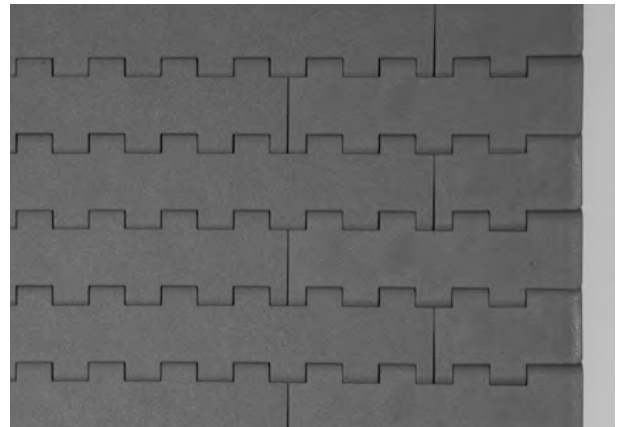

Additional Information

- See "Belt Selection Process" (page 5)
- See "Standard Belt Materials" (page 9)
- See "Special Application Belt Materials" (page 9)
- See "Friction Factors" (page 13)

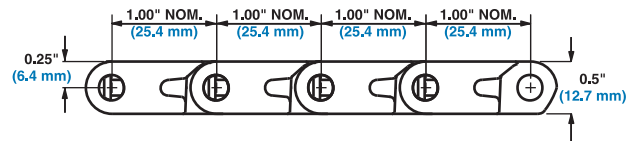

Belt Data

Belt Material	Standard Rod Material Ø 0.24 in (6.1 mm)	BS		Temperature Range (continuous)		W	
		Belt Strength		°F	°C	Belt Weight	
		lb/ft	kg/m			lb/ft ²	kg/m ²
Easy Release Traceable PP	Orange Polypropylene (non-FDA)	1200	1790	34 to 220	1 to 104	1.86	9.08

ProTrax™ with Tabs

	in	mm
Pitch	1.00	25.4
Molded Widths	4.5	114.3
Opening Size (approx.)	-	-
Open Area	0%	
Hinge Style	Closed	
Drive Method	Center/Hinge-Driven	

Product Notes

- **Contact Intralox for precise belt measurements and stock status before designing equipment or ordering a belt.**
- Powerful magnets are embedded in the belts.
- Tracking tabs prevent lateral movement. Tabs fit into a straight track style carryway with 1.75 in (44.5 mm) spacing.
- Standard configuration consists of magnetic modules and S1400 Raised Flat Top modules alternating every other row to maximize wear resistance.
- Ideal for incline, decline, vertical switch, pan indexing, and metering applications.
- This 4.5 in (114 mm) mold to width belt only needs one drive sprocket and one idle sprocket per belt strand.
- Most S1400 sprockets use the split design so shafts do not have to be removed for retrofits and changeovers. The S1400 sprockets are all plastic with stainless steel fasteners.
- The S1400 sprockets are designed with thick, “lug” style teeth for excellent durability and wear life.
- Uses Slidelox® for rod and cap retention.
- Uses headless rods.
- Both strands of the belt should be installed so that they run in the same direction.
- Belt spacing should be determined based on maximum surface area contact with the bottom surface of the conveyed product.

Additional Information

- See “Belt Selection Process” (page 5)
- See “Standard Belt Materials” (page 9)
- See “Special Application Belt Materials” (page 9)

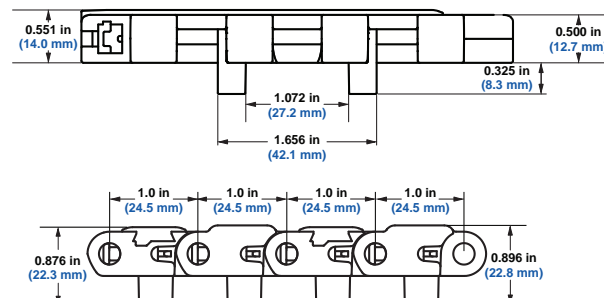
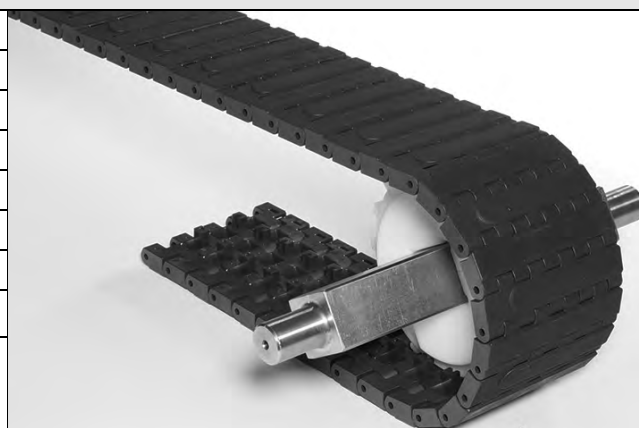

Belt Data

Belt Material	Standard Rod Material Ø 0.18 in (4.6 mm)	BS		Temperature Range (continuous)		W	
		lb	kg	°F	°C	lb/ft	kg/m
Acetal	Nylon	550	250	-50 to 200	-46 to 93	1.46	2.18
HHR Nylon	Nylon	550	250	-50 to 310	-46 to 154	1.296	1.95

Sprocket and Support Quantity Reference				
Belt Width Range ^a		Minimum Number of Sprockets Per Shaft ^b	Wearstrips	
in.	mm		Carryway	Returnway ^c
5	127	2	2	2
6	152	2	2	2
7	178	2	3	2
8	203	2	3	2
10	254	2	3	2
12	305	3	3	2
14	356	3	4	3
16	406	3	4	3
18	457	3	4	3
20	508	5	5	3
24	610	5	5	3
30	762	5	6	4
32	813	7	7	4
36	914	7	7	4
42	1067	7	8	5
48	1219	9	9	5
54	1372	9	10	6
60	1524	11	11	6
72	1829	12	13	7
84	2134	15	15	8
96	2438	17	17	9
For Other Widths, Use Odd Number of Sprockets ^d at Maximum 6 in. (152 mm) \varnothing Spacing			Maximum 6 in. (152 mm) \varnothing Spacing	Maximum 12 in. (305 mm) \varnothing Spacing

- If your belt width exceeds a number listed in the table, please refer to the sprocket and support material minimums for the next larger width range listed. Belts are available in 1.00 in. (25.4 mm) increments beginning with minimum width of 5 in. (127 mm). **If the actual width is critical, consult Customer Service.**
- These are the minimum number of sprockets. Additional sprockets may be required for heavily loaded applications.
- Caution when using Friction Top. **Contact Intralox Customer Service for friction top applications.**
- The center sprocket should be locked down. With only two sprockets, fix the sprocket on the drive journal side only. See Retainer Rings/Center Sprocket Offset chart on page 410 for lock down location. For Flush Grid, see Locked Sprocket Location chart in the Installation Instruction Guidelines or call Customer Service for lock down location.

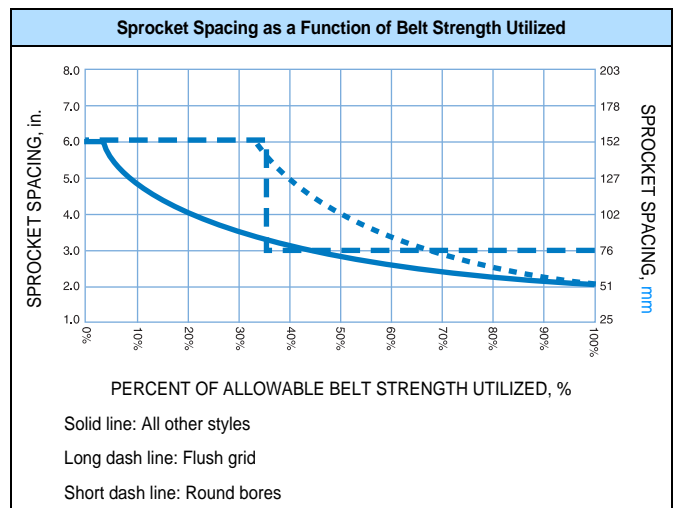
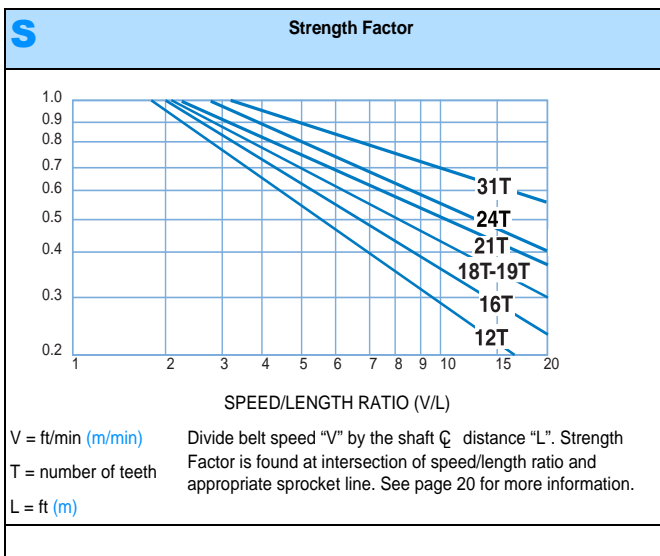

S1400 ProTrax with Tabs

Magnet Force vs. Metal Thickness

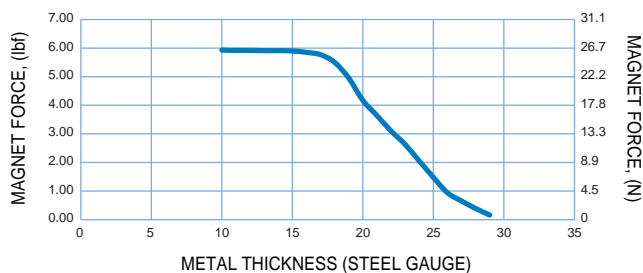

Note: Magnet force shown is typical for an aluminized steel product with a flat surface and maximum surface area contact.

Results may vary based on material and surface texture.

Plastic Sprocket^a

No. of Teeth (Chordal Action)	Nom. Pitch Dia. in	Nom. Pitch Dia. mm	Nom. Outer Dia. in	Nom. Outer Dia. mm	Nom. Hub Width in	Nom. Hub Width mm	Available Bore Sizes			
							U.S. Sizes		Metric Sizes	
							Round in	Square in	Round mm	Square mm
12 (3.41%)	3.9	99	3.9	99	1.5	38	-	1.5	-	40
15 (2.19%)	4.9	124	4.9	124	1.5	38		2.5		60
18 (1.52%)	5.7	145	5.8	148	1.5	38	2	2.5	30, 40, 50	60
24 (0.86%)	7.7	196	7.8	198	1.5	38		2.5		60

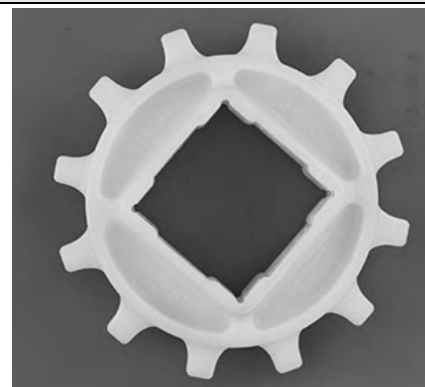

a. Contact Customer Service for lead times.

Glass Filled Nylon Split Sprocket^a

No. of Teeth (Chordal Action)	Nom. Pitch Dia. in	Nom. Pitch Dia. mm	Nom. Outer Dia. in	Nom. Outer Dia. mm	Nom. Hub Width in	Nom. Hub Width mm	Available Bore Sizes			
							U.S. Sizes		Metric Sizes	
							Round in ^b	Square in	Round mm ^b	Square mm
16 (1.92%)	5.1	130	5.2	132	2.0	51	1 to 2 in 1/16 increments	1.5	25 to 50 in 5 increments	40
18 (1.52%)	5.7	145	5.8	148	2.0	51	1 to 2 in 1/16 increments	1.5 2.5	25 to 50 in 5 increments	40 60
21 (1.12%)	6.7	170	6.8	172	2.0	51	1 to 2 in 1/16 increments ^c	1.5 2.5	25 to 50 in 5 increments	40 60



a. Contact Customer Service for lead times.

b. Imperial key sizes on round bore sprockets conform to ANSI standard B17.1-1967 (R1989) and metric key sizes conform to DIN standard 6885.

c. Tight fit round bores are available in 1-1/4, 1-3/16, 1-1/2, and 1-7/16 in.

Maximum Belt Rating for Glass Filled Nylon Round Bore Split Sprockets Based on Round Bore Size Range ^a														
No. of Teeth	Nom. Pitch Diameter		1 in - 1-3/16 in		1-1/4 in - 1-3/8 in		1-7/16 in - 1-3/4 in		1-13/16 in - 2 in		25 mm - 35 mm		40 mm - 50 mm	
	in	mm	lb/ft	kg/m	lb/ft	kg/m	lb/ft	kg/m	lb/ft	kg/m	lb/ft	kg/m	lb/ft	kg/m
16	5.1	130	1500	2232	1740	2589	2100	3125	2160	3214	1140	1697	2160	3214
18	5.7	145	1800	2679	2040	3036	2400	3572	3240	4822	1440	2143	2460	3661
21	6.7	170	1350	2009	1650	2455	2100	3125	3000	4464	1050	1563	2400	3572

a. The belt rating based on round bore sprocket size is used to determine sprocket spacing as a function of belt strength utilized. It may also be used for all other calculations. However, if the rating for the belt material and belt style is lower than the belt rating based on the round bore sprocket size, then the lower rating should be used for all calculations other than sprocket spacing.

Nylon FDA Split Sprocket ^a												
No. of Teeth (Chordal Action)	Nom. Pitch Dia. in	Nom. Pitch Dia. mm	Nom. Outer Dia. in	Nom. Outer Dia. mm	Nom. Hub Width in	Nom. Hub Width mm	Available Bore Sizes					
							U.S. Sizes		Metric Sizes			
							Round in ^b	Square in	Round mm ^b	Square mm		
12 (3.41%)	3.9	99	3.9	99	0.75	19	1.25	1.5				
16 (1.92%)	5.1	130	5.2	132	1.5	38	1.25	1.5	30		40	
18 (1.52%)	5.7	145	5.8	148	1.5	38	1.25	1.5	25 30		40	
									40			

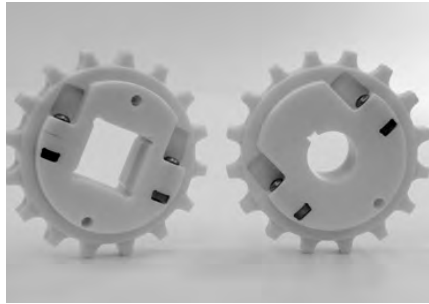

a. Contact Customer Service for lead times.
 b. Imperial key sizes on round bore sprockets conform to ANSI standard B17.1-1967 (R1989) and metric key sizes conform to DIN standard 6885.

Enduralox Polypropylene Composite Split Sprocket ^a											
No. of Teeth (Chordal Action)	Nom. Pitch Dia. in	Nom. Pitch Dia. mm	Nom. Outer Dia. in	Nom. Outer Dia. mm	Nom. Hub Width in	Nom. Hub Width mm	Available Bore Sizes				
							U.S. Sizes		Metric Sizes		
							Round in ^b	Square in	Round mm ^b	Square mm	
16 (1.92%)	5.1	130	5.2	132	2.0	51		1.5		40	
18 (1.52%)	5.7	145	5.8	148	2.0	51		1.5		40	
								2.5		60	
21 (1.12%)	6.7	170	6.8	172	2.0	51		1.5		40	
								2.5			
31 (0.51%)	9.9	251	10.1	257	2.0	51		3.5			



a. Contact Customer Service for lead times.
 b. Imperial key sizes on round bore sprockets conform to ANSI standard B17.1-1967 (R1989) and metric key sizes conform to DIN standard 6885.

Polyurethane Composite Split Sprocket ^a											
No. of Teeth (Chordal Action)	Nom. Pitch Dia. in	Nom. Pitch Dia. mm	Nom. Outer Dia. in	Nom. Outer Dia. mm	Nom. Hub Width in	Nom. Hub Width mm	Available Bore Sizes				
							U.S. Sizes		Metric Sizes		
							Round in	Square in	Round mm	Square mm	
31 (0.51%)	9.9	251	10.1	257	1.50	38		3.5			
					1.67	44		2.5 ^b			



a. Contact Customer Service for lead times.
 b. The 2.5" square bore is created by using a bore adapter in the 3.5" square bore sprocket.

S1400 Flat Top Base Flights (Streamline)

Available Flight Height		Available Materials
in	mm	
0.43	11	Easy Release Traceable Polypropylene

Note: The minimum indent is a function of belt width. Contact Intralox Customer Service for valid indent increments.

Note: Each flight rises out of the center of its supporting module, molded as an integral part. No fasteners are required.

Note: Flight is smooth (streamline) on both sides.



Self-Clearing Finger Transfer Plates^a

Available Width		Number of Fingers	Available Materials
in	mm		
6	152	18	Glass-Filled Thermoplastic

Note: The Self-Clearing Finger Transfer System consists of a finger transfer plate and a transfer edge belt that are designed to work together. This system eliminates the need for a sweeper bar, a pusher arm, or wide transfer plates. Transfers are smooth and 100% self-clearing, making right angle transfers possible for all container types. The Self-Clearing Finger Transfer System is ideal for warmer/cooler applications with frequent product changeovers and is compatible with any series and style of Intralox belt on the discharge and infeed conveyors. This system is bi-directional allowing the same transfer belt to be used for both left-hand and right-hand transfers.

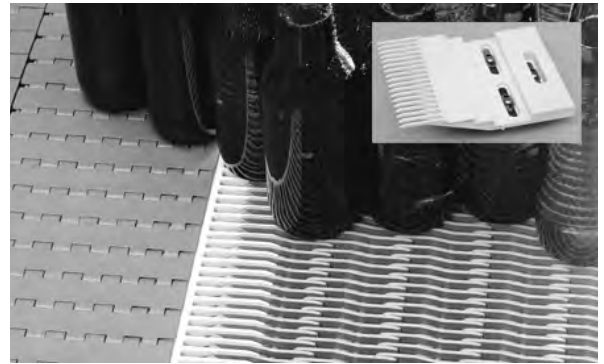

Note: Self-Clearing Finger Transfer System is capable of transferring product to and from Intralox Series 400, Series 1200, and Series 1900 Raised Rib belts.

Note: Smooth, flat top surface provides excellent lateral movement of containers.

Note: Robust design for durability in tough glass applications.

Note: Finger Transfer Plates are easily installed and secured to mounting plates of any thickness with stainless steel bolts and oval washers that allow movement with the belt's expansion and contraction.

Note: Stainless steel hardware is sold separately.

Note: Self-Clearing Transfer Edge belt is molded with robust tracking tabs for belt support in heavy side-loading conditions. It has fully flush edges, headed rod retention system, and nylon rods for superior wear resistance.

a. Licensed under Rexnord U.S. Patent Nos. 7,314,130 and 7,448,490

Conveyor Frame Dimensions

Regardless of type or configuration, all conveyors using Intralox belts have some basic dimensional requirements. Specifically, dimensions "A", "B", "C" and "E" listed below should be implemented in any design.

For general applications and applications where end transfer of tip-sensitive product is not critical, use the "A" dimension at the bottom of the range.

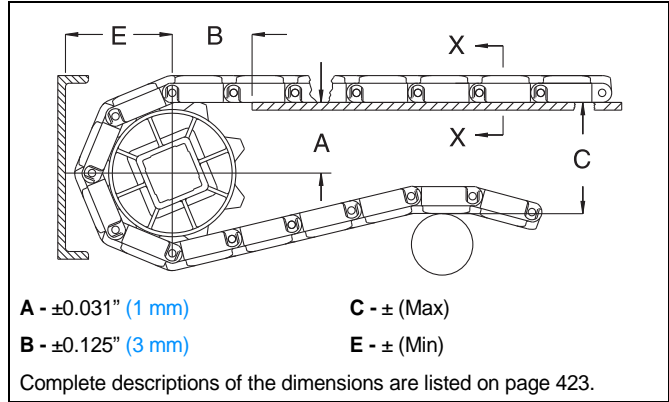

Sprocket Description		A		B		C		E		
Pitch Diameter		No. Teeth	Range (Bottom to Top)		in.	mm	in.	mm	in.	mm
in.	mm		in.	mm						
SERIES 1400 FLAT TOP, FLUSH GRID, EMBEDDED DIAMOND TOP										
3.9	99	12	1.62-1.68	41-43	1.80	46	3.86	98	2.24	57
4.9	124	15	2.10-2.15	53-55	2.06	52	4.81	122	2.72	69
5.1	130	16	2.26-2.32	57-59	2.11	54	5.13	130	2.88	73
5.7	145	18	2.59-2.63	66-67	2.22	56	5.76	146	3.19	81
6.7	170	21	3.07-3.10	78-79	2.44	62	6.71	170	3.75	95
7.7	196	24	3.55-3.58	90-91	2.64	67	7.66	195	4.14	105
9.9	251	31	4.67	119	3.07	78	9.88	251	5.25	133
SERIES 1400 FLAT FRICTION TOP, SQUARE FRICTION TOP, OVAL FRICTION TOP										
3.9	99	12	1.62-1.68	41-43	1.80	46	4.06	103	2.44	62
4.9	124	15	2.10-2.15	53-55	2.06	52	5.01	127	2.92	74
5.1	130	16	2.26-2.31	57-59	2.11	54	5.33	135	3.08	78
5.7	147	18	2.59-2.63	66-67	2.22	56	5.96	151	3.39	86
6.7	170	21	3.07-3.10	78-79	2.44	62	6.91	176	3.87	98
7.7	196	24	3.55-3.58	90-91	2.64	67	7.86	200	4.34	110
9.9	251	31	4.67	119	3.07	78	10.08	256	5.45	138
SERIES 1400 ROLLER TOP										
3.9	99	12	1.62-1.68	41-43	1.80	46	4.66	118	3.04	77
4.9	124	15	2.10-2.15	53-55	2.06	52	5.61	142	3.52	89
5.1	130	16	2.26-2.31	57-59	2.11	54	5.93	151	3.68	93
5.7	145	18	2.59-2.63	66-67	2.22	56	6.56	167	3.99	101
6.7	170	21	3.07-3.10	78-79	2.44	62	7.51	191	4.47	113

Sprocket Description		A		B		C		E		
Pitch Diameter		No. Teeth	Range (Bottom to Top)		in.	mm	in.	mm	in.	mm
in.	mm		in.	mm						
7.7	196	24	3.55-3.58	90-91	2.64	67	8.46	215	4.94	125
9.9	251	31	4.67	119	3.07	78	10.68	271	6.05	154
SERIES 1400 NON SKID, PROTRAX										
3.9	99	12	1.62-1.68	41-43	1.80	46	3.91	99	2.29	58
4.9	124	15	2.05-2.10	52-53	2.06	52	4.86	123	2.77	70
5.1	130	16	2.26-2.31	57-59	2.11	54	5.18	132	2.93	74
5.7	145	18	2.59-2.63	66-67	2.22	56	5.81	148	3.24	82
6.7	170	21	3.07-3.10	78-79	2.44	62	6.76	172	3.72	94
7.7	196	24	3.55-3.58	90-91	2.64	67	7.71	196	4.19	106
9.9	251	31	4.67	119	3.07	78	9.93	252	5.30	135

Dead Plate Gap

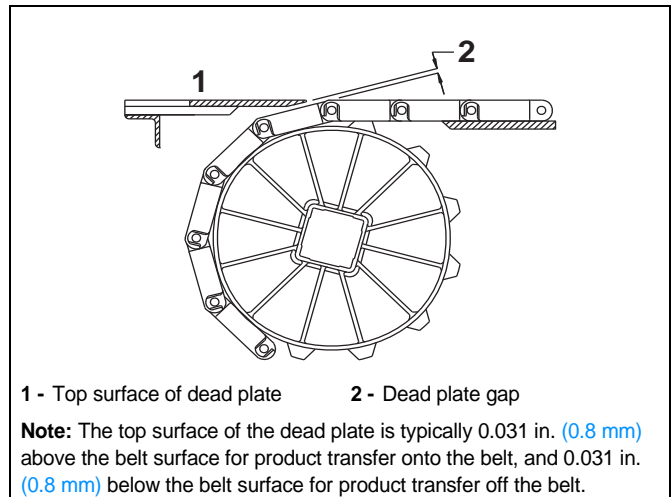

Where there is a transfer point from a belt without finger transfer plates to a dead plate, there should be a gap between the surfaces to allow for the chordal action of the belt. As the belt engages its sprockets, chordal action causes the modules to move past a *fixed* point (the tip of the dead plate) with *varying* clearances. The table below shows the minimum amount of gap which occurs at the “low point” of the modules if the tip of the dead plate just comes in contact with the “high point” as the modules pass.

In some installations it may be desirable to keep the tip of the dead plate in contact with the belt, rather than allow a gap to occur. This can be done by hinging the mounting bracket for the dead plate. This allows the dead plate to move as the modules pass, but results in a small oscillating motion which may present tippage problems for sensitive containers or products.



Sprocket Description			Gap	
Pitch Diameter		No. Teeth	in.	mm
in.	mm			
3.9	99	12	0.066	1.7
4.9	124	15	0.053	1.3
5.1	130	16	0.050	1.3
5.7	145	18	0.044	1.1
6.7	170	21	0.038	1.0
7.7	196	24	0.033	0.8
9.9	251	31	0.025	0.6

Flush Grid		
	in	mm
Pitch	0.50	12.7
Minimum Width	8	203
Width Increments	0.50	12.7
Opening Sizes (approximate)	0.87 × 0.30	22.1 × 7.6
	0.66 × 0.30	16.8 × 7.6
Open Area	48%	
Hinge Style	Open	
Drive Method	Hinge-driven	
Product Notes		
<ul style="list-style-type: none"> • Contact Intralox for precise belt measurements and stock status before designing equipment or ordering a belt. • Designed for a 0.5 in (12.7 mm) nosebar. • Smooth upper surface with fully flush edges. • Uses headless rods. • 0.140 in (3.6 mm) diameter rods. • The detectable material has Surface Resistivity per ASTM_D257 of 545 Ohms per square. 		
Additional Information		
<ul style="list-style-type: none"> • See “Belt Selection Process” (page 5) • See “Standard Belt Materials” (page 9) • See “Special Application Belt Materials” (page 9) • See “Friction Factors” (page 13) 		

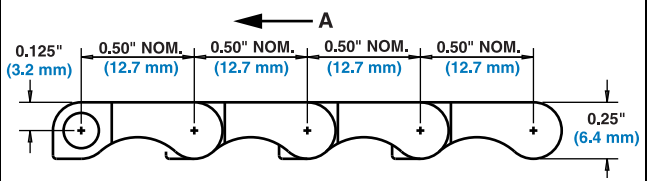



Belt Data							
Belt Material	Standard Rod Material Ø 0.140 in (3.6 mm)	BS Belt Strength		Temperature Range (continuous)		W Belt Weight	
		lb/ft	kg/m	°F	°C	lb/ft ²	kg/m ²
Polypropylene	Polypropylene	125	186	34 to 220	1 to 104	0.44	2.12
Polypropylene	Acetal	150	223	34 to 200	1 to 93	0.51	2.40
HR Nylon ^a	Nylon	175	260	-50 to 240	-46 to 116	0.58	2.83
HHR Nylon	HHR Nylon	175	260	-50 to 310	-46 to 154	0.58	2.83
Acetal	Acetal	240	357	-50 to 200	-46 to 93	0.73	3.56
Detectable Acetal	Acetal	200	298	-50 to 200	-46 to 93	0.69	3.35
Detectable Polypropylene A22	Acetal	80	119	0 to 150	-18 to 66	0.57	2.78
X-Ray Detectable Acetal ^b	Acetal	240	357	-50 to 200	-46 to 93	0.78	3.66

a. This product may not be used for food contact articles that will come in contact with food containing alcohol.
 b. Designed specifically to be detected by x-ray machines.

Flush Grid with Contained Edge

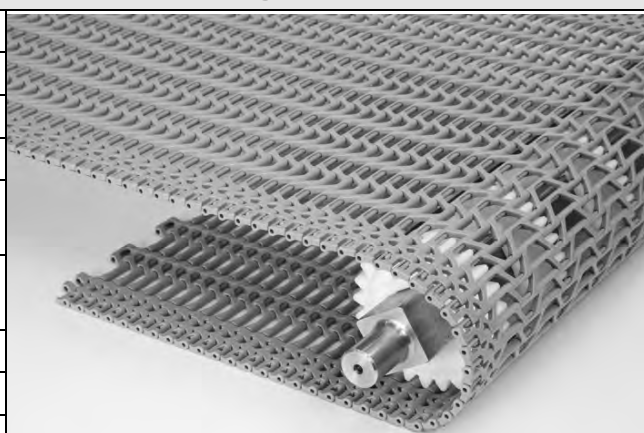
	in	mm
Pitch	0.50	12.7
Minimum Width	8	203
Width Increments	2.0	50.8
Minimum Opening Size (approx.)	0.87 × 0.30	22.1 × 7.6
Maximum Opening Size (approx.)	0.66 × 0.30	16.8 × 7.6
Open Area	48%	
Hinge Style	Open	
Drive Method	Hinge-driven	



Product Notes

- Always check with Customer Service for precise belt width measurement and stock status before designing a conveyor or ordering a belt.
- Available in 2" increments.
- Designed for a 0.5 in (12.7 mm) nosebar.
- Smooth upper surface with fully flush edges.
- Uses headless rods.
- 0.140 in (3.6 mm) diameter rods.
- Recessed rod retention feature provides superior rod containment.

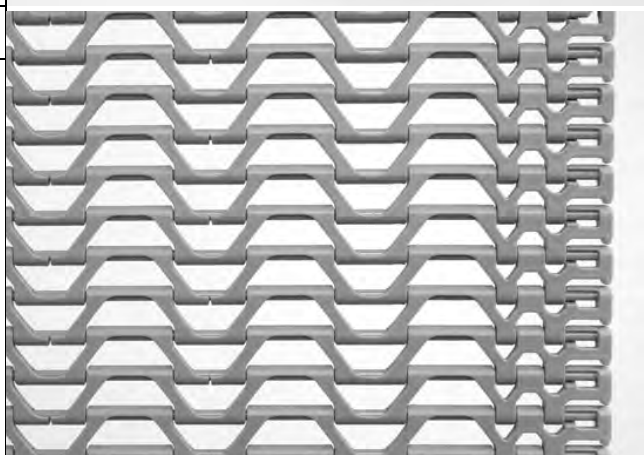

Additional Information

- See "Belt Selection Process" (page 5)
- See "Standard Belt Materials" (page 9)
- See "Special Application Belt Materials" (page 9)
- See "Friction Factors" (page 13)

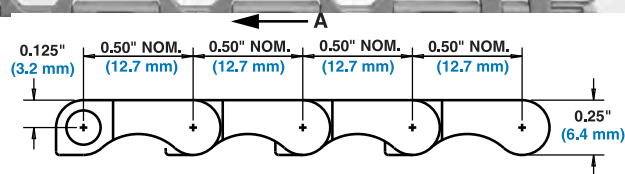

Belt Data

Belt Material	Standard Rod Material Ø 0.180 in (4.6 mm)	BS Belt Strength		Temperature Range (continuous)		W Belt Weight	
		lb/ft	kg/m	°F	°C	lb/ft ²	kg/m ²
HR Nylon ^a	Nylon	175	260	-50 to 240	-46 to 116	0.58	2.83

a. This product may not be used for food contact articles that will come in contact with food containing alcohol.

Sprocket and Support Quantity Reference				
Belt Width Range ^a		Minimum Number of Sprockets Per Shaft ^b	Wearstrips	
in.	mm		Carryway	Returnway
8	203	3	3	2
10	254	3	3	2
12	305	3	3	2
14	356	3	4	3
16	406	5	4	3
18	457	5	4	3
20	508	5	5	3
22	559	5	5	3
24	610	7	5	3
26	660	7	6	4
28	711	7	6	4
30	762	7	6	4
32	813	9	7	4
34	864	9	7	4
36	914	9	7	4
38	965	9	8	5
40	1016	11	8	5
42	1067	11	8	5
44	1118	11	9	5
46	1168	11	9	5
48	1219	13	9	5
50	1270	13	10	6
52	1321	13	10	6
54	1372	13	10	6
56	1422	15	11	6
58	1473	15	11	6
60	1524	15	11	6
62	1575	15	12	7
64	1626	17	12	7
For Other Widths, Use Odd Number of Sprockets ^c at Maximum 4 in. (102 mm) \varnothing Spacing			Maximum 6 in. (152 mm) \varnothing Spacing	Maximum 12 in. (305 mm) \varnothing Spacing

- a. Belts are available in 0.50 in. (12.7 mm) increments beginning with 8 in. (203 mm). If the actual width is critical, consult Customer Service.
- b. These are the minimum number of sprockets. Additional sprockets may be required for heavily loaded applications.
- c. The center sprocket should be locked down. With only two sprockets, fix the sprocket on the drive journal side only. See Locked Sprocket Location chart in the Installation Instruction Guidelines or call Customer Service for lock down location.

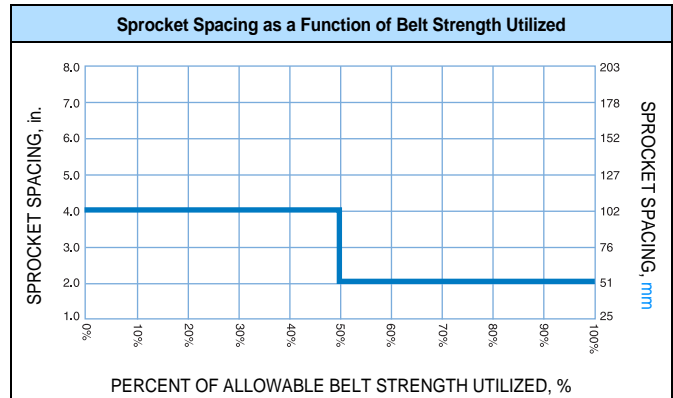
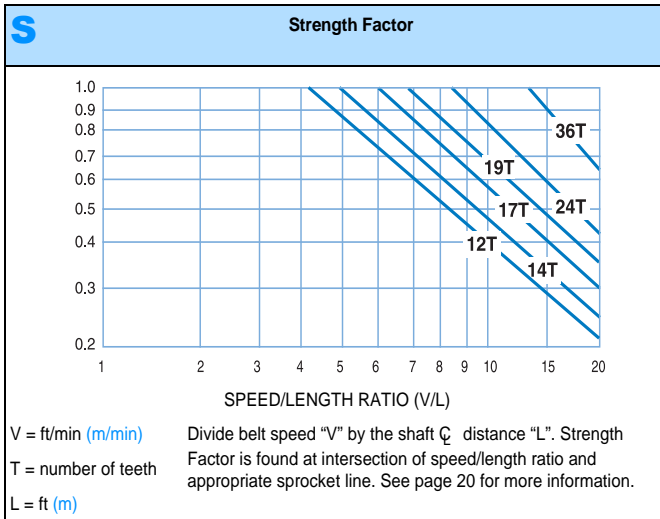

Molded Sprocket ^a										
No. of Teeth (Chordal Action)	Nom. Pitch Dia. in	Nom. Pitch Dia. mm	Nom. Outer Dia. in	Nom. Outer Dia. mm	Nom. Hub Width in	Nom. Hub Width mm	Available Bore Sizes			
							U.S. Sizes		Metric Sizes	
							Round in ^b	Square in	Round mm ^b	Square mm
10 (4.89%)	1.6	41	1.8	46	0.65	17		5/8		
12 (3.41%)	1.9	48	2.1	53	0.65	17	1	1.0	25	
14 (2.51%)	2.3	58	2.4	61	0.75	19	3/4, 1, 1-3/16, 1-1/4	1.0	25	
17 (1.70%)	2.7	69	2.9	73	0.75	19	3/4, 1, 1-3/16, 1-1/4, 1-3/8		25	
19 (1.36%)	3.1	79	3.2	82	0.75	19	1, 1-3/8			
24 (0.86%)	3.8	97	4.0	101	0.75	19	1	1.5	25	40
36 (0.38%)	5.7	145	5.9	150	0.75	19	1	1.5		40

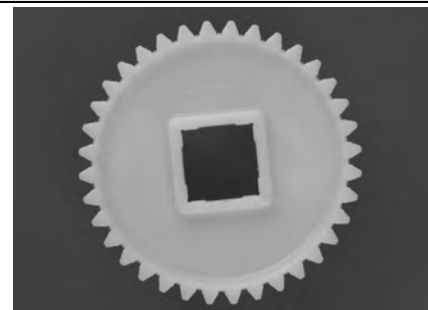

- a. Contact Customer Service for lead times.
- b. Imperial key sizes on round bore sprockets conform to ANSI standard B17.1-1967 (R1989) and metric key sizes conform to DIN standard 6885.

Nylon FDA Split Sprocket ^a										
No. of Teeth (Chordal Action)	Nom. Pitch Dia. in	Nom. Pitch Dia. mm	Nom. Outer Dia. in	Nom. Outer Dia. mm	Nom. Hub Width in	Nom. Hub Width mm	Available Bore Sizes			
							U.S. Sizes		Metric Sizes	
							Round in ^b	Square in	Round mm ^b	Square mm
24 (0.86%)	3.8	97	4.0	101	1.5	38				40
36 (0.38%)	5.7	145	5.9	150	1.5	38				40

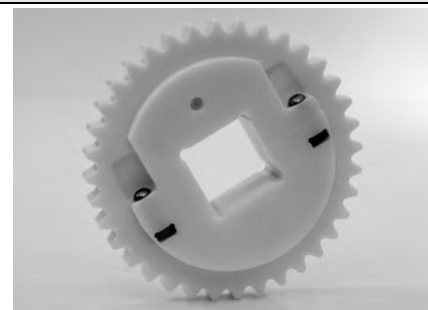

- a. Contact Customer Service for lead times.
- b. Imperial key sizes on round bore sprockets conform to ANSI standard B17.1-1967 (R1989) and metric key sizes conform to DIN standard 6885.

Flush Grid Base Flights (Streamline)		
Available Flight Height		Available Materials
in	mm	
1	25	Acetal, HR Nylon
<p>Note: Flights can be cut down to custom heights with a minimum height of 0.25 in (13 mm).</p> <p>Note: Each flight rises out of the center of its supporting module, molded as an integral part. No fasteners are required.</p> <p>Note: Flush Grid flight is smooth (Streamline) on both sides.</p> <p>Note: The minimum indent is a function of belt width and ranges from 3 in (76 mm) to 3.75 in (95 mm).</p>		



Conveyor Frame Dimensions

Regardless of type or configuration, all conveyors using Intralox belts have some basic dimensional requirements. Specifically, dimensions "A", "B", "C" and "E" listed below should be implemented in any design.

For general applications and applications where end transfer of tip-sensitive product is not critical, use the "A" dimension at the bottom of the range.

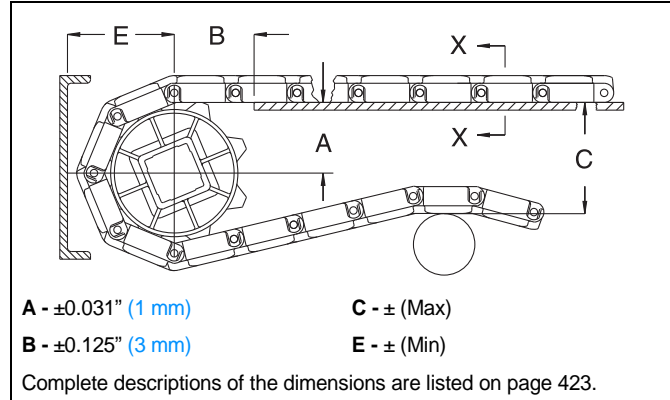

Sprocket Description		A		B		C		E		
Pitch Diameter		No. Teeth	Range (Bottom to Top)		in.	mm	in.	mm	in.	mm
in.	mm		in.	mm						
SERIES 1500 FLUSH GRID, FLUSH GRID WITH CONTAINED EDGE										
1.6	41	10	0.64-0.68	16-17	1.13	29	1.62	41	1.00	25
1.9	48	12	0.81-0.84	21	1.24	31	1.93	49	1.15	29
2.3	58	14	0.97-1.00	25	1.34	34	2.25	57	1.31	33
2.7	69	17	1.21-1.24	31	1.49	38	2.72	69	1.55	39
3.1	79	19	1.37-1.39	35	1.59	40	3.04	77	1.71	43
3.8	97	24	1.77-1.79	45	1.76	45	3.83	97	2.10	53
5.7	145	36	2.73-2.74	69-70	2.71	55	5.74	146	3.06	78

Dead Plate Gap

Where there is a transfer point from a belt without finger transfer plates to a dead plate, there should be a gap between the surfaces to allow for the chordal action of the belt. As the belt engages its sprockets, chordal action causes the modules to move past a *fixed* point (the tip of the dead plate) with *varying* clearances. The table below shows the minimum amount of gap which occurs at the “low point” of the modules if the tip of the dead plate just comes in contact with the “high point” as the modules pass.

In some installations it may be desirable to keep the tip of the dead plate in contact with the belt, rather than allow a gap to occur. This can be done by hinging the mounting bracket for the dead plate. This allows the dead plate to move as the modules pass, but results in a small oscillating motion which may present tippage problems for sensitive containers or products.

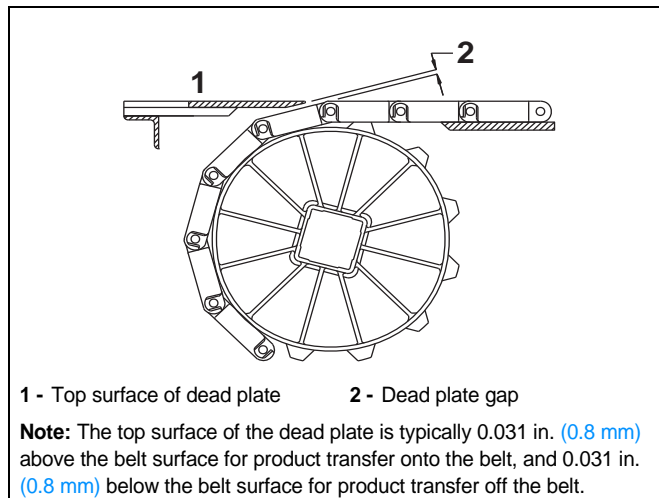

Sprocket Description		Gap		
Pitch Diameter		No. Teeth	in.	mm
in.	mm			
1.6	41	10	0.040	1.0
1.9	48	12	0.033	0.8
2.3	58	14	0.028	0.7
2.7	69	17	0.023	0.6
3.1	79	19	0.021	0.5
3.8	97	24	0.017	0.4
5.7	145	36	0.011	0.3

Open Hinge Flat Top

	in	mm
Pitch (nominal)	1.00	25.4
Minimum Width	5	127
Width Increments	0.50	12.7
Opening Size (approx.)	—	—
Open Area	0%	
Hinge Style	Open	
Drive Method	Center-driven	

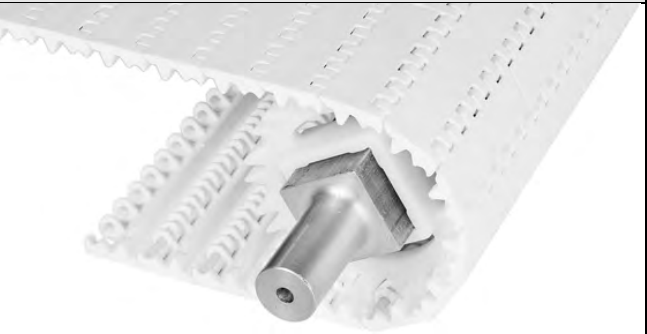

Product Notes

- **Contact Intralox for precise belt measurements and stock status before designing equipment or ordering a belt.**
- Smooth, closed upper surface with fully flush edges and recessed rods.
- Uses headless rods.
- Cam-link designed hinges - expose more hinge and rod area as belt goes around the sprocket. This exclusive Intralox feature allows unsurpassed cleaning access to this area.
- Fully sculpted and radius corners - no pockets or sharp corners to catch and hold debris.
- Like Series 800 and Series 1800, the drive bar on the underside of Series 1600 Open Hinge Flat Top channels water and debris to the outside of the belt for easier, faster cleanup. The drive bar's effectiveness has been proven both in-house and in field tests.
- No-Cling flights are available. Standard height is 4" (102 mm) or they can be cut down to custom heights.

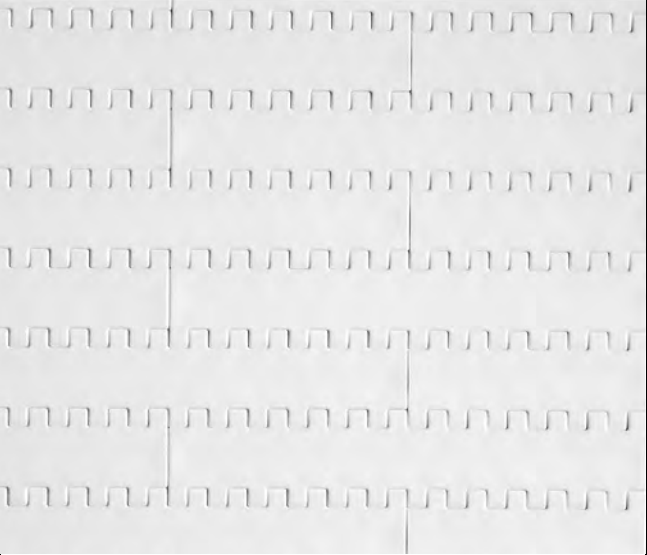

Additional Information

- See "Belt Selection Process" (page 5)
- See "Standard Belt Materials" (page 9)
- See "Special Application Belt Materials" (page 9)
- See "Friction Factors" (page 13)

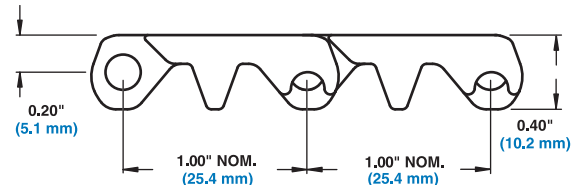

Belt Data

Belt Material	Standard Rod Material Ø 0.18 in (4.6 mm)	BS Belt Strength		Temperature Range (continuous)		W Belt Weight	
		lb/ft	kg/m	°F	°C	lb/ft ²	kg/m ²
Polypropylene	Polypropylene	700	1040	34 to 220	1 to 104	1.05	5.13
Polyethylene	Polyethylene	350	520	-50 to 150	-46 to 66	1.10	5.37
Acetal	Polypropylene	1400	2100	34 to 200	1 to 93	1.58	7.71
Acetal	Polyethylene ^a	1000	1490	-50 to 150	-46 to 66	1.58	7.71
Hi-Temp	Hi-Temp	1000	1488	70 to 400	21 to 204	1.54	7.52
X-Ray Detectable Acetal ^b	Blue Polyethylene	1000	1490	-50 to 150	-46 to 66	1.915	9.35

- a. Polyethylene rods can be used in cold applications when impacts or sudden starts/stops occur. Please note lower rating.
 b. Designed specifically to be detected by x-ray machines

Mold to Width Open Hinge Flat Top

	in	mm
Pitch	1.00	25.4
Molded Width	7.5	190.5
Open Area	0%	
Hinge Style	Open	
Drive Method	Center-Driven	

Product Notes

- Contact Intralox for precise belt measurements and stock status before designing equipment or ordering a belt.
- Tracking tabs provide lateral tracking.
- Uses headed rods.
- Series 1600 Mold to Width belts are boxed in 10 ft. (3.05 m) increments.
- The Series 1600 Mold to Width belt should not be used with sprockets smaller than a 3.9 in (99 mm) diameter (12 tooth) sprocket.
- Smooth, closed upper surface with fully flush edges and recessed headed rods.

Additional Information

- See "Belt Selection Process" (page 5)
- See "Standard Belt Materials" (page 9)
- See "Special Application Belt Materials" (page 9)
- See "Friction Factors" (page 13)

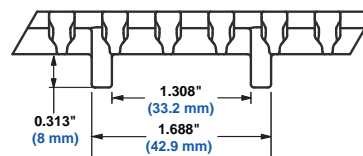
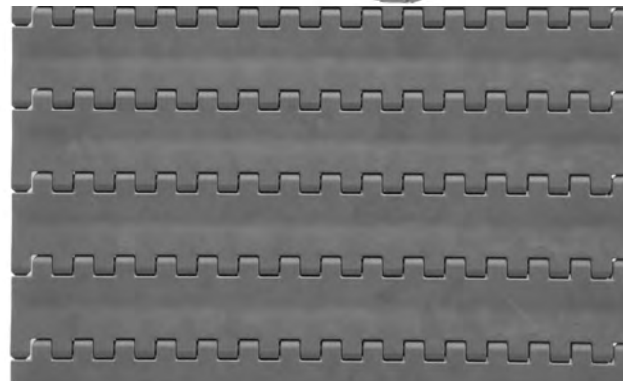
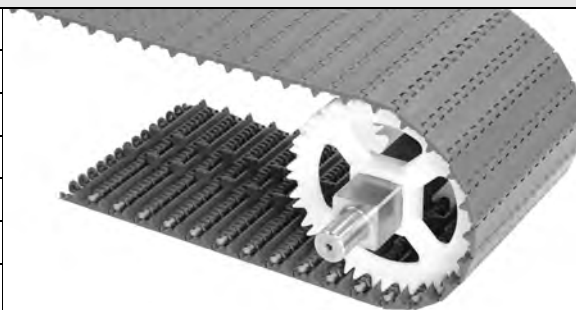

Front view

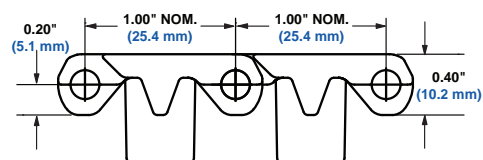

Side view

Belt Data

Belt Material	Standard Rod Material Ø 0.18 in (4.6 mm)	BS		Temperature Range (continuous)		W	
		Belt Strength		°F	°C	Belt Weight	
		lb	kg			lb/ft	kg/m
Acetal	Polyethylene	625	283	-50 to 150	-46 to 66	1.02	1.52

Nub Top™		
	in	mm
Pitch	1.00	25.4
Minimum Width	5	127
Width Increments	0.50	12.7
Open Area	0%	
Product Contact Area	10%	
Hinge Style	Open	
Drive Method	Center-Driven	
Product Notes		
<ul style="list-style-type: none"> • Contact Intralox for precise belt measurements and stock status before designing equipment or ordering a belt. • No-Cling flights are 4 in (102 mm) high and can be cut to any size. Molded as an integral part of the belt, the flights are available in polypropylene, polyethylene, and acetal. • Belt has closed upper surface with fully flush edges. • Uses headless rods. • Recommended for products large enough to span the distance between the nubs [0.250 in (6.35 mm)]. • Standard flights available. • Not recommended for back-up conditions. If values are required, contact Intralox Sales Engineering. • Standard nub indent is 1.3 in (33.0 mm). 		
Additional Information		
<ul style="list-style-type: none"> • See “Belt Selection Process” (page 5) • See “Standard Belt Materials” (page 9) • See “Special Application Belt Materials” (page 9) • See “Friction Factors” (page 13) 		

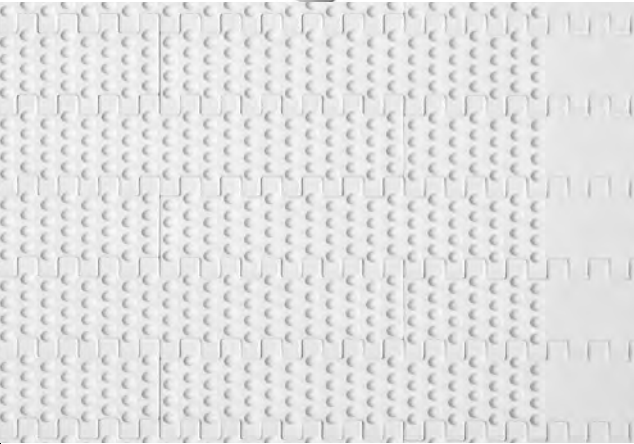
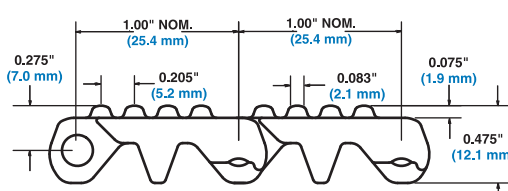



Belt Data							
Belt Material	Standard Rod Material Ø 0.18 in (4.6 mm)	BS Belt Strength		Temperature Range (continuous)		W Belt Weight	
		lb/ft	kg/m	°F	°C	lb/ft ²	kg/m ²
Polypropylene	Polypropylene	700	1040	34 to 220	1 to 104	1.13	5.52
Polyethylene	Polyethylene	350	520	-50 to 150	-46 to 66	1.18	5.76
Acetal	Polypropylene	1400	2100	34 to 200	1 to 93	1.74	8.49
Acetal	Polyethylene ^a	1000	1490	-50 to 150	-46 to 66	1.74	8.49
X-Ray Detectable Acetal	X-Ray Detectable Acetal	1400	2083	-50 to 200	-46 to 93	2.01	9.81

a. Polyethylene rods can be used in cold applications when impacts or sudden starts/stops occur. Please note lower rating.

Mini Rib

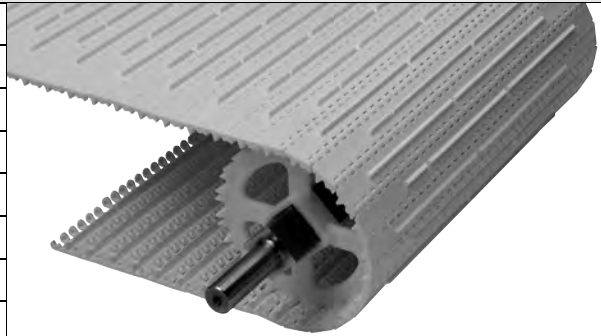
	in	mm
Pitch (nominal)	1.00	25.4
Minimum Width	5	127
Width Increments	0.50	12.7
Opening Size (approx.)	—	—
Open Area	0%	
Hinge Style	Open	
Drive Method	Center-driven	



Product Notes

- **Contact Intralox for precise belt measurements and stock status before designing equipment or ordering a belt.**
- Closed upper surface with fully flush edges.
- Cam-link designed hinges - expose more hinge and rod area as belt goes around the sprocket. This exclusive Intralox feature allows unsurpassed cleaning access to this area.
- Uses headless rods.
- Fully sculpted and radius corners - no pockets or sharp corners to catch and hold debris.
- Like Series 800 and Series 1800, the drive bar on the underside of Series 1600 Open Hinge Mini Rib channels water and debris to the outside of the belt for easier, faster cleanup. The drive bar's effectiveness has been proven both in-house and in field tests.
- No-Cling flights are available. Standard height is 4 in (102 mm) or they can be cut down to custom heights.
- 0.16 in (4 mm) Mini Rib on surface accommodates gradual inclines and declines. Not recommended for back-up conditions.
- Minimum nominal alternating edge indents of 1.5 in (38 mm) and 2 in (51 mm).

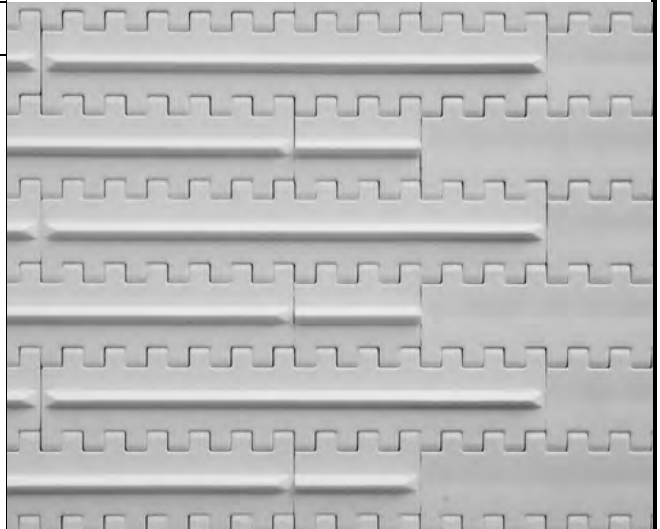

Additional Information

- See "Belt Selection Process" (page 5)
- See "Standard Belt Materials" (page 9)
- See "Special Application Belt Materials" (page 9)
- See "Friction Factors" (page 13)

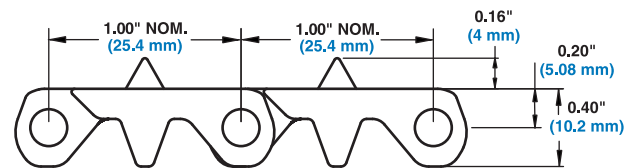

Belt Data

Belt Material	Standard Rod Material Ø 0.18 in (4.6 mm)	BS Belt Strength		Temperature Range (continuous)		W Belt Weight	
		lb/ft	kg/m	°F	°C	lb/ft ²	kg/m ²
Polypropylene	Polypropylene	700	1040	34 to 220	1 to 104	1.135	5.54
Acetal	Polypropylene	1400	2100	34 to 200	1 to 93	1.705	8.32

Mesh Top™		
	in	mm
Pitch	1.00	25.4
Minimum Width	5	127
Width Increments	0.50	12.7
Min. Opening Size (approx.)	0.06 x 0.12	1.5 x 3.0
Max. Opening Size (approx.)	0.06 x 0.20	1.5 x 5.1
Open Area	16%	
Hinge Style	Open	
Drive Method	Center-driven	
Product Notes		
<ul style="list-style-type: none"> • Contact Intralox for precise belt measurements and stock status before designing equipment or ordering a belt. • Cam-link designed hinges - expose more hinge and rod area as belt goes around the sprocket. This exclusive Intralox feature allows unsurpassed cleaning access to this area. • Uses headless rods. • Fully sculpted and radius corners - no pockets or sharp corners to catch and hold debris. • Like Series 800 and Series 1800, the drive bar on the underside of Series 1600 Mesh Top channels water and debris to the outside of the belt for easier, faster cleanup. The drive bar's effectiveness has been proven both in-house and in field tests. • No-Cling flights are available. Standard height is 4 in (102 mm) or they can be cut down to custom heights. • Standard Mesh Top indent is 1.0 in (25.4 mm). 		
Additional Information		
<ul style="list-style-type: none"> • See "Belt Selection Process" (page 5) • See "Standard Belt Materials" (page 9) • See "Special Application Belt Materials" (page 9) • See "Friction Factors" (page 13) 		

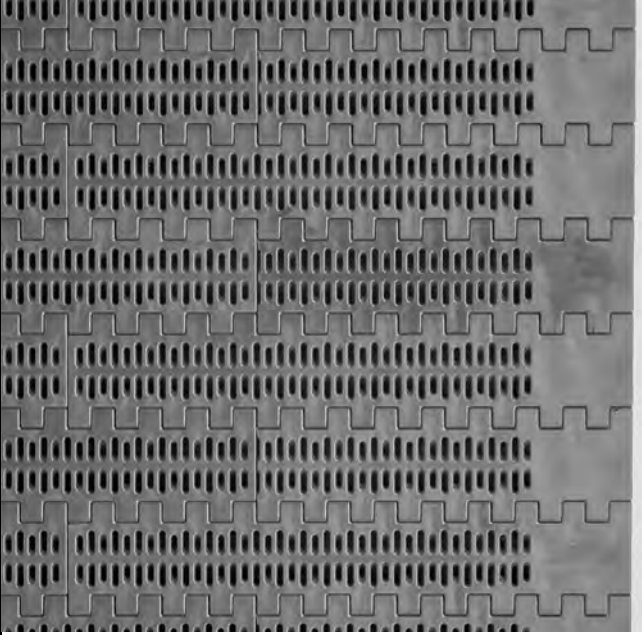
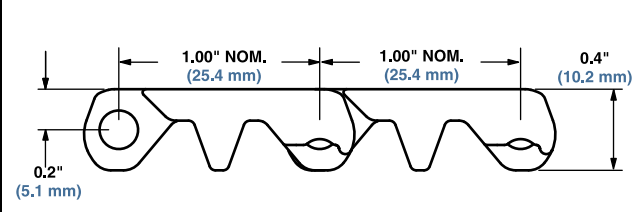
Belt Data							
Belt Material	Standard Rod Material Ø 0.18 in (4.6 mm)	BS		Temperature Range (continuous)		W	
		lb/ft	kg/m	°F	°C	lb/ft ²	kg/m ²
Acetal	Polypropylene	1200	1780	34 to 200	1 to 93	1.40	6.84
Polypropylene	Polypropylene	700	1040	34 to 220	1 to 104	0.94	4.59

Mesh Nub Top™

	in	mm
Pitch	1.00	25.4
Minimum Width	5	127
Width Increments	0.50	12.7
Min. Opening Size (approx.)	0.06 x 0.12	1.5 x 3.0
Max. Opening Size (approx.)	0.06 x 0.20	1.5 x 5.1
Open Area	16%	
Hinge Style	Open	
Drive Method	Center-Driven	

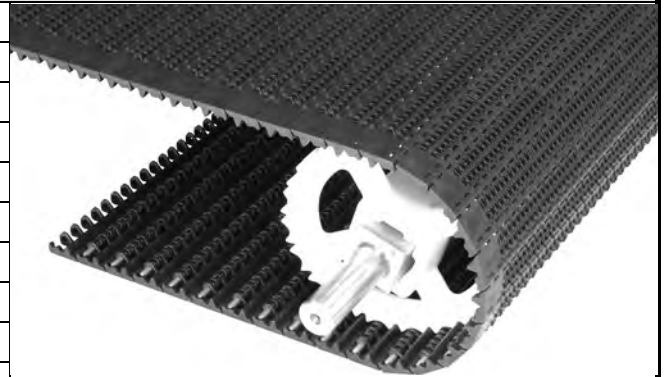

Product Notes

- **Contact Intralox for precise belt measurements and stock status before designing equipment or ordering a belt.**
- Fully sculpted and radius corner – no pockets or sharp corners to catch and hold debris.
- Uses headless rods.
- Like Series 800 and Series 1800, the drive bar on the underside of the S1600 Mesh Nub Top channels water and debris to the outside of the belt for easier, faster cleanup. The drive bar's effectiveness has been proven both in-house and in field tests.
- No Cling flights are available. Standard height is 4 in (102 mm) or they can be cut down to custom heights.
- Standard Mesh Nub Top indent is 1.0 in (25.4 mm).

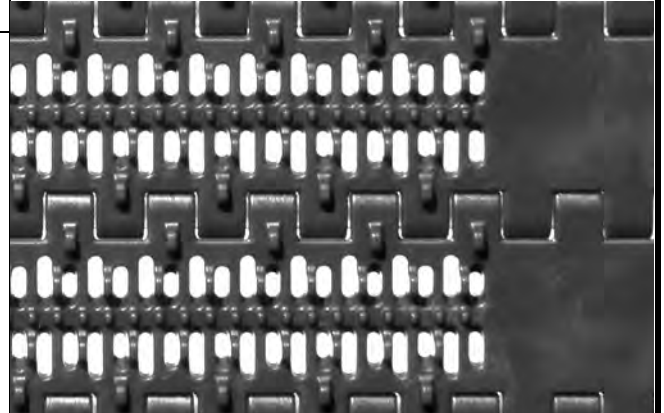

Additional Information

- See "Belt Selection Process" (page 5)
- See "Standard Belt Materials" (page 9)
- See "Special Application Belt Materials" (page 9)
- See "Friction Factors" (page 13)

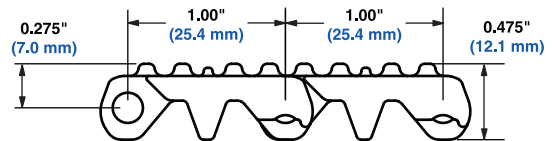

Belt Data

Belt Material	Standard Rod Material Ø 0.18 in (4.6 mm)	BS		Temperature Range (continuous)		W	
		Belt Strength		°F	°C	Belt Weight	
		lb/ft	kg/m			lb/ft²	kg/m²
Acetal	Polypropylene	1200	1780	34 to 200	1 to 93	1.45	7.08
Polypropylene	Polypropylene	700	1040	34 to 220	1 to 104	0.98	4.81

Raised Open Grid			
	in	mm	
Pitch	1.00	25.4	
Minimum Width	5	127	
Maximum Width	60	1524	
Width Increments	0.50	12.7	
Opening Size (approx.)	0.20 x 0.16	5.1 x 4.1	
Open Area	28%		
Min. Open Area	n/a		
Hinge Style	Open		
Drive Method	Center-Driven		
Product Notes			
<ul style="list-style-type: none"> • Contact Intralox for precise belt measurements and stock status before designing equipment or ordering a belt. • Fully sculpted and radius corners - no pockets or sharp corners to catch and hold debris. • Uses headless rods. • Like Series 800 and Series 1800, the drive bar on the underside of Series 1600 Raised Open Grid channels water and debris to the outside of the belt for easier, faster cleanup. The drive bar's effectiveness has been proven both in-house and in field tests. • Open area designed to limit water film formation and maximize water drainage. • Standard Raised Open Grid indent is 1 in (25.4 mm). 			
Additional Information			
<ul style="list-style-type: none"> • See "Belt Selection Process" (page 5) • See "Standard Belt Materials" (page 9) • See "Special Application Belt Materials" (page 9) • See "Friction Factors" (page 13) 			

SECTION 2

1600

Belt Data							
Belt Material	Standard Rod Material Ø 0.18 in (4.6 mm)	BS Belt Strength		Temperature Range (continuous)		W Belt Weight	
		lb/ft	kg/m	°F	°C	lb/ft ²	kg/m ²
Acetal	Polypropylene	800	1190	34 to 200	1 to 93	1.32	6.44
Polypropylene	Polypropylene	400	595	34 to 220	1 to 104	0.89	4.35
Polyethylene	Polyethylene	200	298	-50 to 150	-46 to 66	0.92	4.49

Sprocket and Support Quantity Reference				
Belt Width Range ^a		Minimum Number of Sprockets Per Shaft ^b	Wearstrips	
in.	mm		Carryway	Returnway
5	127	2	2	2
6	152	2	2	2
7	178	2	3	2
8	203	3	3	2
9	229	3	3	2
10	254	3	3	2
12	305	3	3	2
14	356	5	4	3
15	381	5	4	3
16	406	5	4	3
18	457	5	4	3
20	508	5	5	3
24	610	7	5	3
30	762	9	6	4
32	813	9	7	4
36	914	9	7	4
42	1067	11	8	5
48	1219	13	9	5
54	1372	15	10	6
60	1524	15	11	6
72	1829	19	13	7
84	2134	21	15	8
96	2438	25	17	9
120	3048	31	21	11
144	3658	37	25	13
For Other Widths, Use Odd Number of Sprockets ^c at Maximum 4 in. (102 mm) \varnothing Spacing			Maximum 6 in. (152 mm) \varnothing Spacing	Maximum 12 in. (305 mm) \varnothing Spacing

- a. Belts are available in 0.50 in. (12.7 mm) increments beginning with 5 in. (127 mm). If the actual width is critical, consult Customer Service.
- b. These are the minimum number of sprockets. Additional sprockets may be required for heavily loaded applications.
- c. The center sprocket should be locked down. With only two sprockets, fix the sprocket on the drive journal side only. See Retainer Rings/Center Sprocket Offset chart on page 410 for lock down location.

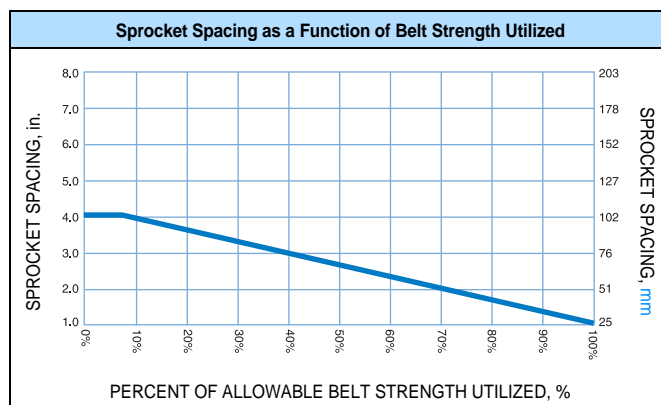
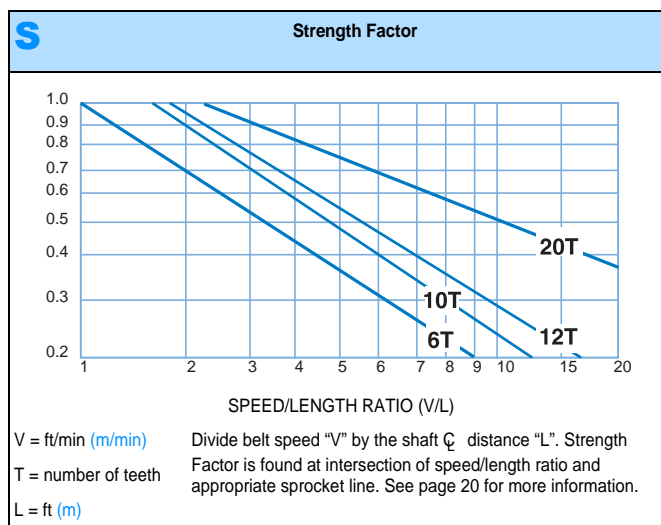

EZ Clean™ Sprocket^a										
No. of Teeth (Chordal Action)	Nom. Pitch Dia. in	Nom. Pitch Dia. mm	Nom. Outer Dia. in	Nom. Outer Dia. mm	Nom. Hub Width in	Nom. Hub Width mm	Available Bore Sizes			
							U.S. Sizes		Metric Sizes	
							Round in ^b	Square in	Round mm ^b	Square mm
6 (13.40%)	2.0	51	1.8	46	1.0	25	1.0		25	
10 (4.89%)	3.2	81	3.2	81	1.0	25	1.0	1.5	25	40
12 (3.41%)	3.9	99	3.8	97	1.0	25		1.5		40
20 (1.23%)	6.4	163	6.4	163	1.0	25		1.5		40



- a. Contact Customer Service for lead times. When using polyurethane sprockets, the Belt Strength for belts rated over 500 lb/ft (744 kg/m) will be de-rated to 500 lb/ft (744 kg/m) and all other belts will maintain their published rating. The temperature range for Polyurethane sprockets is 0° F (-18 °C) to 120 °F (49 °C). Contact Customer Service for availability of Polyurethane sprockets.
- b. Imperial key sizes on round bore sprockets conform to ANSI standard B17.1-1967 (R1989) and metric key sizes conform to DIN standard 6885.

Angled EZ Clean™ Sprocket^a										
No. of Teeth (Chordal Action)	Nom. Pitch Dia. in	Nom. Pitch Dia. mm	Nom. Outer Dia. in	Nom. Outer Dia. mm	Nom. Hub Width in	Nom. Hub Width mm	Available Bore Sizes			
							U.S. Sizes		Metric Sizes	
							Round in	Square in	Round mm	Square mm
12 (3.41%)	3.9	99	3.8	97	2.0	50.8		1.5		40
16 (1.92%)	5.2	132	5.1	130	2.0	50.8		1.5		40
20 (1.23%)	6.4	163	6.4	163	2.0	50.8		1.5		40

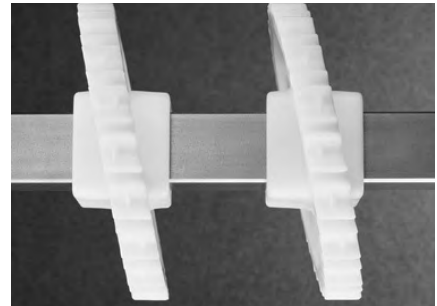

- a. Contact Customer Service for lead times.

UHMW Polyethylene Sprocket^a										
No. of Teeth (Chordal Action)	Nom. Pitch Dia. in	Nom. Pitch Dia. mm	Nom. Outer Dia. in	Nom. Outer Dia. mm	Nom. Hub Width in	Nom. Hub Width mm	Available Bore Sizes			
							U.S. Sizes		Metric Sizes	
							Round in	Square in	Round mm	Square mm
16 (1.92%)	5.3	135	5.1	130	1.0	25				40



- a. Contact Customer Service for lead times.

Open Hinge Flat Top Base Flight (No-Cling)

Available Flight Height		Available Materials
in	mm	
4.0	102	Polypropylene, Polyethylene, Acetal



Note: Minimum indent is 1.0 in (25.4 mm)

Note: Flights can be cut down to custom heights with a minimum height of 0.25 in (13 mm).

Note: Each flight rises out of the center of its supporting module, molded as an integral part. No fasteners are required.

Note: The no-cling vertical ribs are on both sides of the flight.

Mesh Nub Top™ Base Flight (No-Cling)

Available Flight Height		Available Materials
in	mm	
4.0	102	Acetal, Polyethylene

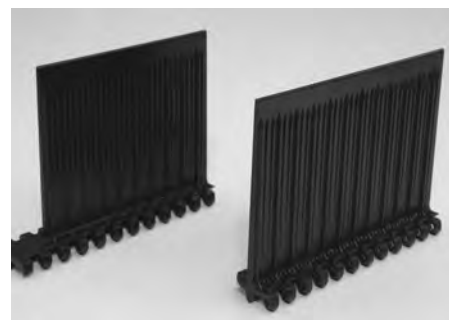

Note: Minimum indent is 1.0 in (25.4 mm)

Note: Flights can be cut down to custom heights with a minimum height of 0.25 in (13 mm).

Note: Each flight rises out of the center of its supporting module, molded as an integral part. No fasteners are required.

Note: The no-cling vertical ribs are on both sides of the flight.

Sideguards

Available Sizes		Available Materials
in	mm	
2	51	Polypropylene
3	76	



Note: The minimum indent is 0.7 in (18mm)

Note: The normal gap between the sideguards and the edge of a flight is 0.3 in (7.6 mm).

Note: When going around the 6 and 10 tooth sprocket, the sideguards will fan out, opening a gap at the top of the sideguard which may allow small products to fall out. The sideguards stay completely closed when going around the 12, 16, and 20 tooth sprockets.

Note: Standard sideguard orientation is angled inward toward the product (product friendly). If needed, sideguards can be angled outward toward the conveyor.

Conveyor Frame Dimensions

Regardless of type or configuration, all conveyors using Intralox belts have some basic dimensional requirements. Specifically, dimensions "A", "B", "C" and "E" listed below should be implemented in any design.

For general applications and applications where end transfer of tip-sensitive product is not critical, use the "A" dimension at the bottom of the range.

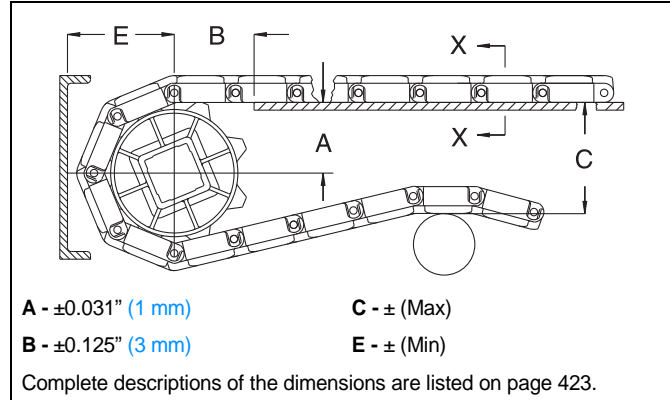

Sprocket Description		A		B		C		E		
Pitch Diameter		No. Teeth	Range (Bottom to Top)		in.	mm	in.	mm	in.	mm
in.	mm		in.	mm						
SERIES 1600 OPEN HINGE FLAT TOP, MESH TOP										
2.0	51	6	0.67-0.80	17-20	1.10	28	2.00	51	1.26	32
3.2	81	10	1.34-1.42	34-36	1.56	40	3.24	82	1.88	48
3.9	99	12	1.67-1.73	42-44	1.70	43	3.86	98	2.19	56
5.2	132	16	2.31-2.36	59-60	1.99	51	5.13	130	2.83	72
6.4	163	20	2.96-3.00	75-76	2.25	57	6.39	162	3.46	88
SERIES 1600 NUB TOP, MESH NUB TOP										
2.0	51	6	0.67-0.80	17-20	1.10	28	2.08	53	1.34	34
3.2	81	10	1.34-1.42	34-36	1.56	40	3.31	84	1.96	50
3.9	99	12	1.67-1.73	42-44	1.70	43	3.94	100	2.27	58
5.2	132	16	2.31-2.36	59-60	1.99	51	5.13	130	2.83	72
6.4	163	20	2.96-3.00	75-76	2.25	57	6.47	164	3.53	90
SERIES 1600 MINI RIB										
2.0	51	6	0.67-0.80	17-20	1.10	28	2.16	55	1.42	36
3.2	81	10	1.34-1.42	34-36	1.56	40	3.40	86	2.04	52
3.9	99	12	1.67-1.73	42-44	1.70	43	4.02	102	2.35	60
5.2	132	16	2.31-2.36	59-60	1.99	51	5.13	130	2.83	72
6.4	163	20	2.96-3.00	75-76	2.25	57	6.55	166	3.62	92

Dead Plate Gap

Where there is a transfer point from a belt without finger transfer plates to a dead plate, there should be a gap between the surfaces to allow for the chordal action of the belt. As the belt engages its sprockets, chordal action causes the modules to move past a *fixed* point (the tip of the dead plate) with *varying* clearances. The table below shows the minimum amount of gap which occurs at the “low point” of the modules if the tip of the dead plate just comes in contact with the “high point” as the modules pass.

In some installations it may be desirable to keep the tip of the dead plate in contact with the belt, rather than allow a gap to occur. This can be done by hinging the mounting bracket for the dead plate. This allows the dead plate to move as the modules pass, but results in a small oscillating motion which may present tippage problems for sensitive containers or products.

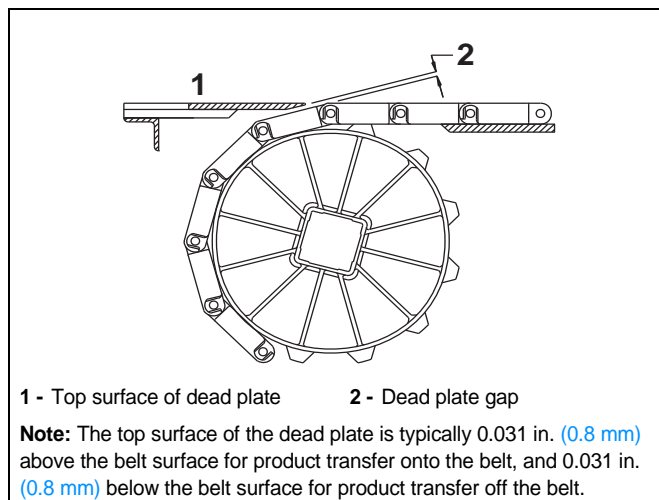

Sprocket Description		Gap		
Pitch Diameter		No. Teeth	in.	mm
in.	mm			
2.0	51	6	0.134	3.4
3.2	81	10	0.079	2.0
3.9	99	12	0.066	1.7
6.4	163	20	0.039	1.0

SeamFree™ Minimum Hinge Flat Top

	in	mm
Pitch	1.00	25.4
Minimum Width	4	102
Width Increments	1.00	25.4
Opening Sizes (approx.)	-	-
Open Area	0%	
Hinge Style	Open	
Drive Method	Center-Driven	

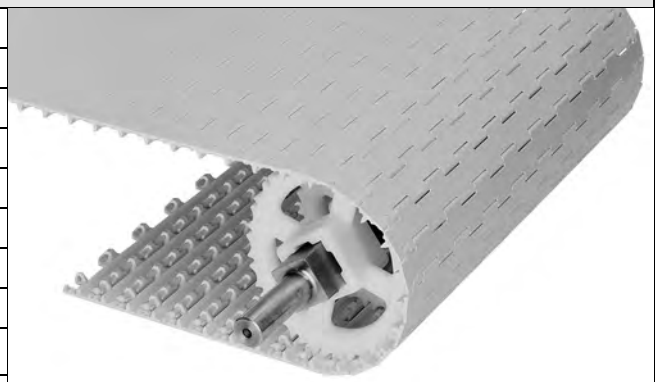

Product Notes

- **Contact Intralox for precise belt measurements and stock status before designing equipment or ordering a belt.**
- Smooth, closed upper surface with fully flush edges.
- Uses headed rods.
- Cam-link designed hinges - expose more hinge and rod area as the belt goes around the sprocket. This exclusive Intralox feature allows unsurpassed cleaning access to this area.
- Fully sculpted and radiused corners - no pockets or sharp corners to catch and hold debris.
- The drive bar on the underside of S1650 SeamFree Minimum Hinge Flat Top, in combination with the patent pending flume feature, channels water and debris to the outside of the belt for easier, faster cleanup. The drive bar's effectiveness has been proven both in-house and in field tests.
- Designed for use with S1600 Angled EZ Clean™ sprockets but compatible with standard S1600 EZ Clean sprockets as well.
- Belts over 18 in (457 mm) are built with multiple modules per row, but seams are minimized.

Additional Information

- See "Belt Selection Process" (page 5)
- See "Standard Belt Materials" (page 9)
- See "Special Application Belt Materials" (page 9)
- See "Friction Factors" (page 13)

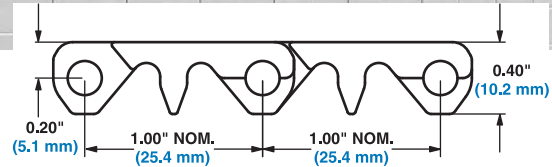
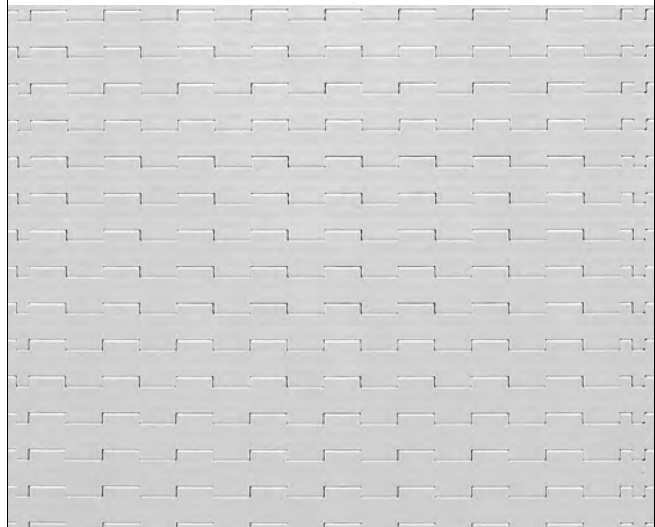

Belt Data

Belt Material	Standard Rod Material Ø 0.18 in (4.6 mm)	BS Belt Strength		Temperature Range (continuous)		W Belt Weight	
		lb/ft	kg/m	°F	°C	lb/ft ²	kg/m ²
Acetal	Acetal	350	520	-50 to 200	-46 to 93	1.47	7.18
Acetal	Polypropylene	325	480	34 to 200	1 to 93	1.40	6.84
Acetal	Polyethylene	225	330	-50 to 150	-46 to 66	1.40	6.83
Polypropylene	Polypropylene	225	330	34 to 220	1 to 104	0.91	4.44
X-Ray Detectable Acetal	Acetal	350	521	-50 to 200	-46 to 93	1.74	8.50

Sprocket and Support Quantity Reference				
Belt Width Range ^a		Minimum Number of Sprockets Per Shaft ^b	Wearstrips	
in.	mm		Carryway	Returnway
4	102	2	2	2
5	127	2	2	2
6	152	2	2	2
7	178	2	3	2
8	203	3	3	2
9	229	3	3	2
10	254	3	3	2
12	305	3	3	2
14	356	5	4	3
15	381	5	4	3
16	406	5	4	3
18	457	5	4	3
20	508	5	5	3
24	610	7	5	3
30	762	9	6	4
32	813	9	7	4
36	914	9	7	4
42	1067	11	8	5
48	1219	13	9	5
54	1372	15	10	6
60	1524	15	11	6
72	1829	19	13	7
84	2134	21	15	8
96	2438	25	17	9
120	3048	31	21	11
144	3658	37	25	13
For Other Widths, Use Odd Number of Sprockets ^c at Maximum 4 in. (102 mm) \varnothing Spacing			Maximum 6 in. (152 mm) \varnothing Spacing	Maximum 12 in. (305 mm) \varnothing Spacing

- a. Belts are available in 1.0 in. (25.4 mm) increments beginning with 4 in. (101.6 mm). If the actual width is critical, consult Customer Service.
- b. These are the minimum number of sprockets. Additional sprockets may be required for heavily loaded applications.
- c. The center sprocket should be locked down. With only two sprockets, fix the sprocket on the drive journal side only.

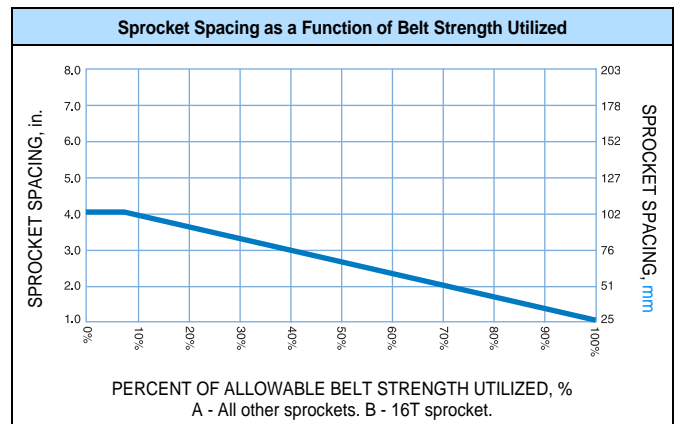
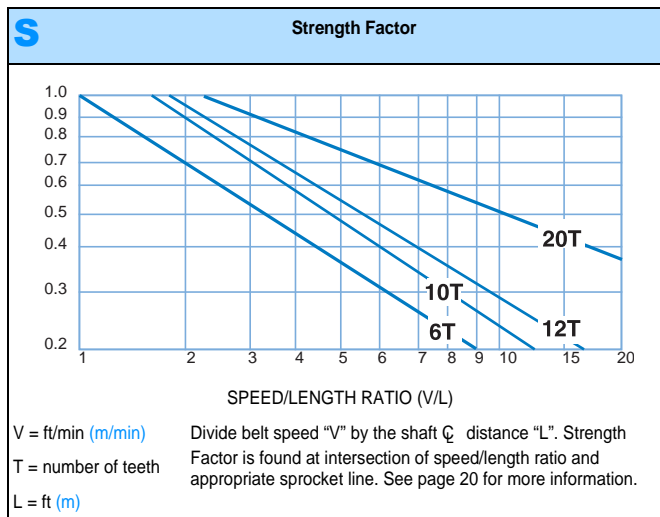

EZ Clean Sprocket^a										
No. of Teeth (Chordal Action)	Nom. Pitch Dia. in	Nom. Pitch Dia. mm	Nom. Outer Dia. in	Nom. Outer Dia. mm	Nom. Hub Width in	Nom. Hub Width mm	Available Bore Sizes			
							U.S. Sizes		Metric Sizes	
							Round in ^b	Square in	Round mm ^b	Square mm
6 (13.40%)	2.0	51	1.8	46	1.0	25	1.0		25	
10 (4.89%)	3.2	81	3.2	81	1.0	25	1.0	1.5	25	40
12 (3.41%)	3.9	99	3.8	97	1.0	25		1.5		40
20 (1.23%)	6.4	163	6.4	163	1.0	25		1.5		40



- a. Contact Customer Service for lead times. When using Polyurethane sprockets, the Belt Strength for belts rated over 500 lb/ft (744 kg/m) will be de-rated to 500 lb/ft (744 kg/m) and all other belts will maintain their published rating. The temperature range for Polyurethane sprockets is 0° F (-18 °C) to 120 °F (49 °C). Contact Customer Service for availability of Polyurethane sprockets.
- b. Imperial key sizes on round bore sprockets conform to ANSI standard B17.1-1967 (R1989) and metric key sizes conform to DIN standard 6885.

Angled EZ Clean Sprocket^a										
No. of Teeth (Chordal Action)	Nom. Pitch Dia. in	Nom. Pitch Dia. mm	Nom. Outer Dia. in	Nom. Outer Dia. mm	Nom. Hub Width in	Nom. Hub Width mm	Available Bore Sizes			
							U.S. Sizes		Metric Sizes	
							Round in	Square in	Round mm	Square mm
12 (3.41%)	3.9	99	3.8	97	2.0	50.8		1.5		40
16 (1.92%)	5.2	132	5.1	130	2.0	50.8		1.5		40
20 (1.23%)	6.4	163	6.4	163	2.0	50.8		1.5		40

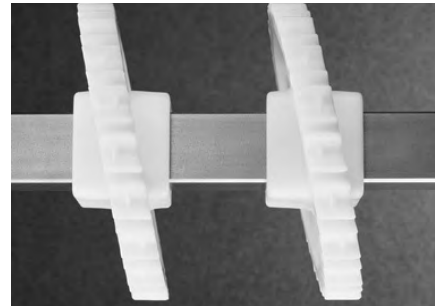

- a. Contact Customer Service for lead times.

Minimum Hinge Flat Top Base Flight (Double No-Cling)		
Available Flight Height		Available Materials
in	mm	
3.0	76.2	
		Polypropylene, Acetal

Note: Flights can be cut down to a minimum height of 0.5 in (12.7 mm)

Note: Flights of even inch widths come standard with 1 in (25.4 mm) indents. Flights of odd inch widths are available for retrofits and require machined indents, which have contain marks and evidence of modification.

Note: Each flight rises out of the center of its supporting module, molded as an integral part. No fasteners are required.

Note: The no-cling vertical ribs are on both sides of the flight.

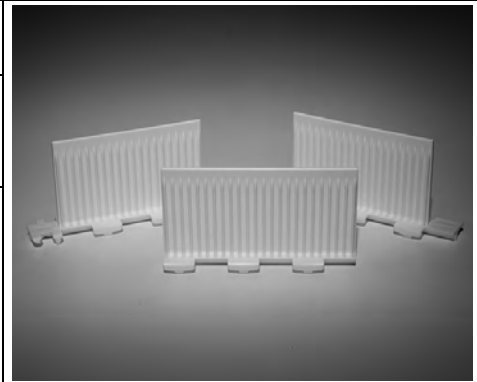

Conveyor Frame Dimensions

Regardless of type or configuration, all conveyors using Intralox belts have some basic dimensional requirements. Specifically, dimensions “A”, “B”, “C” and “E” listed below should be implemented in any design.

For general applications and applications where end transfer of tip-sensitive product is not critical, use the “A” dimension at the bottom of the range.

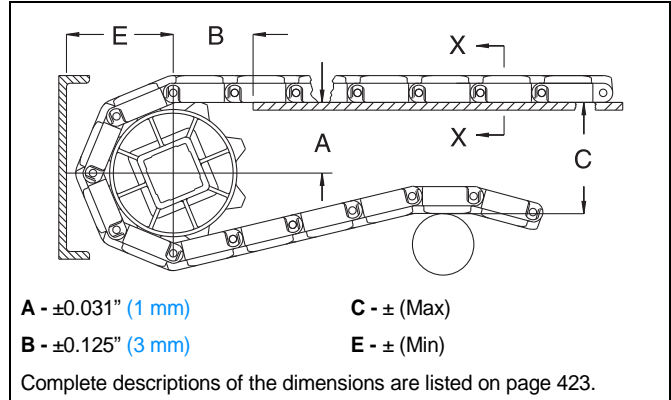

Sprocket Description		A		B		C		E		
Pitch Diameter		No. Teeth	Range (Bottom to Top)		in.	mm	in.	mm	in.	mm
in.	mm		in.	mm						
SERIES 1650 SEAMFREE™ MINIMUM HINGE FLAT TOP										
2.0	51	6	0.67-0.80	17-20	1.10	28	2.00	51	1.26	32
3.2	81	10	1.34-1.42	34-36	1.56	40	3.24	82	1.88	48
3.9	99	12	1.67-1.73	42-44	1.70	43	3.86	98	2.19	56
5.2	132	16	2.31-2.36	59-60	1.99	51	5.13	130	2.83	72
6.4	163	20	2.96-3.00	75-76	2.25	57	6.40	163	3.46	88

Dead Plate Gap

Where there is a transfer point from a belt without finger transfer plates to a dead plate, there should be a gap between the surfaces to allow for the chordal action of the belt. As the belt engages its sprockets, chordal action causes the modules to move past a *fixed* point (the tip of the dead plate) with *varying* clearances. The table below shows the minimum amount of gap which occurs at the “low point” of the modules if the tip of the dead plate just comes in contact with the “high point” as the modules pass.

In some installations it may be desirable to keep the tip of the dead plate in contact with the belt, rather than allow a gap to occur. This can be done by hinging the mounting bracket for the dead plate. This allows the dead plate to move as the modules pass, but results in a small oscillating motion which may present tipping problems for sensitive containers or products.

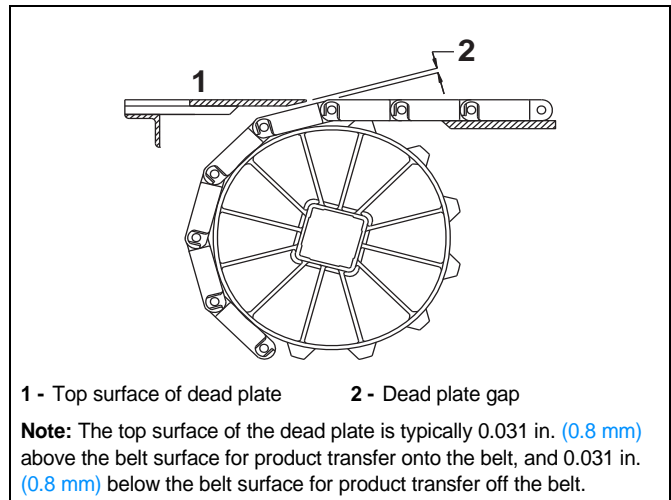

Sprocket Description			Gap	
Pitch Diameter		No. Teeth	in.	mm
in.	mm			
2.0	51	6	0.134	3.4
3.2	81	10	0.079	2.0
3.9	99	12	0.066	1.7
6.4	163	20	0.039	1.0

Flush Grid		
	in	mm
Pitch	1.50	38.1
Minimum Width	5	127
Width Increments	1.00	25.4
Opening Sizes (approx.)	0.62 × 0.50	15.7 × 12.7
	0.70 × 0.26	17.8 × 6.6
Open Area	37%	
Hinge Style	Closed	
Drive Method	Center/Hinge-Driven	

Product Notes

- **Contact Intralox for precise belt measurements and stock status before designing equipment or ordering a belt.**
- Fully flush edges with highly visible, orange acetal Slidex® rod retention feature.
- Uses headless rods.
- Robust design offers excellent belt and sprocket durability, especially in tough material handling applications.
- Abrasion resistant system lasts 2.5 to 3 times longer than conventional modular plastic belts.
- Sprockets have large lug teeth.
- Multi-rod hinge design significantly reduces cam shafting. Every row contains two rectangular rods.
- Abrasion resistant nylon used in modules and rods.
- Ultra abrasion resistant polyurethane sprockets.
- Steel is preferred carryway material.
- Chevron pattern or flat continuous carryway recommended. Straight, parallel wearstrips should not be used. Do not use on pusher conveyors.

Additional Information

- See “Belt Selection Process” (page 5)
- See “Standard Belt Materials” (page 9)
- See “Special Application Belt Materials” (page 9)
- See “Friction Factors” (page 13)

Belt Data							
Belt Material	Standard Rod Material 0.25 × 0.17 in (6.4 × 4.3 mm)	BS Belt Strength		Temperature Range (continuous) ^a		W Belt Weight	
		lb/ft	kg/m	°F	°C	lb/ft ²	kg/m ²
AR Nylon	Nylon	1800	2678	-50 to 240	-46 to 116	2.21	10.78
Detectable Nylon	Nylon	1500	2232	-50 to 180	-46 to 82	2.28	11.13
Low Wear Plus	Nylon	500	744	0 to 120	-18 to 49	2.56	12.50

a. Sprocket temperatures should be limited to -40 to 160 °F (-40 to 70 °C). Belt used in temperature range of 212 to 240 °F (100 to 116 °C) are not FDA-compliant.

Flush Grid Nub Top™

	in	mm
Pitch	1.50	38.1
Minimum Width	16	406.4
Width Increments	1.00	25.4
Opening Sizes (approx.)	0.70 × 0.26	18 × 7
Open Area	37%	
Product Contact Area	8%	
Hinge Style	Closed	
Drive Method	Center/Hinge-Driven	

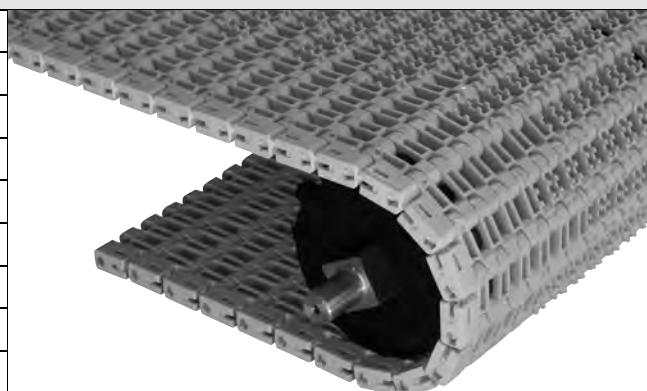

Product Notes

- **Contact Intralox for precise belt measurements and stock status before designing equipment or ordering a belt.**
- Fully flush edges with highly visible, orange acetal Slidelox® rod retention feature.
- Uses headless rods.
- Robust design offers excellent belt and sprocket durability, especially in tough material handling applications.
- Abrasion resistant system lasts 2.5 to 3 times longer than conventional modular plastic belts.
- Sprockets have large lug teeth.
- Multi-rod hinge design significantly reduces cam shafting. Every row contains two rectangular rods.
- Abrasion resistant nylon used in modules and rods.
- Ultra abrasion resistant polyurethane split sprockets.
- Steel is preferred carryway material.
- Chevron pattern or flat continuous carryway recommended. Do not use straight, parallel wearstrips.
- Do not use on pusher conveyors.
- Minimum nominal alternating edge indents of 4 in (102 mm) and 6 in (152 mm).

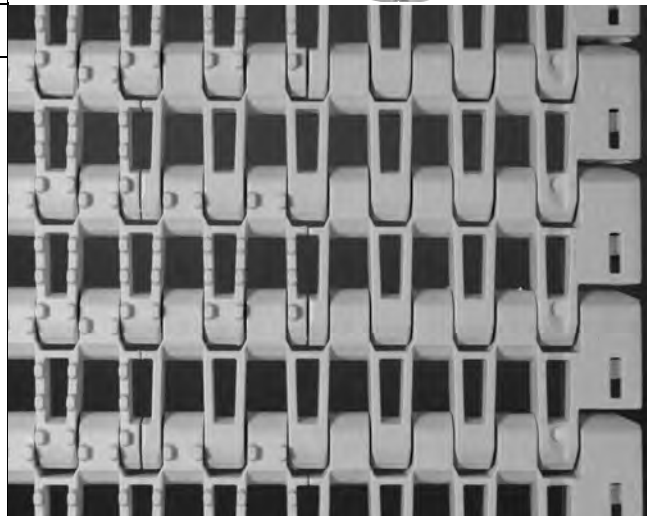

Additional Information

- See "Belt Selection Process" (page 5)
- See "Standard Belt Materials" (page 9)
- See "Special Application Belt Materials" (page 9)
- See "Friction Factors" (page 13)

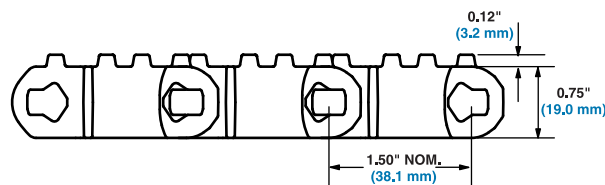

Belt Data

Belt Material	Standard Rod Material 0.25 × 0.17 in (6.4 × 4.3 mm)	BS Belt Strength		Temperature Range (continuous) ^a		W Belt Weight	
		lb/ft	kg/m	°F	°C	lb/ft ²	kg/m ²
AR Nylon	Nylon	1800	2678	-50 to 240	-46 to 116	2.21	10.78
Easy Release Traceable PP	Nylon	1500	2230	34 to 220	1 to 104	1.84	8.98
Low Wear Plus	Low Wear Plus	500	744	0 to 120	-18 to 49	2.58	12.60

a. Sprocket temperatures should be limited to -40 to 160 °F (-40 to 70 °C). Belt used in temperature range of -212 to 240 °F (100 to 116 °C) are not FDA-compliant.

Transverse Roller Top™		
	in	mm
Pitch	1.475	37.5
Minimum Width	12	304.8
Width Increments	2.00 ^a	50.8
Min. Opening Size (approx.)	0.62 x 0.50	16 x 13
Max. Opening Size (approx.)	0.70 x 0.26	18 x 7
Open Area	26%	
Hinge Style	Closed	
Drive Method	Center/Hinge-Driven	
Product Notes		
<ul style="list-style-type: none"> • Contact Intralox for precise belt measurements and stock status before designing equipment or ordering a belt. • Robust design offers excellent belt and sprocket durability, especially in tough, material handling applications. • Uses headless rods. • Sprockets have large lug teeth. • Ultra abrasion resistant polyurethane sprockets. • Split sprockets are available. • Roller axles are stainless steel for durability and long-lasting performance. • Roller diameter is 0.95 in (24.1 mm). • Roller length is 0.825 in (21 mm). • Roller spacing is 1.0 in (25.4 mm). • Minimum return roller diameter is 6.0 in (152.4 mm). • Must be assembled in 2-row increments. 		
Additional Information		
<ul style="list-style-type: none"> • See “Belt Selection Process” (page 5) • See “Standard Belt Materials” (page 9) • See “Special Application Belt Materials” (page 9) • See “Friction Factors” (page 13) 		

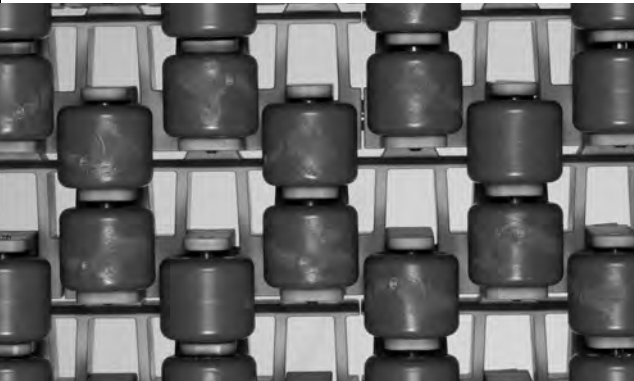
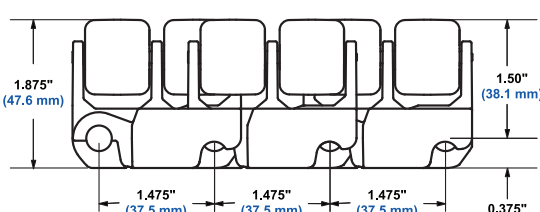
a. Available in width increments of 2 in (50.8 mm) except 14 in (356 mm) wide belt not available.

Belt Data							
Belt Material	Standard Rod Material Ø 0.312 in (7.9 mm)	BS Belt Strength		Temperature Range (continuous)		W Belt Weight	
		lb/ft	kg/m	°F	°C	lb/ft ²	kg/m ²
Polypropylene	Nylon	2200	3270	34 to 200	1 to 93	4.70	22.96

Sprocket and Support Quantity Reference Flush Grid and Flush Grid Nub Top™

Belt Width Range ^a		Minimum Number of Sprockets Per Shaft ^b	Wearstrips	
in.	mm		Carryway	Returnway
5	127	2	Straight, parallel wearstrips should not be used. Use chevron pattern or flat continuous carryway instead.	Straight, parallel wearstrips should not be used. Use chevron pattern or flat continuous carryway instead.
6	152	2		
7	178	3		
8	203	3		
9	229	3		
10	254	3		
12	305	3		
14	356	3		
15	381	3		
16	406	5		
18	457	5		
20	508	5		
24	610	5		
30	762	7		
32	813	9		
36	914	11		
42	1067	13		
48	1219	15		
54	1372	17		
60	1524	19		
72	1829	23		
84	2134	27		
96	2438	31		
120	3048	39		
144	3658	47		
For Other Widths, Use Odd Number of Sprockets ^{cd} at Maximum 4 in. (102 mm) \varnothing Spacing			Maximum 6 in. (152 mm) \varnothing Spacing	Maximum 12 in. (305 mm) \varnothing Spacing

- a. Belts are available in 1.00 in. (25.4 mm) increments beginning with 5 in. (127 mm). If the actual width is critical, consult Customer Service.
- b. These are the minimum number of sprockets. Additional sprockets may be required for heavily loaded applications.
- c. The center sprocket should be locked down. With only two sprockets, fix the sprocket on the drive journal side only. See Retainer Rings/Center Sprocket Offset chart on page 410 for lock down location.
- d. For Drive shaft, use an odd number of sprockets at maximum of 3.00 in. (76.2 mm) center line spacing.

Sprocket and Support Quantity Reference Transverse Roller Top™

Belt Width Range ^a		Minimum Number of Sprockets Per Shaft ^b	Wearstrips	
in.	mm		Carryway	Returnway
5	127	2	2	2
6	152	2	2	2
7	178	3	2	2
8	203	3	2	2
9	229	3	3	2
10	254	3	3	2
12	305	3	3	2
14	356	3	3	3
15	381	3	3	3
16	406	5	3	3
18	457	5	3	3
For Other Widths, Use Odd Number of Sprockets ^c at Maximum 4 in. (102 mm) \varnothing Spacing			Maximum 6 in. (152 mm) \varnothing Spacing	Maximum 12 in. (305 mm) \varnothing Spacing

Sprocket and Support Quantity Reference Transverse Roller Top™					
Belt Width Range ^a		Minimum Number of Sprockets Per Shaft ^b	Wearstrips		
in.	mm		Carryway		Returnway
20	508	5	4		3
24	610	5	4		3
30	762	7	5		4
32	813	7	5		4
36	914	9	5		4
42	1067	9	6		5
48	1219	11	7		5
54	1372	11	7		6
60	1524	13	8		6
72	1829	15	9		7
84	2134	17	11		8
96	2438	21	12		9
120	3048	25	15		11
144	3658	29	17		13
For Other Widths, Use Odd Number of Sprockets ^c at Maximum 4 in. (102 mm) \varnothing Spacing			Maximum 6 in. (152 mm) \varnothing Spacing		Maximum 12 in. (305 mm) \varnothing Spacing

- a. Belts are available in 1.00 in. (25.4 mm) increments beginning with 5 in. (127 mm). If the actual width is critical, consult Customer Service.
- b. These are the minimum number of sprockets. Additional sprockets may be required for heavily loaded applications.
- c. The center sprocket should be locked down. With only two sprockets, fix the sprocket on the drive journal side only. See Retainer Rings/Center Sprocket Offset chart on page 410 for lock down location.

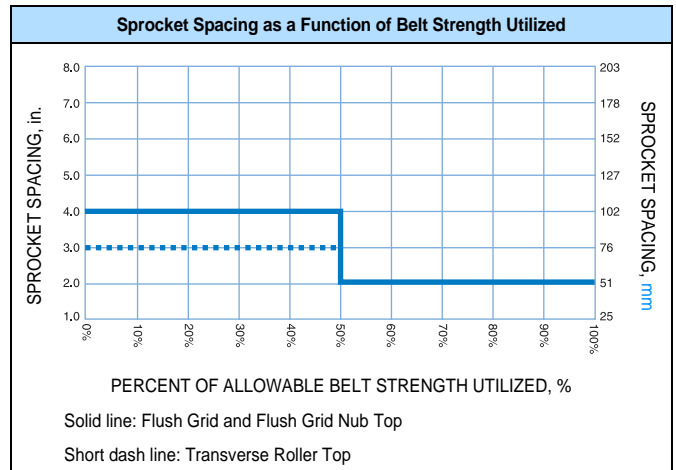
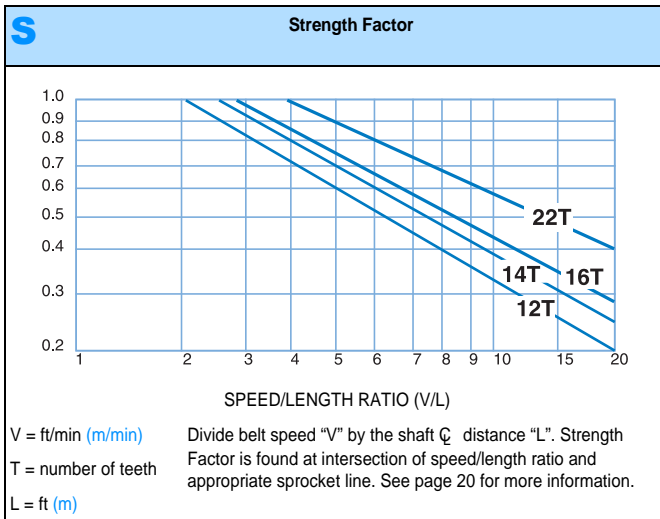

Ultra Abrasion Resistant Polyurethane Sprockets^a										
No. of Teeth (Chordal Action)	Nom. Pitch Dia. in	Nom. Pitch Dia. mm	Nom. Outer Dia. in	Nom. Outer Dia. mm	Nom. Hub Width in	Nom. Hub Width mm	Available Bore Sizes			
							U.S. Sizes		Metric Sizes	
							Round in	Square in	Round mm	Square mm
12 (3.41%)	5.8	147	5.85	149	1.5	38	1.5		40	
14 (2.51%)	6.7	170	6.80	173	1.5	38	1.5		40	
16 (1.92%)	7.7	196	7.74	197	1.5	38	1.5		40	
							2.5		60	
22 (1.02%)	10.5	267	10.59	269	1.5	38	2.5			

a. Contact Customer Service for lead times.

Ultra Abrasion Resistant Polyurethane Split Sprockets

No. of Teeth (Chordal Action)	Nom. Pitch Dia. in	Nom. Pitch Dia. mm	Nom. Outer Dia. in	Nom. Outer Dia. mm	Nom. Hub Width in	Nom. Hub Width mm	Available Bore Sizes			
							U.S. Sizes		Metric Sizes	
							Round in	Square in	Round mm	Square mm
14 (2.51%)	6.7	170	6.80	173	1.5	38		1.5		40
								2.5		60
16 (1.92%)	7.7	196	7.74	197	1.5	38		1.5		40
								2.5		60
22 (1.02%)	10.5	267	10.59	269	1.5	38		2.5		60
								3.5		



Streamline Flights

Available Flight Height		Available Materials
in	mm	
4.0	102	Nylon (AR) Detectable Nylon
6.0	152	

Note: Minimum indent is 2.0 in (51 mm)

Note: Flights can be cut down to custom heights with a minimum height of 0.25 in (13 mm).

Note: Flight is smooth (streamline) on both sides.

Note: Each flight rises out of the center of its supporting module, molded as an integral part. No fasteners are required.

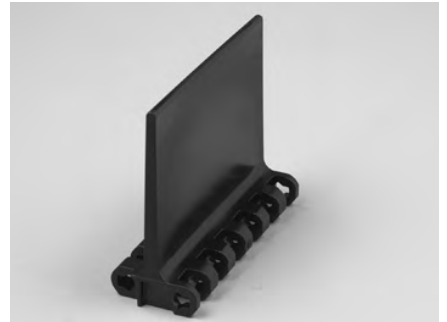

Conveyor Frame Dimensions

Regardless of type or configuration, all conveyors using Intralox belts have some basic dimensional requirements. Specifically, dimensions "A", "B", "C" and "E" listed below should be implemented in any design.

For general applications and applications where end transfer of tip-sensitive product is not critical, use the "A" dimension at the bottom of the range.

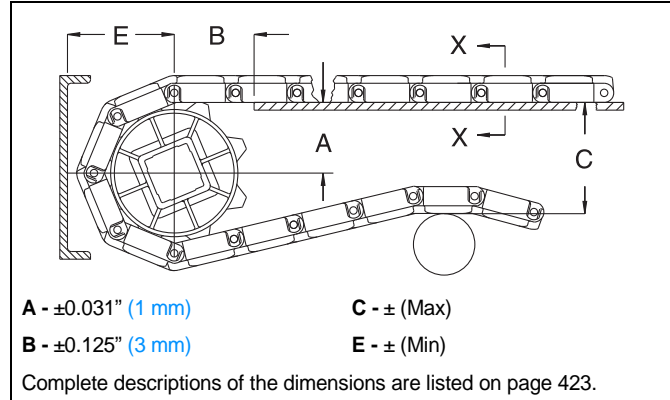

Sprocket Description		A		B		C		E		
Pitch Diameter		No. Teeth	Range (Bottom to Top)		in.	mm	in.	mm	in.	mm
in.	mm		in.	mm						
SERIES 1700 FLUSH GRID										
5.8	147	12	2.36-2.46	60-62	2.42	61	5.67	144	3.27	83
6.7	170	14	2.85-2.93	72-74	2.63	67	6.61	168	3.74	95
7.7	196	16	3.33-3.40	85-86	2.81	71	7.56	192	4.22	107
10.5	267	22	4.78-4.83	121-123	3.30	84	10.41	264	5.64	143
SERIES 1700 FLUSH GRID NUB TOP										
5.8	147	12	2.36-2.46	60-62	2.42	61	5.79	147	3.39	86
6.7	170	14	2.85-2.93	72-74	2.63	67	6.73	171	3.86	98
7.7	196	16	3.33-3.40	85-86	2.81	71	7.68	195	4.34	110
10.5	267	22	4.78-4.83	121-123	3.30	84	10.53	267	5.76	146
SERIES 1700 TRANSVERSE ROLLER TOP										
5.8	147	12	2.42-2.52	61-64	2.36	60	6.92	176	4.46	113
6.7	170	14	2.91-3.00	74-76	2.56	65	7.87	200	4.93	125
7.7	196	16	3.40-3.47	86-88	2.73	69	8.81	224	5.41	137
10.5	267	22	4.84-4.90	123-124	3.20	81	11.67	296	6.83	173

Dead Plate Gap

Where there is a transfer point from a belt without finger transfer plates to a dead plate, there should be a gap between the surfaces to allow for the chordal action of the belt. As the belt engages its sprockets, chordal action causes the modules to move past a *fixed* point (the tip of the dead plate) with *varying* clearances. The table below shows the minimum amount of gap which occurs at the “low point” of the modules if the tip of the dead plate just comes in contact with the “high point” as the modules pass.

In some installations it may be desirable to keep the tip of the dead plate in contact with the belt, rather than allow a gap to occur. This can be done by hinging the mounting bracket for the dead plate. This allows the dead plate to move as the modules pass, but results in a small oscillating motion which may present tippage problems for sensitive containers or products.

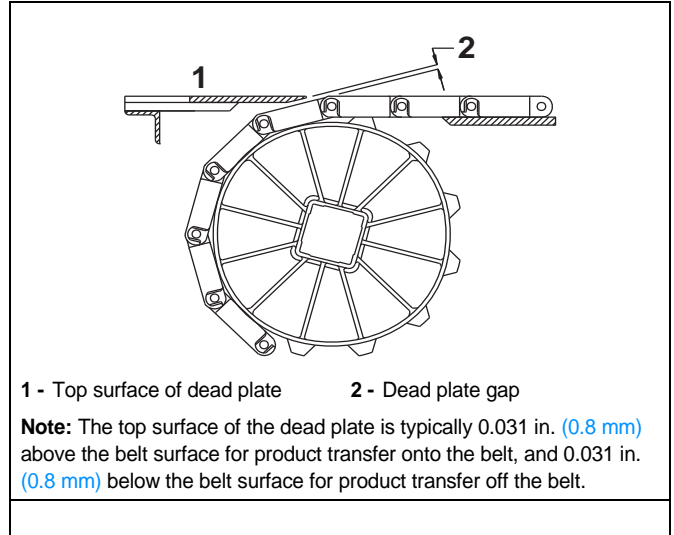

Sprocket Description		Gap		
Pitch Diameter		No. Teeth		
in.	mm		in.	mm
5.8	147	12	0.099	2.5
6.7	170	14	0.085	2.2
7.7	196	16	0.074	1.9
10.5	267	22	0.054	1.4

Flush Grid		
	in	mm
Pitch	1.52	38.6
Minimum Width	12	304.8
Maximum Width	120	3048
Width Increments	1.00	25.4
Opening Sizes (approx.)	0.66 x 0.53	16.7 x 13.5
Open Area	21%	
Hinge Style	Closed	
Drive Method	Center/Hinge-Driven	
Product Notes		
<ul style="list-style-type: none"> • Contact Intralox for precise belt measurements and stock status before designing equipment or ordering a belt. • Fully flush edges with highly visible Slidex® rod retention feature. • Uses headless rods. • Robust design offers excellent belt and sprocket durability, especially in tough material handling applications. • Semi-circle rod design significantly reduces rod wear and pitch elongation, delivering predictable performance for maintenance planning in tough applications. • Ultra abrasion resistant polyurethane sprockets. • Sprockets have large lug teeth that provide reliable engagement, extend sprocket life, and clear debris from the drive pockets. • Large belt openings for high volume water flow and drainage. • Stainless steel is the preferred carryway material. • Chevron pattern or flat continuous carryway recommended. Do not use straight, parallel wearstrips. Do not use on pusher conveyors. • For specific S1750 Design Guidelines, contact the Technical Support Group. 		
Additional Information		
<ul style="list-style-type: none"> • See "Belt Selection Process" (page 5) • See "Standard Belt Materials" (page 9) • See "Special Application Belt Materials" (page 9) • See "Friction Factors" (page 13) 		

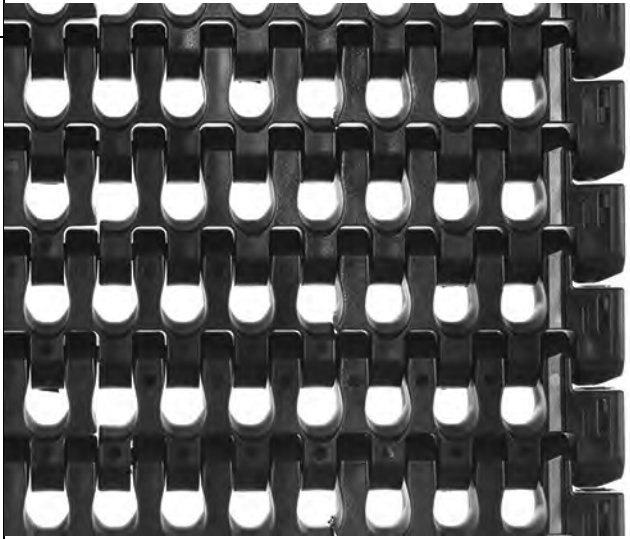
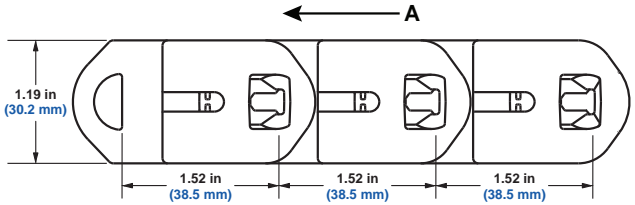
Belt Data							
Belt Material	Standard Rod Material 0.25 x 0.17 in (6.4 x 4.3 mm)	BS Belt Strength		Temperature Range (continuous)		W Belt Weight	
		lb/ft	kg/m	°F	°C	lb/ft²	kg/m²
Low Wear Plus	Stainless Steel	1200	1790	0 to 120	-18 to 49	7.10	34.66
Low Moisture Abrasion Resistant	Stainless Steel	1800	2680	0 to 212	-18 to 100	6.73	32.86

Sprocket and Support Quantity Reference Flush Grid				
Belt Width Range ^a		Minimum Number of Sprockets Per Shaft ^b	Wearstrips	
in	mm		Carryway	Returnway
12-14	305-356	5	Only use a chevron pattern or flat continuous carryway. Do not use straight, parallel wearstrips.	Only use a chevron pattern or flat continuous carryway. Do not use straight, parallel wearstrips.
15-18	381-457	7		
20	508	9		
24	610	11		
30	762	13		
32	813	15		
36	914	17		
42	1067	19		
48	1219	23		
54	1372	25		
60	1524	29		
72	1829	35		
84	2134	41		
96	2438	47		
108	2743	53		
120	3038	59		
For Other Widths, Use Odd Number of Sprockets ^{cd} at Maximum 2 in (51 mm) \varnothing Spacing				

- a. Belts are available in 1.00 in (25.4 mm) increments beginning with 12 in (305 mm). **If the actual width is critical, contact Customer Service.**
- b. These are the minimum number of sprockets. Additional sprockets may be required for heavily loaded applications.
- c. The center sprocket should be locked down. With only two sprockets, fix the sprocket on the drive journal side only.
- d. For drive shaft, use an odd number of sprockets at maximum of 2.00 in (50.8 mm) centerline spacing.

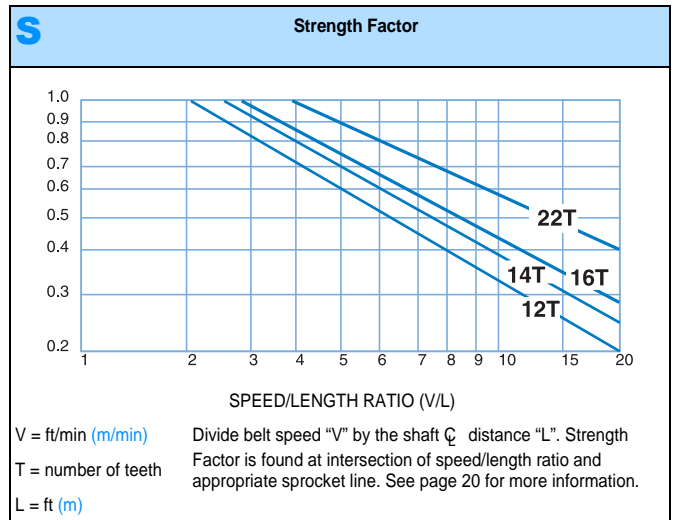
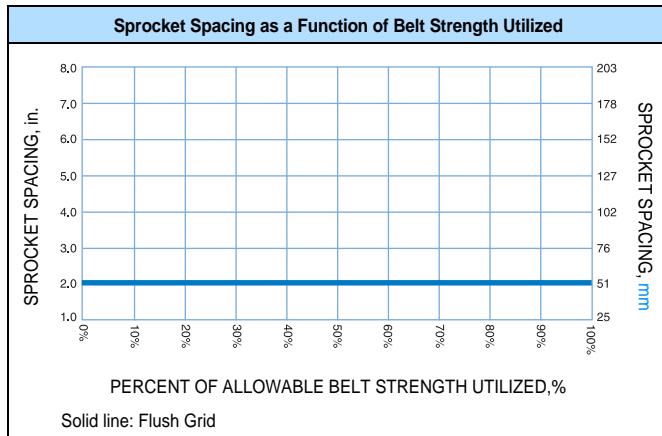

Ultra Abrasion Resistant Polyurethane Sprocket ^a										
No. of Teeth (Chordal Action)	Nom. Pitch Dia. in	Nom. Pitch Dia. mm	Nom. Outer Dia. in	Nom. Outer Dia. mm	Nom. Hub Width in	Nom. Hub Width mm	Available Bore Sizes			
							U.S. Sizes		Metric Sizes	
							Round in	Square in	Round mm	Square mm
16 (1.92%)	7.8	198	7.9	201	1.5	38		2.5		60
22 (1.02%)	10.6	269	10.9	277	1.5	38		2.5 3.5		60



a. Contact Customer Service for lead times.

Ultra Abrasion Resistant Split Sprocket Data ^a										
No. of Teeth (Chordal Action)	Nom. Pitch Dia. in	Nom. Pitch Dia. mm	Nom. Outer Dia. in	Nom. Outer Dia. mm	Nom. Hub Width in	Nom. Hub Width mm	Available Bore Sizes			
							U.S. Sizes		Metric Sizes	
							Round in	Square in	Round mm	Square mm
14 (2.51%)	6.8	173	6.9	175	1.5	38	1.5 2.5			40 60
16 (1.92%)	7.8	198	7.9	201	1.5	38	1.5 2.5			40 60
22 (1.02%)	10.6	269	10.9	277	1.5	38	2.5 3.5			60



a. Contact Customer Service for lead times.

3-Piece Streamline Flights		
Available Flight Height		Available Materials
in	mm	
3.0	76	Low Wear Plus, Low Moisture Abrasion Resistant
4.0	102	

Note: Flight consists of 3 pieces: the base module, the attachment, and the rod.
Note: Available with zero indent. The first available indent is 1.625 in (41 mm). Contact Intralox Customer Service for valid indent increments.
Note: Flights can be cut as short as 1.5 in (38 mm) if necessary for a particular application. If a shorter flight is needed, the flight base module without a flight attachment functions as a 0.75 in (19 mm) raised link. Contact Intralox Customer Service for more information.
Note: Flight is smooth (streamline) on both sides.



Urethane Wearstrip		
Dimensions		Available Colors
in	mm	
0.50 x 2 x 216	13 x 51 x 5486	Blue

Note: Temperature range is 32°F (0°C) to 120°F (49°C).
Note: Contact Intralox Customer Service for friction and belt strength analysis.
Note: intended for belting applications with all dry, aqueous, and solid fatty foods (not liquid oils).



Conveyor Frame Dimensions

Regardless of type or configuration, all conveyors using Intralox belts have some basic dimensional requirements. Specifically, implement dimensions “A”, “B”, “C” and “E” listed in the following table in any design.

For general applications and applications where end transfer of tip-sensitive product is not critical, use the “A” dimension at the bottom of the range.

Conveyor frame dimensions are established using the top of the roller as the top of the belt and the bottom of the module as the bottom of the belt. “B” dimension is based on a 0.5 in (12.7 mm) thick carryway.

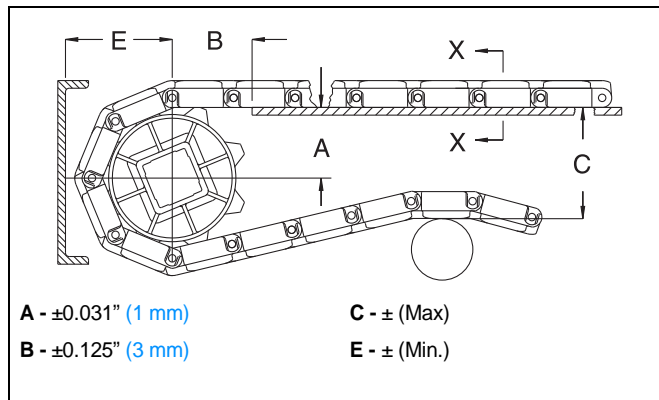

Sprocket Description		A		B		C		E		
Pitch Diameter		No. Teeth	Range (Bottom to Top)		in	mm	in	mm	in	mm
in	mm		in	mm						
FLUSH GRID										
6.8	173	14	2.72-2.81	69-71	2.83	72	6.81	173	4.06	103
7.8	198	16	3.21-3.29	82-84	3.04	77	7.77	197	4.54	115
10.6	269	22	4.67-4.73	119-120	3.68	93	10.65	271	5.98	152

Dead Plate Gap

Where there is a transfer point from a belt without finger transfer plates to a dead plate, there should be a gap between the surfaces to allow for the chordal action of the belt. As the belt engages its sprockets, chordal action causes the modules to move past a *fixed* point (the tip of the dead plate) with *varying* clearances. The following table shows the minimum amount of gap which occurs at the “low point” of the modules if the tip of the dead plate just comes in contact with the “high point” as the modules pass.

In some installations, it may be desirable to keep the tip of the dead plate in contact with the belt, rather than allow a gap to occur. This can be done by hinging the mounting bracket for the dead plate. This allows the dead plate to move as the modules pass, but results in a small oscillating motion which may present tipping problems for sensitive containers or products.

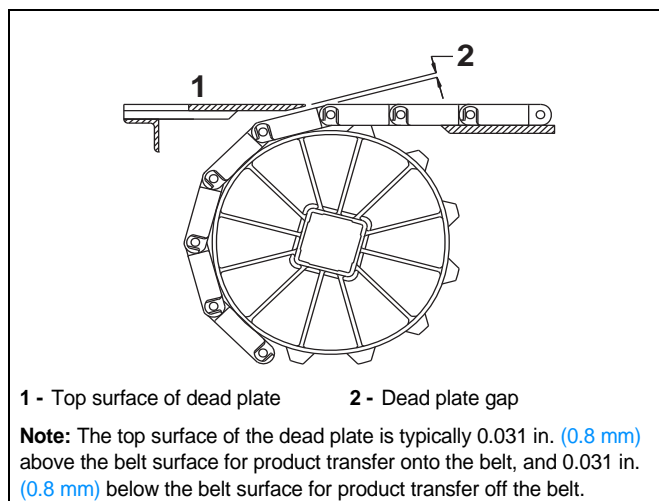

Sprocket Description			Gap	
Pitch Diameter		No. Teeth	in	mm
in	mm			
6.8	173	14	0.085	2.2
7.8	198	16	0.075	1.9
10.6	269	22	0.054	1.4

Flat Top		
	in	mm
Pitch	2.50	63.5
Minimum Width	5	127
Width Increments	1.00	25.4
Opening Size (approximate)	-	-
Open Area	0%	
Hinge Style	Open	
Drive Method	Center-driven	

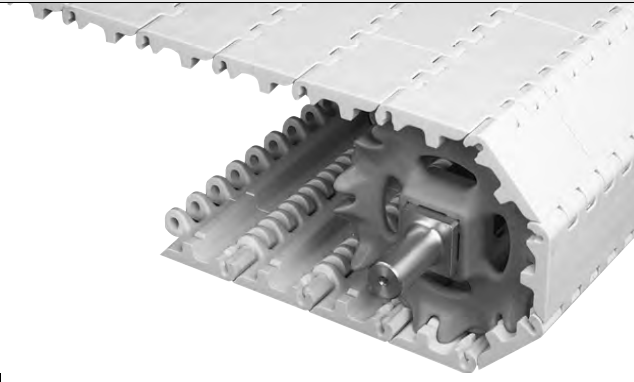

Product Notes

- **Contact Intralox for precise belt measurements and stock status before designing equipment or ordering a belt.**
- Smooth, closed upper surface with fully flush edges.
- Uses headless rods.
- Impact resistant belt designed for abusive applications.
- Easy retrofit from Series 800 without extensive conveyor frame changes for most meat industry applications since the A,B,C,E dimensions are within 1/4 in (6 mm) of Series 800.
- Cam-link designed hinges - expose more hinge and rod area as belt goes around the sprocket. This exclusive Intralox feature allows unsurpassed cleaning access to this area.
- Like Series 800 and Series 1600, the drive bar on the underside of S1800 Flat Top channels water and debris to the outside of the belt for easier, faster cleanup. The drive bar's effectiveness has been proven both in-house and in field tests.

Additional Information

- See "Belt Selection Process" (page 5)
- See "Standard Belt Materials" (page 9)
- See "Special Application Belt Materials" (page 9)
- See "Friction Factors" (page 13)

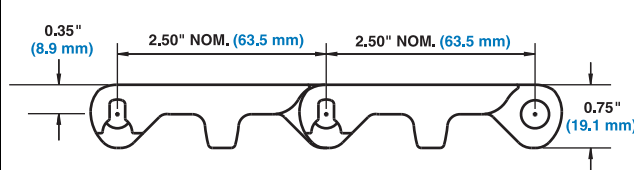

SECTION 2

1800

Belt Data							
Belt Material	Standard Rod Material Ø 0.312 in (7.9 mm)	BS		Temperature Range (continuous)		W	
		Belt Strength		°F	°C	Belt Weight	
		lb/ft	kg/m			lb/ft ²	kg/m ²
Polypropylene	Polypropylene	1200	1786	34 to 220	1 to 104	2.06	10.06
Polyethylene	Polyethylene	700	1042	-50 to 150	-46 to 66	2.23	10.90
Acetal	Polyethylene	1200	1786	-50 to 150	-46 to 66	3.36	16.40
Acetal	Polypropylene	1500	2232	34 to 200	1 to 93	3.36	16.40
X-Ray Detectable Acetal ^a	Polyethylene	1000	1490	-50 to 150	-46 to 66	3.77	18.41

a. Designed specifically to be detected by x-ray machines.

Mesh Top™

	in	mm
Pitch	2.50	63.5
Minimum Width	5	127
Width Increments	1.00	25.4
Opening Size (approximate)	0.07 × 0.75	1.7 × 19.1
Open Area	32%	
Hinge Style	Open	
Drive Method	Center-driven	



Product Notes

- **Contact Intralox for precise belt measurements and stock status before designing equipment or ordering a belt.**
- Fully flush edges with recessed rods prevent edge damage and rod migration.
- Uses headless rods.
- Available with flights and other Series 1800 accessories.

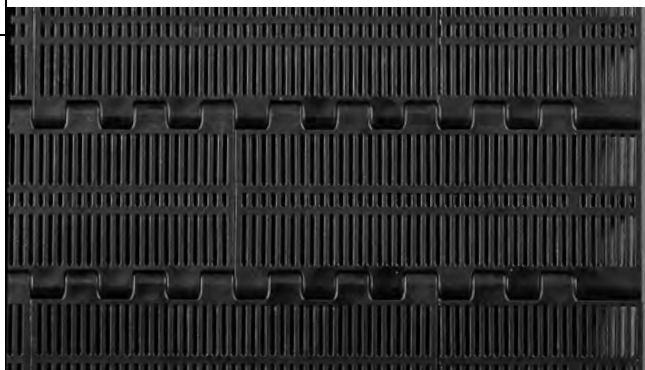

Additional Information

- See "Belt Selection Process" (page 5)
- See "Standard Belt Materials" (page 9)
- See "Special Application Belt Materials" (page 9)
- See "Friction Factors" (page 13)

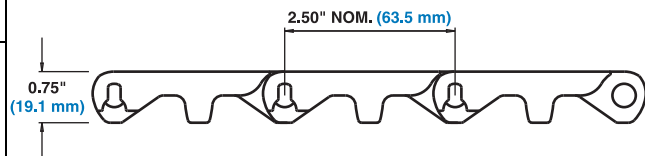

Belt Data

Belt Material	Standard Rod Material Ø 0.312 in (7.9 mm)	BS		Temperature Range (continuous)		W	
		Belt Strength		°F	°C	Belt Weight	
		lb/ft	kg/m			lb/ft ²	kg/m ²
Polypropylene	Polypropylene	800	1190	34 to 220	1 to 104	1.44	7.03
UV Resistant PP	Acetal	1100	1640	34 to 200	1 to 93	1.55	7.56
UV Resistant Acetal	Acetal	1500	2230	-50 to 200	-46 to 93	2.27	11.08
Polyethylene	Polyethylene	400	595	-50 to 150	-46 to 66	1.50	7.32
Nylon	Nylon	1000	1488	-50 to 240	-46 to 116	1.81	8.84

Sprocket and Support Quantity Reference				
Belt Width Range ^a		Minimum Number of Sprockets Per Shaft ^b	Wearstrips	
in.	mm		Carryway	Returnway
5	127	1	2	2
6	152	2	2	2
7	178	2	2	2
8	203	2	2	2
9	229	2	2	2
10	254	2	3	2
12	305	3	3	2
14	356	3	3	3
15	381	3	3	3
16	406	3	3	3
18	457	3	3	3
20	508	3	4	3
24	610	5	4	3
30	762	5	5	4
32	813	5	5	4
36	914	7	5	4
42	1067	7	6	5
48	1219	9	7	5
54	1372	9	7	6
60	1524	11	8	6
72	1829	13	9	7
84	2134	15	11	8
96	2438	17	12	9
For Other Widths, Use Odd Number of Sprockets ^c at Maximum 6 in. (152 mm) \varnothing Spacing			Maximum 9 in. (229 mm) \varnothing Spacing	Maximum 12 in. (305 mm) \varnothing Spacing

- If your belt width exceeds a number listed in the table, please refer to the sprocket and support material minimums for the next larger width range listed. Belts are available in 1.00 in. (25.4 mm) increments beginning with 5.0 in. (127 mm). **If the actual width is critical, consult Customer Service.**
- These are the minimum number of sprockets. Additional sprockets may be required for heavily loaded applications.
- The center sprocket should be locked down. With only two sprockets, fix the sprocket on the drive journal side only. See Retainer Rings/Center Sprocket Offset chart on page 410 for lock down location.

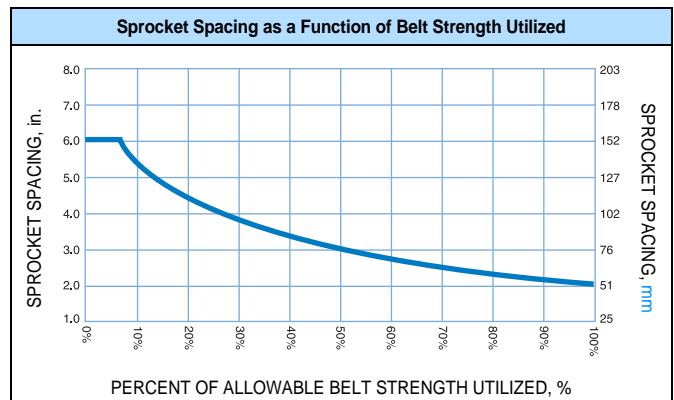
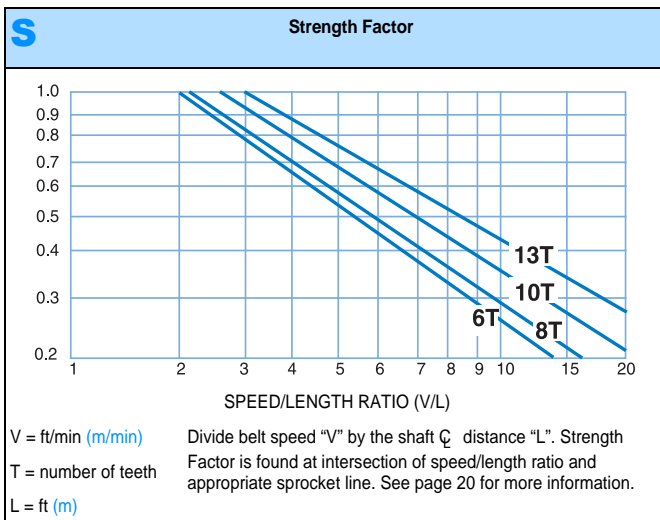

EZ Clean Sprocket ^a										
No. of Teeth (Chordal Action)	Nom. Pitch Dia. in.	Nom. Pitch Dia. mm	Nom. Outer Dia. in.	Nom. Outer Dia. mm	Nom. Hub Width in.	Nom. Hub Width mm	Available Bore Sizes			
							U.S. Sizes		Metric Sizes	
							Round in.	Square in.	Round mm	Square mm
6 (13.40%)	5.0	127	4.6	117	1.5	38		1.5		40
8 (7.61%)	6.5	165	6.2	157	1.5	38		1.5		40
10 (4.89%)	8.1	206	7.8	198	1.5	38		1.5		40
13 (2.91%)	10.5	267	10.3	262	1.5	38		1.5		40
								2.5		60

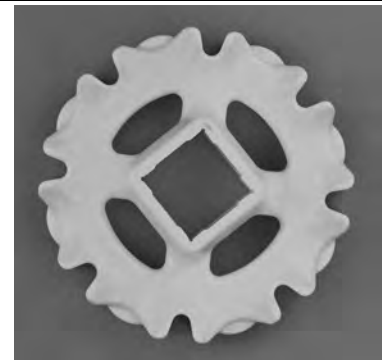

a. Contact Customer Service for lead times.

Angled EZ Clean Sprocket ^a										
No. of Teeth (Chordal Action)	Nom. Pitch Dia. in.	Nom. Pitch Dia. mm	Nom. Outer Dia. in.	Nom. Outer Dia. mm	Nom. Hub Width in.	Nom. Hub Width mm	Available Bore Sizes			
							U.S. Sizes		Metric Sizes	
							Round in.	Square in.	Round mm	Square mm
8 (7.61%)	6.5	165	6.2	157	2.0	50.8		1.5		40

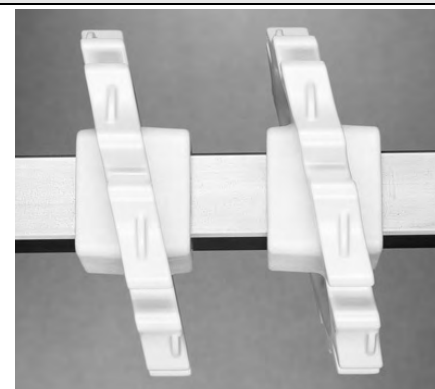

a. Contact Customer Service for lead times.

Impact Resistant Flights		
Available Flight Height		Available Materials
in.	mm	
4.0	102	Polypropylene, Polyethylene, Acetal, X-Ray Detectable Acetal
<p>Note: Flights can be cut down to custom heights with a minimum height of 0.25 in (13 mm).</p> <p>Note: Each flight rises out of the center of its supporting module, molded as an integral part. No fasteners are required.</p>		

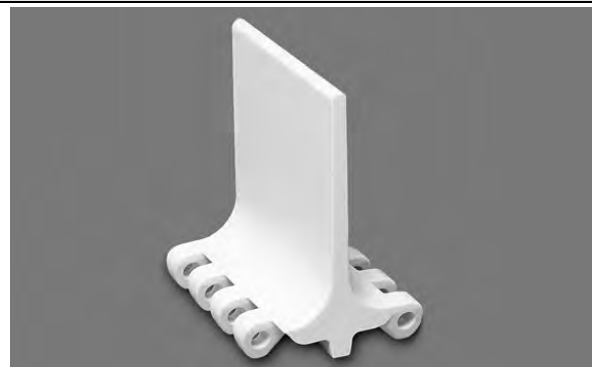

Conveyor Frame Dimensions

Regardless of type or configuration, all conveyors using Intralox belts have some basic dimensional requirements. Specifically, dimensions “A”, “B”, “C” and “E” listed below should be implemented in any design.

For general applications and applications where end transfer of tip-sensitive product is not critical, use the “A” dimension at the bottom of the range.

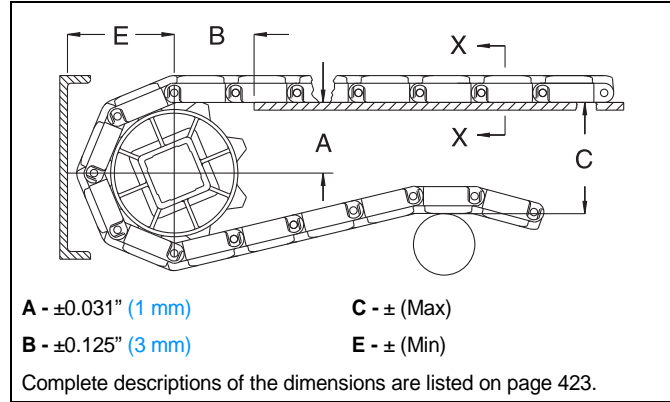

Sprocket Description		A		B		C		E		
Pitch Diameter		No. Teeth	Range (Bottom to Top)		in.	mm	in.	mm	in.	mm
in.	mm		in.	mm						
SERIES 1800 FLAT TOP, MESH TOP										
5.0	127	6	1.77-2.10	45-53	1.87	47	4.95	126	2.91	74
6.5	165	8	2.62-2.87	66-73	2.23	57	6.48	165	3.68	93
8.1	206	10	3.45-3.65	88-93	2.59	66	8.04	204	4.46	113
10.5	267	13	4.67-4.82	119-123	3.02	77	10.40	264	5.64	143

Dead Plate Gap

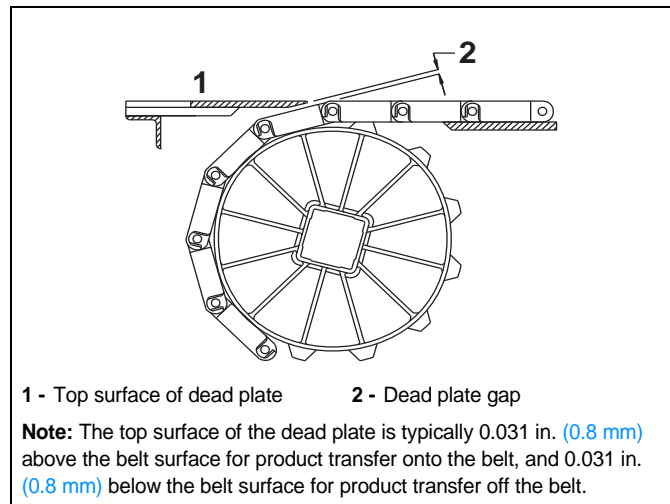

Where there is a transfer point from a belt without finger transfer plates to a dead plate, there should be a gap between the surfaces to allow for the chordal action of the belt. As the belt engages its sprockets, chordal action causes the modules to move past a *fixed* point (the tip of the dead plate) with *varying* clearances. The table below shows the minimum amount of gap which occurs at the “low point” of the modules if the tip of the dead plate just comes in contact with the “high point” as the modules pass.

In some installations it may be desirable to keep the tip of the dead plate in contact with the belt, rather than allow a gap to occur. This can be done by hinging the mounting bracket for the dead plate. This allows the dead plate to move as the modules pass, but results in a small oscillating motion which may present tippage problems for sensitive containers or products.

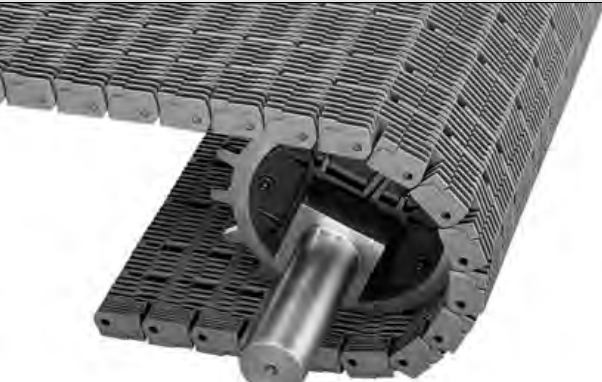

Sprocket Description			Gap	
Pitch Diameter		No. Teeth	in.	mm
in.	mm			
5.0	127	6	0.150	3.8
6.5	165	8	0.108	2.8
8.1	206	10	0.091	2.3
10.5	267	13	0.074	1.9

Raised Rib		
	in	mm
Pitch	2.07	52.6
Minimum Width	15	381
Width Increments	1.00	25.4
Opening Sizes (approx.)	-	-
Open Area	27%	
Hinge Style	Closed	
Drive Method	Center/Hinge-Driven	
Product Notes		
<ul style="list-style-type: none"> • Contact Intralox for precise belt measurements and stock status before designing equipment or ordering a belt. • Increased module thickness and rod diameter provide superior belt strength and increases belt life. • Shuttleplug™ self-closing rod retention system. • Uses headless rods. • Split sprockets available for easy installation. • Made of engineered resin for increased resistance to chemicals and temperature cycling. • Minimal back tension required. • More robust transfers utilize taller belt ribs and stronger fingers. 		
Additional Information		
<ul style="list-style-type: none"> • See "Belt Selection Process" (page 5) • See "Standard Belt Materials" (page 9) • See "Special Application Belt Materials" (page 9) • See "Friction Factors" (page 13) 		

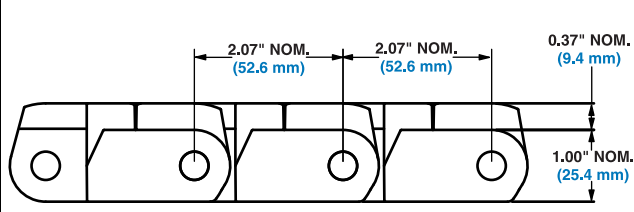
Belt Data									
Belt Material	Standard Rod Material 0.38 (9.7 mm)	BS	Belt Strength		Temperature Range (continuous)		W	Belt Weight	
			lb/ft	kg/m	°F	°C		lb/ft²	kg/m²
Enduralox™ Polypropylene	Polypropylene	4000	5952	34 to 220	1 to 104	3.90	19.04		

Sprocket and Support Quantity Reference				
Belt Width Range ^a		Minimum Number of Sprockets Per Shaft ^b	Wearstrips	
in.	mm		Carryway	Returnway
15	381	3	3	3
18	457	3	3	3
24	610	5	4	3
30	762	5	5	4
36	914	7	5	4
42	1067	7	6	5
48	1219	9	7	5
54	1372	9	7	6
60	1524	11	8	6
72	1829	13	9	7
84	2134	15	11	8
96	2438	17	12	9
120	3048	21	15	11
144	3658	25	17	13
For Other Widths, Use Odd Number of Sprockets ^c at Maximum 6 in. (152 mm) \varnothing Spacing			Maximum 9 in. (229 mm) \varnothing Spacing	Maximum 12 in. (305 mm) \varnothing Spacing

- a. If your belt width exceeds a number listed in the table, please refer to the sprocket and support material minimums for the next larger width range listed. **If the actual width is critical, consult Customer Service.**
- b. These are the minimum number of sprockets. Additional sprockets may be required for heavily loaded applications.
- c. The center sprocket should be locked down. See Locked Sprocket Location chart in the Installation Instruction Guidelines or call Customer Service for lock down location.

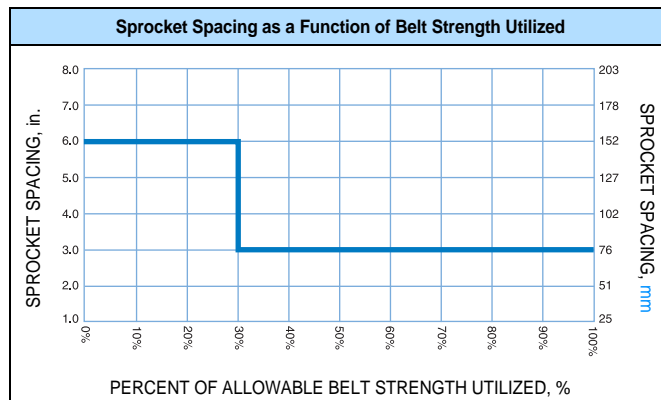
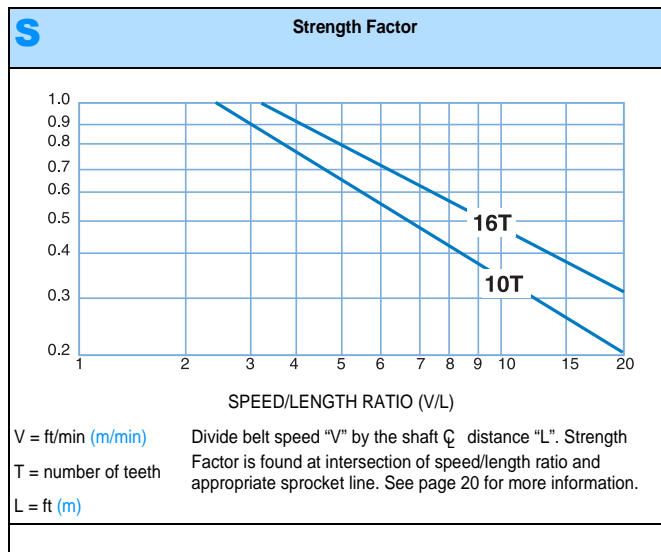

Split Metal Sprocket										
No. of Teeth (Chordal Action)	Nom. Pitch Dia. in.	Nom. Pitch Dia. mm	Nom. Outer Dia. in.	Nom. Outer Dia. mm	Nom. Hub Width in.	Nom. Hub Width mm	Available Bore Sizes			
							U.S. Sizes		Metric Sizes	
							Round in.	Square in.	Round mm	Square mm
10 (4.89%)	6.7	170	7.0	177	1.7	43		2.5		60
15 (2.19%)	10.0	254	10.3	262	1.7	43		3.5		
16 (1.92%)	10.6	269	11.0	279	1.7	43	3.5	3.5		90



Two-Material Finger Transfer Plates

Available Widths		Number of Fingers	Available Materials
in.	mm		
6.0	152	18	Glass-Filled Thermoplastic Fingers, Acetal Backplate

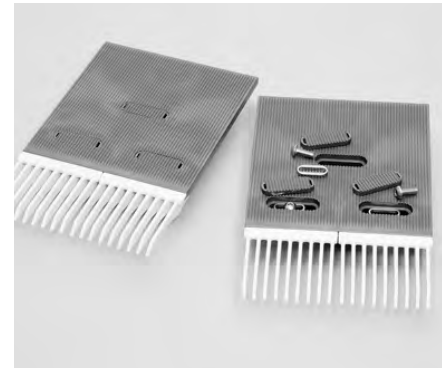

Note: Plates provide high strength fingers combined with a low-friction back plate.

Note: Low-friction back plate is permanently attached to the two high-strength finger inserts.

Note: Eliminates product transfer and tipping problems. The 18 fingers extend between the belt's ribs allowing a smooth continuation of the product flow as the belt engages its sprockets.

Note: Easily installed on the conveyor frame with the shoulder bolts supplied. Caps snap easily into place over the bolts, keeping foreign materials out of the slots.

Note: The extended back plate has three attachment slots. Mounting hardware is sold separately and includes stainless steel oval washers and bolts. Plastic bolt covers are also included.

Dimensional Requirements for Finger Transfer Plate Installation

	Two-Material	
	in.	mm
F	3.50	89
G	0.31	8
H	9.56	243
I	5.91	150
J	3.00	76
K	1.45	37
L	5.50	140
Spacing at ambient temperature	Enduralox™ PP	
	5.98	151.9

Two-material glass handling finger transfer plate shown

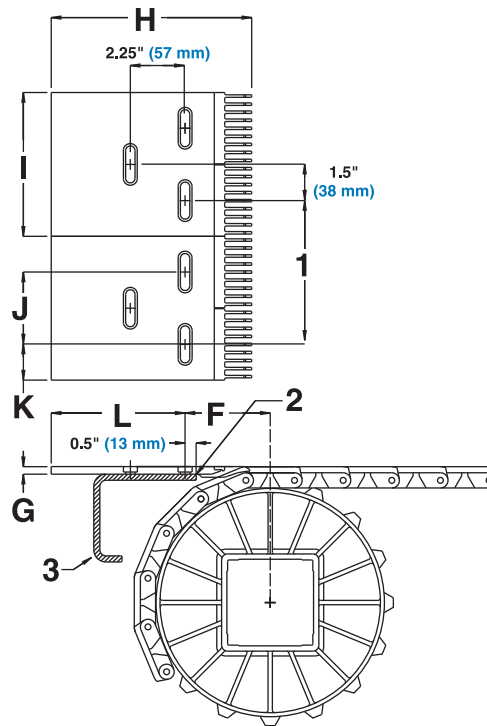

- 1 - SPACING
- 2 - 0.5" (13 mm) RADIUS (LEADING EDGE OF FRAME MEMBER)
- 3 - FRAME MEMBER

Self-Clearing Finger Transfer Plates^a

Available Width		Number of Fingers	Available Materials
in.	mm		
6	152	18	Glass-Filled Thermoplastic

Note: The Self-Clearing Finger Transfer System consists of a finger transfer plate and a transfer edge belt that are designed to work together. This system eliminates the need for a sweeper bar, a pusher arm, or wide transfer plates. Transfers are smooth and 100% self-clearing, making right angle transfers possible for all container types. The Self-Clearing Finger Transfer System is ideal for warmer/cooler applications with frequent product changeovers and is compatible with any series and style of Intralox belt on the discharge and infeed conveyors. This system is bi-directional allowing the same transfer belt to be used for both left-hand and right-hand transfers.



Note: Self-Clearing Finger Transfer System is capable of transferring product to and from Intralox Series 400, Series 1200 and Series 1900 Raised Rib belts.

Note: Smooth, flat top surface provides excellent lateral movement of containers.

Note: Robust design for durability in tough glass applications.

Note: Finger Transfer Plates are easily installed and secured to mounting plates of any thickness with stainless steel bolts and oval washers that allow movement with the belt's expansion and contraction.

Note: Stainless steel hardware is sold separately.

Note: Self-Clearing Transfer Edge Belt is molded with robust tracking tabs for belt support in heavy side-loading conditions. It has fully flush edges, headed rod retention system and nylon rods for superior wear resistance.

a. Licensed under Rexnord U.S. Patent Nos. 7,314,130 and 7,448,490

Dimensional Requirements for Self-Clearing Finger Transfer Plate Installations^a

	Self-Clearing	
	in.	mm
F	5.25	133.4
G	1.15	29.2
H	8.05	204.5
I	5.93	150.6
J	2.92	74.2
K	1.51	38.4
L	2.71	68.8
Spacing at ambient temperature		
PP	5.98 in.	151.9 mm

1 - Spacing

2 - Frame Member

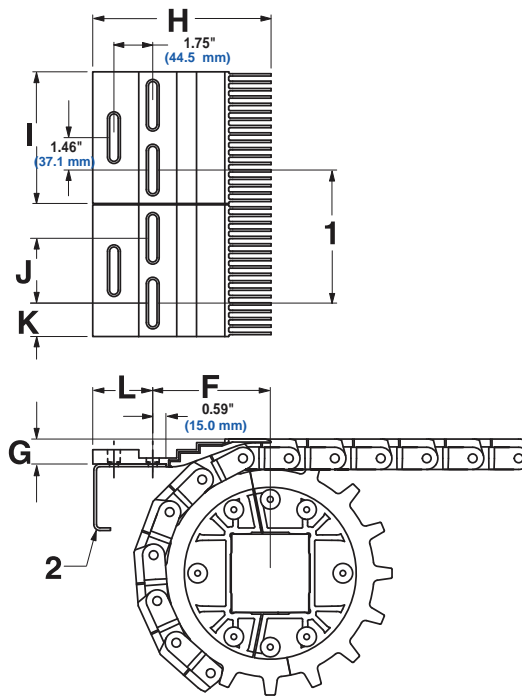

a. Licensed under Rexnord U.S. Patent Nos. 7,314,130 and 7,448,490

Conveyor Frame Dimensions

Regardless of type or configuration, all conveyors using Intralox belts have some basic dimensional requirements. Specifically, dimensions “A”, “B”, “C” and “E” listed below should be implemented in any design.

For general applications and applications where end transfer of tip-sensitive product is not critical, use the “A” dimension at the bottom of the range.

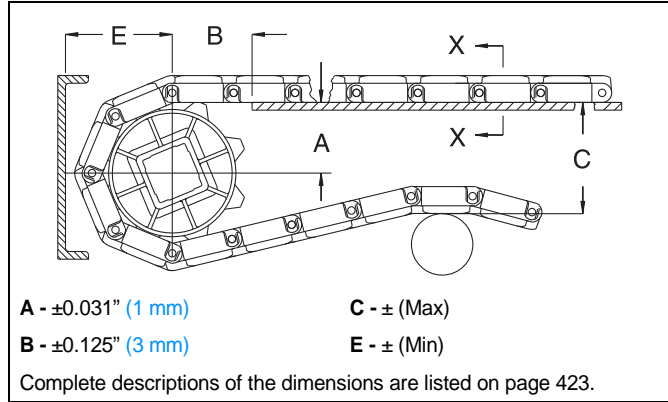

Sprocket Description		A		B		C		E		
Pitch Diameter		Range (Bottom to Top)		in.	mm	in.	mm	in.	mm	
in.	mm	No. Teeth	in.							mm
SERIES 1900 RAISED RIB										
6.7	170	10	2.69-2.85	68-72	2.82	72	7.08	180	4.29	109
10.0	254	15	4.37-4.48	111-114	3.52	89	10.33	262	5.91	150
10.6	269	16	4.71-4.81	120-122	3.65	93	11	279	6.25	159

Dead Plate Gap

Where there is a transfer point from a belt without finger transfer plates to a dead plate, there should be a gap between the surfaces to allow for the chordal action of the belt. As the belt engages its sprockets, chordal action causes the modules to move past a *fixed* point (the tip of the dead plate) with *varying* clearances. The table below shows the minimum amount of gap which occurs at the “low point” of the modules if the tip of the dead plate just comes in contact with the “high point” as the modules pass.

In some installations it may be desirable to keep the tip of the dead plate in contact with the belt, rather than allow a gap to occur. This can be done by hinging the mounting bracket for the dead plate. This allows the dead plate to move as the modules pass, but results in a small oscillating motion which may present tippage problems for sensitive containers or products.

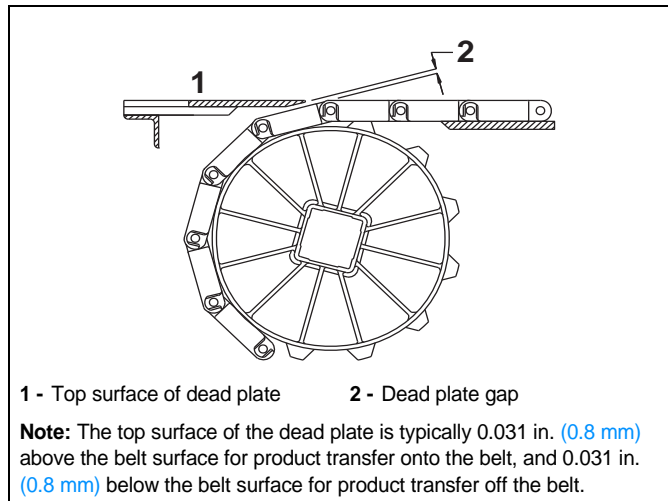

Sprocket Description			Gap	
Pitch Diameter		No. Teeth	in.	mm
in.	mm			
6.7	170	10	0.164	4.2
10.0	254	15	0.109	2.8
10.6	269	16	0.102	2.6

Transverse Roller Top™ (TRT™)

	in	mm
Pitch	2.00	50.8
Minimum Width	8	203
Width Increments	2.00	50.8
Opening Sizes (approx.)	0.43 x 0.53	10.9 x 13.5
Open Area	17.8%	
Hinge Style	Open	
Drive Method	Center	



Product Notes

- **Contact Intralox for precise belt measurements and stock status before designing equipment or ordering a belt.**
- Acetal rollers, plastic axles
- Designed for 90-Degree Transfers
- Roller diameter 0.95 in (24.1 mm)
- Roller length 0.825 in (20.9 mm)
- Standard roller indent 0.26 in (6.6 mm)
- 2 in (50.8 mm) roller spacing, alternating
- Belt length must be adjusted in 4 in (2 row) increments
- Uses headless rods.
- Sprockets have large lug teeth.
- Robust design offers excellent belt and sprocket durability, especially in tough, material-handling applications
- S4400 alternating tooth glass filled split sprocket recommended for this belt.
- Contact Intralox Customer Service for detailed conveyor design guidelines.

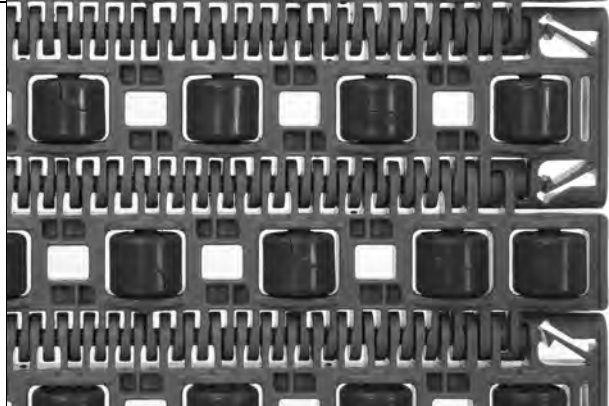

Additional Information

- See "Belt Selection Process" (page 5)
- See "Standard Belt Materials" (page 9)
- See "Special Application Belt Materials" (page 9)
- See "Friction Factors" (page 13)

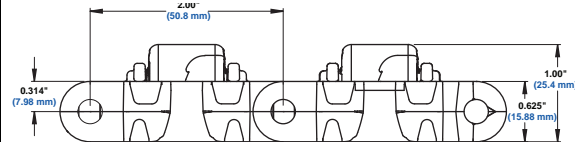

Belt Data

Belt Material	Standard Rod Material Ø 0.240 in (6.1 mm)	BS Straight Belt Strength		Temperature Range (continuous)		W Belt Weight	
		lb./ft.	kg/m	°F	°C	lb./ft. ²	kg/m ²
Polypropylene	Nylon	2200	3270	34 to 200	1 to 93	2.25	10.985

Sprocket and Support Quantity Reference				
Belt Width Range ^a		Minimum Number of Sprockets Per Shaft ^b	Wearstrips	
in.	mm		Carryway	Returnway
10-14	254-356	2	3	2
16-18	406-457	3	3	3
20-24	508-610	3	4	3
26	660	4	4	3
28-32	711-813	4	5	3
34-36	864-914	5	5	4
38-42	965-1067	5	6	4
44	1118	6	6	5
46-50	1168-1270	6	7	5
52-54	1321-1372	7	7	5
56-60	1422-1524	7	8	6
62	1575	8	8	6
64-68	1626-1727	8	9	6
70-72	1778-1829	9	9	6
74-78	1879-1981	9	10	7
80	2032	10	10	7
Maximum 9 in. (229 mm) CL Spacing, Minimum indent from Flush Edge			Maximum 9 in. (229 mm) CL Spacing	Maximum returnway spacing 12 in.

- a. If your belt width exceeds a number listed in the table, please refer to the sprocket and support material minimums for the next larger width range listed. Belts are available in 2.00 in. (51 mm) increments beginning with minimum width of 10 in. (254 mm). **If the actual width is critical, consult Customer Service.**
- b. These are the minimum number of sprockets. Additional sprockets may be required for heavily loaded applications.

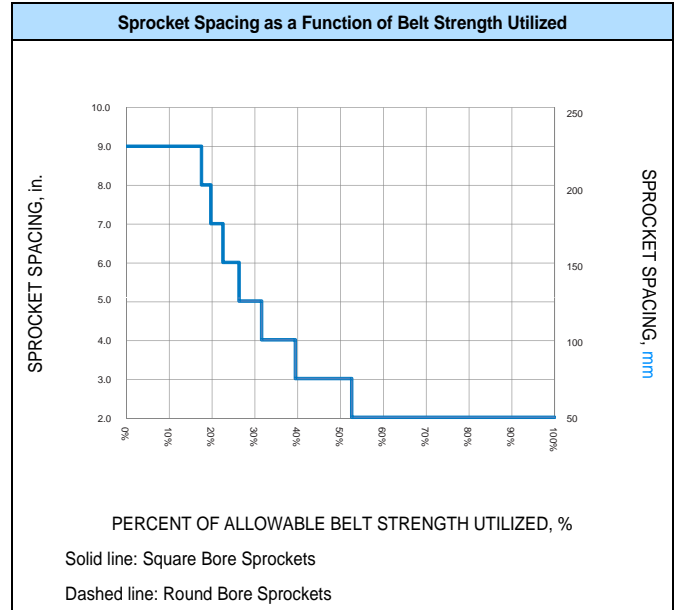
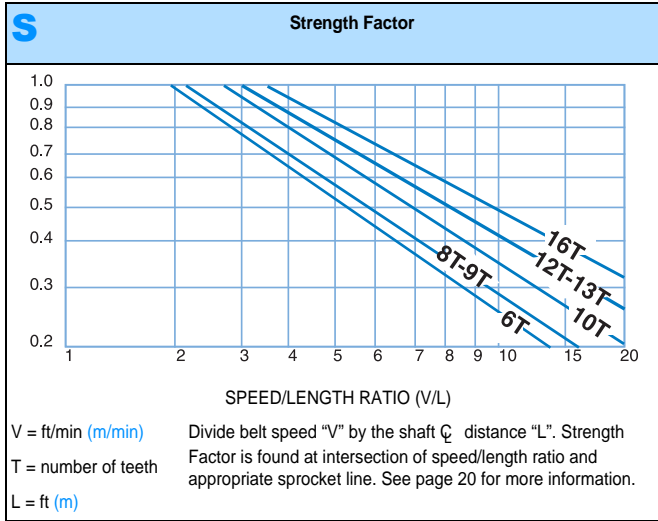

Glass Filled Nylon Alternating Tooth Split Sprocket^a										
No. of Teeth (Chordal Action)	Nom. Pitch Dia. in	Nom. Pitch Dia. mm	Nom. Outer Dia. in	Nom. Outer Dia. mm	Nom. Hub Width in	Nom. Hub Width mm	Available Bore Sizes			
							U.S. Sizes		Metric Sizes	
							Round in	Square in	Round mm	Square mm
10 (4.89%)	6.5	165	6.7	170	1.9	48		1.5 2.5		40 60
12 (3.41%)	7.8	198	8.0	198	1.9	48		1.5 2.5		40 60
16 (1.92%)	10.3	262	10.5	267	1.9	48		1.5 2.5		40 60



a. Contact Customer Service for lead times.

Nylon Alternating Tooth Split Sprocket^a										
No. of Teeth (Chordal Action)	Nom. Pitch Dia. in	Nom. Pitch Dia. mm	Nom. Outer Dia. in	Nom. Outer Dia. mm	Nom. Hub Width in	Nom. Hub Width mm	Available Bore Sizes			
							U.S. Sizes		Metric Sizes	
							Round in	Square in	Round mm	Square mm
8 (7.61%)	5.3	135	5.5	140	1.9	48		1.5		40
16 (1.92%)	10.3	262	10.5	267	1.9	48		3.5		

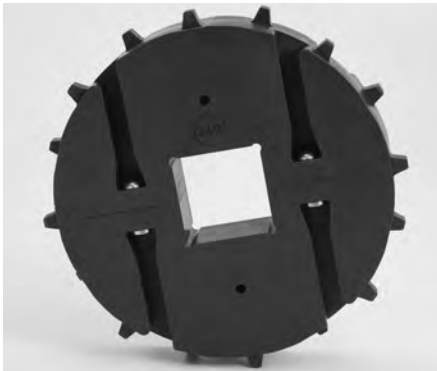

a. Contact Customer Service for lead times.

Nylon Alternating Tooth Sprocket^a										
No. of Teeth (Chordal Action)	Nom. Pitch Dia. in	Nom. Pitch Dia. mm	Nom. Outer Dia. in	Nom. Outer Dia. mm	Nom. Hub Width in	Nom. Hub Width mm	Available Bore Sizes			
							U.S. Sizes		Metric Sizes	
							Round in	Square in	Round mm	Square mm
6 (13.40%)	4.0	102	4.2	107	1.9	48		1.5		40

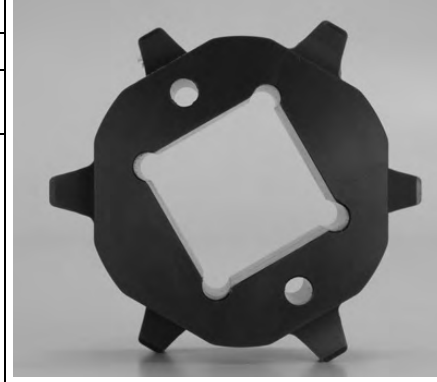

a. Contact Customer Service for lead times.

Glass Filled Nylon Alternating Tooth Sprocket^a

No. of Teeth (Chordal Action)	Nom. Pitch Dia. in	Nom. Pitch Dia. mm	Nom. Outer Dia. in	Nom. Outer Dia. mm	Nom. Hub Width in	Nom. Hub Width mm	Available Bore Sizes			
							U.S. Sizes		Metric Sizes	
							Round in	Square in	Round mm	Square mm
10 (4.89%)	6.5	165	6.5	165	2.0	51		1.5 2.5		40 60
12 (3.41%)	7.8	198	7.8	198	2	51		1.5 2.5		40 60
16 (1.92%)	10.3	262	10.4	264	2	51		2.5		60



a. Contact Customer Service for lead times.

Conveyor Frame Dimensions

Regardless of type or configuration, all conveyors using Intralox belts have some basic dimensional requirements. Specifically, dimensions “A”, “B”, “C” and “E” listed below should be implemented in any design.

For general applications and applications where end transfer of tip-sensitive product is not critical, use the “A” dimension at the bottom of the range.

Conveyor frame dimensions are established using the top of the roller as the top of the belt and the bottom of the module as the bottom of the belt. “B” dimension is based on a 0.5 in. (12.7 mm) thick carryway.

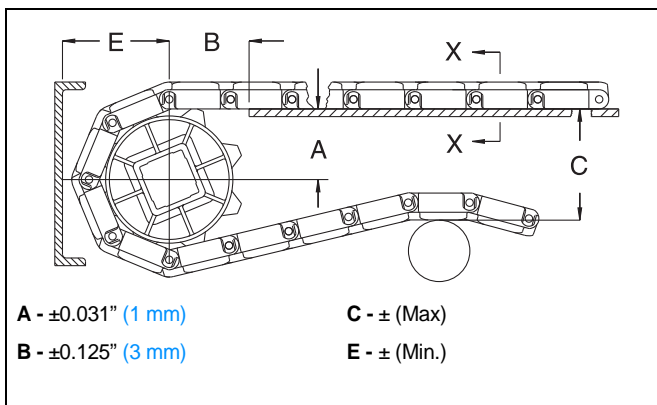

Sprocket Description		A		B		C		E		
Pitch Diameter		No. Teeth	Range (Bottom to Top)		in.	mm	in.	mm	in.	mm
in.	mm		in.	mm						
4.0	102	6	1.43-1.70	36-43	1.85	47	4.40	112	2.76	70
5.3	135	8	2.12-2.32	54-59	2.24	57	5.64	143	3.38	86
6.5	165	10	2.79-2.95	71-75	2.39	61	6.90	175	4.01	102
7.8	198	12	3.45-3.58	88-91	2.64	67	8.16	207	4.64	118
10.3	262	16	4.75-4.85	121-123	3.10	79	10.70	272	5.91	150

Flush Grid		
	in	mm
Pitch	2.00	50.8
Minimum Width	5	127
Width Increments	1.00	25.4
Opening Sizes (approx.)	0.24 x 0.23	6.1 x 5.8
Open Area	35%	
Hinge Style	Open	
Drive Method	Center-Driven	
Product Notes		
<ul style="list-style-type: none"> • Contact Intralox for precise belt measurements and stock status before designing equipment or ordering a belt. • Smooth upper surface and straightforward design provides free product movement. • Uses headless rods. • Sprockets have large lug teeth. • Opening size prevents 1/4 inch or larger bolt from falling through belt surface. 		
Additional Information		
<ul style="list-style-type: none"> • See "Belt Selection Process" (page 5) • See "Standard Belt Materials" (page 9) • See "Special Application Belt Materials" (page 9) • See "Friction Factors" (page 13) 		

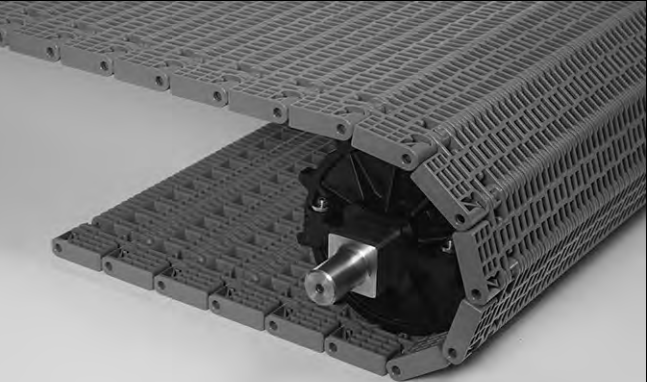
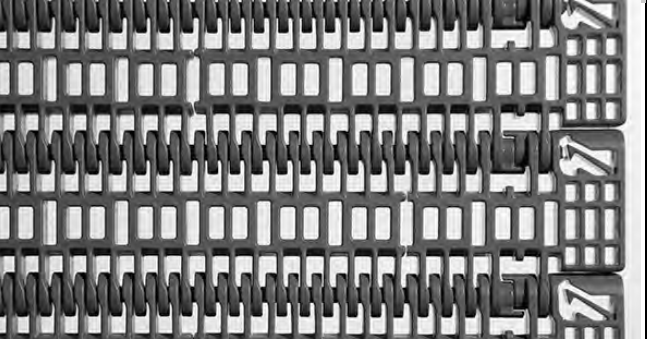
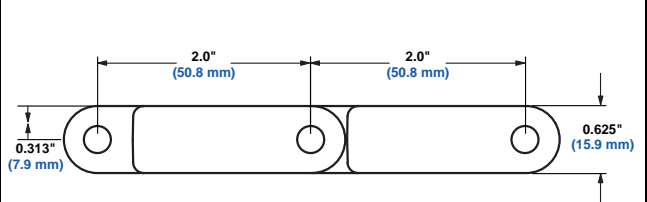
Belt Data									
Belt Material	Standard Rod Material Ø 0.24 in (6.1 mm)	BS	Belt Strength		Temperature Range (continuous)		W	Belt Weight	
			lb./ft.	kg/m	°F	°C		lb./ft. ²	kg/m ²
Polypropylene	Nylon	2400	3572	34 to 220	1 to 104	1.54	7.52		
Polypropylene	Polypropylene	2200	3274	34 to 220	1 to 104	1.54	7.52		

Flat Top		
	in	mm
Pitch	2.00	50.8
Minimum Width	5.00	127
Width Increments	1.00	25.4
Opening Sizes (approx.)	—	—
Open Area	0%	
Hinge Style	Closed	
Drive Method	Center-Driven	
Product Notes		
<ul style="list-style-type: none"> • Contact Intralox for precise belt measurements and stock status before designing equipment or ordering a belt. • Smooth, closed upper surface. • Uses headless rods. • Available in yellow edges. Staggered yellow edges make it easy to distinguish the moving belt from the stationary floor. • Wheel chocks are available. Series 4500 Flat Top modules are used to mount the wheel chocks. • Fully flush edges with Slidelox® rod retention feature. • Slidelox is a glass-reinforced polypropylene. 		
Additional Information		
<ul style="list-style-type: none"> • See “Belt Selection Process” (page 5) • See “Standard Belt Materials” (page 9) • See “Special Application Belt Materials” (page 9) • See “Friction Factors” (page 13) 		

Belt Data							
Belt Material	Standard Rod Material Ø 0.24 in (6.1 mm)	BS	Belt Strength	Temperature Range (continuous)		W	Belt Weight
				°F	°C		
Acetal	Nylon	4400	6548	-50 to 200	-46 to 93	3.07	14.96
HSEC Acetal	Nylon	4100	6101	-50 to 200	-46 to 93	3.08	15.04
AC/EC	Nylon	4400	6548	-50 to 200	-46 to 93	3.08	15.04
Polypropylene	Nylon	3900	5804	34 to 200	1 to 93	1.97	9.62
Polypropylene	Polypropylene	2500	3720	34 to 220	1 to 104	1.85	9.03
Easy Release Traceable Polypropylene	Nylon	2500	3720	34 to 220	1 to 104	2.26	11.03

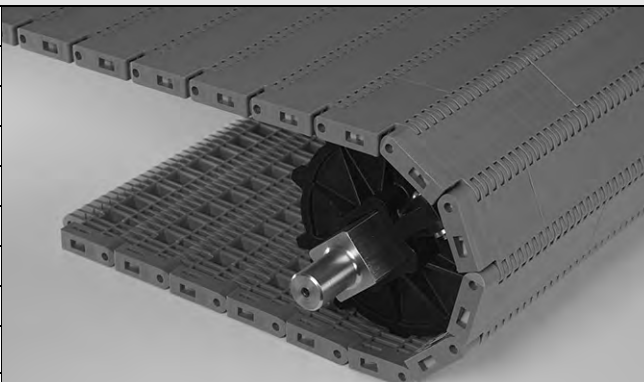
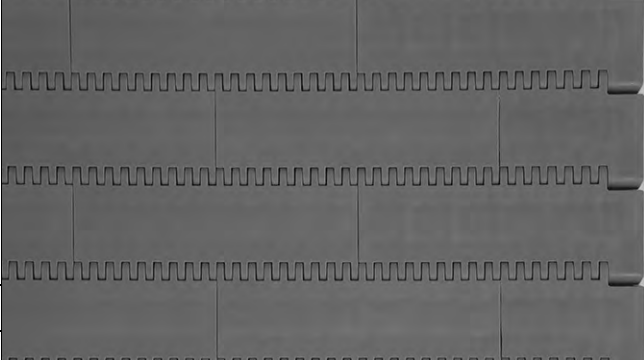
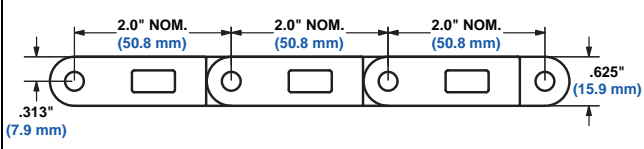
Non Skid		
	in	mm
Pitch	2.00	50.8
Minimum Width	5.00	127
Width Increments	1.00	25.4
Opening Sizes (approx.)	—	—
Open Area	0%	
Hinge Style	Closed	
Drive Method	Center-Driven	

Product Notes

- Contact Intralox for precise belt measurements and stock status before designing equipment or ordering a belt.
- Diamond tread pattern provides a non-skid walking surface to increase safety.
- Available in yellow edges. Staggered yellow edges make it easy to distinguish the moving belt from the stationary floor.
- Wheel chocks are available. Series 4500 Flat Top modules are used to mount the wheel chocks.
- Edges have Flat Top surface (no tread pattern). Flat Top indent is 2.0 in (50 mm) from edge of belt.
- Fully flush edges with Slidelox® rod retention feature.
- Slidelox is a glass-reinforced polypropylene.
- Uses headless rods.

Additional Information

- See “Belt Selection Process” (page 5)
- See “Standard Belt Materials” (page 9)
- See “Special Application Belt Materials” (page 9)
- See “Friction Factors” (page 13)

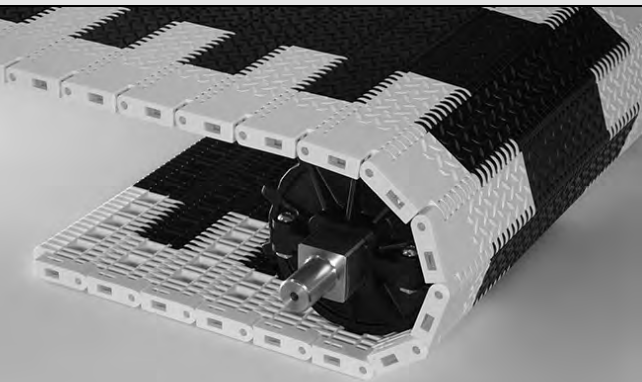
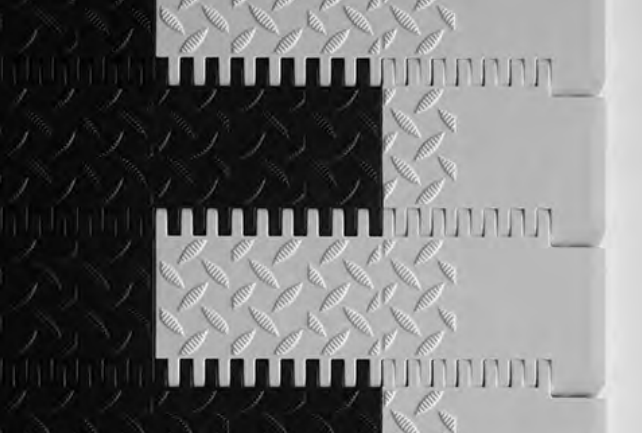
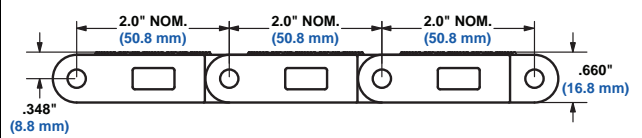
Belt Data							
Belt Material	Standard Rod Material Ø 0.24 in (6.1 mm)	BS	Belt Strength	Temperature Range (continuous)		W	Belt Weight
		lb/ft	kg/m	°F	°C	lb/ft ²	kg/m ²
Acetal	Nylon	4400	6548	-50 to 200	-46 to 93	3.09	15.09
HSEC Acetal	Nylon	4100	6101	-50 to 200	-46 to 93	3.10	15.14
AC/EC	Nylon	4400	6548	-50 to 200	-46 to 93	3.10	15.14
Polypropylene	Nylon	3900	5804	34 to 200	1 to 93	1.98	9.67
Polypropylene	Polypropylene	2500	3720	34 to 220	1 to 104	1.86	9.08
FR Anti-Static	Nylon	2000	2976	-50 to 150	-46 to 66	3.00	14.65

Non Skid Raised Rib		
	in	mm
Pitch	2.00	50.8
Minimum Width	5.00	127
Width Increments	1.00	25.4
Opening Sizes (approx.)	—	—
Open Area	0%	
Hinge Style	Closed	
Drive Method	Center-Driven	
Product Notes		
<ul style="list-style-type: none"> • Contact Intralox for precise belt measurements and stock status before designing equipment or ordering a belt. • Tread pattern provides a non-skid walking surface to increase safety. • Available in yellow edges. Staggered yellow edges make it easy to distinguish the moving belt from the stationary floor. • Series 4500 finger plates are available to shed miscellaneous objects from the surface of the belt. • Edges have Flat Top surface (no tread pattern). Flat Top indent is 2.0 in (50 mm) from edge of belt. • Fully flush edges with Slidelox® rod retention feature. • Slidelox is a glass-reinforced polypropylene. • Uses headless rods. 		
Additional Information		
<ul style="list-style-type: none"> • See “Belt Selection Process” (page 5) • See “Standard Belt Materials” (page 9) • See “Special Application Belt Materials” (page 9) • See “Friction Factors” (page 13) 		



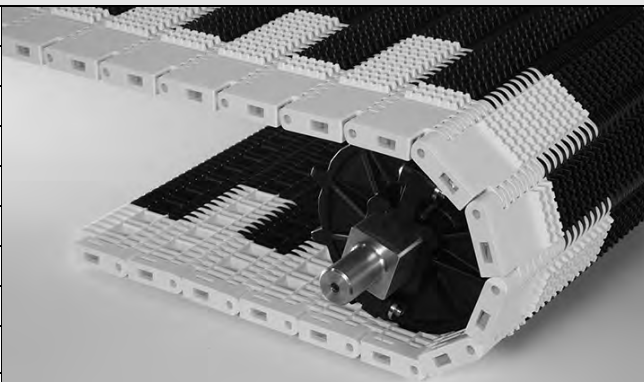
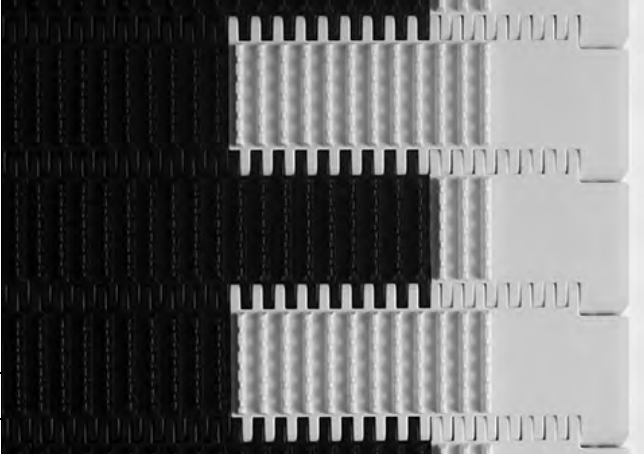
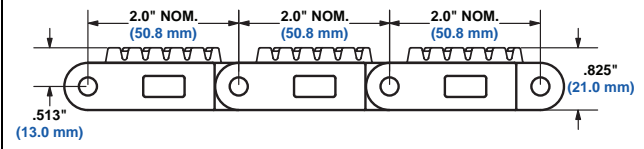

Belt Data							
Belt Material	Standard Rod Material Ø 0.24 in (6.1 mm)	BS		Temperature Range (continuous)		W	
		Belt Strength		°F	°C	Belt Weight	
		lb/ft	kg/m			lb/ft ²	kg/m ²
Acetal	Nylon	4400	6548	-50 to 200	-46 to 93	3.39	16.55
HSEC Acetal	Nylon	4100	6101	-50 to 200	-46 to 93	3.39	16.55
AC/EC	Nylon	4400	6548	-50 to 200	-46 to 93	3.39	16.55

Sprocket and Support Quantity Reference				
Belt Width Range ^a		Minimum Number of Sprockets Per Shaft ^b	Wearstrips	
in.	mm		Carryway	Returnway
2	51	1	2	2
4	102	1	2	2
6	152	2	2	2
7	178	2	2	2
8	203	2	2	2
10	254	2	3	2
12	305	3	3	2
14	356	3	3	3
15	381	3	3	3
16	406	3	3	3
18	457	3	3	3
20	508	5	4	3
24	610	5	4	3
30	762	5	5	4
32	813	7	5	4
36	914	7	5	4
42	1087	7	6	5
48	1219	9	7	5
54	1372	9	7	6
60	1524	11	8	6
72	1829	13	9	7
84	2134	15	11	8
96	2438	17	12	9
120	3048	21	15	11
144	3658	25	17	13
For Other Widths, Use Odd Number of Sprockets ^c at Maximum 6 in. (152 mm) \varnothing Spacing			Maximum 9 in. (229 mm) \varnothing Spacing	Maximum 12 in. (305 mm) \varnothing Spacing

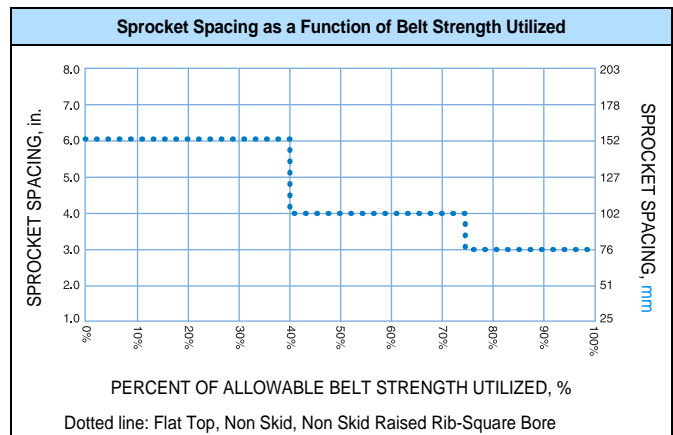
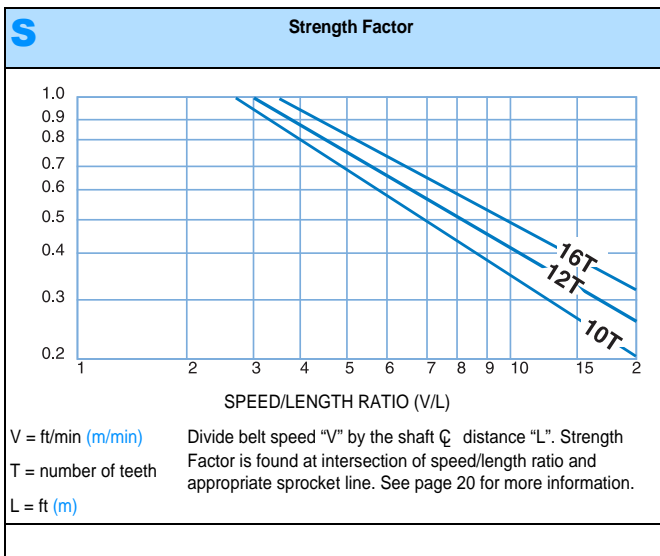
- If your belt width exceeds a number listed in the table, please refer to the sprocket and support material minimums for the next larger width range listed. Belts are available in 1.00 in. (25.4 mm) increments beginning with minimum width of 5 in. (127 mm). **If the actual width is critical, consult Customer Service.**
- These are the minimum number of sprockets. Additional sprockets may be required for heavily loaded applications.
- The center sprocket should be locked down. With only two sprockets, fix the sprocket on the drive journal side only. See Retainer Rings/Center Sprocket Offset chart on page 410 for lock down location.

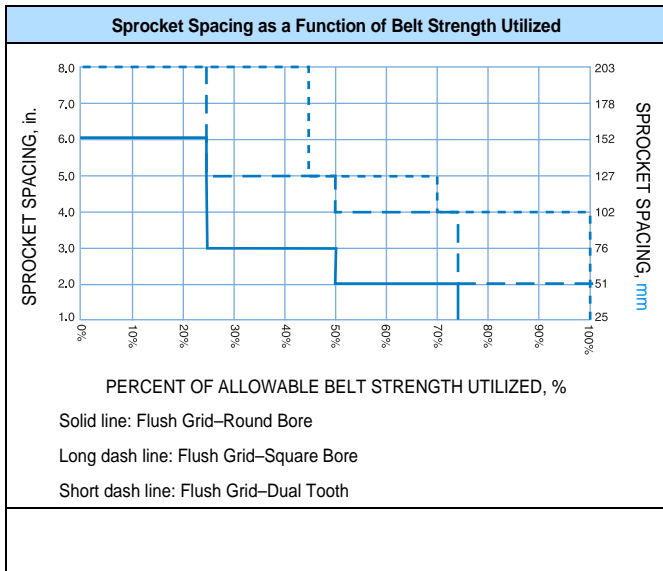



Enduralox Polypropylene Composite Split Sprocket^{ab}

No. of Teeth (Chordal Action)	Nom. Pitch Dia. in	Nom. Pitch Dia. mm	Nom. Outer Dia. in	Nom. Outer Dia. mm	Nom. Hub Width in	Nom. Hub Width mm	Available Bore Sizes			
							U.S. Sizes		Metric Sizes	
							Round in	Square in	Round mm	Square mm
10 (4.89%)	6.5	165	6.7	170	1.5	38	1.5 2.5		40 60	
12 (3.41%)	7.8	198	8	203	1.5	38	1.5 2.5		40 60	
16 (1.92%)	10.3	262	10.5	267	1.5	38	2.5 ^c 3.5 ^c	2.5 ^c	60 ^c 90 ^c	60 ^c



- a. Contact Customer Service for lead times.
- b. Hardware made from 316 Stainless Steel
- c. Bores are over-sized

Glass Filled Nylon Split Sprocket^a

No. of Teeth (Chordal Action)	Nom. Pitch Dia. in	Nom. Pitch Dia. mm	Nom. Outer Dia. in	Nom. Outer Dia. mm	Nom. Hub Width in	Nom. Hub Width mm	Available Bore Sizes			
							U.S. Sizes		Metric Sizes	
							Round in	Square in	Round mm	Square mm
10 (4.89%)	6.5	165	6.7	170	1.45	37	1.5 ^b 2.5		40 ^b 60	
12 (3.41%)	7.8	198	8	203	1.45	37	1.5 ^b 2.5 3.5		40 ^b 60 90	
16 (1.92%)	10.3	262	10.5	267	1.45	37	2.5 3.5		60 90	



- a. Contact Customer Service for lead times.
- b. 1.5 in and 40 mm bores have a hub width of 1.95 in (50 mm).

Nylon Split Sprocket^a										
No. of Teeth (Chordal Action)	Nom. Pitch Dia. in	Nom. Pitch Dia. mm	Nom. Outer Dia. in	Nom. Outer Dia. mm	Nom. Hub Width in	Nom. Hub Width mm	Available Bore Sizes			
							U.S. Sizes		Metric Sizes	
							Round in	Square in	Round mm	Square mm
16 (1.92%)	10.3	262	10.5	267	1.9	38		1.5		40

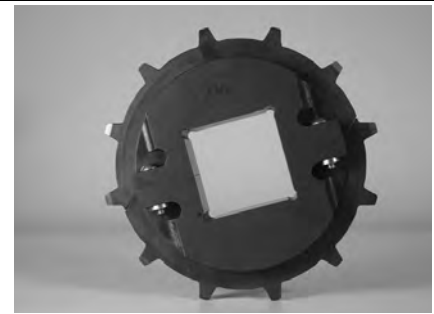

a. Contact Customer Service for lead times.

Glass Filled Nylon Sprocket^a										
No. of Teeth (Chordal Action)	Nom. Pitch Dia. in	Nom. Pitch Dia. mm	Nom. Outer Dia. in	Nom. Outer Dia. mm	Nom. Hub Width in	Nom. Hub Width mm	Available Bore Sizes			
							U.S. Sizes		Metric Sizes	
							Round in	Square in	Round mm	Square mm
10 (4.89%)	6.5	165	6.5	165	2	51		1.5 2.5		40 60
12 (3.41%)	7.8	198	7.8	198	2	51		1.5 2.5		40 60



a. Contact Customer Service for lead times.

Enduralox Polypropylene Composite Dual Tooth Split Sprocket^{ab}										
No. of Teeth (Chordal Action)	Nom. Pitch Dia. in	Nom. Pitch Dia. mm	Nom. Outer Dia. in	Nom. Outer Dia. mm	Nom. Hub Width in	Nom. Hub Width mm	Available Bore Sizes			
							U.S. Sizes		Metric Sizes	
							Round in	Square in	Round mm	Square mm
16 (1.92%)	10.3	262	10.5	267	1.5	38		3.5 ^c		90 ^c

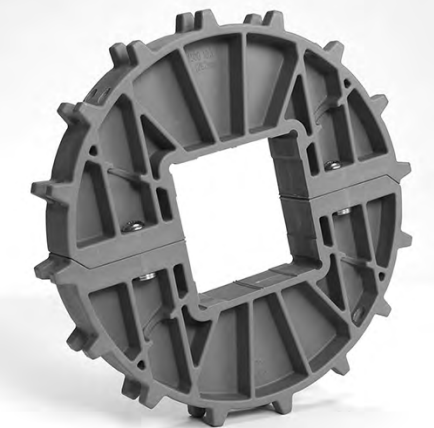

a. Contact Customer Service for lead times.
 b. Hardware made from 316 Stainless Steel
 c. Bores are over-sized

SECTION 2

4500

Finger Transfer Plates

Available Widths		Number of Fingers	Available Materials
in	mm		
6	152	18	Glass-Filled Thermoplastic Fingers, Acetal Back Plate

Note: For use with Series 4500 Non-Skid Raised Rib belt styles.

Note: Fingers extend between the ribs to prevent hardware from dropping off the end of the conveyor.

Note: Plastic shoulder bolts and bolt covers are included for installing the standard two-material finger transfer plates.

Note: Easily installed on the conveyor frame.

Note: Available in two different configurations:

Standard - long fingers with a short back plate

Standard Extended Back - long fingers with an extended back plate

The short back plate has two attachment slots and the extended back plate has three attachment slots.

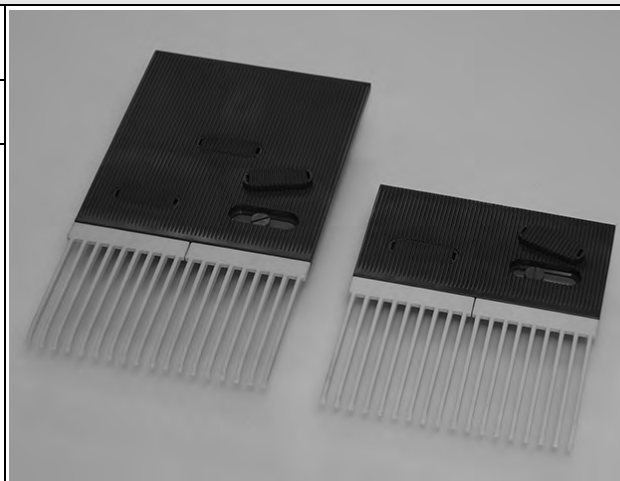

Flat Top Wheel Chock

Available Height		Available Width		Available Materials
in	mm	in	mm	
1.6	41	5	127	UHMW
1.97	50	5	127	UHMW

Note: Fasteners and modified S4500 Flat Top modules are required.

Note: The fastener torque specification is 40-45 in.-lbs (4.5-5 N-m).

Note: The minimum indent from the edge of the belt (without wheel chocks) is 2.0 in (50 mm).

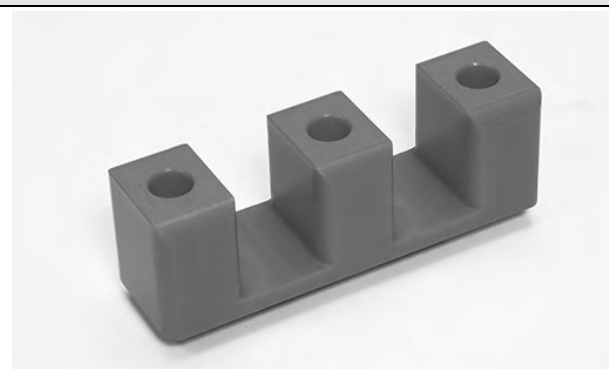

Insert Nuts

Available Base Belt Style - Material	Available Insert Nut Sizes
Series 4500 Flat Top - Acetal	6 mm - 1 mm 8 mm - 1.25 mm
Series 4500 Flat Top - Polypropylene	6 mm - 1 mm 8 mm - 1.25 mm

Note: Insert Nuts easily allow the attachment of fixtures to the belt.

Note: Fasteners and modified Series 4500 Flat Top modules are required.

Note: The fastener torque specification is 40-45 in.-lbs (4.5-5.0 N-m).

Note: Square insert nuts are provided. The square flange ensures that the insert nut stays in place when the bolt is tightened or loosened.

Note: Attachments connected to more than one row must not prohibit belt rotation around the sprockets.

Note: Sprockets cannot be located in-line with the insert nut locations. Contact Intralox Customer Service for sprocket and insert nut placement.

Note: Nut placement constraints are as follows: 2.5 in (63 mm) minimal indent from the belt edge; 1.0 in (25 mm) minimal distance between nuts along the length of the belt. Contact Intralox Customer Service for assistance with insert nut placement.

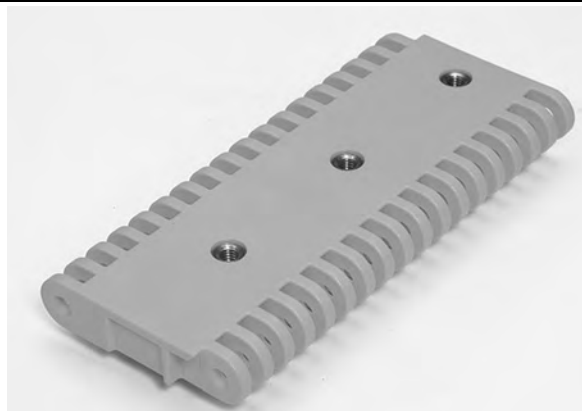

Conveyor Frame Dimensions

Regardless of type or configuration, all conveyors using Intralox belts have some basic dimensional requirements. Specifically, dimensions "A", "B", "C" and "E" listed below should be implemented in any design.

For general applications and applications where end transfer of tip-sensitive product is not critical, use the "A" dimension at the bottom of the range.

Conveyor frame dimensions are established using the top of the roller as the top of the belt and the bottom of the module as the bottom of the belt. "B" dimension is based on a 0.5 in. (12.7 mm) thick carryway.

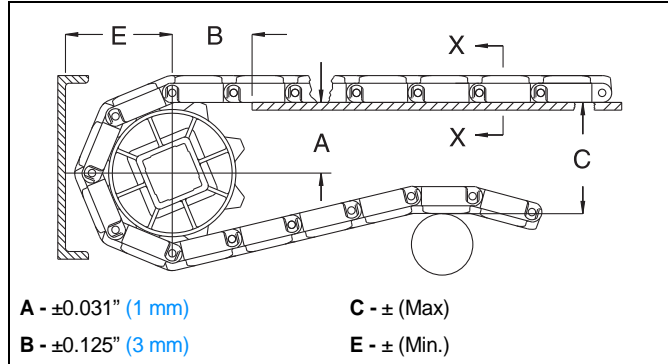

Sprocket Description			A		B		C		E	
Pitch Diameter		No. Teeth	Range (Bottom to Top)		in.	mm	in.	mm	in.	mm
in.	mm		in.	mm						
FLUSH GRID, FLAT TOP										
6.5	165	10	2.77-2.92	70-74	2.40	61	6.47	164	3.61	92
7.8	198	12	3.46-3.59	88-91	2.63	67	7.80	198	4.28	109
10.3	262	16	4.71-4.81	120-122	3.15	80	10.25	260	5.50	140
NON SKID										
6.5	165	10	2.77-2.92	70-74	2.40	61	6.56	167	3.70	94
7.8	198	12	3.46-3.59	88-91	2.63	67	7.89	200	4.36	111
10.3	262	16	4.71-4.81	120-122	3.15	80	10.34	263	5.59	142
NON SKID RAISED RIB										
6.5	165	10	2.77-2.92	70-74	2.40	61	6.67	169	3.81	97
7.8	198	12	3.46-3.59	88-91	2.63	67	8.00	203	4.48	114
10.3	262	16	4.71-4.81	120-122	3.15	80	10.45	265	5.70	145

Dead Plate Gap

Where there is a transfer point from a belt without finger transfer plates to a dead plate, there should be a gap between the surfaces to allow for the chordal action of the belt. As the belt engages its sprockets, chordal action causes the modules to move past a *fixed* point (the tip of the dead plate) with *varying* clearances. The table below shows the minimum amount of gap which occurs at the “low point” of the modules if the tip of the dead plate just comes in contact with the “high point” as the modules pass.

In some installations it may be desirable to keep the tip of the dead plate in contact with the belt, rather than allow a gap to occur. This can be done by hinging the mounting bracket for the dead plate. This allows the dead plate to move as the modules pass, but results in a small oscillating motion which may present tippage problems for sensitive containers or products.

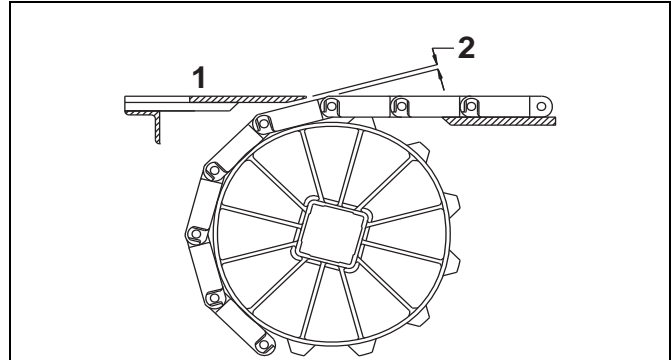

1 - Top surface of dead plate 2 - Dead plate gap

Note: The top surface of the dead plate is typically 0.031 in. (0.8 mm) above the belt surface for product transfer onto the belt, and 0.031 in. (0.8 mm) below the belt surface for product transfer off the belt.

Sprocket Description		Gap		
Pitch Diameter		No. Teeth	in.	mm
in.	mm			
6.4	163	10	0.160	4.1
7.8	198	12	0.130	3.3
10.1	257	16	0.100	2.5

Flush Grid		
	in	mm
Pitch	1.01	25.7
Minimum Width	6	152.4
Width Increments	1.00	25.4
Opening Sizes (approx.)	0.7 x 0.5	17.8 x 12.7
Open Area	58%	
Hinge Style	Closed	
Drive Method	Center (preferred)/Hinge-Driven	
Product Notes		
<ul style="list-style-type: none"> • Contact Intralox for precise belt measurements and stock status before designing equipment or ordering a belt. • Easy to retrofit from existing steel belting with virtually no conveyor changes • Split steel sprockets available; longer sprocket life and easier replacement • PVDF material is a polymer proven for long-term use in washer environments • Uses headless rods. • Open surface enhances spray-through cleaning performance and/or air flow cooling performance depending on the application 		
Additional Information		
<ul style="list-style-type: none"> • See <i>"Belt Selection Process"</i> (page 5) • See <i>"Standard Belt Materials"</i> (page 9) • See <i>"Special Application Belt Materials"</i> (page 9) • See <i>"Friction Factors"</i> (page 13) 		

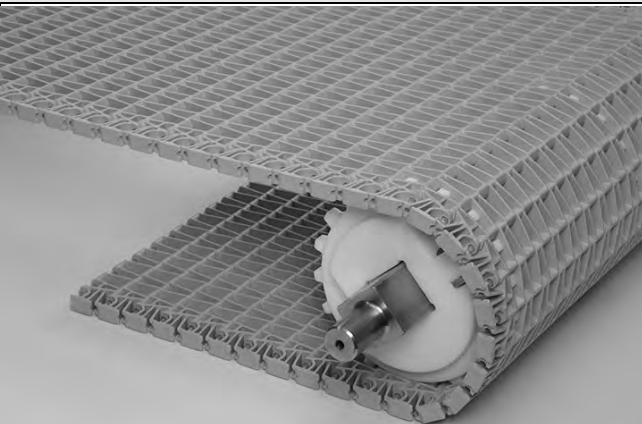
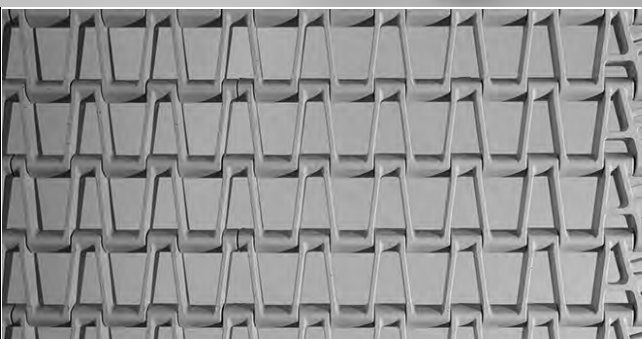
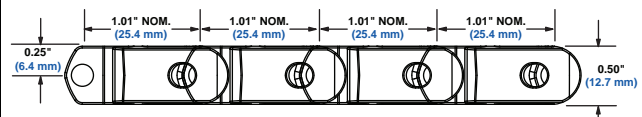
Belt Data								
Belt Material	Standard Rod Material Ø 0.18 in (4.6 mm)	BS	Belt Strength	Temperature Range (continuous)		W	Belt Weight	
			lb/ft	kg/m	°F	°C	lb/ft ²	kg/m ²
PVDF	PVDF		1000	1490	34 to 200	1 to 93	1.57	7.64
Polypropylene	Polypropylene		750	1120	34 to 220	1 to 104	0.82	4.00
Acetal	Polypropylene		900	1340	34 to 200	1 to 93	1.14	5.57

Sprocket and Support Quantity Reference				
Belt Width Range ^a		Minimum Number of Sprockets Per Shaft ^b	Wearstrips	
in.	mm		Carryway	Returnway
12	305	3	2	Minimum 3 in. (76.2 mm) diameter rollers.
24	610	6	4	
36	914	9	6	
48	1219	12	8	
60	1524	15	10	
72	1829	18	12	
84	2134	21	14	
96	2438	24	16	
For Other Widths, Use Odd Number of Sprockets ^c at Maximum 4 in. (102 mm) \varnothing Spacing				

- a. If your belt width exceeds a number listed in the table, please refer to the sprocket and support material minimums for the next larger width range listed. Belts are available in 1.00 in. (25.4 mm) increments beginning with minimum width of 6 in. (152.4 mm). **If the actual width is critical, consult Customer Service.**
- b. These are the minimum number of sprockets. Additional sprockets may be required for heavily loaded applications.
- c. The center sprocket should be locked down. With only two sprockets, fix the sprocket on the drive journal side only. See Center Sprocket Offset chart for lock down location.

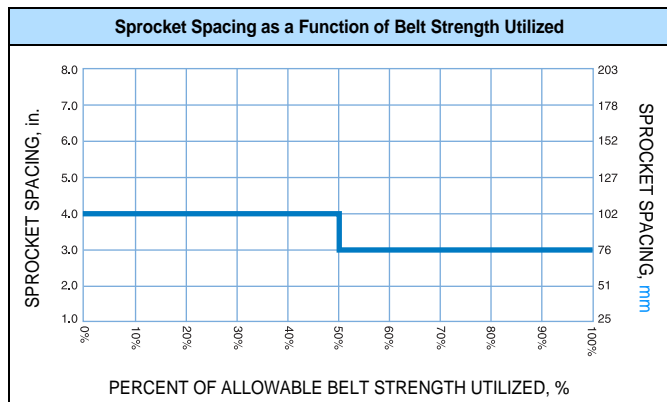
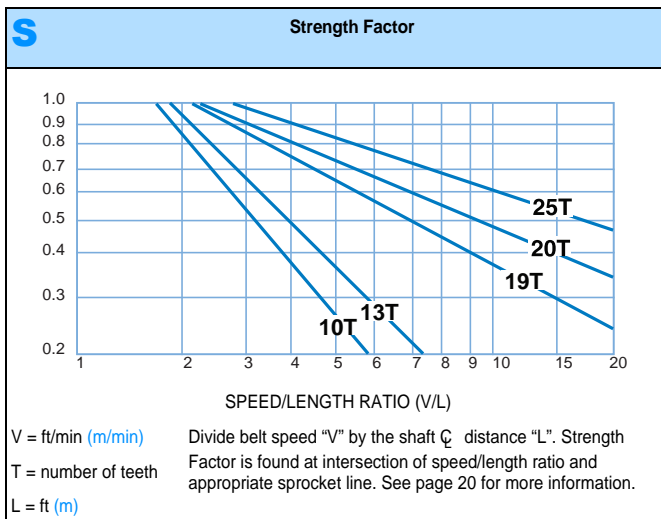

Split Metal Sprocket ^a											
No. of Teeth (Chordal Action)	Nom. Pitch Dia. in.	Nom. Pitch Dia. mm	Nom. Outer Dia. in.	Nom. Outer Dia. mm	Nom. Hub Width in.	Nom. Hub Width mm	Available Bore Sizes				
							U.S. Sizes		Metric Sizes		
							Round in.	Square in.	Round mm	Square mm	
20 (1.23%)	6.5	165	6.5	165	1.7	43	2-3/16 2-7/16 2-11/16 3-7/16	2.5			
25 (0.8%)	8.1	206	8.1	206	1.7	43	2-7/16 2-11/16 3-7/16	2.5			

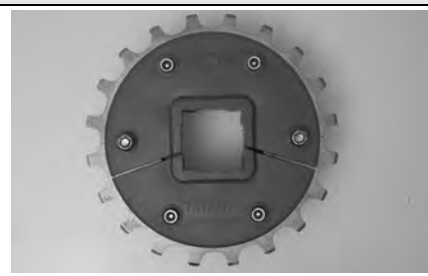

a. Contact Customer Service for lead times.

UHMW Polyethylene Split Sprocket ^a										
No. of Teeth (Chordal Action)	Nom. Pitch Dia. in.	Nom. Pitch Dia. mm	Nom. Outer Dia. in.	Nom. Outer Dia. mm	Nom. Hub Width in.	Nom. Hub Width mm	Available Bore Sizes			
							U.S. Sizes		Metric Sizes	
							Round in.	Square in.	Round mm	Square mm
40 (0.31%)	12.9	328	13.0	330	1.48	38	2-7/16 2-11/16 3-7/16		60	

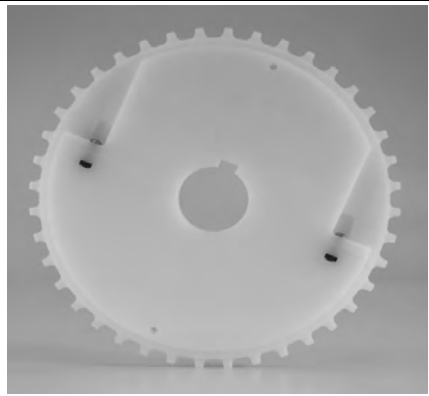

a. Contact Customer Service for lead times.

Nylon FDA Split Sprocket ^a										
No. of Teeth (Chordal Action)	Nom. Pitch Dia. in.	Nom. Pitch Dia. mm	Nom. Outer Dia. in.	Nom. Outer Dia. mm	Nom. Hub Width in.	Nom. Hub Width mm	Available Bore Sizes			
							U.S. Sizes		Metric Sizes	
							Round in.	Square in.	Round mm	Square mm
13 (2.90%)	4.2	107	4.2	107	1.48	38	1-1/4	1-1/2		40
19 (1.38%)	6.1	155	6.1	155	1.48	38	1-1/4	1-1/2		40



a. Contact Customer Service for lead times.

Acetal Sprocket ^a										
No. of Teeth (Chordal Action)	Nom. Pitch Dia. in.	Nom. Pitch Dia. mm	Nom. Outer Dia. in.	Nom. Outer Dia. mm	Nom. Hub Width in.	Nom. Hub Width mm	Available Bore Sizes			
							U.S. Sizes		Metric Sizes	
							Round in.	Square in.	Round mm	Square mm
20 (1.23%)	6.5	165	6.5	165	.75	19		1-1/2		

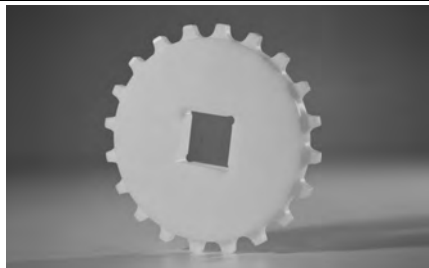

a. Contact Customer Service for lead times.

Enduralox™ Polypropylene Composite Sprocket ^a										
No. of Teeth (Chordal Action)	Nom. Pitch Dia. in.	Nom. Pitch Dia. mm	Nom. Outer Dia. in.	Nom. Outer Dia. mm	Nom. Hub Width in.	Nom. Hub Width mm	Available Bore Sizes			
							U.S. Sizes		Metric Sizes	
							Round in.	Square in.	Round mm	Square mm
20 (1.23%)	6.5	165	6.5	165	1.48	38	2-7/16 3-7/16		90	
25 (0.8%)	8.1	206	8.1	206	1.48	38	2-7/16 3-7/16		90	
40 (0.31%)	12.9	328	13.0	330	1.48	38	2-11/16		60	

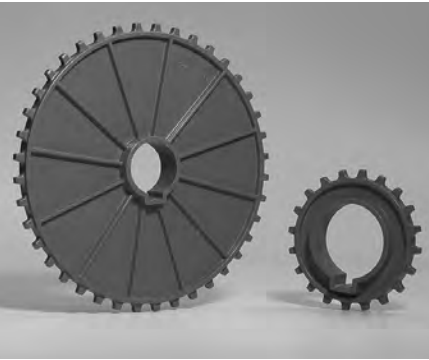

a. Contact Customer Service for lead times.

Flat Top Base Flights (No-Cling)

Available Flight Height		Available Materials
in.	mm	
3	76	Polypropylene, Nylon



Note: Flights can be cut down to custom heights with a minimum height of 0.25 in (13 mm).
Note: Each flight rises out of the center of its supporting module, molded as an integral part. No fasteners are required.
Note: No-Cling vertical ribs are on both sides of the flight.
Note: The minimum indent (without sideguards) is 2.0 in. (50.8 mm).

Conveyor Frame Dimensions

Regardless of type or configuration, all conveyors using Intralox belts have some basic dimensional requirements. Specifically, dimensions “A”, “B”, “C” and “E” listed below should be implemented in any design.

For general applications and applications where end transfer of tip-sensitive product is not critical, use the “A” dimension at the bottom of the range.

Conveyor frame dimensions are established using the top of the roller as the top of the belt and the bottom of the module as the bottom of the belt. “B” dimension is based on a 0.5 in. (12.7 mm) thick carryway.

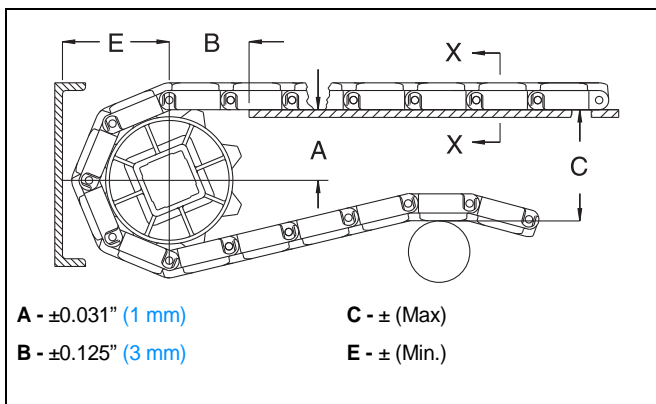

Sprocket Description		A		B		C		E		
Pitch Diameter		No. Teeth	Range (Bottom to Top)		in.	mm	in.	mm	in.	mm
in.	mm		in.	mm						
SERIES 9000 FLUSH GRID										
3.3	84	10	1.30-1.38	33-35	1.65	42	3.26	83	1.95	50
4.2	107	13	1.80-1.86	46-47	1.85	47	4.22	107	2.42	61
6.1	155	19	2.78-2.82	71-72	2.23	57	6.14	156	3.38	86
6.5	165	20	2.94-2.98	75-76	2.35	60	6.46	164	3.54	90
8.1	206	25	3.75-3.78	95-96	2.63	67	8.06	205	4.34	110

Dead Plate Gap

Where there is a transfer point from a belt without finger transfer plates to a dead plate, there should be a gap between the surfaces to allow for the chordal action of the belt. As the belt engages its sprockets, chordal action causes the modules to move past a *fixed* point (the tip of the dead plate) with *varying* clearances. The table below shows the minimum amount of gap which occurs at the “low point” of the modules if the tip of the dead plate just comes in contact with the “high point” as the modules pass.

In some installations it may be desirable to keep the tip of the dead plate in contact with the belt, rather than allow a gap to occur. This can be done by hinging the mounting bracket for the dead plate. This allows the dead plate to move as the modules pass, but results in a small oscillating motion which may present tippage problems for sensitive containers or products.

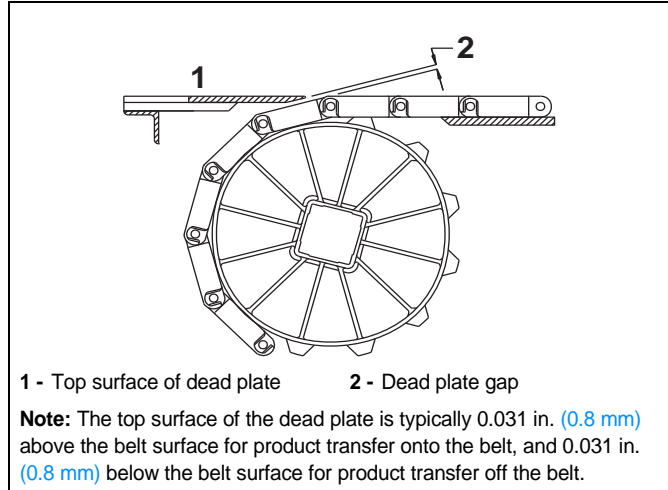

Sprocket Description			Gap	
Pitch Diameter		No. Teeth	in.	mm
in.	mm			
3.3	84	10	0.081	2.1
4.2	107	13	0.061	1.5
6.1	155	19	0.042	1.1
6.5	164	20	0.040	1.0
8.1	205	25	0.032	0.8

Flat Top		
	in	mm
Pitch	3.0	76
Minimum Width	5.9	150
Maximum Width	153.5	3900
Width Increments	0.98	25
Opening Sizes (approx.)	-	-
Open Area	0%	
Hinge Style	Closed	
Drive Method	Center/Hinge-Driven	
Product Notes		
<ul style="list-style-type: none"> • Contact Intralox for precise belt measurements and stock status before designing equipment or ordering a belt. • Smooth, closed upper surface • Available in high-strength electrically-conductive acetal, which has a surface resistivity of 10^5 ohms per square • Available in yellow edges. Staggered yellow edges make it easy to distinguish the moving belt from the stationary floor • Wheel chock attachments are available • Fully flush edges with Slidelox® rod retention feature • Slidelox® is an acetal copolymer • Uses headless rods. 		
Additional Information		
<ul style="list-style-type: none"> • See "Belt Selection Process" (page 5). • See "Standard Belt Materials" (page 9). • See "Special Application Belt Materials" (page 9). 		

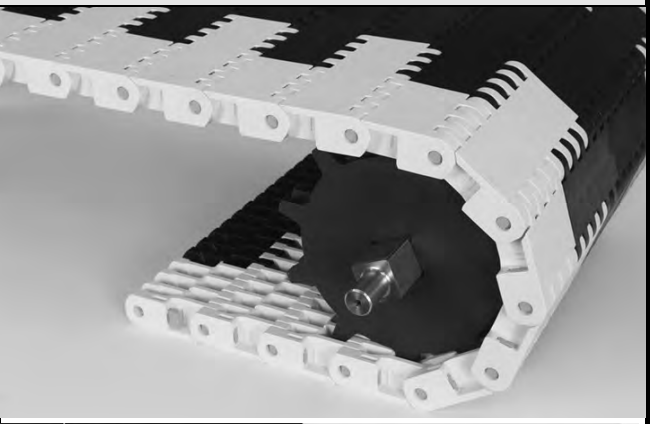
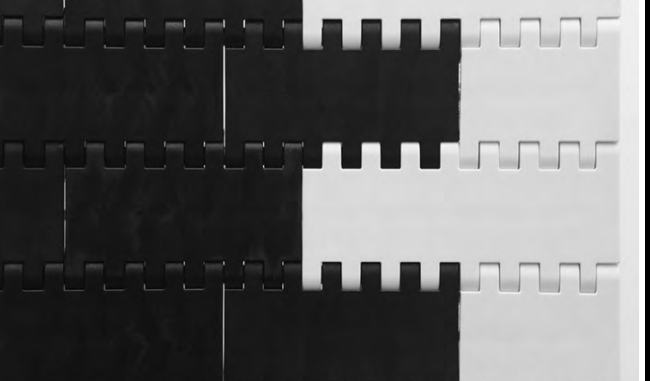
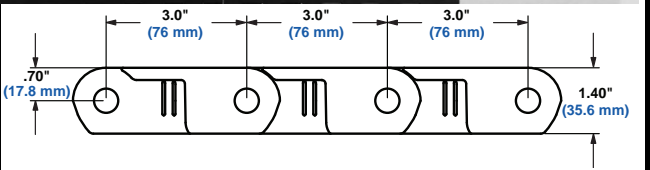
Belt Data							
Belt Material	Standard Rod Material Ø 0.50 in. (12.7 mm)	BS	Belt Strength	Temperature Range (continuous)		W	Belt Weight
			lb/ft	kg/m	°F		°C
Acetal	Nylon	10,000	14,882	-50 to 200	-46 to 93	6.36	31.05
HS EC Acetal	Nylon	8,000	11,905	-50 to 200	-46 to 93	6.36	31.05

Mold to Width Flat Top

	in	mm
Pitch	3.0	76
Molded Widths	3.9	100
	7.9	200
Opening Size (approximate)	-	-
Open Area	0%	
Hinge Style	Closed	
Drive Method	Center/Hinge-Driven	

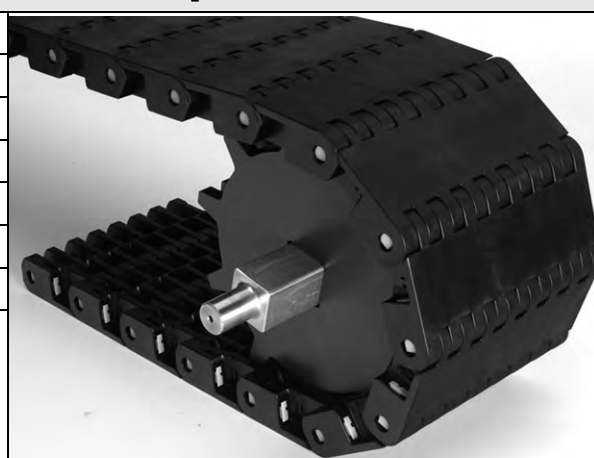

Product Notes

- Contact Intralox for precise belt measurements and stock status before designing equipment or ordering a belt.
- Smooth, closed upper surface.
- Available in high strength electrically conductive acetal, which has a surface resistivity of 10^5 ohms per square.
- Fully flush edges with Slidelox® rod retention feature.
- Slidelox is an acetal copolymer.
- Uses headless rods.

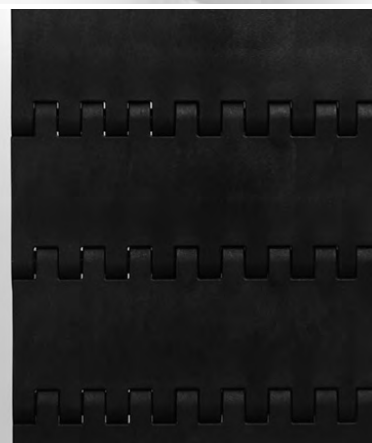

Additional Information

- See "Belt Selection Process" (page 5).
- See "Standard Belt Materials" (page 9).
- See "Special Application Belt Materials" (page 9)

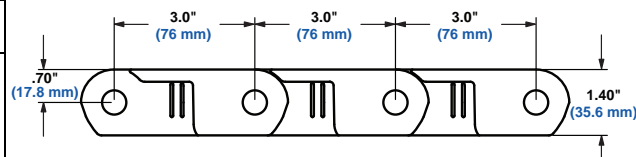

Belt Data

Belt Material	Belt Width		Standard Rod Material Ø 0.50 in (12.7 mm)	BS Belt Strength		Temperature Range (continuous)		W Belt Weight	
	in	mm		lb	kg	°F	°C	lb/ft	kg/m
Acetal	3.9	100	Nylon	2,500	1,134	-50 to 200	-46 to 93	2.08	3.10
Acetal	7.9	200	Nylon	5,800	2,631	-50 to 200	-46 to 93	4.15	6.18
HS EC Acetal	3.9	100	Nylon	2,000	907	-50 to 200	-46 to 93	2.08	3.10
HS EC Acetal	7.9	200	Nylon	4,700	2,132	-50 to 200	-46 to 93	4.15	6.18

Non Skid Raised Rib

	in	mm
Pitch	3.0	76
Minimum Width	5.9	150
Maximum Width	153.5	3900
Width Increments	0.98	25
Opening Sizes (approx.)	-	-
Open Area	0%	
Hinge Style	Closed	
Drive Method	Center/Hinge-Driven	

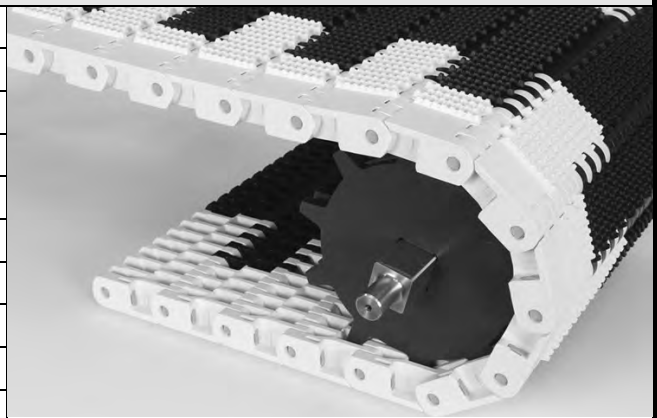

Product Notes

- **Contact Intralox for precise belt measurements and stock status before designing equipment or ordering a belt.**
- Closed upper surface.
- Tread pattern provides a non-skid walking surface to increase safety.
- Available in high strength electrically conductive acetal, which has a surface resistivity of 10^5 ohms per square.
- Available in yellow edges. Staggered yellow edges make it easy to distinguish the moving belt from the stationary floor.
- Wheel chocks are available. Series 10000 Flat Top modules are used to mount the wheel chocks.
- Finger plates are available to shed miscellaneous objects from the surface of the belt.
- Edges have Flat Top surface (no tread pattern). Flat Top indent is 2.0 in (50 mm) from edge of belt.
- Fully flush edges with Slidelox® rod retention feature.
- Slidelox is an acetal copolymer.
- Uses headless rods.

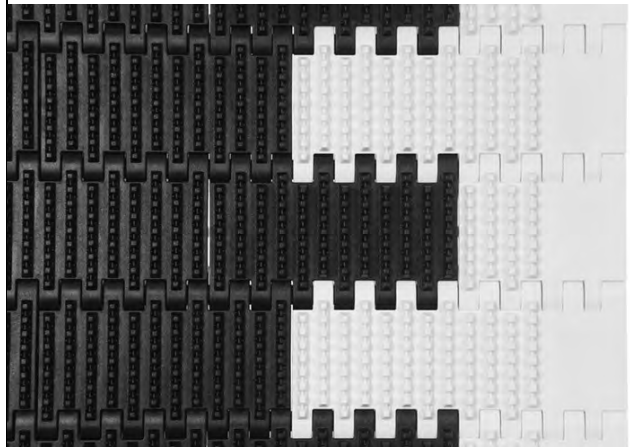

Additional Information

- See "Belt Selection Process" (page 5).
- See "Standard Belt Materials" (page 9).
- See "Special Application Belt Materials" (page 9).

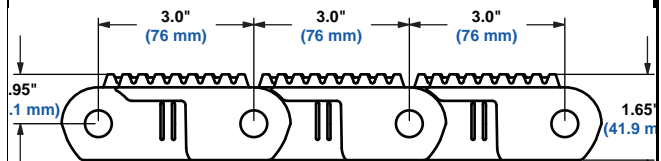

Belt Data

Belt Material	Standard Rod Material Ø 0.50 in (12.7 mm)	BS		Temperature Range (continuous)		W	
		Belt Strength lb./ft.	kg/m	°F	°C	Belt Weight lb./ft. ²	kg/m ²
HS EC Acetal	Nylon	8,000	11,905	-50 to 200	-46 to 93	6.85	33.44

Non Skid Perforated

	in	mm
Pitch	3.00	76.2
Minimum Width	5.9	150
Maximum Width	153.5	3900
Width Increments	.98	25
Opening Sizes (approx.)	0.10 x 0.31	2.8 x 7.9
Open Area	3%	
Hinge Style	Closed	
Drive Method	Center/Hinge-Driven	

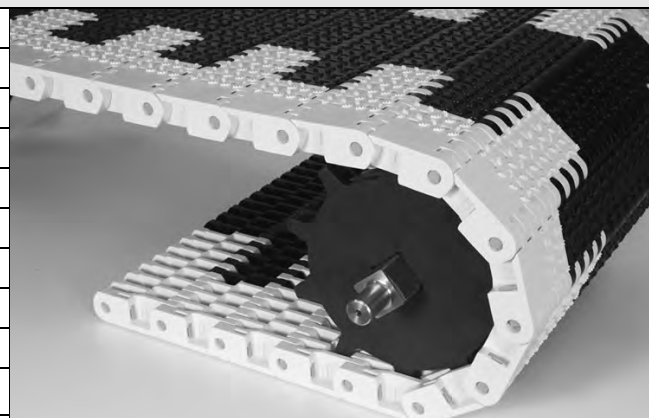

Product Notes

- **Contact Intralox for precise belt measurements and stock status before designing equipment or ordering a belt.**
- Open slots improve drainage. Diamond tread pattern provides a non-skid walking surface to increase safety.
- Available in high strength electrically conductive acetal, which has a surface resistivity of 10^5 ohms per square.
- Available in yellow edges. Staggered yellow edges make it easy to distinguish the moving belt from the stationary floor.
- Wheel chocks are available. Series 10000 Flat Top modules are used to mount the wheel chocks.
- Edges have Flat Top surface (no tread pattern). Flat Top indent is 1.97 in (50.0 mm) from edge of belt.
- Fully flush edges with Slidelox® rod Retention feature
- Slidelox is an acetal copolymer.
- Uses headless rods.

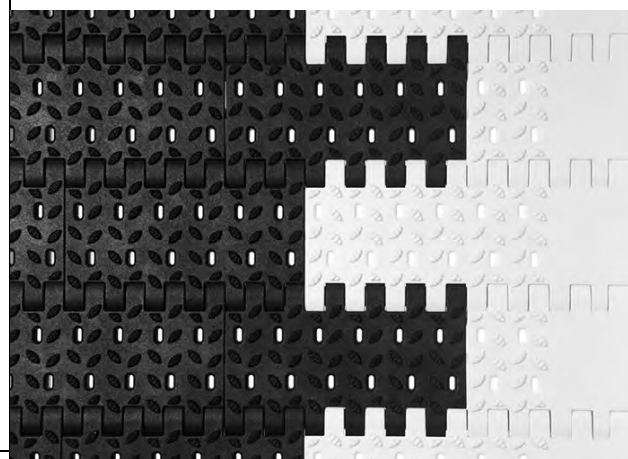

Additional Information

- See "Belt Selection Process" (page 5).
- See "Standard Belt Materials" (page 9).
- See "Special Application Belt Materials" (page 9).

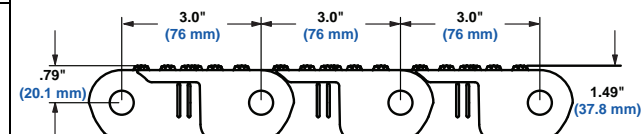

Belt Data

Belt Material	Standard Rod Material Ø 0.50 in (12.7 mm)	BS		Temperature Range (continuous)		W	
		Belt Strength		°F	°C	Belt Weight	
		lb./ft.	kg/m			lb./ft. ²	kg/m ²
Acetal	Nylon	10,000	14,882	-50 to 200	-46 to 93	6.48	31.64
HSEC Acetal	Nylon	8,000	11,905	-50 to 200	-46 to 93	6.48	31.64

Sprocket and Support Quantity Reference				
Belt Width Range ^a		Minimum Number of Sprockets Per Shaft ^b	Wearstrips	
in.	mm		Carryway	Returnway
3	100	1	2	2
5.9	150	1	2	2
7.9	200	2	2	2
9.8	250	2	3	2
11.9	300	3	3	2
13.8	350	3	3	3
15.7	400	3	3	3
17.7	450	3	3	3
19.7	500	3	4	3
23.6	600	5	4	3
29.5	750	5	5	4
31.5	800	5	5	4
35.4	900	7	5	4
41.3	1050	7	6	5
47.2	1200	7	7	5
53.1	1350	9	7	6
59.1	1500	9	8	6
70.9	1800	13	9	7
82.7	2100	21	11	8
94.5	2400	23	12	9
118.1	3000	29	15	11
143.7	3650	35	17	13
145.7	3700	37	18	14
147.6	3750	37	18	14
149.6	3800	37	18	14
151.6	3850	37	18	14
153.5	3900	41	19	14
For Other Widths, Use Odd Number of Sprockets ^c at Maximum 6 in. (152 mm) \varnothing Spacing			Maximum 6 in. (152 mm) \varnothing Spacing	Maximum 12 in. (305 mm) \varnothing Spacing

- If your belt width exceeds a number listed in the table, please refer to the sprocket and support material minimums for the next larger width range listed. Belts are available in 1.97 in. (50 mm) increments beginning with a minimum width of 3.94 in. (100 mm). **If the actual width is critical, consult Customer Service.**
- These are the minimum number of sprockets. Additional sprockets may be required for heavily loaded applications. Sprockets require a maximum 5.91 in. (150 mm) centerline spacing.
- The center sprocket should be locked down. With only two sprockets, fix the sprocket on the drive journal side only. See Retainer Rings/Center Sprocket Offset chart on page 410 for lock down location.

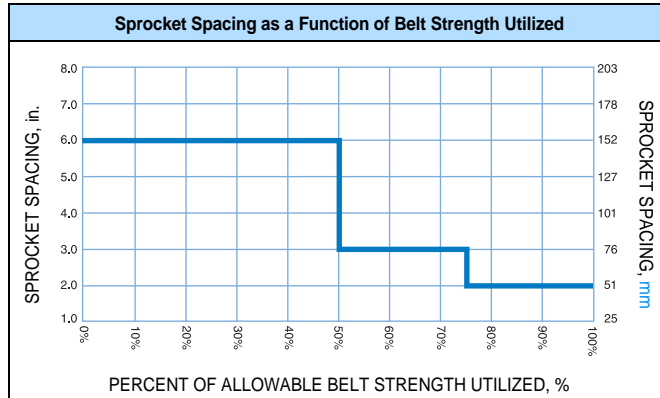
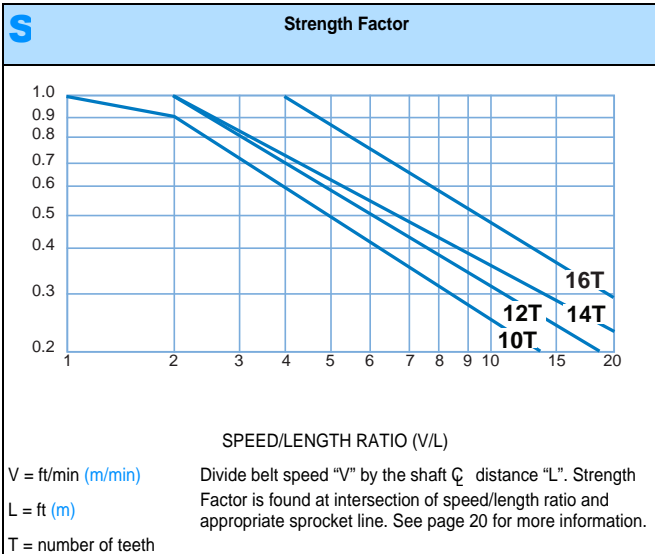

Nylon Sprocket^a

No. of Teeth (Chordal Action)	Nom. Pitch Dia. in	Nom. Pitch Dia. mm	Nom. Outer Dia. in	Nom. Outer Dia. mm	Nom. Hub Width in	Nom. Hub Width mm	Available Bore Sizes			
							U.S. Sizes		Metric Sizes	
							Round in	Square in	Round mm	Square mm
10 (4.70%)	9.9	251	9.7	246	1.5	38		3.5		90
12 (3.29%)	11.8	300	11.7	297	1.5	38		3.5		90
14 (2.43%)	13.7	348	13.6	345	1.5	38		3.5		90
16 (1.84%)	15.7	399	15.6	396	1.5	38		3.5	100 120 140	90

a. Contact Customer Service for lead times.

Flat Top Wheel Chock and Side Wheel Chock

Available Height		Available Width		Available Materials
in	mm	in	mm	
0.8	20	1.5	37	Nylon
1.6	40	4.9	125	Nylon
2	50	4.9	125	Nylon

Note: Fasteners and modified S10000 Flat Top modules are required.
Note: The minimum indent (without wheel chocks) is 2.0 in (50 mm).

Insert Nuts

Available Base Belt Style - Material	Available Insert Nut Sizes	
Series 10000 Flat Top - Acetal	<p>6 mm–1 mm</p> <p>8 mm–1.25 mm</p>	

Note: Insert Nuts easily allow the attachment of fixtures to the belt.

Note: Attachments that are connected to more than one row must not prohibit the rotation of the belt around the sprockets.

Note: The fastener torque specification is 40-45 in-lb (4.5-5.0 N-m).

Note: Square insert nuts are provided. The square flange ensures that the insert nut stays in place when the bolt is tightened or loosened.

Note: Sprockets can be located in-line with insert nuts if a 0.187 (4.75 mm) clearance is maintained. Contact Intralox Customer Service for the appropriate bolt length to fit the application.

Note: Nut placement constraints are as follows: 1.22" (31 mm) minimal indent from the edge of the belt, .492" (12.5 mm) minimal distance between nuts across the width of the belt and spacing along the length of the belt is in 3" (76 mm) increments.

Note: All nut placement dimensions are referenced from the edge of the belt when placing an order. Contact Intralox Customer Service for nut location options available for your individual belt specifications.

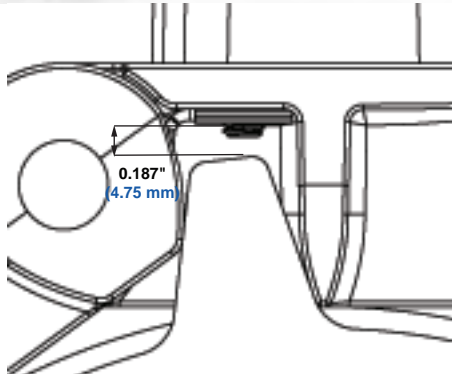

Finger Transfer Plates

Available Widths		Number of Fingers	Available Materials
in	mm		
5.9	150	12	Acetal

Note: The fingers extend between the belt ribs to prevent hardware from dropping off the end of the conveyor.

Note: Easily installed on the conveyor frame.

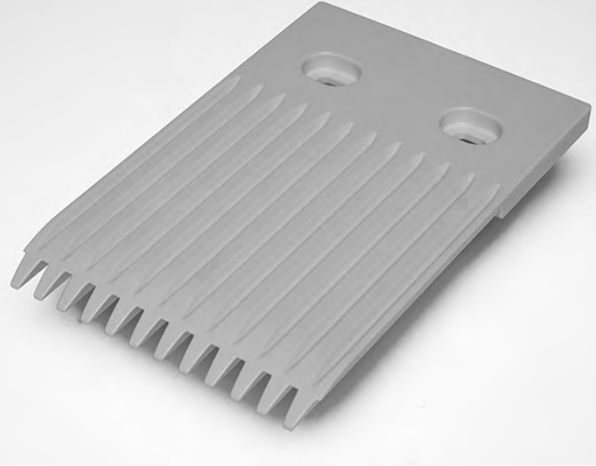

Conveyor Frame Dimensions

Regardless of type or configuration, all conveyors using Intralox belts have some basic dimensional requirements. Specifically, dimensions "A", "B", "C" and "E" listed below should be implemented in any design.

For general applications and applications where end transfer of tip-sensitive product is not critical, use the "A" dimension at the bottom of the range.

Conveyor frame dimensions are established using the top of the roller as the top of the belt and the bottom of the module as the bottom of the belt. "B" dimension is based on a 0.5 in. (12.7 mm) thick carryway.

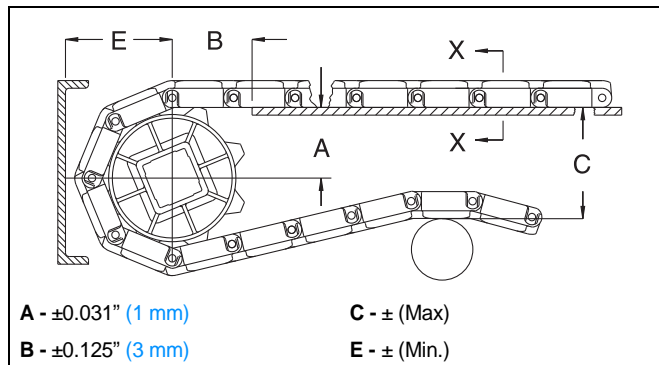

Sprocket Description			A		B		C		E	
Pitch Diameter		No. Teeth	Range (Bottom to Top)		in.	mm	in.	mm	in.	mm
in.	mm		in.	mm						
FLAT TOP										
9.9	251	10	4.02-4.25	102-108	3.33	85	9.90	251	5.71	145
11.8	300	12	5.01-5.20	127-132	3.73	95	11.80	300	6.66	169
13.7	348	14	5.98-6.15	152-156	4.03	102	13.70	348	7.61	193
15.7	399	16	7.01-7.15	178-182	4.33	110	15.70	399	8.61	219
NON SKID RAISED RIB										
9.9	251	10	4.02-4.25	102-108	3.33	85	10.15	258	5.96	151
11.8	300	12	5.01-5.20	127-132	3.73	95	12.05	306	6.91	176
13.7	348	14	5.98-6.15	152-156	4.03	102	13.95	354	7.86	200
15.7	399	16	7.01-7.15	178-182	4.33	110	15.95	405	8.86	225
NON SKID PERFORATED										
9.9	251	10	4.02-4.25	102-108	3.33	85	9.99	254	5.80	147
11.8	300	12	5.01-5.20	127-132	3.73	95	11.89	302	6.75	171
13.7	348	14	5.98-6.15	152-156	4.03	102	13.79	350	7.70	196
15.7	399	16	7.01-7.15	178-182	4.33	110	15.79	401	8.70	221

Dead Plate Gap

Where there is a transfer point from a belt without finger transfer plates to a dead plate, there should be a gap between the surfaces to allow for the chordal action of the belt. As the belt engages its sprockets, chordal action causes the modules to move past a *fixed* point (the tip of the dead plate) with *varying* clearances. The table below shows the minimum amount of gap which occurs at the “low point” of the modules if the tip of the dead plate just comes in contact with the “high point” as the modules pass.

In some installations it may be desirable to keep the tip of the dead plate in contact with the belt, rather than allow a gap to occur. This can be done by hinging the mounting bracket for the dead plate. This allows the dead plate to move as the modules pass, but results in a small oscillating motion which may present tippage problems for sensitive containers or products.

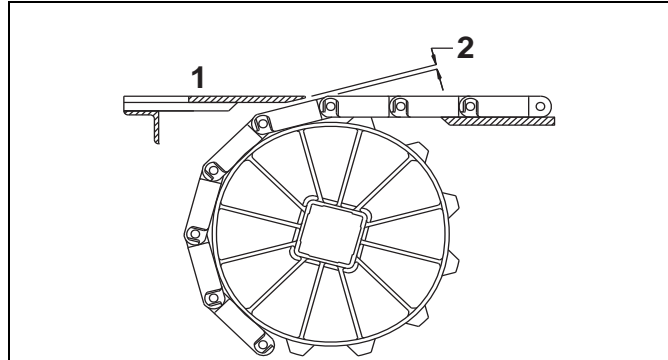

1 - Top surface of dead plate 2 - Dead plate gap

Note: The top surface of the dead plate is typically 0.031 in. (0.8 mm) above the belt surface for product transfer onto the belt, and 0.031 in. (0.8 mm) below the belt surface for product transfer off the belt.

Sprocket Description		Gap		
Pitch Diameter		No. Teeth	in.	mm
in.	mm			
9.9	251	10	0.233	5.9
11.8	300	12	0.194	4.9
13.7	348	14	0.166	4.2
15.7	399	16	0.145	3.7

ZERO TANGENT™ Radius Flat Top

	in	mm
Row to Row Angle	1.33 degrees	
Maximum Width	55.12	1400
Minimum Width	7.87	200
Width Increments	7.87	200
Open Area	0%	
Hinge Style	Closed	
Drive Method	Center/Hinge-Driven	

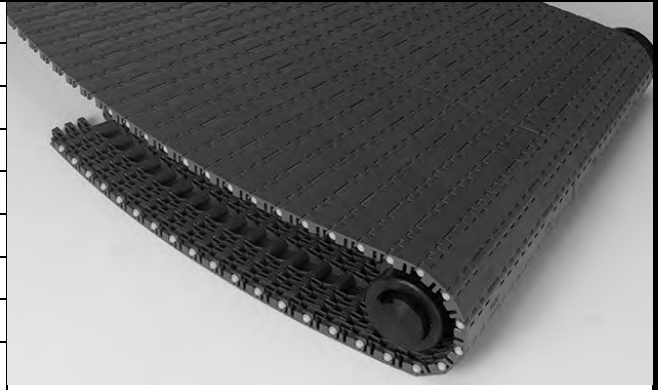

Product Notes

- **Contact Intralox for precise belt measurements and stock status before designing equipment or ordering a belt.**
- Designed for radius applications with a minimum inside turn radius of 23.62 in (600 mm).
- Belt shape requires zero straight sections before and after turn.
- Pitch distance changes depending upon location of module from center of turn.
- Complete design guideline packages supplied to minimize engineering design investment.
- Row to row angle is nominally 1.33 degrees around center of turn.
- Uses headed rodlets with nylon rods.



Additional Information

- See "Belt Selection Process" (page 5)
- See "Standard Belt Materials" (page 9)
- See "Special Application Belt Materials" (page 9)
- See "Friction Factors" (page 13)

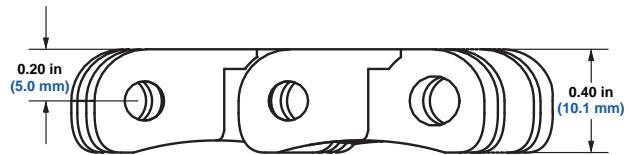

Belt Data



Belt Material	Standard Rod Material Ø 0.180 in (4.6 mm)	BS Belt Strength		Temperature Range (continuous)		W Belt Weight	
		lb/ft	kg/m	°F	°C	lb/ft ²	kg/m ²
Acetal	Nylon	907	1350	-50 to 200	-46 to 93	1.89	9.25

Sprocket and Support Quantity Reference				
Belt Width Range ^a		Minimum Number of Sprockets Per Shaft ^b	Wearstrips	
in	mm		Carryway	Returnway
7.87	200	2	2	2
15.75	400	4	3	2
23.62	600	6	4	2
31.50	800	8	5	3
39.37	1000	10	6	3

For other widths, use even number of sprockets at Maximum sprocket spacing: 3.94 in (100 mm)
Maximum carryway spacing: 7.87 in (200 mm) • Maximum returnway spacing: 15.75 in (400 mm)

- a. If the actual width is critical, consult Customer Service.
b. All sprockets should be locked down.

Nylon Sprocket ^{ab}											
No. of Teeth (Chordal Action)	Nom. Pitch Dia. in	Nom. Pitch Dia. mm	Nom. Outer Dia. in	Nom. Outer Dia. mm	Nom. Hub Width in	Nom. Hub Width mm	Available Bore Sizes				
							U.S. Sizes		Metric Sizes		
							Round in	Square in	Round mm	Square mm	
12 (3.41%)	2.3	58	2.4	61	1.0	25	1-7/16	-	40	-	
12 (3.41%)	2.6	66	2.7	69	1.0	25	1-7/16	-	40	-	
12 (3.41%)	3.0	76	3.1	79	1.0	25	1-7/16	-	40	-	
12 (3.41%)	3.3	84	3.4	86	1.0	25	1-7/16	-	40	-	
12 (3.41%)	3.7	94	3.8	97	1.0	25	1-7/16	-	40	-	
12 (3.41%)	4.0	102	4.1	104	1.0	25	1-7/16	-	40	-	
12 (3.41%)	4.4	112	4.5	114	1.0	25	1-7/16	-	40	-	
12 (3.41%)	4.7	119	4.8	122	1.0	25	1-7/16	-	40	-	
12 (3.41%)	5.1	130	5.2	132	1.0	25	1-7/16	-	40	-	
12 (3.41%)	5.4	137	5.5	140	1.0	25	1-7/16	-	40	-	
12 (3.41%)	5.8	147	5.8	147	1.0	25	1-7/16		40		
12 (3.41%)	6.2	157	6.2	157	1.0	25	1-7/16		40		
12 (3.41%)	6.5	165	6.5	165	1.0	25	1-7/16		40		
12 (3.41%)	6.9	175	6.9	175	1.0	25	1-7/16		40		

- a. Contact Customer Service for lead times.
b. Sprockets are made of non-FDA nylon.

Conveyor Frame Dimensions

Regardless of type or configuration, all conveyors using Intralox belts have some basic dimensional requirements. Specifically, dimensions “A”, “B”, “C”, and “E” listed below should be implemented in any design.

For general applications and applications where end transfer of tip-sensitive product is not critical, use the “A” dimension at the bottom of the range.

Conveyor frame dimensions are established using the top of the roller as the top of the belt and the bottom of the module as the bottom of the belt. “B” dimension is based on a 0.5 in (12.7 mm) thick carryway.

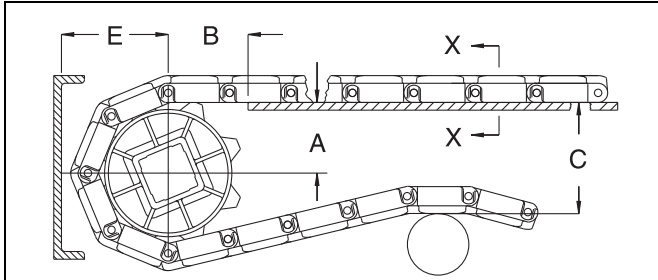

- A - ±0.031 in (1 mm)
- B - ±0.125 in (3 mm)
- C - ± (Max)
- E - ± (Min)

Complete descriptions of the dimensions are listed on page 423.

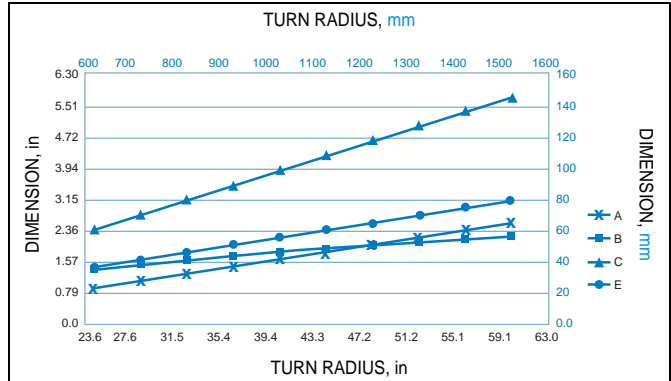

Dim A = 0.043TR-0.20 in (-5 mm) Dim B = 0.022TR+0.82 in (+20 mm)
 Dim C = 0.089TR-0.01 in (-25 mm) Dim E = 0.045TR+0.26 in (+6 mm)
 TR = Turn Radius

Dead Plate Gap

Where there is a transfer point from a belt without finger transfer plates to a dead plate, there should be a gap between the surfaces to allow for the chordal action of the belt. As the belt engages its sprockets, chordal action causes the modules to move past a *fixed* point (the tip of the dead plate) with *varying* clearances. The table below shows the minimum amount of gap which occurs at the “low point” of the modules if the tip of the dead plate just comes in contact with the “high point” as the modules pass.

In some installations, it may be desirable to keep the tip of the dead plate in contact with the belt rather than allow a gap to occur. This can be done by hinging the mounting bracket for the dead plate. This allows the dead plate to move as the modules pass, but results in a small oscillating motion which may present tippage problems for sensitive containers or products.

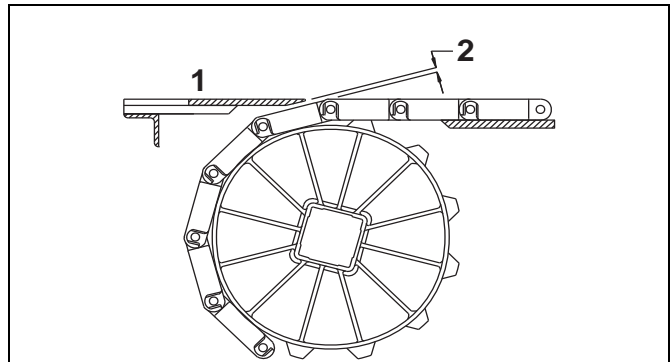

- 1 - Top surface of dead plate
- 2 - Dead plate gap

Note: The top surface of the dead plate is typically 0.031 in = (0.8 mm) above the belt surface for product transfer onto the belt, and 0.031 in (0.8 mm) below the belt surface for product transfer off the belt.

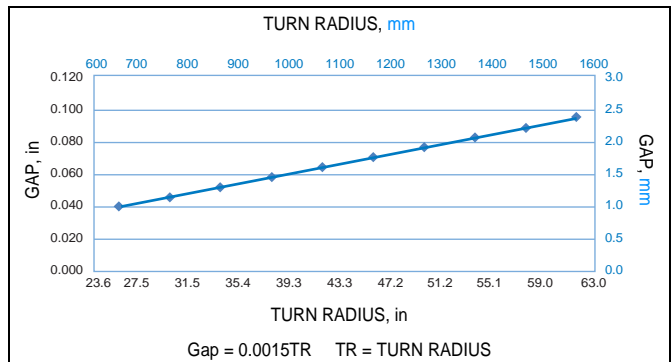

Gap = 0.0015TR TR = TURN RADIUS

Radius Flush Grid		
	in	mm
Pitch	1.50	38.1
Minimum Width	5	127
Width Increments	1.00	25.4
Opening Size (approximate)	0.50 × 0.75	12.7 × 19.7
Open Area	50%	
Product Contact Area	37%	
Hinge Style	Open	
Drive Method	Hinge-driven	



Product Notes	
<ul style="list-style-type: none"> Contact Intralox for precise belt measurements and stock status before designing equipment or ordering a belt. Flush edge or tab edge available. Uses headless rods. Designed for radius applications with a minimum turn radius of 2.2 times belt width (measured from inside edge). Lightweight, relatively strong belt with smooth surface grid. Belt openings pass straight through belt, making it easy to clean. Non-sliding drive system for reduced belt and sprocket wear, and for low back-side tension. Tab edge belt width is measured exclusive of tabs. (Tabs extend approx. 0.5 in (13 mm) × 0.25 in (6 mm) thick on each side of belt, inside wearstrip.) Maximum belt width in turns is 36 in (914 mm) <p>WARNING: Do not place fingers in or on this belt. Fingers can get trapped in belt openings, resulting in personal injury. This belt has pinch points due to the belt spreading and collapsing as it flexes to follow the conveyor path. Pinch points can trap fingers, hair, or clothing, causing personal injury. Do not wear loose clothing, loose gloves, or hand/finger jewelry when working near this belt. Call Customer Service for tags, flyers, and stickers containing this warning.</p>	

Additional Information

- See "Belt Selection Process" (page 5)
- See "Standard Belt Materials" (page 9)
- See "Special Application Belt Materials" (page 9)
- See "Friction Factors" (page 13)

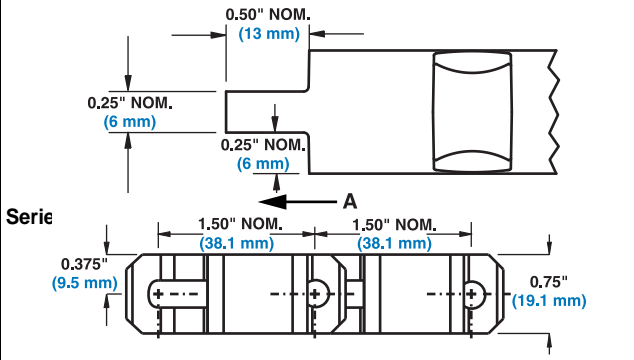

A - Preferred direction for flat turning applications

Belt Data								
Belt Material	Standard Rod Material Ø 0.24 in (6.1 mm)	BS Straight Belt Strength		Curved Belt Strength	Temperature Range (continuous)		W Belt Weight	
					°F	°C		
Polypropylene	Acetal	1600	2380	Contact Intralox Customer Service for curved belt strength calculations.	34 to 200	1 to 93	1.86	9.10
Polyethylene ^a	Acetal	1000	1490		-50 to 150	-46 to 66	1.96	9.56
Acetal	Nylon	2500	3720		-50 to 200	-46 to 93	2.82	13.80
Polypropylene	Polypropylene ^b	1400	2100		34 to 220	1 to 104	1.78	8.69

a. Polyethylene cannot exceed 150 °F (66 °C)
 b. Polypropylene rods can be installed in polypropylene belts when extra chemical resistance is required. Please note lower belt strength.

Radius Flush Grid High Deck

	in	mm
Pitch	1.50	38.1
Minimum Width	6	152
Width Increments	1.00	25.4
Opening Size (approximate)	0.50 × 0.75	12.7 × 19.7
Open Area	50%	
Product Contact Area	37%	
Hinge Style	Open	
Drive Method	Hinge-driven	



Product Notes

- Contact Intralox for precise belt measurements and stock status before designing equipment or ordering a belt.
- Flush Grid High Deck is 0.5 in (12.7 mm) higher than the standard Series 2200 belt.
- Uses headless rods.
- Makes turns with an inside radius of 2.2 times the belt width.
- Flush Grid High Deck has more beam strength than the standard Series 2200 belt, which can reduce retrofit costs in spirals.
- Works with standard Series 2200 wearstrips.
- Standard indent for Flush Grid High Deck is 1.25 in (31.8 mm)

WARNING: Do not place fingers in or on this belt. Fingers can get trapped in belt openings, resulting in personal injury. This belt has pinch points due to the belt spreading and collapsing as it flexes to follow the conveyor path. Pinch points can trap fingers, hair, or clothing, causing personal injury. Do not wear loose clothing, loose gloves, or hand/finger jewelry when working near this belt. Call Customer Service for tags, flyers, and stickers containing this warning.

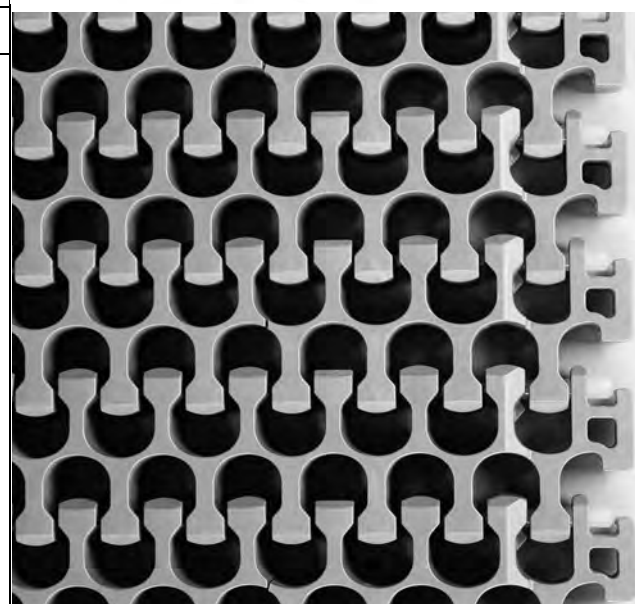

Additional Information

- See "Belt Selection Process" (page 5)
- See "Standard Belt Materials" (page 9)
- See "Special Application Belt Materials" (page 9)
- See "Friction Factors" (page 13)

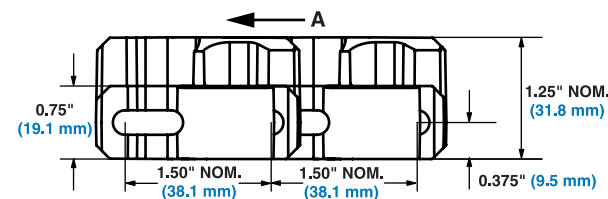

A -Preferred direction for flat turning applications

Belt Data

Belt Material	Standard Rod Material Ø 0.24 in (6.1 mm)	BS	Straight Belt Strength ^a	Curved Belt Strength	Temperature Range (continuous)		W	Belt Weight
					°F	°C		
Acetal	Nylon	2500	3720	Contact Intralox Customer Service for curved belt strength calculations.	-50 to 200	-46 to 93	3.66	17.87

a. When using polyurethane sprockets, the Belt Strength for belts rated over 750 lb/ft (1120 kg/m) will be de-rated to 750 lb/ft (1120 kg/m) and all other belts will maintain their published rating. The temperature range for polyurethane sprockets is 0 °F (-18 °C) to 120 °F (49 °C). Contact Customer Service for availability of polyurethane sprockets.

Radius Friction Top		
	in	mm
Pitch	1.50	38.1
Minimum Width	5	127
Width Increments	1.00	25.4
Opening Size (approximate)	0.50 x 0.75	12.7 x 19.7
Open Area	50%	
Hinge Style	Open	
Drive Method	Hinge-driven	

Product Notes

- Contact Intralox for precise belt measurements and stock status before designing equipment or ordering a belt.
- Flush edge or tab edge available.
- Uses headless rods.
- Designed for radius applications with a minimum turn radius of 2.2 times belt width (measured from inside edge).
- Indent is molded at 1.75 in (44.5 mm)
- Friction top available in grey PP with grey rubber, white PP with white rubber, and natural PE with white rubber.
- Belt openings pass straight through belt, making it easy to clean.
- Non-sliding drive system for reduced belt and sprocket wear, and for low back-side tension.
- Tab edge belt width is measured exclusive of tabs. (Tabs extend approx. 0.5 in (13 mm) x 0.25 in (6 mm) thick on each side of belt, inside wearstrip.)
- Maximum belt width in turns is 36 in (914 mm)
- Temperature, environmental conditions, and product characteristics affect the effective maximum degree of incline. Take these items into consideration when designing conveyor systems utilizing these belts.

WARNING: Do not place fingers in or on this belt. Fingers can get trapped in belt openings, resulting in personal injury. This belt has pinch points due to the belt spreading and collapsing as it flexes to follow the conveyor path. Pinch points can trap fingers, hair, or clothing, causing personal injury. Do not wear loose clothing, loose gloves, or hand/finger jewelry when working near this belt. Call Customer Service for tags, flyers, and stickers containing this warning.

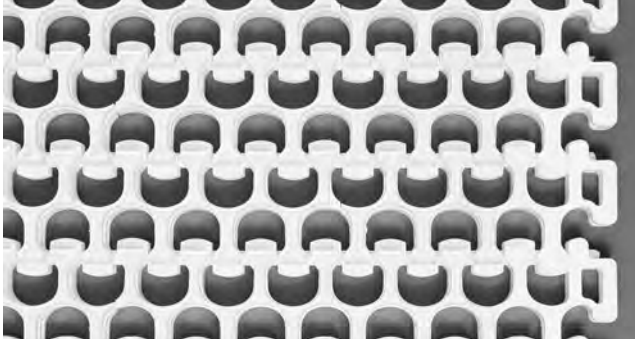
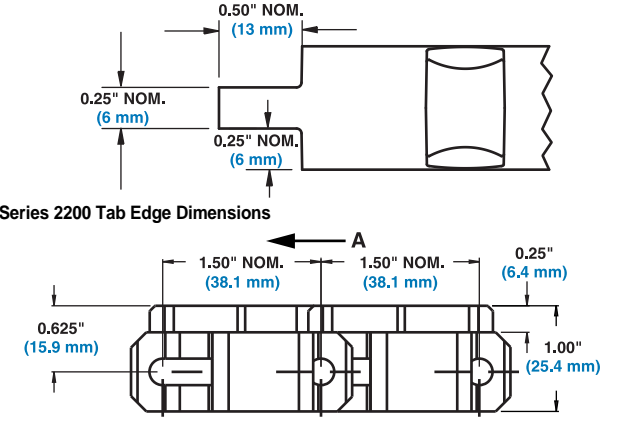
Series 2200 Tab Edge Dimensions

A - Preferred direction for flat turning applications

Additional Information		
<ul style="list-style-type: none"> • See "Belt Selection Process" (page 5) • See "Standard Belt Materials" (page 9) • See "Special Application Belt Materials" (page 9) • See "Friction Factors" (page 13) 		

Belt Data												
Base Belt Material	Base/Friction Color	Standard Rod Material Ø 0.24 in (6.1 mm)	BS Belt Strength		Curved Belt Strength	Temperature Range (continuous)		W Belt Weight		Friction Top Hardness	Agency Acceptability	
						°F	°C				lb/ft ²	kg/m ²
Polypropylene	Grey/Grey	Acetal	1600	2380	Contact Intralox Customer Service for curved belt strength calculations.	34 to 150	1 to 66	2.20	10.74	64 Shore A		
Polypropylene	White/White	Acetal	1600	2380		34 to 150	1 to 66	2.20	10.74	55 Shore A	a	c
Polyethylene	Natural/White	Acetal	1000	1490		-50 to 120	-46 to 49	2.30	11.23	55 Shore A	a	c
Polypropylene	Grey/Grey	Polypropylene	1400	2100		34 to 150	1 to 66	2.12	10.35	64 Shore A		
Polypropylene	White/White	Polypropylene	1400	2100		34 to 150	1 to 66	2.12	10.35	55 Shore A	a	c

• - Fully compliant

a - FDA Compliant with Restriction: Do not use in direct contact with fatty foods.

b - European Migration Certificate providing approval for food contact according to EU Regulation 10/2011.

c - EU compliant with Restriction: Do not use in direct contact with fatty foods.

Radius with Edge Bearing

	in	mm
Pitch	1.50	38.1
Minimum Width (Bearings one side)	7	178
Minimum Width (Bearings both sides)	9	229
Width Increments	1.00	25.4
Opening Size (approximate)	0.50 x 0.75	12.7 x 19.7
Open Area	50%	
Product Contact Area	37%	
Hinge Style	Open	
Drive Method	Hinge-driven	

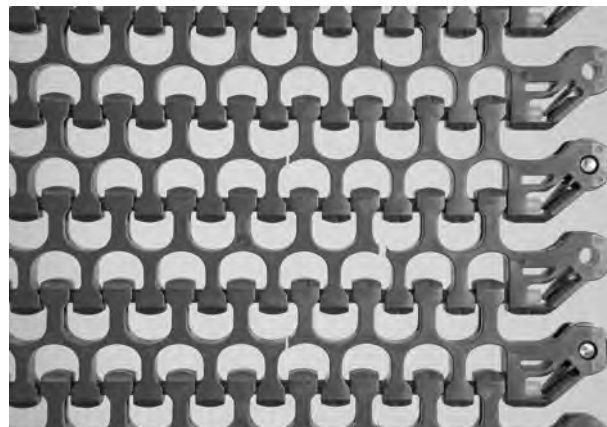

Product Notes

- **Contact Intralox for precise belt measurements and stock status before designing equipment or ordering a belt.**
- Edge Bearings are only available for turning belts.
- Bearings must be placed on the inside edge of the turn.
- Bearings are available on one side for belts that turn in only one direction or on both sides for belts that turn in both directions.
- Both flush edge and tab edge are available for belts that have bearings on only one side and must be placed on the outside edge of the turn.
- Bearings must be configured in every other row of the belt.
- Bearings are chrome steel, recommended for dry applications only.
- The plastic portion of the bearing edge is indented 0.125 in (3.2 mm). Belt width is measured to the end of the bearing.
- Bearings are retained in the belt using a stainless pin.
- Rod retention allows for easier insertion and removal of rods.
- Uses headless rods.
- Designed for radius applications with a minimum turn radius of 2.2 times the belt width (measured from the inside edge of the wearstrip channel).
- Maximum belt width is 36 in (914 mm).
- Maximum belt speed is 350 fpm (107 meters per minute).
- Belts with bearings on one side work with standard edge, hold down wearstrips with a 0.50 in (12.7 mm) deep channel.
- Belts with bearings on both sides require the wearstrip on the outside of the turns to have at least a 0.75 in (19.1 mm) deep channel.
- The Intralox Engineering Program should be used to determine if the Edge Bearing is suitable for your application.

WARNING: Do not place fingers in or on this belt. Fingers can get trapped in belt openings, resulting in personal injury. This belt has pinch points due to the belt spreading and collapsing as it flexes to follow the conveyor path. Pinch points can trap fingers, hair, or clothing, causing personal injury. Do not wear loose clothing, loose gloves, or hand/finger jewelry when working near this belt. Call Customer Service for tags, flyers, and stickers containing this warning.

Additional Information

- See "Belt Selection Process" (page 5)
- See "Standard Belt Materials" (page 9)
- See "Special Application Belt Materials" (page 9)
- See "Friction Factors" (page 13)

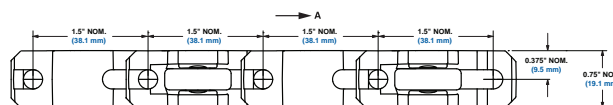

A - Preferred direction for flat turning applications

Belt Data

Belt Material	Standard Rod Material Ø 0.24 in (6.1 mm)	BS	Straight Belt Strength	Curved Belt Strength	Temperature Range (continuous)		W	Belt Weight
					°F	°C		
Acetal	Nylon	2000	2976	Contact Intralox Customer Service for curved belt strength calculations.	-50 to 200	-46 to 93	2.82	13.80

Flush Grid High Deck with Edge Bearing

	in	mm
Pitch	1.50	38.1
Minimum Width (Bearings one side)	7.0	177.8
Minimum Width (Bearings both sides)	9.0	228.6
Width Increments	1.0	25.4
Opening Size (approximate)	0.50 x 0.75	12.7 x 19.7
Open Area	50%	
Product Contact Area	37%	
Hinge Style	Open	
Drive Method	Hinge-driven	



Product Notes

- **Contact Intralox for precise belt measurements and stock status before designing equipment or ordering a belt.**
- Edge Bearings are only available for turning belts.
- Bearings must be placed on the inside edge of the turn.
- Bearings are available on one side for belts that turn in only one direction or on both sides for belts that turn in both directions.
- Flush Grid High Deck is 0.5 in (12.7 mm) higher than the standard Series 2200 belt.
- Standard Indent for Flush Grid High Deck with Edge Bearing is 1.75 in (44.5 mm).
- Bearings must be configured in every other row of the belt.
- Bearings are chrome steel, recommended for dry applications only.
- The plastic portion of the bearing edge is indented .125 in (3.2 mm). Belt width is measured to the end of the bearing.
- Bearings are retained in the belt using a stainless pin.
- Rod retention allows for easier insertion and removal of rods.
- Uses headless rods.
- Designed for radius applications with a minimum turn radius of 2.2 times the belt width (measured from the inside edge of the wearstrip channel).
- Maximum belt width is 36 in (914 mm).
- Maximum belt speed is 350 fpm (107 meters per minute).
- Belts with bearings on one side work with standard edge, hold down wearstrips with a 0.50 in (12.7 mm) deep channel.
- Belts with bearings on both sides require the wearstrip on the outside of the turns to have at least a 0.75 in (19.1 mm) deep channel.
- The Intralox Engineering Program should be used to determine if the Edge Bearing is suitable for your application.

WARNING: Do not place fingers in or on this belt. Fingers can get trapped in belt openings, resulting in personal injury. This belt has pinch points due to the belt spreading and collapsing as it flexes to follow the conveyor path. Pinch points can trap fingers, hair, or clothing, causing personal injury. Do not wear loose clothing, loose gloves, or hand/finger jewelry when working near this belt. Call Customer Service for tags, flyers, and stickers containing this warning.

Additional Information

- See "Belt Selection Process" (page 5)
- See "Standard Belt Materials" (page 9)
- See "Special Application Belt Materials" (page 9)
- See "Friction Factors" (page 13)

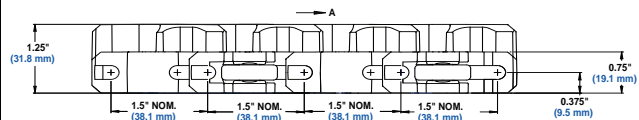
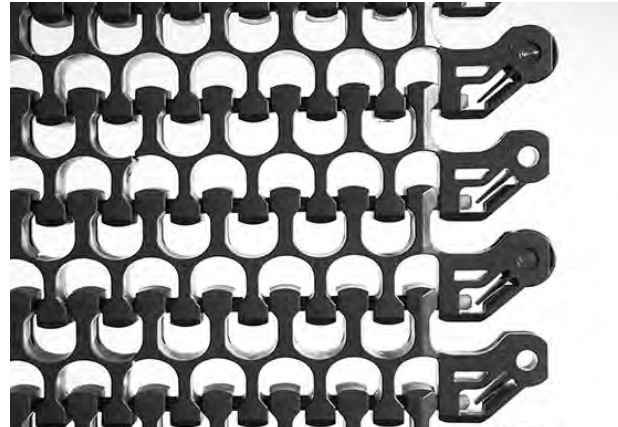

A - Preferred direction for flat turning applications

Belt Data

Belt Material	Standard Rod Material Ø 0.24 in (6.1 mm)	BS Straight Belt Strength		Curved Belt Strength	Temperature Range (continuous)		W Belt Weight	
		lb/ft	kg/m		°F	°C	lb/ft ²	kg/m ²
Acetal	Nylon	2000	2976	Contact Intralox Customer Service for curved belt strength calculations.	-50 to 200	-46 to 93	3.66	17.87

Radius Flush Grid (2.6) with Insert Rollers

	in	mm
Pitch	1.50	38.1
Minimum Width	7	178
Width Increments	1.00	25.4
Opening Size (approximate)	0.50 x 0.75	12.7 x 19.7
Open Area	50%	
Hinge Style	Open	
Drive Method	Hinge-driven	



Product Notes

- Contact Intralox for precise belt measurements and stock status before designing equipment or ordering a belt.
- For applications where low back pressure accumulation is required.
- Flush edge or tabbed edge available.
- Uses headless rods.
- Acetal rollers
- Standard roller spacings across belt width: staggered - 4 in (102 mm) or inline - 2 in (51 mm), 3 in (76 mm), or 4 in (102 mm).
- Standard roller spacings along belt length: staggered - 1.5 in (38.1 mm) or inline - 3 in (76.2 mm).
- Minimum 2.5 in (63.5 mm) roller indent.
- Contact Customer Service for non-standard roller placement options.
- Sprockets must NOT be placed inline with rollers.
- For low back pressure applications, place wearstrip between rollers. For driven applications, place wearstrip directly under rollers.
- Back-up load is 5% to 10% of product weight.
- Tab edge belt width is measured exclusive of tabs. (Tabs extend approx. 0.5 in (13 mm) x 0.25 in (6 mm) thick on each side of belt, inside wearstrip.)
- Due to roller placement, the turn radius increases to 2.6. Belts 16 in (406 mm) wide and less have a turn ratio of 2.2.
- Contact Sales Engineering before using a belt width greater than 24 in (610 mm).

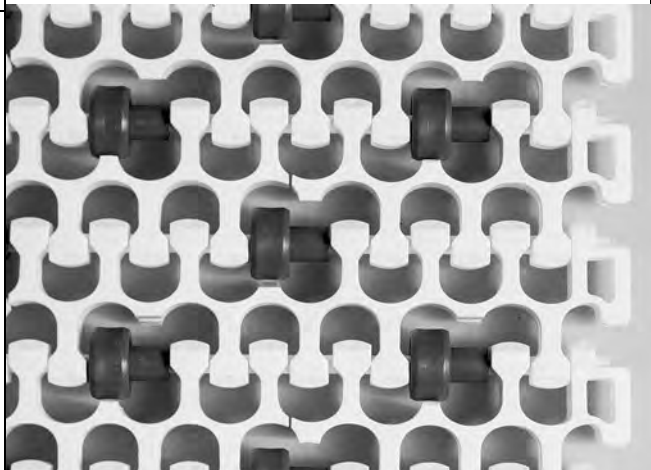

WARNING: Do not place fingers in or on this belt. Fingers can get trapped in belt openings, resulting in personal injury. This belt has pinch points due to the belt spreading and collapsing as it flexes to follow the conveyor path. Pinch points can trap fingers, hair, or clothing, causing personal injury. Do not wear loose clothing, loose gloves, or hand/finger jewelry when working near this belt. Call Customer Service for tags, flyers, and stickers containing this warning.

Additional Information

- See "Belt Selection Process" (page 5)
- See "Standard Belt Materials" (page 9)
- See "Special Application Belt Materials" (page 9)
- See "Friction Factors" (page 13)

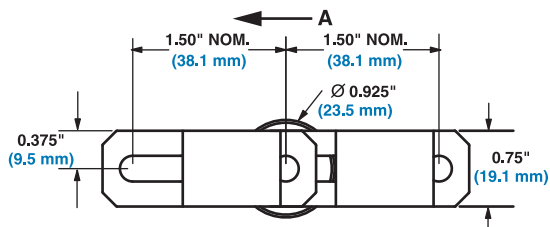

A - Preferred direction for flat turning applications

Belt Data

Belt Material	Standard Rod Material Ø 0.24 in (6.1 mm)	BS Straight Belt Strength						Roller Indents		Curved Belt Strength	Temperature Range(continuous)		W Belt Weight	
		Roller Width Spacing						in	mm		°F	°C	lb/ft ²	kg/m ²
		2 in	51 mm	3 in	7.6 mm	4 in	102 mm							
lb/ft	kg/m	lb/ft	kg/m	lb/ft	kg/m									
Polypropylene	Acetal	400	600	710	1060	900	1340	2.5	64	Contact Intralox Customer Service for curved belt strength calculations.	34 to 200	1 to 93	1.86	9.08
								3.5 to 4.5	89 to 114		-50 to 200	-46 to 93	2.82	13.8
Acetal	Nylon	630	940	1110	1650	1410	2100	2.5	64					
								3.5 to 4.5	89 to 114					
Polypropylene	Polypropylene ^a	350	520	620	920	790	1180	2.5	64					
								3.5 to 4.5	89 to 114					

a. Polypropylene rods can be installed in polypropylene belts when extra chemical resistance is required. Please note lower belt strength.

Sprocket and Support Quantity Reference				
Belt Width Range ^a		Minimum Number of Sprockets Per Shaft ^b	Wearstrips ^c	
in.	mm		Carryway	Returnway
5	127	2	2	2
6	152	2	2	2
7	178	2	2	2
8	203	2	2	2
10	254	3	3	2
12	305	3	3	2
14	356	5	3	3
15	381	5	3	3
16	406	5	3	3
18	457	5	3	3
20	508	5	4	3
24	610	7	4	3
30	762	9	5	4
32	813	9	5	4
36	914	9	5	4
42	1067	11	6	5
48	1219	13	7	5
54	1372	15	7	6
60	1524	15	8	6
72	1829	19	9	7
84	2134	21	11	8
96	2438	25	12	9
120	3048	31	15	11
144	3658	37	17	13
For Other Widths, Use Odd Number of Sprockets at Maximum 4 in. (102 mm) \varnothing Spacing			Maximum 9 in. (229 mm) \varnothing Spacing	Maximum 12 in. (305 mm) \varnothing Spacing

- a. If your belt width exceeds a number listed in the table, please refer to the sprocket and support material minimums for the next larger width range listed. Belts are available in 1.00 in. (25.4 mm) increments beginning with minimum width of 5 in. (127 mm). If the actual width is critical, consult Customer Service. Intralox does not recommend turning belts wider than 36 in. (914 mm). For turning applications that require wider belts, contact Intralox Sales Engineering.
- b. These are the minimum number of sprockets. Additional sprockets may be required for heavily loaded applications (sprockets should be placed every inch for heavily loaded applications). See Retainer Rings/Center Sprocket Offset chart on page 410 for lock down location.
- c. The number of wearstrips given does not include the hold down wearstrip.

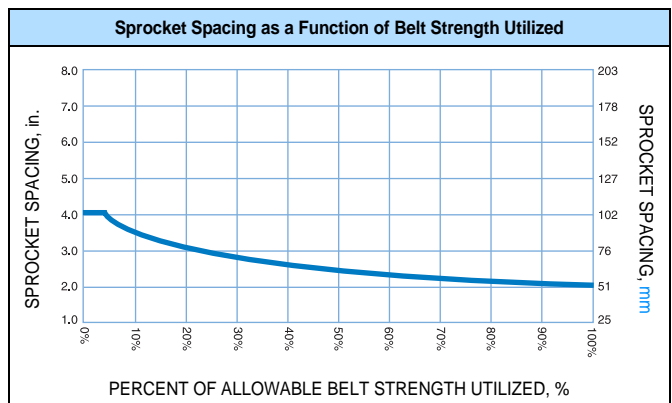
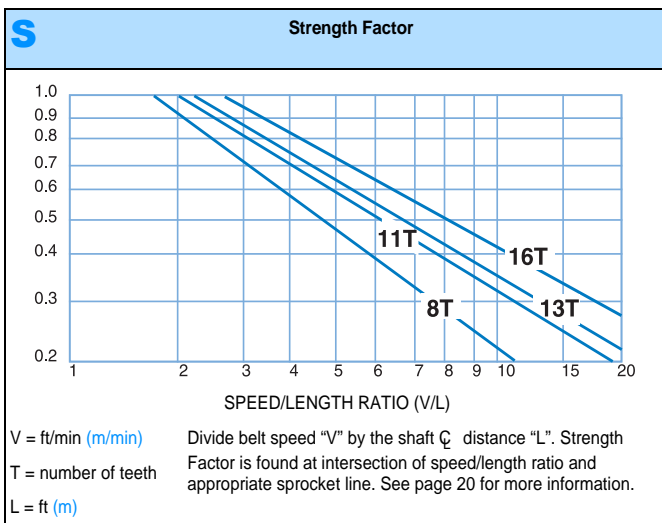

Molded Sprocket^a

No. of Teeth (Chordal Action)	Nom. Pitch Dia. in	Nom. Pitch Dia. mm	Nom. Outer Dia. in	Nom. Outer Dia. mm	Nom. Hub Width in	Nom. Hub Width mm	Available Bore Sizes			
							U.S. Sizes		Metric Sizes	
							Round in	Square in	Round mm	Square mm
8 (7.61%)	3.9	99	4.0	102	1.0	25		1.5		40
13 (2.91%)	6.3	160	6.4	163	1.0	25		2.5		60
16 (1.92%)	7.7	196	7.8	198	1.0	25		1.5		40
								2.5		60

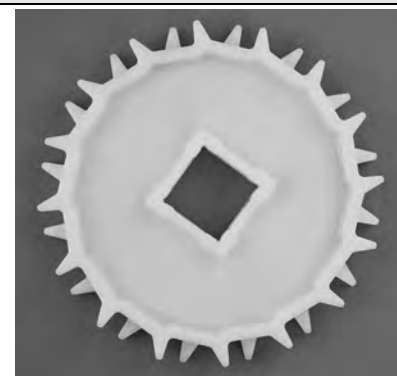

a. Contact Customer Service for lead times.

EZ Clean Sprocket^a

No. of Teeth (Chordal Action)	Nom. Pitch Dia. in	Nom. Pitch Dia. mm	Nom. Outer Dia. in	Nom. Outer Dia. mm	Nom. Hub Width in	Nom. Hub Width mm	Available Bore Sizes			
							U.S. Sizes		Metric Sizes	
							Round in	Square in	Round mm	Square mm
11 (4.05%)	5.3	135	5.4	137	1.0	25		1.5		40
13 (2.91%)	6.3	160	6.4	163	1.0	25		1.5		40



a. Contact Customer Service for lead times. When using Polyurethane sprockets, the Belt Strength for belts rated over 750 lb/ft (1120 kg/m) will be de-rated to 750 lb/ft (1120 kg/m) and all other belts will maintain their published rating. The temperature range for Polyurethane sprockets is 0° F (-18 °C) to 120° F (49 °C). Contact Customer Service for availability of Polyurethane sprockets.

Acetal Split Sprocket^a

No. of Teeth (Chordal Action)	Nom. Pitch Dia. in	Nom. Pitch Dia. mm	Nom. Outer Dia. in	Nom. Outer Dia. mm	Nom. Hub Width in	Nom. Hub Width mm	Available Bore Sizes			
							U.S. Sizes		Metric Sizes	
							Round in	Square in	Round mm	Square mm
13 (2.91%)	6.3	160	6.4	163	1.5	38	1.5, 1-7/16 ^b	1.5		



a. Contact Customer Service for lead times.
b. Tight fit round bore.

Streamline Flights		
Available Flight Height		Available Materials
in	mm	
4	102	
Polypropylene, Polyethylene		
<p>Note: Flights can be cut down to custom heights with a minimum height of 0.25 in (13 mm).</p> <p>Note: Each flight rises out of the center of its supporting module, molded as an integral part. No fasteners are required.</p> <p>Note: Flights can be provided in linear increments of 1.5 in (38 mm).</p> <p>Note: The standard indent is 5/8 in (15.9 mm).</p>		

Conveyor Frame Dimensions

Regardless of type or configuration, all conveyors using Intralox belts have some basic dimensional requirements. Specifically, dimensions “A”, “B”, “C” and “E” listed below should be implemented in any design.

For general applications and applications where end transfer of tip-sensitive product is not critical, use the “A” dimension at the bottom of the range.

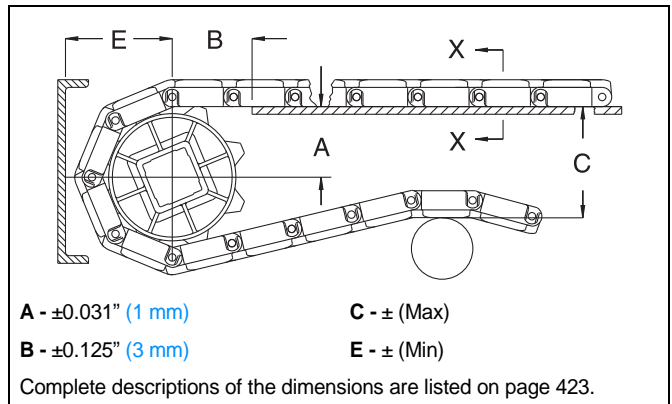

Sprocket Description		A		B		C		E		
Pitch Diameter		No. Teeth	Range (Bottom to Top)		in.	mm	in.	mm	in.	mm
in.	mm		in.	mm						
SERIES 2200 RADIUS FLUSH GRID, RADIUS WITH EDGE BEARING										
3.9	99	8	1.44	37	1.93	49	3.92	100	2.40	61
5.3	135	11	2.18	55	2.27	58	5.32	135	3.10	79
6.3	160	13	2.67	68	2.52	64	6.27	159	3.57	91
7.7	196	16	3.40	86	2.78	71	7.69	195	4.28	109
SERIES 2200 RADIUS FRICTION TOP										
3.9	99	8	1.44-1.58	36-40	1.93	49	4.17	106	2.65	67
5.3	135	11	2.18-2.29	55-58	2.27	58	5.57	142	3.35	85
6.3	160	13	2.67-2.76	68-70	2.52	64	6.52	166	3.82	97
7.7	196	16	3.40-3.47	86-88	2.78	71	7.94	202	4.53	115
SERIES 2200 RADIUS FLUSH GRID WITH INSERT ROLLERS										
3.9	99	8	1.44-1.58	36-40	1.93	49	4.00	102	2.48	63
5.3	135	11	2.18-2.29	55-58	2.27	58	5.42	138	3.19	81
6.3	160	13	2.67-2.76	68-70	2.52	64	6.36	162	3.66	93
7.7	196	16	3.40-3.47	86-88	2.78	71	7.78	198	4.37	111
SERIES 2200 RADIUS FLUSH GRID HIGH DECK, RADIUS FLUSH GRID HIGH DECK WITH EDGE BEARING										
3.9	99	8	1.44-1.58	36-40	1.93	49	4.42	112	2.90	74
5.3	135	11	2.18-2.29	55-58	2.27	58	5.82	148	3.60	91
6.3	160	13	2.67-2.76	68-70	2.52	64	6.77	172	4.07	103
7.7	196	16	3.40-3.47	86-88	2.78	71	8.19	208	4.78	121

Dead Plate Gap

Where there is a transfer point from a belt without finger transfer plates to a dead plate, there should be a gap between the surfaces to allow for the chordal action of the belt. As the belt engages its sprockets, chordal action causes the modules to move past a *fixed* point (the tip of the dead plate) with *varying* clearances. The table below shows the minimum amount of gap which occurs at the “low point” of the modules if the tip of the dead plate just comes in contact with the “high point” as the modules pass.

In some installations it may be desirable to keep the tip of the dead plate in contact with the belt, rather than allow a gap to occur. This can be done by hinging the mounting bracket for the dead plate. This allows the dead plate to move as the modules pass, but results in a small oscillating motion which may present tippage problems for sensitive containers or products.

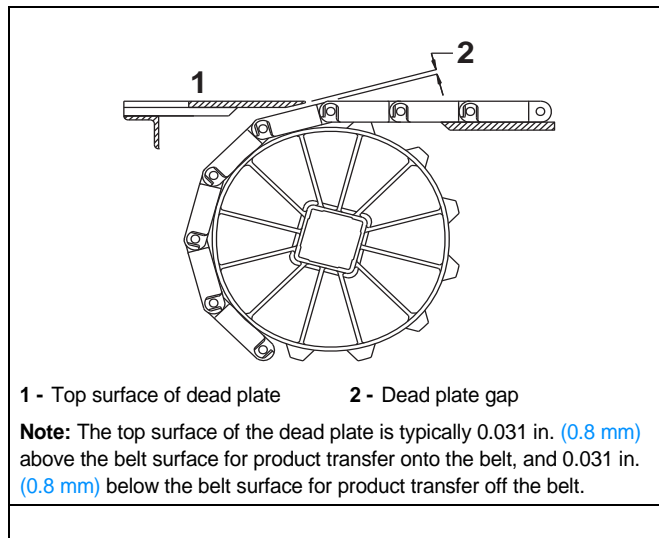

Sprocket Description		Gap		
Pitch Diameter		No. Teeth		
in.	mm		in.	mm
3.9	99	8	0.150	3.8
5.3	135	11	0.108	2.8
6.3	160	13	0.091	2.3
7.7	196	16	0.074	1.9

HOLD DOWN RAILS AND WEARSTRIPS

Intralox recommends using continuous hold down rails through an entire turn, starting at a distance of 1X the belt width before the turn and ending 1X the belt width after the turn. This applies to both carryway and returnway. The use of

hold down rails along both side of the belt over the full carryway is recommended but not mandatory.

Series 2200 is available with and without an edge tab. A wearstrip style is available for each edge style. The tab edge design allows the belt to be held down without the wearstrip interfering with the carryway surface. See “*Custom wearstrips*” (page 416).

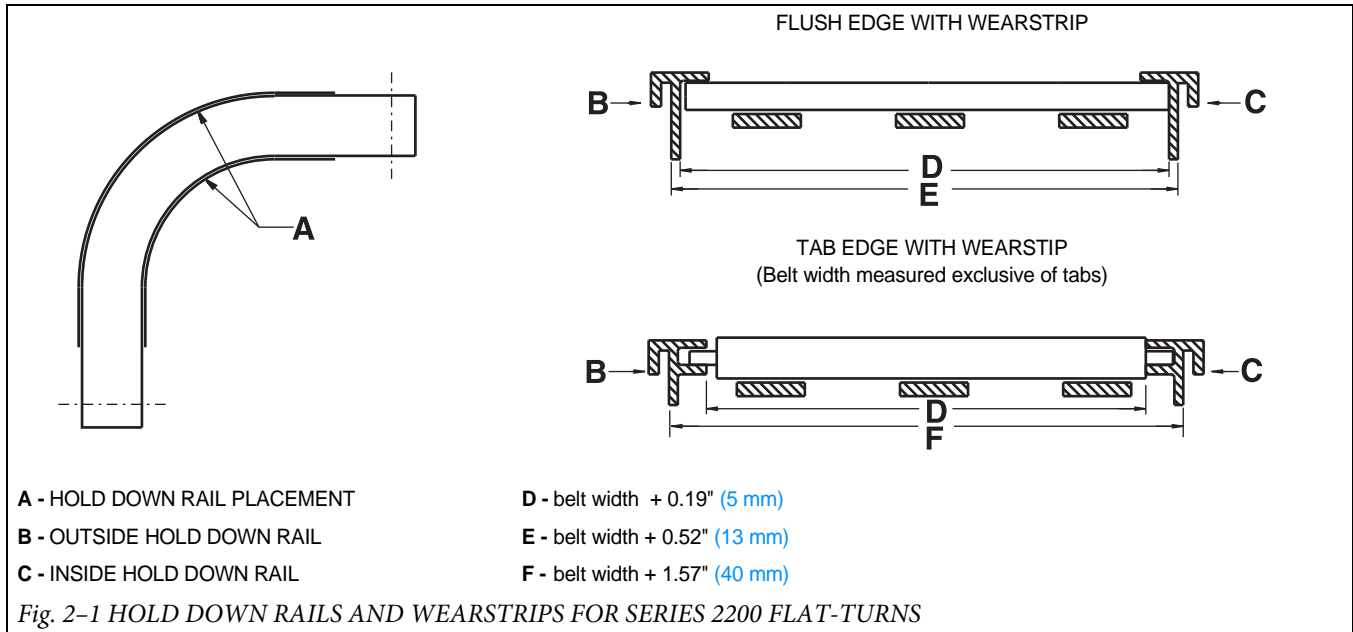

BELT SELECTION INSTRUCTIONS

ENGINEERING PROGRAM ANALYSIS FOR SERIES 2200

Intralox Customer Service Technical Support Group can calculate the estimated belt pull for radius applications using **Series 2200**. The following information is required (refer to “*Radius belt data sheet*” (page 469)):

- Any environmental conditions which may affect the friction coefficient (for dirty or abrasive conditions, use higher friction coefficients than normal)
- Belt width
- Length of each straight run
- Turning angle of each turn

- Turn direction of each turn
- Inside turning radius of each turn
- Carryway/hold down rail material
- Product loading lb/ft² (kg/m²)
- Product back-up conditions
- Belt speed
- Elevation changes on each section
- Operating temperatures.

For assistance with radius belt and low-tension capstan drive spiral selections, contact Intralox Customer Service Technical Support Group. The Engineering Program should be run to ensure that the belt is strong enough for the radius application in question.

SERIES 2200 DESIGN GUIDE SUMMARY

For more information, see the *Installation, Maintenance and Troubleshooting manual* available from Intralox.

- A** - The minimum and recommended turning radius for **Series 2200** is 2.2 times the belt width, measured from the inside edge.
- B** - The minimum straight run required between turns of opposing direction is 2.0 times the belt width. Shorter straight sections will lead to high wear on the edge guide rail and high pull stresses in the belt.
- C** - There is no minimum straight run required between turns that are in the same direction.
- D** - The minimum final straight run (leading to drive shaft) should be a minimum of 5 ft. (1.5 m). If 5 ft. (1.5 m) is not feasible, a shorter distance (down to 1.5 x belt width) would require a weighted take up in order to avoid sprocket wear and tracking problems. See "Special Take-Up Arrangements" (page 431).
- E** - The minimum length of the first straight run (immediately after the idle shaft) is 1.5 times the belt width. When shorter lengths are required (down to 1.0 times the width), an idle roller may be used in place of sprockets.
- F** - IDLE SHAFT
- G** - 1ST TURN
- H** - BELT WIDTH
- I** - BELT TRAVEL
- J** - 2ND TURN
- K** - DRIVE MOTOR
- L** - DRIVE SHAFT

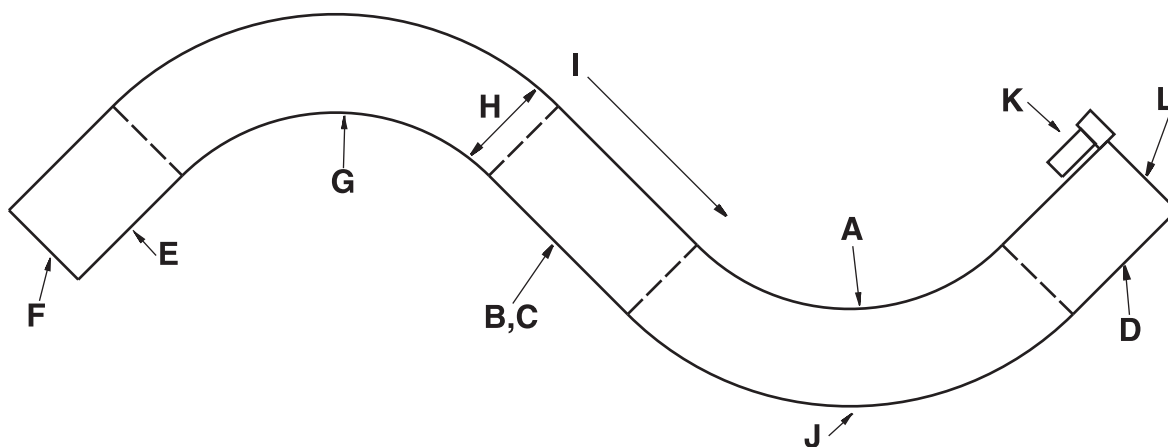
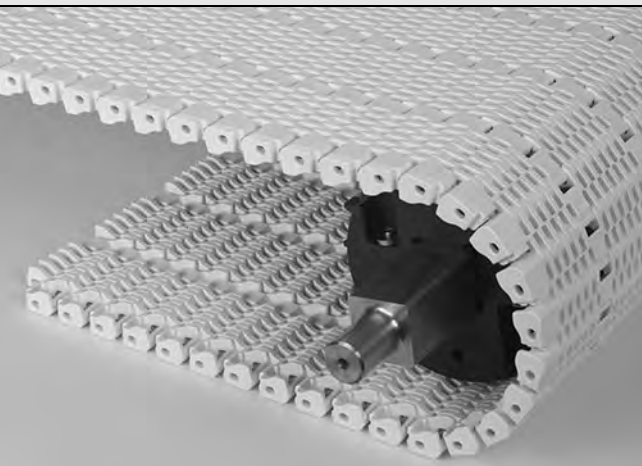
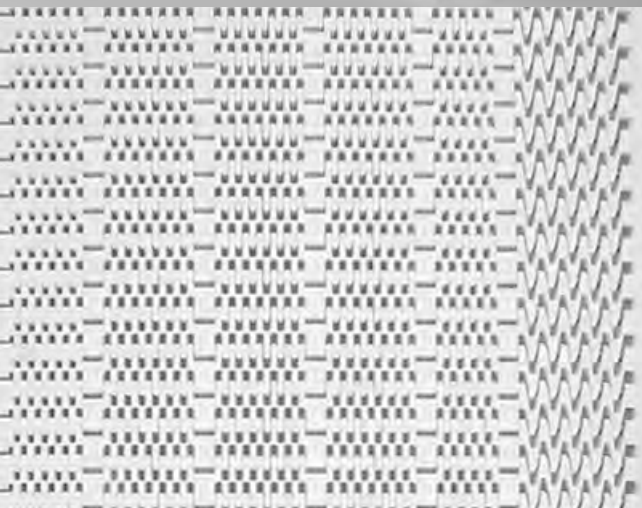
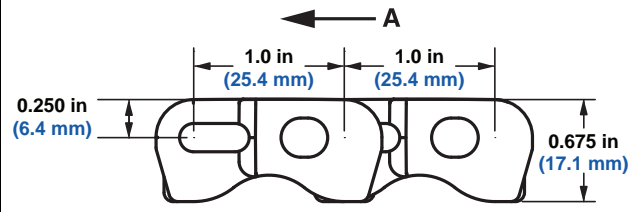

Fig. 2-2 TYPICAL 2-TURN RADIUS LAYOUT

Flush Grid Nose-Roller Tight Turning			
	in	mm	
Pitch	1.0	25.4	
Minimum Width	12.0	305	
Maximum Width	30.0	762	
Width Increments	3.0	76.2	
Max Opening Size (Sphere)	0.245	6.2	
Open Area (Fully Extended)	28%		
Hinge Style	Closed		
Drive Method	Center/Hinge		
Product Notes			
<ul style="list-style-type: none"> • Contact Intralox for precise belt measurements and stock status before designing equipment or ordering a belt. • Designed for sideflexing applications with a minimum turn radius of 1.7 times belt width (measured from inside edge). • Turn radius for belts 12.0 in-27.0 in (305 mm-685.8 mm) is 1.7 times belt width. • Turn radius for belts 30.0 in (762 mm) is 1.75 times belt width. • Minimizes floor space requirements. • Available with tight turning modules built on one side. Belting can turn either clockwise or counterclockwise. Turning direction must be specified at order. • Not available for "S" turn applications. • Can execute 180-degree turns. • Smooth upper surface provides free product movement. • Underside design allows the belt to run smoothly around a 0.75 in (19.1 mm) nosebar. • Sprockets have large lug teeth that enhance sprocket life. • Minimum back tension required. • Smaller opening size enhances belt safety. • Uses headless rods. • Sprocket placement is every 3.00 in (76.2 mm) from outer edge, except drive pocket nearest inner edge. Drive pocket nearest inner edge is 3.75 in (95.3 mm) from inner edge. 			
Additional Information			
<ul style="list-style-type: none"> • See "Belt Selection Process" (page 5). • See "Standard Belt Materials" (page 9). • See "Special Application Belt Materials" (page 9). 			



A -Preferred direction for flat turning applications

Belt Data								
Belt Material	Standard Rod Material Ø 0.180 in (4.6 mm)	BS	Straight Belt Strength	Curved Belt Strength	Temperature Range (continuous)		W	Belt Weight
					°F	°C		
Acetal	Nylon	900	1339	Contact Intralox Customer Service for curved belt strength calculations.	-50 to 200	-46 to 93	2.40	11.72

Flush Grid Nose-Roller Tight Turning with Edge Bearing

	in	mm
Pitch	1.00	25.4
Minimum Width	12.0	305
Maximum Width	30.0	762
Width Increments	3.0	76.2
Max Opening Size (Sphere)	0.245	6.2
Open Area	28%	
Hinge Style	Closed	
Drive Method	Center/Hinge	

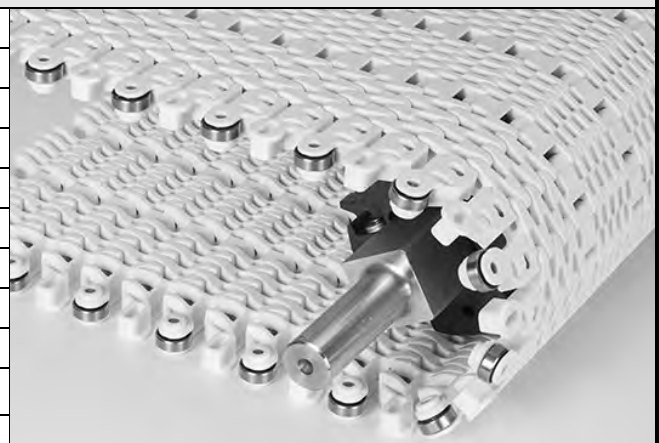

Product Notes

- **Contact Intralox for precise belt measurements and stock status before designing equipment or ordering a belt.**
- Designed for sideflexing applications with a minimum turn radius of 1.7 times belt width (measured from inside edge).
- Turn radius for belts 12.0 in-27.0 in (305 mm-685.8 mm) is 1.7 times belt width.
- Turn radius for belts 30.0 in (762 mm) is 1.75 times belt width.
- Not available for "S" turn applications.
- Edge bearings are available on one side of the belt. Belts can turn clockwise or counterclockwise. Turn direction must be specified when ordering.
- Bearings must be placed on the inside edge of the turn.
- Bearings must be configured in every other row of the belt.
- Bearings are stainless steel.
- Stainless steel pins retain bearings in the belt.
- Underside design allows the belt to run smoothly around a 0.75-in (19.1-mm) nosebar.
- See *Series 2300 Flush Grid Nose-Roller Tight Turning Design Guidelines* for details about nosebar placement.
- Use the Intralox Engineering Program to determine if the edge bearing is suitable for your application.
- Uses headless rods.
- Smaller opening size enhances belt safety.

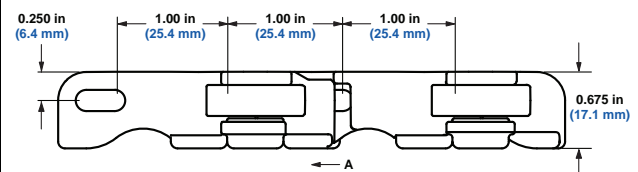
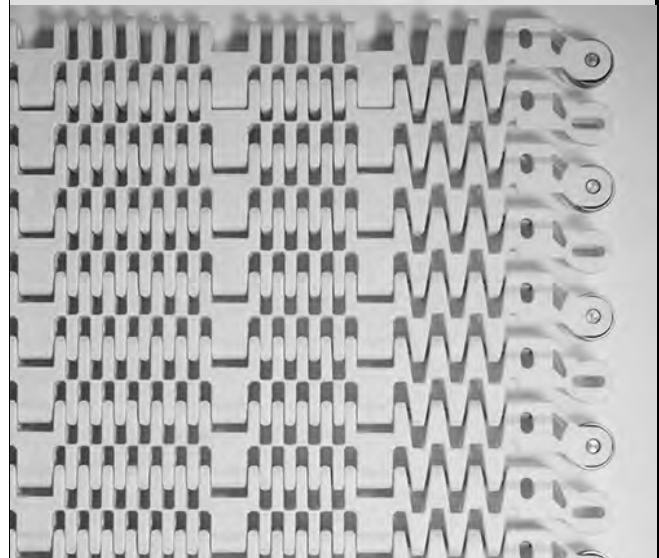

A - Preferred direction for flat turning applications

Additional Information

- See "Belt Selection Process" (page 5).
- See "Standard Belt Materials" (page 9).
- See "Special Application Belt Materials" (page 9).

Belt Data

Base Belt Material	Standard Rod Material Ø 0.18 in (4.6 mm)	BS Straight Belt Strength	Curved Belt Strength		Temperature Range (continuous)		W Belt Weight		
			lb/ft	kg/m	°F	°C	lb/ft ²	kg/m ²	
Acetal	Nylon	900	1339	Contact Intralox Customer Service for curved belt strength calculations.		0 to 200	-17.8 to 93	2.40	11.72

Sprocket and Support Quantity Reference				
Belt Width Range		Minimum Number of Sprockets Per Shaft ^a	Wearstrips ^b	
in	mm		Carryway ^c	Returnway
12	305	2	3	2
15	381	3	3	3
18	457	3	3	3
21	533	4	4	3
24	610	4	4	3
27	686	5	5	4
30	762	5	5	4

- a. These are the minimum number of sprockets. Additional sprockets may be required for heavily loaded applications.
- b. The number of wearstrips listed does not include hold down wearstrips.
- c. Place wearstrips between drive sprockets. Refer to Carryway Wearstrip Location from Edge of Belt table for dimension values.

Carryway Wearstrip Location from Edge of Belt				
Wearstrip ^a	Distance from Edge		Belt Width	
	in	mm	in	mm
1	1.5	38	12-30	305-762
2	4.5	114	12-30	305-762
3	7.5	191	12-30	305-762
4	10.5	267	12-30	305-762
5	13.5	343	15-30	381-762
6	16.5	419	18-30	457-762
7	19.5	495	21-30	533-762
8	22.5	572	24-30	610-762
9	25.5	648	27-30	686-762
10	28.5	724	30	762

- a. 1.0 in (25.4 mm) minimum wearstrip width

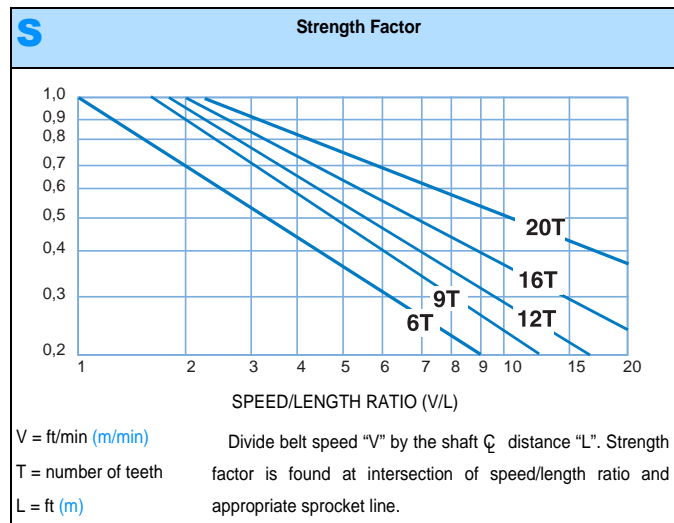
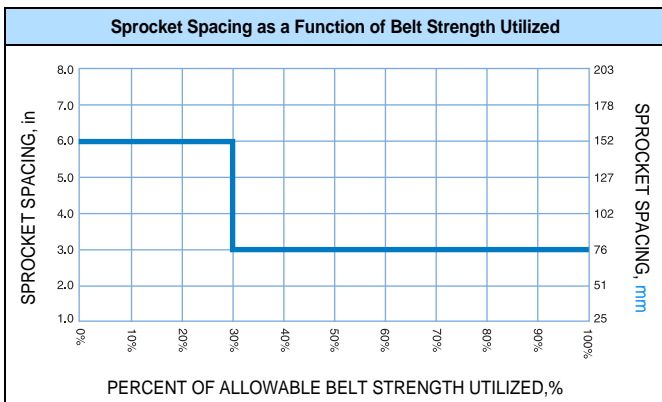

Nylon Split Sprocket ^a										
No. of Teeth (Chordal Action)	Nom. Pitch Dia. in	Nom. Pitch Dia. mm	Nom. Outer Dia. in	Nom. Outer Dia. mm	Nom. Hub Width in	Nom. Hub Width mm	Available Bore Sizes			
							U.S. Sizes		Metric Sizes	
							Round in	Square in	Round mm	Square mm
16 (1.92%)	5.1	130	5.2	132	1.9	38	1.25	1.5	40	40
18 (1.52%)	5.8	147	5.9	150	1.9	38	1.25 1-7/16	1.5	40	40
20 (1.52%)	6.4	163	6.5	165	1.9	38	1.25 1-7/16	1.5	40	40

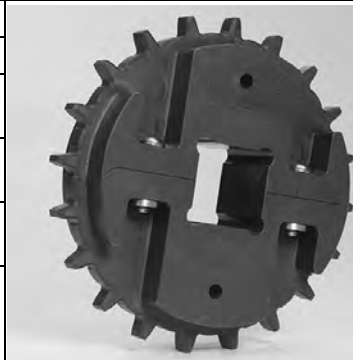

a. Contact Customer Service for lead times.

Nylon Sprocket ^a										
No. of Teeth (Chordal Action)	Nom. Pitch Dia. in	Nom. Pitch Dia. mm	Nom. Outer Dia. in	Nom. Outer Dia. mm	Nom. Hub Width in	Nom. Hub Width mm	Available Bore Sizes			
							U.S. Sizes		Metric Sizes	
							Round in	Square in	Round mm	Square mm
12 (3.41%)	3.9	99	3.9	99	1.0	25	1.25	1.5	25 30 40	40
16 (1.92%)	5.1	130	5.2	132	1.0	25	1.25	1.5	40	40
18 (1.52%)	5.8	147	5.9	150	1.0	25	1.25	1.5	40	40
20 (1.52%)	6.4	163	6.5	165	1.0	25	1.25	1.5	40	40

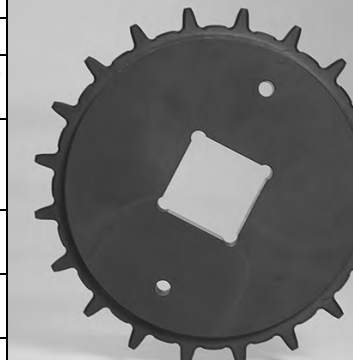

a. Contact Customer Service for lead times.

Conveyor Frame Dimensions

Regardless of type or configuration, all conveyors using Intralox belts have some basic dimensional requirements. Specifically, dimensions “A”, “B”, “C”, and “E” listed below should be implemented in any design.

For general applications and applications where end transfer of tip-sensitive product is not critical, use the “A” dimension at the bottom of the range.

Conveyor frame dimensions are established using the top of the roller as the top of the belt and the bottom of the module as the bottom of the belt. “B” dimension is based on a 0.5 in (12.7 mm) thick carryway.

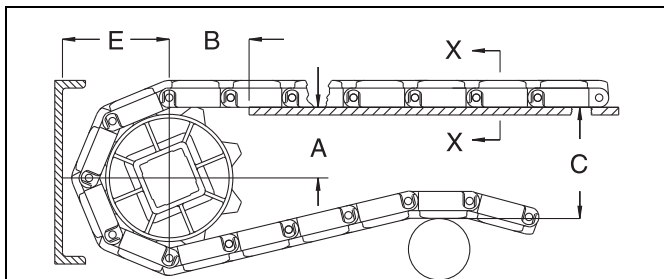

- A - ±0.031 in (1 mm)
- B - ±0.125 in (3 mm)
- C - ± (Max)
- E - ± (Min)

Complete descriptions of the dimensions are listed on page 385 of the 2015 Engineering Manual.

Sprocket Description		A		B		C		E		
Pitch Diameter		No. Teeth	Range (Bottom to Top)		in	mm	in	mm	in	mm
in	mm		in	mm						
3.9	99	12	1.44-1.51	37-38	1.92	49	3.69	94	2.24	57
5.1	130	16	2.09-2.14	53-54	2.27	58	4.95	126	2.88	73
5.8	147	18	2.41-2.45	61-62	2.46	62	5.58	142	3.19	81
6.4	163	20	2.73-2.77	69-70	2.57	65	6.22	158	3.51	89

Dead Plate Gap

Where there is a transfer point from a belt without finger transfer plates to a dead plate, there should be a gap between the surfaces to allow for the chordal action of the belt. As the belt engages its sprockets, chordal action causes the modules to move past a *fixed* point (the tip of the dead plate) with *varying* clearances. The table below shows the minimum amount of gap which occurs at the “low point” of the modules if the tip of the dead plate just comes in contact with the “high point” as the modules pass.

In some installations, it may be desirable to keep the tip of the dead plate in contact with the belt rather than allow a gap to occur. This can be done by hinging the mounting bracket for the dead plate. This allows the dead plate to move as the modules pass, but results in a small oscillating motion which may present tippage problems for sensitive containers or products.

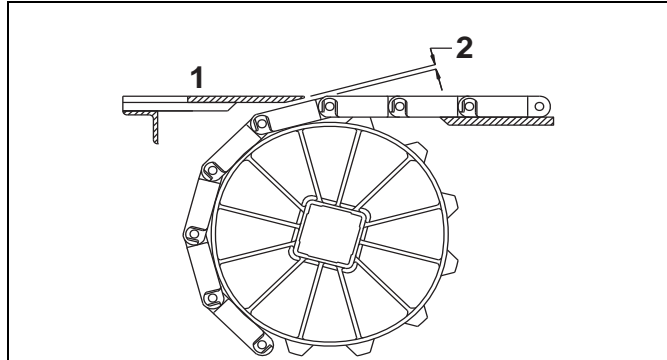

1 - Top surface of dead plate 2 - Dead plate gap

Note: The top surface of the dead plate is typically 0.031 in (0.8 mm) above the belt surface for product transfer onto the belt, and 0.031 in (0.8 mm) below the belt surface for product transfer off the belt.

Sprocket Description		Gap		
Pitch Diameter		No. Teeth	in	mm
in	mm			
3.9	99	12	0.065	1.7
5.1	130	16	0.050	1.3
6.4	163	20	0.039	1.0

Radius Flush Grid (1.7)		
	in	mm
Pitch	1.00	25.4
Minimum Width	7	178
Width Increments	0.50	12.7
Opening Size (approximate)	0.35 x 0.30	8.9 x 7.6
Open Area	42%	
Product Contact Area	23%	
Hinge Style	Open	
Drive Method	Hinge-driven	

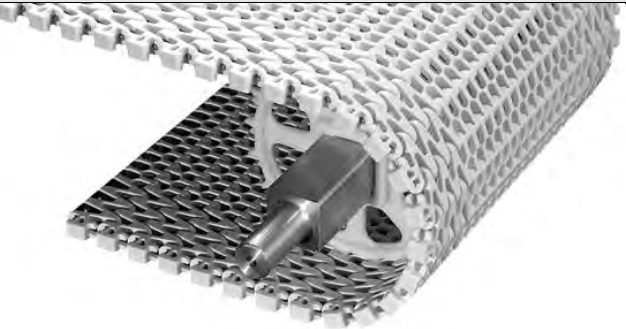

Product Notes

- Contact Intralox for precise belt measurements and stock status before designing equipment or ordering a belt.
- Designed for radius applications with a minimum turn radius of 1.7 times the belt width (measured from inside edge). Maximizes plant floor space.
- Uses headless rods.
- The Intralox Engineering Program will help predict the strength requirements of most radius applications, ensuring that the belt is strong enough for the application.
- Belt openings pass straight through belt, making it easy to clean.
- Sprocket drive system is designed to minimize wear and requires very low return side tension.
- Available with tight turning modules built into one side or both sides of the belt. Radius belt wearstrips are available.
- Looking in the direction of flat turning travel, the minimum sprocket indent from the right side belt edge with tight turning modules is 2.625 in (66.7 mm). Minimum sprocket indent from the left side belt edge with tight turning modules is 2.875 in (73 mm).
- Belts can be ordered with 1.7 modules on the inside and 2.2 modules on the outside for improved strength.
- Contact sales engineering before using a belt width greater than 18 in (457 mm) in spiral and flat turning applications.
- The minimum nosebar diameter is 1.375 in (34.9 mm).

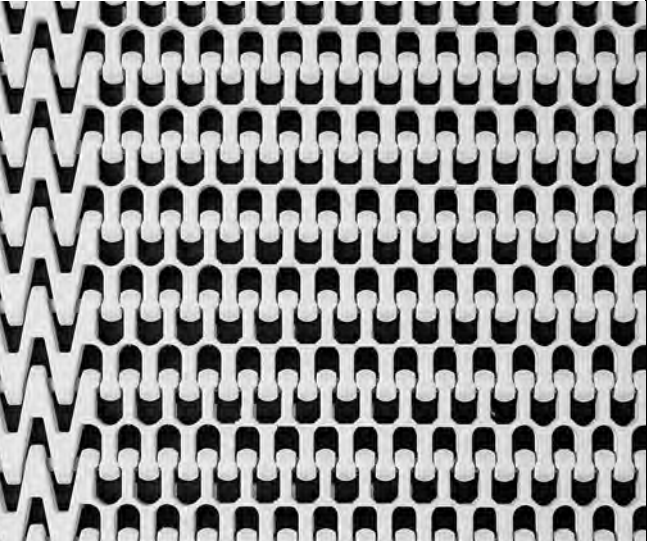

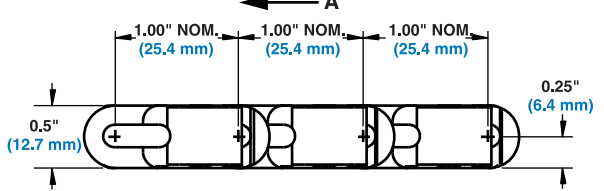

A - Preferred direction for flat turning applications

Additional Information			
<ul style="list-style-type: none"> See "Belt Selection Process" (page 5) See "Standard Belt Materials" (page 9) See "Friction Factors" (page 13) 			

Belt Data								
Belt Material	Standard Rod Material Ø 0.18 in (4.57 mm)	BS Straight Belt Strength		Curved Belt Strength	Temperature Range (continuous)		W Belt Weight	
		Polypropylene	Acetal		600	892.8	Contact Intralox Customer Service for curved belt strength calculations.	34 to 200
Acetal	Nylon	600	892.8	-50 to 200	-46 to 93	1.73		8.44
Polypropylene	Polypropylene ^a	600	892.8	34 to 220	1 to 104	1.12		5.47

a. Polypropylene rods can be installed in polypropylene belts when extra chemical resistance is required. Please note lower belt strength.

Radius Flush Grid (2.2)

	in	mm
Pitch	1.00	25.4
Minimum Width	4	102
Width Increments	0.50	12.7
Opening Size (approximate)	0.35 × 0.30	8.9 × 7.6
Open Area	42%	
Product Contact Area	23%	
Hinge Style	Open	
Drive Method	Hinge-driven	

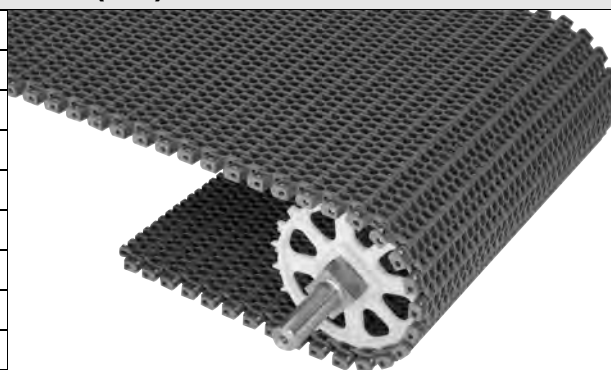

Product Notes

- **Contact Intralox for precise belt measurements and stock status before designing equipment or ordering a belt.**
- Designed for radius applications with a minimum turn radius of 2.2 times the belt width (measured from inside edge).
- Uses headless rods.
- Available with hold down guide, see page 332 for details.
- The minimum nosebar diameter is 1.5 in (38.1 mm) with hold down guides and 1.375 in (34.9 mm) without hold down guides.
- The Intralox Engineering Program will help predict the strength requirements for radius applications, ensuring that the belt is strong enough for the application.
- Belt openings pass straight through belt, making it easy to clean.
- Sprocket drive system is designed to minimize wear and requires very low return side tension.
- Radius belt wearstrips are available.
- Contact Sales Engineering before using a belt width greater than 36 in (914 mm) in a flat turning or spiral applications.

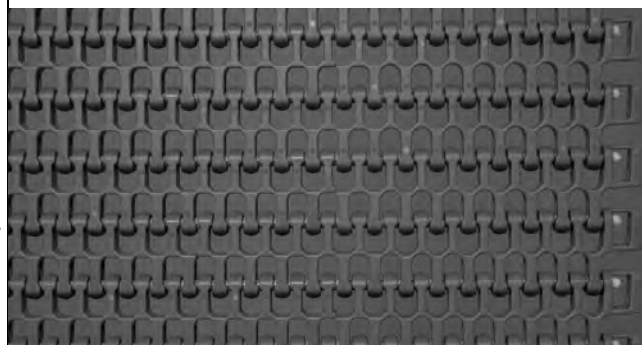

Additional Information

- See "Belt Selection Process" (page 5)
- See "Standard Belt Materials" (page 9)
- See "Special Application Belt Materials" (page 9)
- See "Friction Factors" (page 13)

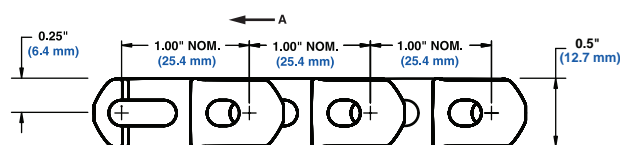

A -Preferred direction for flat turning applications

Belt Data

Belt Material	Standard Rod Material Ø 0.18 in (4.57 mm)	BS		Curved Belt Strength	Temperature Range (continuous)		W	
		Straight Belt Strength			°F	°C	Belt Weight	
		lb/ft	kg/m			lb/ft ²	kg/m ²	
Polypropylene	Acetal	1200	1785	Contact Intralox Customer Service for curved belt strength calculations.	34 to 200	1 to 93	1.10	5.40
Acetal	Nylon	1700	2528		-50 to 200	-46 to 93	1.59	7.76
Detectable Acetal	HR Nylon	1300	1935		-50 to 200	-46 to 93	1.70	8.30
Polypropylene	Polypropylene ^a	1000	1487		34 to 220	1 to 104	1.04	5.11
X-Ray Detectable Acetal ^b	X-Ray Detectable Acetal	1700	2528		-50 to 200	-46 to 93	1.85	9.03

a. Polypropylene rods can be installed in polypropylene belts when extra chemical resistance is required. Please note lower belt strength.

b. Designed specifically to be detected by x-ray machines.

Mold to Width Radius Flush Grid 2.2

	in	mm
Pitch	1.00	25.4
Molded Width	4	101.6
Opening Size (approximate)	0.35 x 0.30	8.9 x 7.6
Open Area	42%	
Hinge Style	Open	
Drive Method	Hinge-driven	

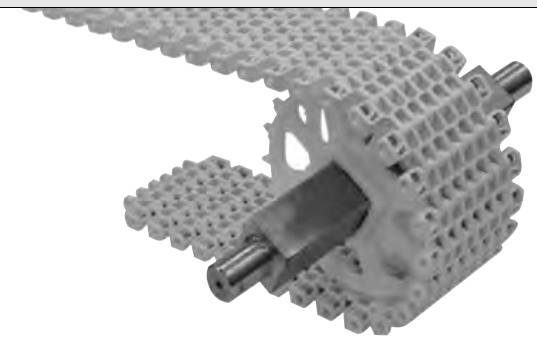

Product Notes

- **Contact Intralox for precise belt measurements and stock status before designing equipment or ordering a belt.**
- Available with hold down guides, see page 332.
- The minimum nosebar diameter is 1.5 in (38.1 mm) with hold down guides and 1.375 in (34.9 mm) without hold down guides.
- The Intralox Engineering Program will help predict the strength requirements of most radius applications, ensuring that the belt is strong enough for the application.
- Belt openings pass straight through belt, making it easy to clean.
- Sprocket drive system is designed to minimize wear and requires very low return side tension.
- Radius belt wearstrips are available.
- Hold down guides cannot be used with 2 in and 2.9 in pitch diameter sprockets or 3.9 in pitch diameter square bore sprockets.
- Uses headed rods.

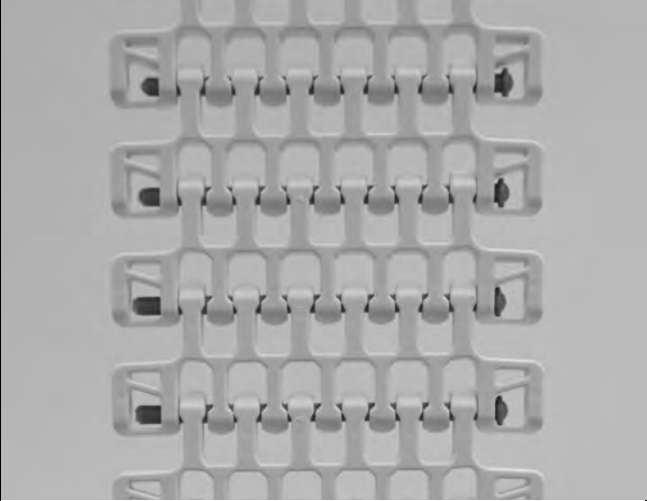

Additional Information

- See "Belt Selection Process" (page 5)
- See "Standard Belt Materials" (page 9)
- See "Special Application Belt Materials" (page 9)
- See "Friction Factors" (page 13)

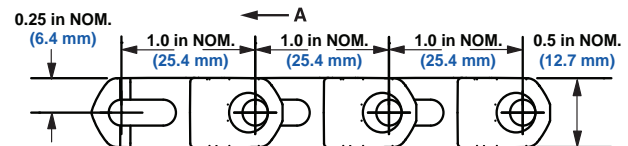

A -Preferred direction for flat turning applications

Belt Data

Belt Material	Standard Rod Material Ø 0.18 in (4.57 mm)	BS	Straight Belt Strength	Curved Belt Strength	Temperature Range (continuous)		W Belt Weight	
					°F	°C	lb/ft	kg/m
Acetal	Nylon	560	254	Contact Intralox Customer Service for curved belt strength calculations.	-50 to 200	-46 to 93	0.56	0.83
Polypropylene	Acetal	400	181		34 to 200	1 to 93	0.39	0.57

Radius Flush Grid High Deck

	in	mm
Pitch	1.00	25.4
Minimum Width	4	102
Width Increments	0.50	12.7
Opening Size (approximate)	0.35 × 0.30	8.9 × 7.6
Open Area	42%	
Product Contact Area	23%	
Hinge Style	Open	
Drive Method	Hinge-driven	

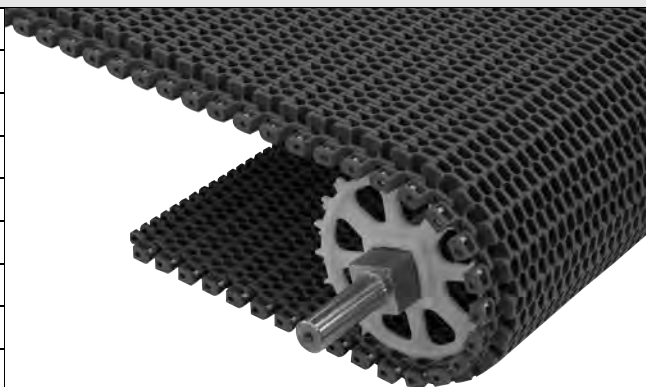

Product Notes

- **Contact Intralox for precise belt measurements and stock status before designing equipment or ordering a belt.**
- Flush Grid High Deck is 0.4 in (10 mm) higher than the standard Series 2400 belt.
- Uses headless rods.
- Makes turns with an inside radius of 2.2 times the belt width.
- Flush Grid High Deck has more beam strength than the standard Series 2400 belt, which can reduce retrofit costs in spirals.
- Works with standard Series 2400 wearstrips.
- Standard indent for Flush Grid High Deck is 0.875 in (22.2 mm).

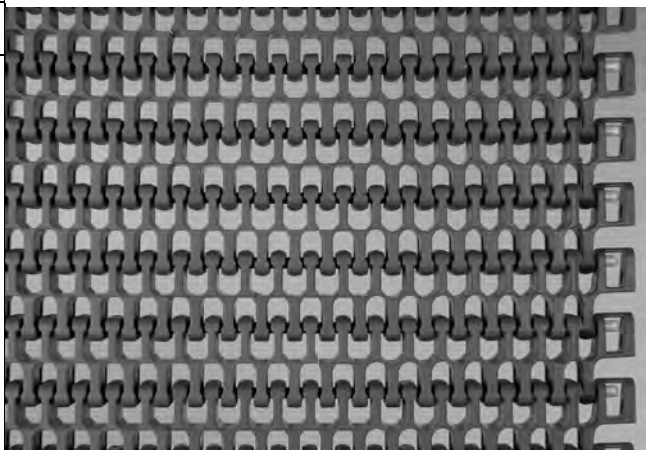

Additional Information

- See “Belt Selection Process” (page 5)
- See “Standard Belt Materials” (page 9)
- See “Special Application Belt Materials” (page 9)
- See “Friction Factors” (page 13)

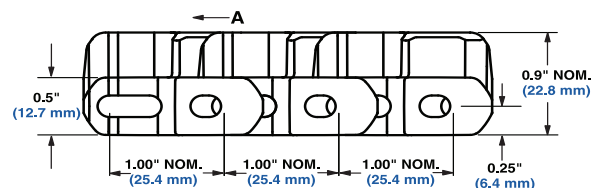

A -Preferred direction for flat turning applications

Belt Data

Belt Material	Standard Rod Material Ø 0.18 in (4.57 mm)	BS Straight Belt Strength		Curved Belt Strength	Temperature Range (continuous)		W Belt Weight	
		lb/ft	kg/m		°F	°C	lb/ft ²	kg/m ²
Polypropylene	Acetal	1200	1785	Contact Intralox Customer Service for curved belt strength calculations.	34 to 200	1 to 93	1.90	9.28
HR Nylon	Nylon	1700	2530		-50 to 240	-46 to 116	2.30	11.23
Acetal	Acetal	1700	2530		-50 to 200	-46 to 93	2.83	13.82

Radius Friction Top (2.2)

	in	mm
Pitch	1.00	25.4
Minimum Width	4	102
Width Increments	0.50	12.7
Opening Size (approximate)	0.35 x 0.30	8.9 x 7.6
Open Area	42%	
Product Contact Area	23%	
Hinge Style	Open	
Drive Method	Hinge-driven	

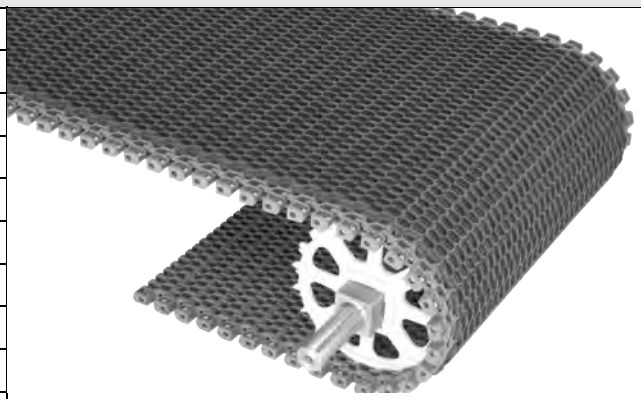

Product Notes

- **Contact Intralox for precise belt measurements and stock status before designing equipment or ordering a belt.**
- Available with hold down guide, see page 332 for details.
- Friction top available in grey PP with grey rubber and white PP with white rubber.
- The minimum nosebar diameter is 1.5 in (38.1 mm) with hold down guides and 1.375 in (34.9 mm) without hold down guides.
- Uses headless rods.
- Radius belt wearstrips are available.
- Contact Sales Engineering before using a belt width greater than 36 in (914 mm) in a flat turning or spiral applications.
- Indent for friction surface is molded at 1.125" (28.6mm).
- Temperature, environmental conditions, and product characteristics affect the effective maximum degree of incline. Take these items into consideration when designing conveyor systems utilizing these belts.

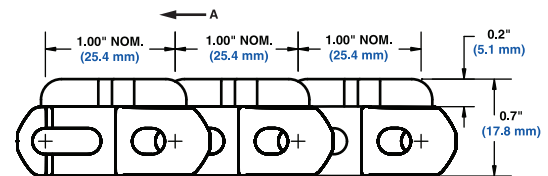
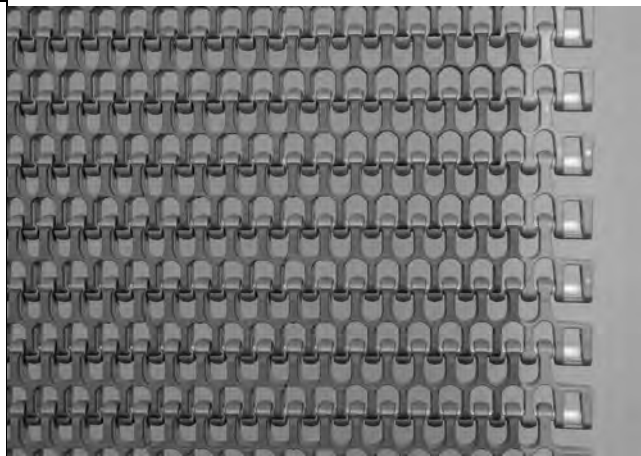

A -Preferred direction for flat turning applications

Additional Information

- See "Belt Selection Process" (page 5)
- See "Standard Belt Materials" (page 9)
- See "Special Application Belt Materials" (page 9)
- See "Friction Factors" (page 13)

Belt Data

Base Belt Material	Base/Friction Color	Standard Rod Material Ø 0.18 in (4.57 mm)	BS Belt Strength		Curved Belt Strength	Temperature Range (continuous)		W Belt Weight		Friction Top Hardness	Agency Acceptability	
			lb/ft	kg/m		°F	°C	lb/ft ²	kg/m ²		FDA (USA)	EU MC ^b
Polypropylene	Grey/Grey	Acetal	1200	1785	Contact Intralox Customer Service for curved belt strength calculations.	34 to 150	1 to 66	1.35	6.59	64 Shore A		
Polypropylene	White/White	Acetal	1200	1785		34 to 150	1 to 66	1.35	6.59	55 Shore A	a	c
Polypropylene	Grey/Grey	Polypropylene	1000	1487		34 to 150	1 to 66	1.29	6.30	64 Shore A		
Polypropylene	White/White	Polypropylene	1000	1487		34 to 150	1 to 66	1.29	6.30	55 Shore A	a	c
Polypropylene	High Performance FT Blue/Blue	Acetal	1200	1785		34 to 212	1 to 100	1.35	6.59	59 Shore A	a	c

• - Fully compliant

a - FDA Compliant with Restriction: Do not use in direct contact with fatty foods.

b - European Migration Certificate providing approval for food contact according to EU Regulation 10/2011.

c - EU compliant with Restriction: Do not use in direct contact with fatty foods.

Radius Flush Grid (2.4) with Insert Rollers		
	in	mm
Pitch	1.00	25.4
Minimum Width	9	229
Width Increments	1.00	25.4
Opening Size (approximate)	0.35 x 0.30	8.9 x 7.6
Open Area	42%	
Product Contact Area	23%	
Hinge Style	Open	
Drive Method	Hinge-driven	

Product Notes

- Contact Intralox for precise belt measurements and stock status before designing equipment or ordering a belt.
- For radius applications requiring low back pressure accumulation with minimum radius of 2.4 times belt width (measured from inside edge).
- Acetal rollers
- Uses headless rods.
- Standard roller width spacings: 2 in (51 mm), 3 in (76 mm) or 4 in (102 mm).
- Standard roller row spacings: 2 in (51 mm) or 4 in (102 mm).
- Roller Indents: 3.5 in (89 mm) or 4 in (102 mm) based on roller width spacing selected.
- Sprockets must NOT be placed in line with rollers.
- For low back pressure applications, place wearstrip between rollers. For driven applications, place wearstrip directly under rollers.
- Contact Sales Engineering before using a belt width greater than 24 in (610 mm) in a flat turning or spiral applications.
- Belts 12 in (305 mm) wide and less have a turn ratio of 1.7.

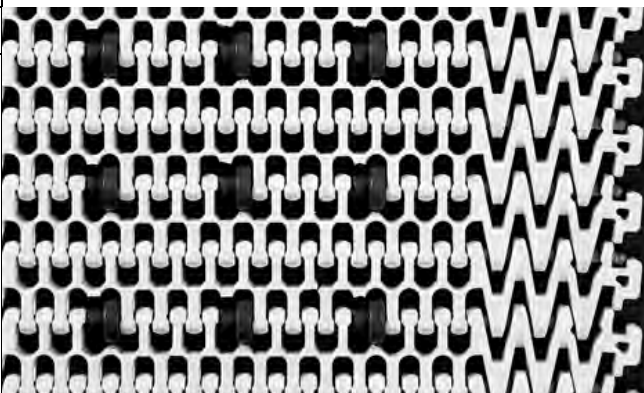
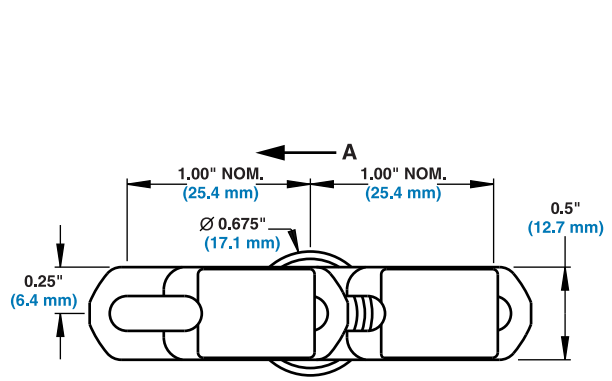



A - Preferred direction for flat turning applications

Additional Information		
<ul style="list-style-type: none"> See "Belt Selection Process" (page 5) See "Standard Belt Materials" (page 9) See "Special Application Belt Materials" (page 9) See "Friction Factors" (page 13) 		

Belt Data										
Belt Material	Standard Rod Material Ø 0.18 in (4.57 mm)	BS Straight Belt Strength	Roller Indents		Curved Belt Strength	Temperature Range (continuous)		W Belt Weight		
			lb/ft	kg/m		in	mm	°F	°C	lb/ft²
Polypropylene	Acetal	500	744	3.5 or 4.0	89 or 102	Contact Intralox Customer Service for curved belt strength calculations.	34 to 200	1 to 93	1.20	5.86
Acetal	Nylon	500	744	3.5 or 4.0	89 or 102		-50 to 200	-46 to 93	1.73	8.44
Polypropylene	Polypropylene	500	744	3.5 or 4.0	89 or 102		34 to 220	1 to 104	1.12	5.47

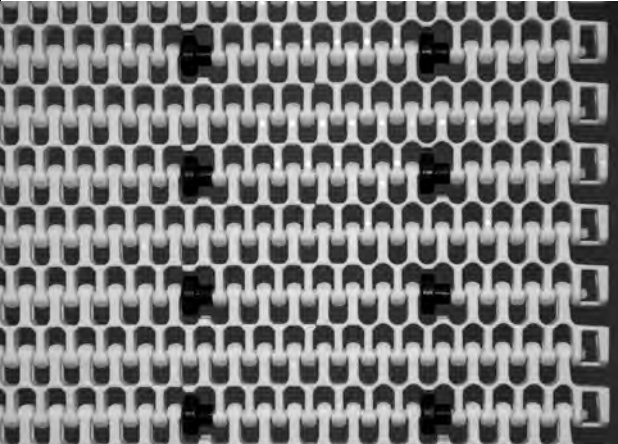
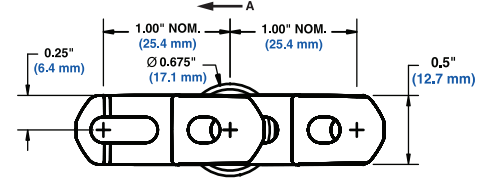
Radius Flush Grid (2.8) with Insert Rollers		
	in	mm
Pitch	1.00	25.4
Minimum Width	6	152
Width Increments	1.00	25.4
Opening Size (approximate)	0.35 x 0.30	8.9 x 7.6
Open Area	42%	
Product Contact Area	23%	
Hinge Style	Open	
Drive Method	Hinge-driven	
Product Notes		
<ul style="list-style-type: none"> • Contact Intralox for precise belt measurements and stock status before designing equipment or ordering a belt. • This belt uses the Series 2400 2.2 turn radius flush grid as its base. • Uses headless rods. • Due to roller placement, the turn radius increases to 2.8. • For radius applications requiring low back pressure accumulation with minimum radius of 2.8 times belt width (measured from inside edge). • Standard roller width spacings: 2 in (51 mm), 3 in (76 mm) or 4 in (102 mm). • Standard roller row spacings: 2 in (51 mm) or 4 in (102 mm). • Roller indents: 2 in (51 mm), 2.5 in (63 mm), 3 in (76 mm) or 3.5 in (89 mm) based on roller width spacing selected. • Minimum width with hold down guides is 8 in (203 mm). • Minimum roller indent with hold down guides is 3 in (76 mm). • Sprockets must NOT be placed in line with rollers. • For low back pressure applications, place wearstrip between rollers. For driven applications, place wearstrip directly under rollers. • Contact Sales Engineering before using a belt width greater than 24 in (610 mm) in a flat turning or spiral applications. 		
Additional Information		
<ul style="list-style-type: none"> • See "Belt Selection Process" (page 5) • See "Standard Belt Materials" (page 9) • See "Special Application Belt Materials" (page 9) • See "Friction Factors" (page 13) 		





A - Preferred direction for flat turning applications

Belt Data																
Belt Material	Standard Rod Material Ø 0.18 in (4.57 mm)	BS Straight Belt Strength Roller Width Spacing						Roller Indents		Curved Belt Strength	Temperature Range (continuous)		W Belt Weight			
											°F				°C	
		2 in	51 mm	3 in	76 mm	4 in	102 mm	in	mm		lb/ft	kg/m	lb/ft ²	kg/m ²		
Polypropylene	Acetal	700	1040	800	1190	900	1340	2	51	Contact Intralox Customer Service for curved belt strength calculations.	34 to 200	1 to 93	1.21	1.21		
								2.5 to 3.5	64 to 89		-50 to 200	-46 to 93	1.61	7.68		
Acetal	Nylon	1000	1490	1200	1780	1300	1940	2	51		Contact Intralox Customer Service for curved belt strength calculations.	34 to 220	1 to 104	1.04	5.11	
								2.5 to 3.5	64 to 89							
Polypropylene	Polypropylene	600	890	700	1040	800	1190	2	51			Contact Intralox Customer Service for curved belt strength calculations.				
								2.5 to 3.5	64 to 89							

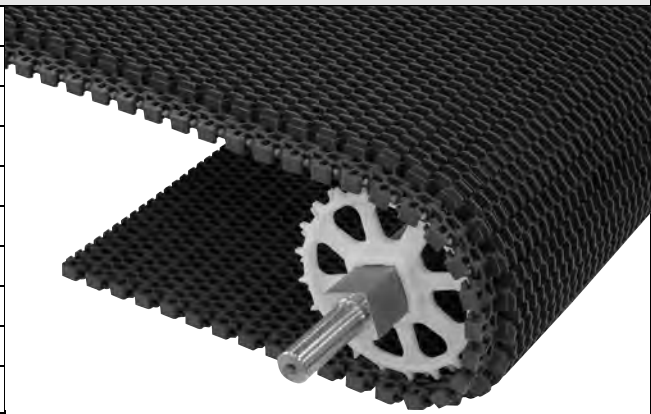
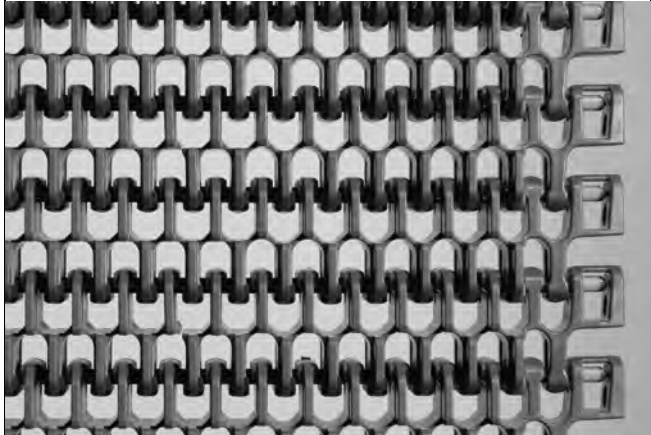
Radius Raised Rib		
	in	mm
Pitch	1.00	25.4
Minimum Width	4	102
Width Increments	0.50	12.7
Opening Size (approximate)	0.35 × 0.30	8.9 × 7.6
Open Area	42%	
Product Contact Area	18%	
Hinge Style	Open	
Drive Method	Hinge-driven	
Product Notes		
<ul style="list-style-type: none"> Contact Intralox for precise belt measurements and stock status before designing equipment or ordering a belt. Raised Rib belt deck is 0.5 in (12.7 mm) higher than the standard Series 2400 belt. Uses headless rods. Makes turns with an inside turn radius of 2.2 times the belt width. Facilitates smooth transfers of small packages with the addition of transfer plates. Raised Rib style permits ample airflow through the belt for cooling in food processing applications. Raised Rib deck has more beam strength than the standard Series 2400 belt, which can reduce retrofit costs in spirals. Works with standard Series 2400 wearstrips. Standard indent for Raised Rib belt deck is 1.12 in (28.6 mm). 		
Additional Information		
<ul style="list-style-type: none"> See “Belt Selection Process” (page 5) See “Standard Belt Materials” (page 9) See “Special Application Belt Materials” (page 9) See “Friction Factors” (page 13) 		

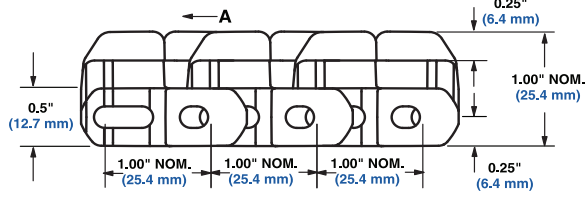

A -Preferred direction for flat turning applications

Belt Data								
Belt Material	Standard Rod Material Ø 0.18 in (4.57 mm)	<div style="font-size: 2em; font-weight: bold; color: blue;">BS</div> Straight Belt Strength		Curved Belt Strength	Temperature Range (continuous)		<div style="font-size: 2em; font-weight: bold; color: blue;">W</div> Belt Weight	
					°F	°C	lb/ft ²	kg/m ²
Polypropylene	Acetal	1200	1785	Contact Intralox Customer Service for curved belt strength calculations.	34 to 200	1 to 93	1.98	9.68
Acetal	Nylon	1700	2528		-50 to 200	-46 to 93	3.00	14.67
Polypropylene	Polypropylene ^a	1000	1487		34 to 220	1 to 104	1.92	9.39
HR Nylon	Nylon	1700	2530		-50 to 240	-46 to 116	2.5	12.25

a. Polypropylene rods can be installed in polypropylene belts when extra chemical resistance is required. Please note lower belt strength.

Radius Flat Top		
	in	mm
Pitch	1.00	25.4
Minimum Width	6	152
Width Increments	0.50	12.7
Open Area	0%	
Product Contact Area	66%	
Hinge Style	Open	
Drive Method	Hinge-driven	
Product Notes		
<ul style="list-style-type: none"> • Contact Intralox for precise belt measurements and stock status before designing equipment or ordering a belt. • The minimum nosebar diameter is 1.375 in (34.9 mm). • Sprocket drive system is designed to minimize wear and requires very low returnside tension. • Radius belt wearstrips are available. • Uses headless rods. • Contact Sales Engineering before using a belt width greater than 36 in (914 mm). • Patented belt design provides more support for sensitive products in a flat turning application. • Flat, closed surface successfully conveys small products that would fall through belts with open area. • Makes turns with an inside turn radius of 2.2 times the belt width. 		
Additional Information		
<ul style="list-style-type: none"> • See "Belt Selection Process" (page 5) • See "Standard Belt Materials" (page 9) • See "Special Application Belt Materials" (page 9) • See "Friction Factors" (page 13) 		

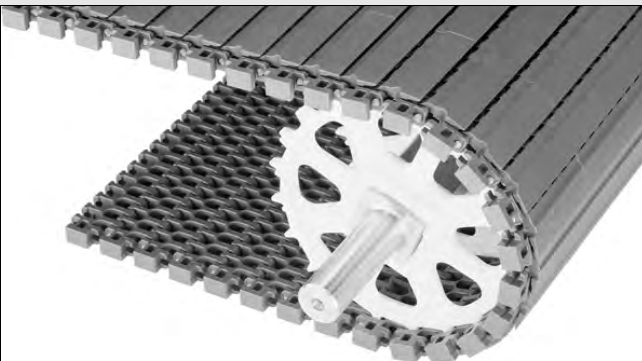
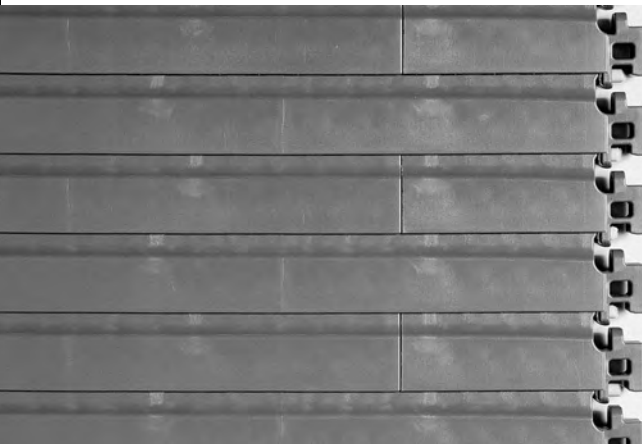
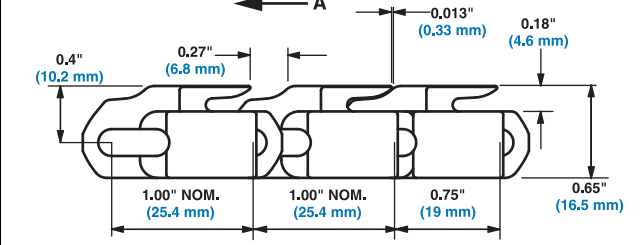



A -Preferred direction for flat turning applications

Belt Data								
Belt Material	Standard Rod Material Ø 0.18 in (4.57 mm)	BS Straight Belt Strength		Curved Belt Strength	Temperature Range (continuous)		W Belt Weight	
					°F	°C		
Acetal	Nylon	1700	2528	Contact Intralox Customer Service for curved belt strength calculations.	-50 to 200	-46 to 93	2.24	11.00

0.4" High Radius Friction Top

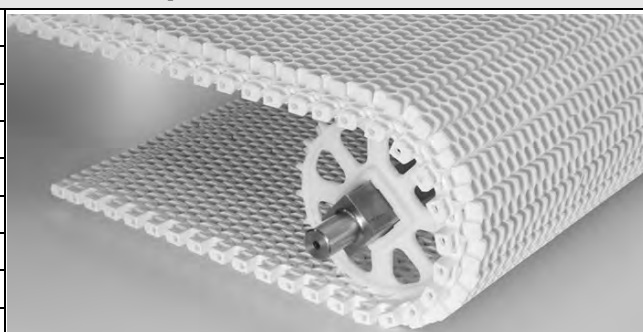
	in	mm
Pitch	1.00	25.4
Minimum Width	4	102
Width Increments	0.5	12.7
Opening Size (approximate)	0.35 x 0.30	8.9 x 7.6
Open Area	42%	
Product Contact Area	23%	
Hinge Style	Open	
Drive Method	Hinge-driven	



Product Notes

- **Contact Intralox for precise belt measurements and stock status before designing equipment or ordering a belt.**
- Uses headless rods.
- Makes turns with an inside turn radius of 2.2 times the belt width.
- The minimum nosebar diameter is 1.375 in (34.9 mm).
- Indent for friction surface is molded at 0.95 in (24.1 mm).
- Temperature, environmental conditions, and product characteristics affect the effective maximum degree of incline. Take these items into considerations when designing conveyor systems utilizing these belts.

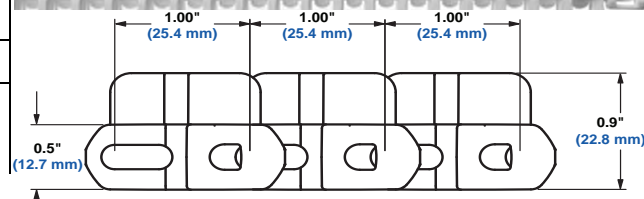
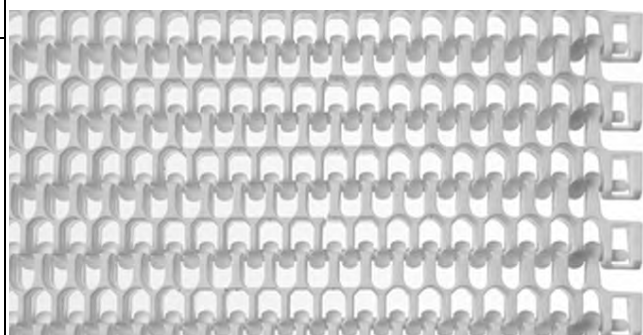

Additional Information

- See "Belt Selection Process" (page 5).
- See "Standard Belt Materials" (page 9).
- See "Special Application Belt Materials" (page 9).

Belt Data

Base Belt Material	Base/Friction Color	Standard Rod Material Ø 0.18 in (4.57 mm)	BS Belt Strength		Curved Belt Strength	Temperature Range (continuous)		W Belt Weight		Friction Top Hardness	Agency Acceptability	
			lb/ft	kg/m		°F	°C	lb/ft ²	kg/m ²		FDA (USA)	EU MC ^b
Polypropylene	White/White	Acetal	1200	1785	Contact Intralox Customer Service for curved belt strength calculations.	34 to 150	1 to 66	1.77	8.65	55 Shore A	a	c
Polypropylene	White/White	Polypropylene	1000	1488		34 to 150	1 to 66	1.69	8.25	55 Shore A	a	c
Polypropylene	High Performance FT Blue/Blue	Polypropylene	1200	1785		34 to 212	1 to 100	1.77	8.65	59 Shore A	a	c

- - Fully compliant

a - FDA Compliant with Restriction: Do not use in direct contact with fatty foods.

b - European Migration Certificate providing approval for food contact according to EU Regulation 10/2011.

c - EU compliant with Restriction: Do not use in direct contact with fatty foods.

Radius with Edge Bearing		
	in	mm
Pitch	1.00	25.4
Minimum Width (Bearings One Side)	7.5	191
Minimum Width (Bearings Both Sides)	10.5	267
Maximum Width	36	914
Width Increments	0.5	12.7
Opening Size (approximate)	0.35 x 0.30	8.9 x 7.6
Open Area	42%	
Product Contact Area	23%	
Hinge Style	Open	
Drive Method	Hinge-driven	



Product Notes	
<ul style="list-style-type: none"> • Contact Intralox for precise belt measurements and stock status before designing equipment or ordering a belt. • Edge bearings are only available for turning belts. • Bearings must be placed on the inside edge of the turn. • Bearings are available on one side (for belts that turn in only one direction) or on both sides (for belts that turn in both directions). • Both flush edge and hold down guide edge are available for belts that have bearings on only one side and must be placed on the outside edge of the turn. • Bearings must be configured in every other row of the belt. • Bearings are stainless steel. • Bearings are retained in the belt using a plastic pin. • Rod retention allows for easier insertion and removal of rods. • Uses headless rods. • Designed for radius applications with a turn radius of 2.2 times the belt width. • The Intralox Engineering Program should be used to determine if the Edge Bearing is suitable for your application. 	

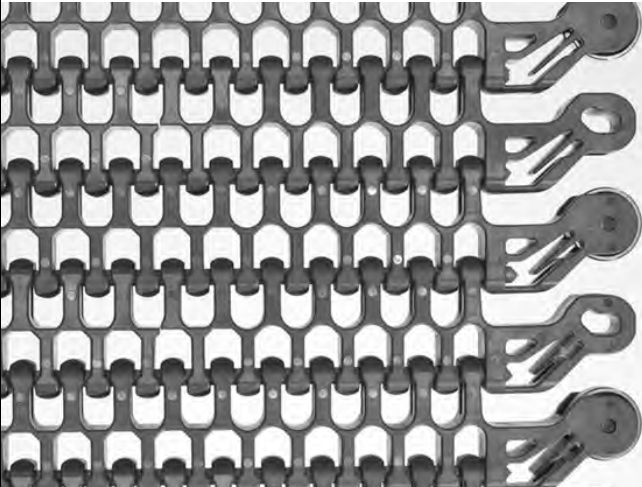

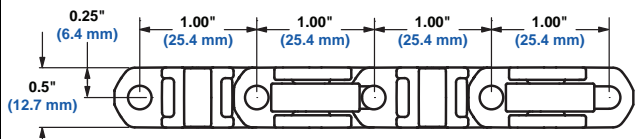

A - Preferred direction for flat turning applications

Belt Data								
Base Belt Material	Standard Rod Material Ø 0.18 in (4.6 mm)	BS Straight Belt Strength		Curved Belt Strength	Temperature Range (continuous)		W Belt Weight	
		lb/ft	kg/m		°F	°C	lb/ft ²	kg/m ²
Acetal	Nylon	1700	2530	Contact Intralox Customer Service for curved belt strength calculations.	0 to 200	-18 to 93	1.59	7.76

Flush Grid High Deck with Edge Bearing

	in	mm
Pitch	1.00	25.4
Minimum Width (Bearings One Side)	7.5	191
Minimum Width (Bearings Both Sides)	10.5	267
Maximum Width	36	914
Width Increments	0.5	12.7
Opening Size (approximate)	0.35 x 0.30	8.9 x 7.6
Open Area	42%	
Product Contact Area	23%	
Hinge Style	Open	
Drive Method	Hinge-driven	

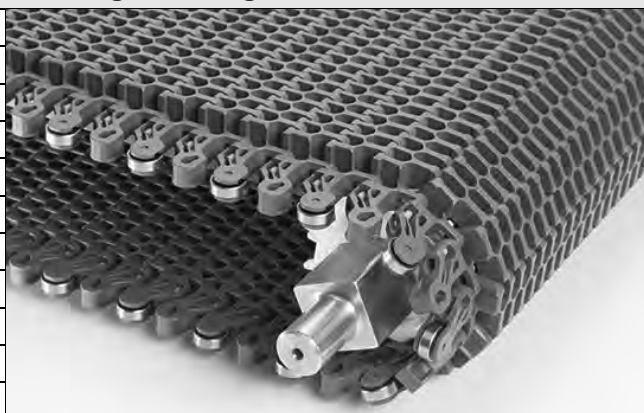

Product Notes

- Contact Intralox for precise belt measurements and stock status before designing equipment or ordering a belt.
- Flush Grid High Deck with Edge Bearing is 0.4 in (10 mm) higher than standard S2400 belt.
- Standard indent is 1.88 in (47.75 mm).
- Edge bearings are only available for turning belts.
- Bearings must be placed on the inside edge of the turn.
- Bearings are available on one side (for belts that turn in only one direction) or on both sides (for belts that turn in both directions).
- Bearings must be configured in every other row of the belt.
- Bearings are stainless steel and are recommended for dry applications only.
- Plastic pins retain bearings in the belt.
- Rod retention allows for easier insertion and removal of rods.
- Uses headless rods.
- Designed for radius applications with a turn radius of 2.2 times the belt width.
- Flush Grid High Deck with Edge Bearing has more beam strength than the standard S2400 belt, which can reduce retrofit costs in radius applications.
- Use the Intralox Engineering Program to determine if the Edge Bearing is suitable for your application.

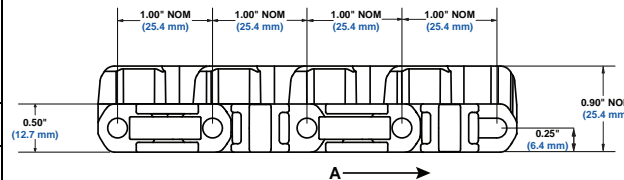
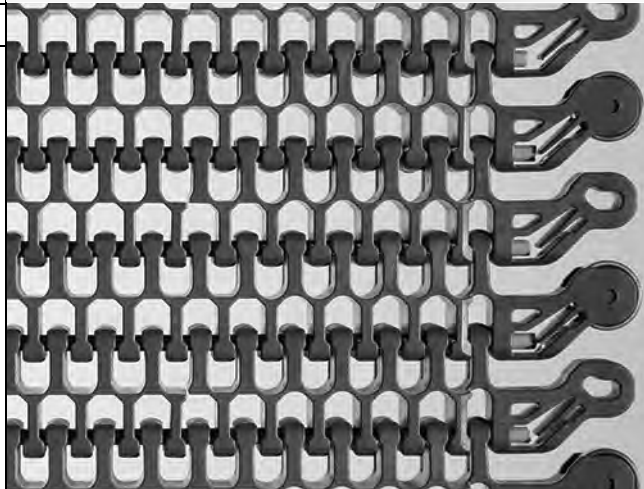

A - Preferred direction for flat turning applications

Additional Information

- See "Belt Selection Process" (page 5)
- See "Standard Belt Materials" (page 9)
- See "Friction Factors" (page 13)

Belt Data

Base Belt Material	Standard Rod Material Ø 0.18 in (4.6 mm)	BS		Curved Belt Strength	Temperature Range (continuous) ^a		W		
		Straight Belt Strength			°F	°C	Belt Weight		
		lb/ft	kg/m				lb/ft ²	kg/m ²	
Acetal	Nylon	1700	2530	Contact Intralox Customer Service for curved belt strength calculations.		0 to 200	-18 to 93	2.83	13.82

a. Sideflexing applications should not exceed 180°F (82°C).

Radius Flush Grid with Load-Sharing Edge		
	in	mm
Pitch	1.00	25.4
Minimum Width	10.5	266.7
Maximum Width	36	914
Width Increments	0.5	12.7
Opening Size (approximate)	0.35 x 0.30	8.9 x 7.6
Open Area	42%	
Product Contact Area	23%	
Hinge Style	Open	
Drive Method	Hinge-driven	
Product Notes		
<ul style="list-style-type: none"> • Contact Intralox for precise belt measurements and stock status before designing equipment or ordering a belt. • Uses headless rods. • Designed for radius applications with a minimum turn radius of 2.2 times the belt width. • Available with hold down guides. • The minimum nosebar diameter is 1.5 in (38 mm) with hold down guides and 1.375 in (34.9 mm) without hold down guides. • The Intralox Engineering Program will help predict the strength requirement of ost radius and low-tension capstan drive spiral applications, ensuring that belt is strong enough for the application. • Belt openings pass straight through belt, making it easy to clean. • Sprocket drive system is designed to minimize wear and requires ver low return side tension. • Radius belt wearstrips are available. • Load-Sharing™ belt edge improves how the load is shared and minimizes fatigue failure in various areas of the belt. • Flush edge design features an extension to reduce the opening size. • Designed for radius applications with a turn radius of 2.2 times the belt width. • Temperature, environmental conditions, and product characteristics affect the effective maximum degree of incline. Take the items into consideration when designing conveyor systems utilizing these belts. 		
Additional Information		
<ul style="list-style-type: none"> • See “Belt Selection Process” (page 5) • See “Standard Belt Materials” (page 9) • See “Friction Factors” (page 13) 		

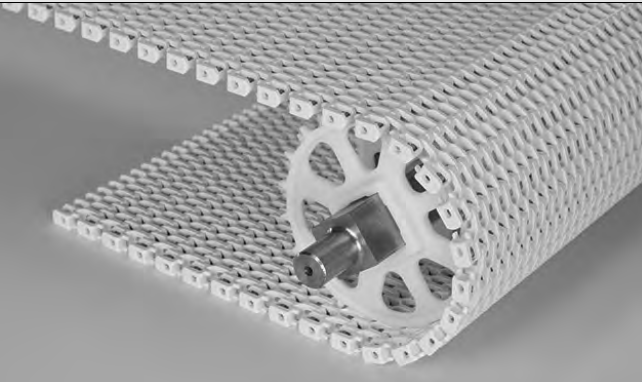
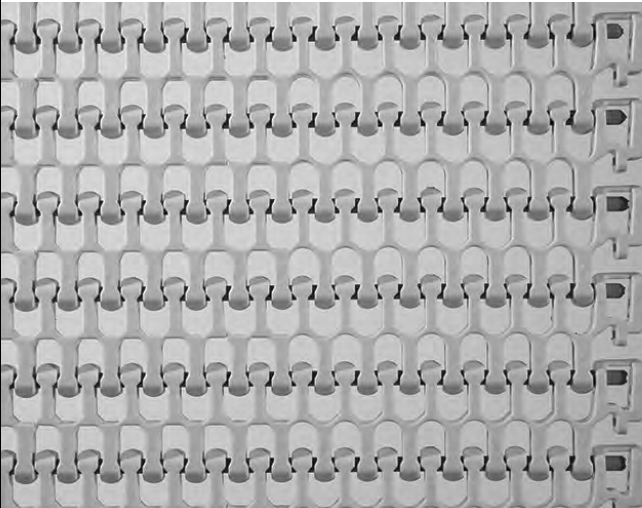
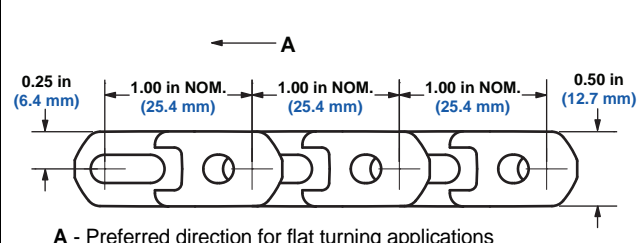



Belt Data								
Base Belt Material	Standard Rod Material Ø 0.18 in (4.6 mm)	BS Straight Belt Strength lb/ft kg/m		Curved Belt Strength	Temperature Range (continuous) ^a		W Belt Weight lb/ft ² kg/m ²	
					°F	°C	lb/ft ²	kg/m ²
Polypropylene	Acetal	1200	1790	Contact Intralox Customer Service for curved belt strength calculations.	34 to 200	1 to 93	1.10	5.37
Acetal	Nylon	1700	2530		-50 to 200	-46 to 93	1.59	7.76
Polypropylene	Polypropylene	1000	1490		34 to 200	1 to 104	1.04	5.10

a. Sideflexing applications should not exceed 180°F (82°C).

Flush Grid High Deck with Load-Sharing Edge

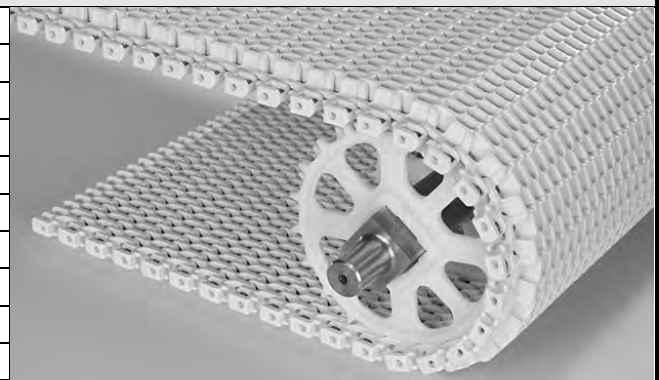
	in	mm
Pitch	1.00	25.4
Minimum Width	10.5	266.7
Maximum Width	36	914
Width Increments	0.5	12.7
Opening Size (approximate)	0.35 x 0.30	8.9 x 7.6
Open Area	42%	
Product Contact Area	23%	
Hinge Style	Open	
Drive Method	Hinge-driven	



Product Notes

- **Contact Intralox for precise belt measurements and stock status before designing equipment or ordering a belt.**
- Uses headless rods.
- Designed for radius applications with a minimum turn radius of 2.2 times the belt width.
- Flush Grid High Deck with Load Sharing Edge is 0.4 in (10 mm) higher than the standard S2400 belt.
- The Intralox Engineering Program will help predict the strength requirement of most radius and low-tension capstan drive spiral applications, ensuring that belt is strong enough for the application.
- Belt openings pass straight through belt, making it easy to clean.
- Sprocket-driven system is designed to minimize wear and requires very low return side tension.
- Works with standard Series 2400 wearstrip.
- Load-Sharing™ belt edge improves how the load is shared and minimizes fatigue failure in various areas of the belt.
- Flush edge design features an extension to reduce the opening size.
- Standard indent for Flush Grid High Deck with Load Sharing Edge is 0.875 in (22.2 mm).

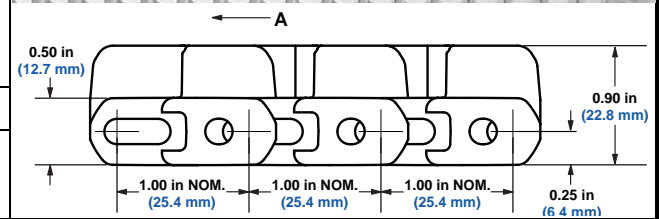
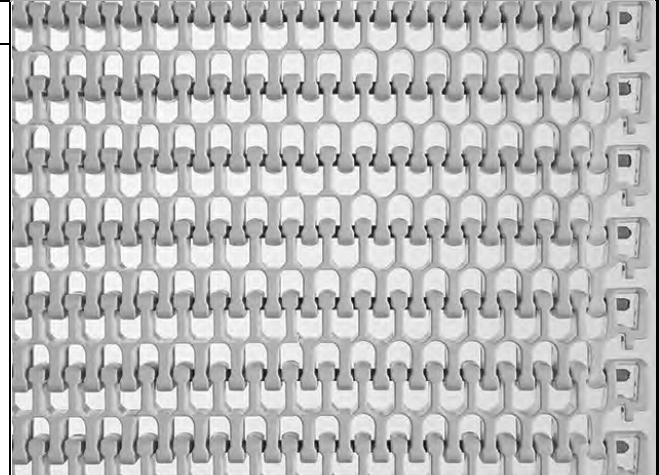

Additional Information

- See "Belt Selection Process" (page 5)
- See "Standard Belt Materials" (page 9)
- See "Friction Factors" (page 13)

Belt Data

Base Belt Material	Standard Rod Material Ø 0.18 in (4.6 mm)	BS Straight Belt Strength		Curved Belt Strength	Temperature Range (continuous) ^a		W Belt Weight	
		lb/ft	kg/m		°F	°C	lb/ft ²	kg/m ²
Polypropylene	Acetal	1200	1785	Contact Intralox Customer Service for curved belt strength calculations.	34 to 200	1 to 93	1.90	9.28
Acetal	Nylon	1700	2530		-50 to 200	-46 to 93	2.83	13.82
Polypropylene	Polypropylene	1000	1487		34 to 200	1 to 104	1.84	8.99

a. Sideflexing applications should not exceed 180°F (82°C).

Radius Flush Grid Friction Top 2.2 with Load-Sharing Edge

	in	mm
Pitch	1.00	25.4
Minimum Width	10.5	266.7
Maximum Width	36.0	914.0
Opening Size (approximate)	0.35 x 0.30	8.9 x 7.6
Open Area	42%	
Product Contact Area	23%	
Hinge Style	Open	
Drive Method	Hinge-driven	



Product Notes

- **Contact Intralox for precise belt measurements and stock status before designing equipment or ordering a belt.**
- This belt uses headless rods.
- Flush edge design features an extension to reduce the opening size.
- Load-Sharing™ belt edge improves how the load is shared and minimizes fatigue failure in various areas of the belt.
- Friction top available in grey PP with grey rubber and white PP with white rubber.
- Belt openings pass straight through belt, making it easy to clean.
- Temperature, environmental conditions, and product characteristics affect the effective maximum degree of incline. Take the items into consideration when designing conveyor systems utilizing these belts.
- The Intralox Engineering Program will help predict the strength requirement of most radius applications, ensuring that belt is strong enough for the application.
- Sprocket drive system is designed to minimize wear and requires very low return side tension.
- Available with hold down guides.
- Radius belt wearstrips are available.
- Indent for friction surface is molded at 1.125 in (28.6 mm).
- Designed for radius applications with a minimum turn radius of 2.2 times the belt width.
- The minimum nosebar diameter is 1.5 in (38 mm) with hold down guides and 1.375 in (34.9 mm) without hold down guides.

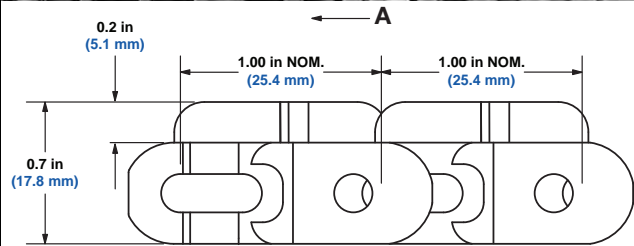
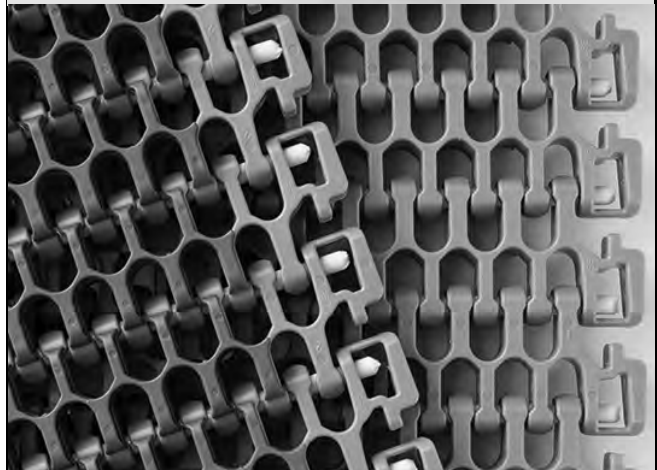

Additional Information

- See "Belt Selection Process" (page 5)
- See "Standard Belt Materials" (page 9)
- See "Friction Factors" (page 13)

Belt Data

Base Belt Material	Base/Friction Color	Standard Rod Material Ø 0.18 in (4.57 mm)	BS Belt Strength		Temperature Range (continuous)		W Belt Weight		Friction Top Hardness	Agency Acceptability		
			lb/ft	kg/m	°F	°C	lb/ft²	kg/m²		FDA (USA)	EU MC ^b	
Polypropylene	Grey/Grey	Acetal	1200	1790	34 to 150		1 to 66	1.35	6.59	64 Shore A		
Polypropylene	White/White	Acetal	1200	1790	34 to 150		1 to 66	1.35	6.59	55 Shore A	a	c
Polypropylene	Grey/Grey	Polypropylene	1000	1490	34 to 150		1 to 66	1.29	6.30	64 Shore A		
Polypropylene	White/White	Polypropylene	1000	1490	34 to 150		1 to 66	1.29	6.30	55 Shore A	a	c

a - FDA Compliant with Restriction: Do not use in direct contact with fatty foods.

b - European Migration Certificate providing approval for food contact according to EU Regulation 10/2011.

c - EU compliant with Restriction: Do not use in direct contact with fatty foods.

Mold to Width Radius Flush Grid Friction Top 2.2 with Load-Sharing Edge

	in	mm
Pitch	1.00	25.4
Minimum Width	4.0	101.6
Opening Size (approximate)	0.35 x 0.30	8.9 x 7.6
Open Area	42%	
Hinge Style	Open	
Drive Method	Hinge-driven	

Product Notes

- **Contact Intralox for precise belt measurements and stock status before designing equipment or ordering a belt.**
- Available in 4-in (101.6-mm), 6-in (152.4-mm), 8-in (203.2-mm), and 10-in (254-mm) widths.
- Available with hold down guides. See page 332 of the 2018 Engineering Manual for details.
- Friction Top available in grey PP with grey rubber and white PP with white rubber.
- Indent for friction surface on 4-in (101.6-mm) and 6-in (152.4-mm) widths is molded at 0.70 in (17.78 mm).
- Indent for friction surface on 8-in (203.2-mm) and 10-in (254-mm) widths is molded at 0.95 in (24.1 mm).
- Maximum number of sprockets for 4-in (101.6-mm) belts without hold down guides is two. Maximum number of sprockets for 4-in (101.6-mm) belts with hold down guides is one.
- Maximum number of sprockets for 6-in (152.4-mm) belts without hold down guides is four. Maximum number of sprockets for 6-in (152.4-mm) belts with hold down guides is three.
- Maximum number of sprockets for 8-in (203.2-mm) belts with and without hold down guides is five.
- Maximum number of sprockets for 10-in (254-mm) belts with and without hold down guides is seven.
- The smallest pitch diameter sprocket that can be used with hold down guides is 5.1 in (130 mm).
- Designed for sideflexing applications with a standard turn ratio of 2.2 times the belt width.
- The minimum nosebar diameter for belts without hold down guides is 1.375 in (34.9 mm). The minimum nosebar diameter for belts with hold down guides is 1.50 in (38.1 mm).
- Load-Sharing™ belt edge improves how the load is shared and minimizes fatigue failure in various areas of the belt.
- Radius belt wearstrips are available.
- Uses headed rods.
- Flush edge design features an extension to reduce the opening size.
- The Intralox Engineering Program helps predict the strength requirement of most radius applications, ensuring that the belt is strong enough for the application.
- Temperature, environmental conditions, and product characteristics affect the effective maximum degree of incline. Consider these factors when designing conveyor systems utilizing these belts.

Additional Information

- See "Belt Selection Process" (page 5)
- See "Standard Belt Materials" (page 9)
- See "Special Application Belt Materials" (page 9)

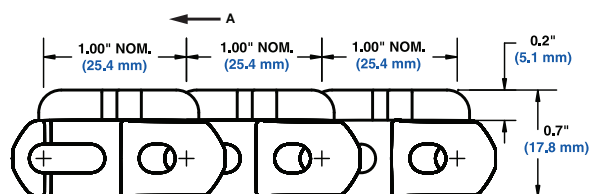
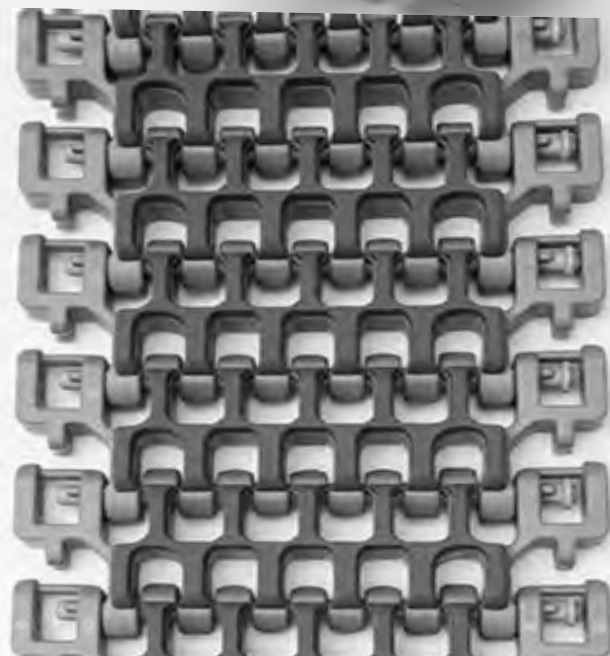

A - Preferred direction for flat turning applications

Belt Data

Base Belt Material	Standard Rod Material Ø0.18 in (4.6 mm)		BS Straight Belt Strength lb (kg)				Curved Belt Strength	Temperature Range (continuous)		W Belt Weight lb/ft (kg/m)			
			4.0 (101.6)	6.0 (152.4)	8.0 (203.2)	10.0 (254)		F°	C°	4.0 (101.6)	6.0 (152.4)	8.0 (203.2)	10.0 (254)
Polypropylene	Nylon	without hold down guides	400 (181)	600 (272)	800 (363)	1000 (454)	Contact Intralox Customer Service for curved belt strength calculations.	34 to 150	1 to 66	0.39 (0.58)	0.60 (0.89)	0.82 (1.22)	1.01 (1.50)
		with hold down guides	242 (110)	600 (272)	800 (363)	1000 (454)		34 to 150	1 to 66	0.43 (0.64)	0.65 (0.978)	0.86 (1.28)	1.06 (1.58)

Mold to Width Radius Flush Grid 2.2 with Load-Sharing Edge

	in	mm
Pitch	1.00	25.4
Minimum Width	4.0	101.6
Opening Size (approximate)	0.35 x 0.30	8.9 x 7.6
Open Area	42%	
Hinge Style	Open	
Drive Method	Hinge-driven	

Product Notes

- **Contact Intralox for precise belt measurements and stock status before designing equipment or ordering a belt.**
- Available in 4-in (101.6-mm), 6-in (152.4-mm), 8-in (203.2-mm), and 10-in (254-mm) widths.
- Available with hold down guides. See page 331 of the 2017 Engineering Manual for details.
- Maximum number of sprockets for 4-in (101.6-mm) belts without hold down guides is two. Maximum number of sprockets for 4-in (101.6-mm) belts with hold down guides is one.
- Maximum number of sprockets for 6-in (152.4-mm) belts without hold down guides is four. Maximum number of sprockets for 6-in (152.4-mm) belts with hold down guides is three.
- Maximum number of sprockets for 8-in (203.2-mm) belts with and without hold down guides is five.
- Maximum number of sprockets for 10-in (254-mm) belts with and without hold down guides is seven.
- Designed for sideflexing applications with a standard turn ratio of 2.2 times the belt width.
- The minimum nosebar diameter for belts without hold down guides is 1.375 in (34.9 mm). The minimum nosebar diameter for belts with hold down guides is 1.50 in (38.1 mm).
- Load-Sharing™ belt edge improves how the load is shared and minimizes fatigue failure in various areas of the belt.
- Radius belt wearstrips are available.
- Uses headed rods.
- Flush edge design features an extension to reduce the opening size.
- The Intralox Engineering Program will help predict the strength requirement of most radius applications, ensuring that the belt is strong enough for the application.
- Temperature, environmental conditions, and product characteristics affect the effective maximum degree of incline. Take the items into consideration when designing conveyor systems utilizing these belts.

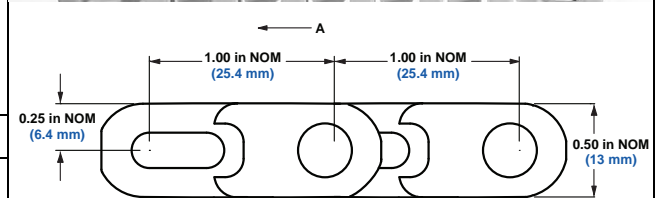
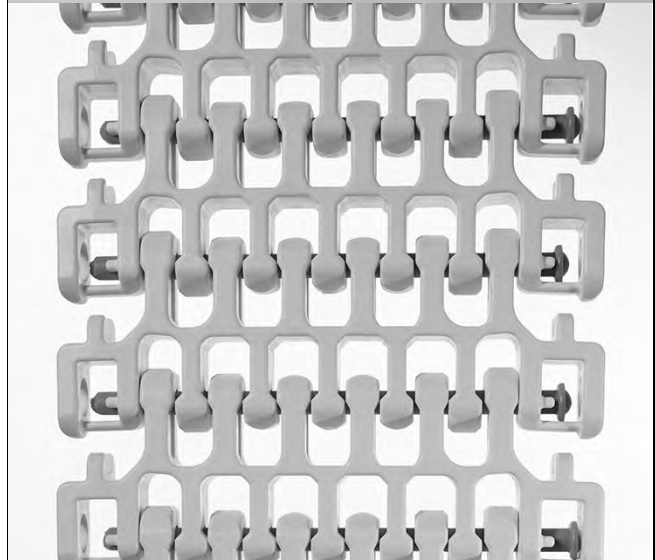
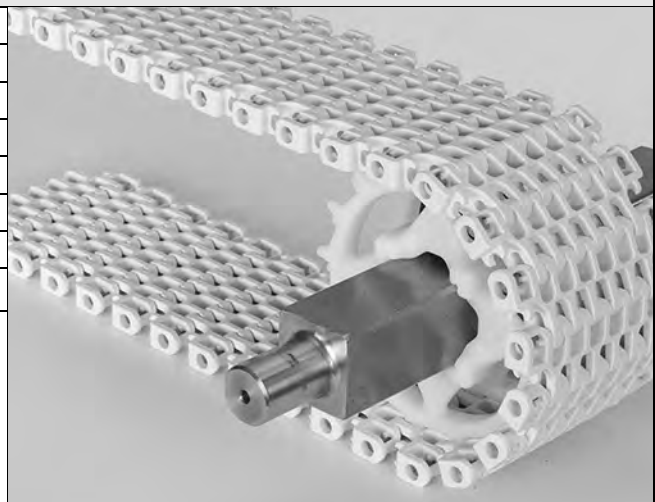

A - Preferred direction for flat turning applications

Additional Information

- See "Belt Selection Process" (page 5)
- See "Standard Belt Materials" (page 9)
- See "Special Application Belt Materials" (page 9)

SECTION 2

2400

Belt Data

Base Belt Material	Standard Rod Material Ø 0.18 in (4.6 mm)		BS Straight Belt Strength lb (kg)				Curved Belt Strength		Temperature Range (continuous)		W Belt Weight lb/ft (kg/m)			
			4 in (101.6)	6 in (152.4)	8 in (203.2)	10 in (254)	°F	°C	4 in (101.6)	6 in (152.4)	8 in (203.2)	10 in (254)		
Acetal	Nylon	without hold down guides	484 (220)	850 (386)	1133 (514)	1417 (643)	Contact Intralox Customer Service for curved belt strength calculations.	-50 to 200	-46 to 93	0.57 (0.85)	0.89 (1.32)	1.19 (1.77)	1.50 (2.23)	
		with hold down guides	242 (110)	726 (329)	1133 (514)	1417 (643)		-50 to 200	-46 to 93	0.64 (0.95)	0.96 (1.42)	1.26 (1.88)	1.56 (2.32)	
Polypropylene	Nylon	without hold down guides	400 (181)	600 (272)	800 (363)	1000 (454)		34 to 220	1 to 104	0.39 (0.58)	0.60 (0.89)	0.82 (1.22)	1.01 (1.50)	
		with hold down guides	242 (110)	600 (272)	800 (363)	1000 (454)		34 to 220	1 to 104	0.43 (0.64)	0.65 (0.978)	0.86 (1.28)	1.06 (1.58)	

Sprocket and Support Quantity Reference				
Belt Width Range ^a		Minimum Number of Sprockets Per Shaft ^b	Wearstrips ^c	
in.	mm		Carryway	Returnway
4	102	1	2	2
5	127	2	2	2
6	152	2	2	2
7	178	2	2	2
8	203	2	2	2
10	254	2	3	2
12	305	3	3	2
14	356	3	3	3
15	381	5	3	3
16	406	5	3	3
18	457	5	3	3
20	508	5	4	3
24	610	5	4	3
30	762	7	5	4
32	813	7	5	4
36	914	7	5	4
42	1067	9	6	5
48	1219	11	7	5
For Other Widths, Use Odd Number of Sprockets at Maximum 6 in. (152 mm) \varnothing Spacing			Maximum 9 in. (229 mm) \varnothing Spacing	Maximum 12 in. (305 mm) \varnothing Spacing

- If your belt width exceeds a number listed in the table, please refer to the sprocket and support material minimums for the next larger width range listed. Belts are available in 0.50 in. (12.7 mm) increments beginning with minimum width of 4 in. (102 mm). **If the actual width is critical, consult Customer Service.**
- These are the minimum number of sprockets. Additional sprockets may be required for heavily loaded applications. See Retainer Rings/Center Sprocket Offset chart on page 410 for lock down location.
- The number of wearstrips given does not include the hold down wearstrip.

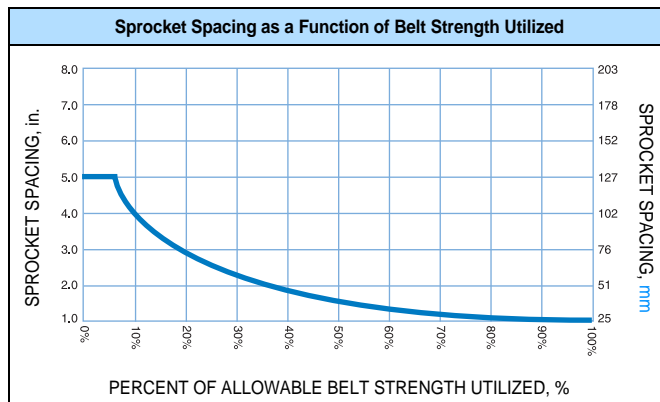
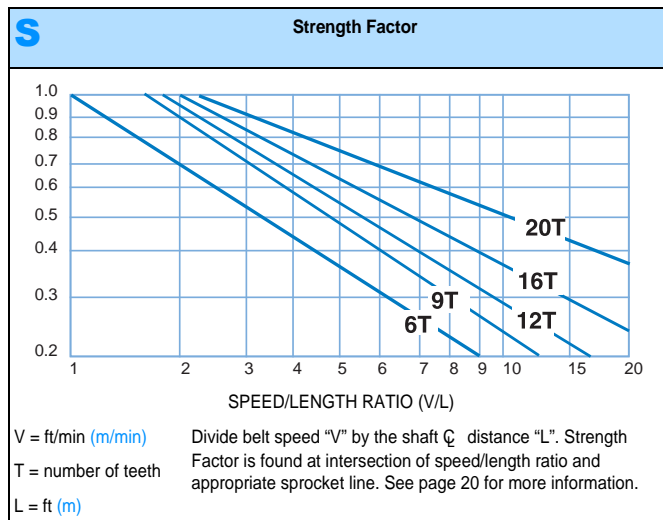

Molded Sprocket^a										
No. of Teeth (Chordal Action)	Nom. Pitch Dia. in	Nom. Pitch Dia. mm	Nom. Outer Dia. in	Nom. Outer Dia. mm	Nom. Hub Width in	Nom. Hub Width mm	Available Bore Sizes			
							U.S. Sizes		Metric Sizes	
							Round in ^b	Square in	Round mm ^b	Square mm
6 ^{cd} (13.40%)	2.0	51	2.0	51	.54	14	3/4		20	
9 ^{cd} (6.03%)	2.9	74	2.9	74	1.0	25	1	1	25	25
12 (3.41%)	3.9	99	4.0	102	1.0	25	1 to 1-1/2	1.5 ^d	25 to 40	40 ^d
16 (1.92%)	5.1	130	5.2	132	1.0	25	1 to 1-1/2	1.5	25 to 40	40
20 (1.23%)	6.4	163	6.4	163	1.0	25	1 to 1-1/2	1.5	25 to 40	40



- a. Contact Customer Service for lead times. When using Polyurethane sprockets, the Belt Strength for belts rated over 750 lb/ft (1120 kg/m) will be de-rated to 750 lb/ft (1120 kg/m) and all other belts will maintain their published rating. The temperature range for Polyurethane sprockets is 0 °F (-18 °C) to 120 °F (49 °C). Contact Customer Service for availability of Polyurethane sprockets.
- b. Imperial key sizes on round bore sprockets conform to ANSI standard B17.1-1967 (R1989) and metric key sizes conform to DIN standard 6885.
- c. The 2.0 in (51 mm) Pitch Diameter 6 tooth sprocket and the 2.9 in (74 mm) Pitch Diameter 9 tooth sprocket have a recommended belt pull of 60 lb/sprocket (27 kg/sprocket).
- d. Do not use this sprocket with Hold Down Guides.

Split Ultra Abrasion Resistant Polyurethane Sprocket^a										
No. of Teeth (Chordal Action)	Nom. Pitch Dia. in	Nom. Pitch Dia. mm	Nom. Outer Dia. in	Nom. Outer Dia. mm	Nom. Hub Width in	Nom. Hub Width mm	Available Bore Sizes			
							U.S. Sizes		Metric Sizes	
							Round in	Square in	Round mm	Square mm
16 (1.92%)	5.1	130	5.2	132	1.0	25		1.5 ^b		40 ^b
20 (1.23%)	6.4	163	6.4	163	1.0	25		1.5		40



- a. Contact Customer Service for lead times. When using Polyurethane sprockets, the Belt Strength for belts rated over 750 lb/ft (1120 kg/m) will be de-rated to 750 lb/ft (1120 kg/m) and all other belts will maintain their published rating. The temperature range for Polyurethane sprockets is 0 °F (-18 °C) to 120 °F (49 °C). Contact Customer Service for availability of Polyurethane sprockets.
- b. FDA approved sprockets are available.

Nylon (FDA) Sprocket^a										
No. of Teeth (Chordal Action)	Nom. Pitch Dia. in	Nom. Pitch Dia. mm	Nom. Outer Dia. in	Nom. Outer Dia. mm	Nom. Hub Width in	Nom. Hub Width mm	Available Bore Sizes			
							U.S. Sizes		Metric Sizes	
							Round in ^b	Square in	Round mm ^b	Square mm
12 (3.41%)	3.9	99	4	102	1.0	25	1, 1-1/4	1.5 ^c		
16 (1.92%)	5.1	130	5.2	132	1.0	25	1-1/4			40
20 (1.23%)	6.4	163	6.4	163	1.0	25		1.5		



- a. **Contact Customer Service for lead times.**
- b. Imperial key sizes on round bore sprockets conform to ANSI standard B17.1-1967 (R1989) and metric key sizes conform to DIN standard 6885.
- c. Do not use this sprocket with Hold Down Guides.

Acetal Split Sprocket ^a										
No. of Teeth (Chordal Action)	Nom. Pitch Dia. in	Nom. Pitch Dia. mm	Nom. Outer Dia. in	Nom. Outer Dia. mm	Nom. Hub Width in	Nom. Hub Width mm	Available Bore Sizes			
							U.S. Sizes		Metric Sizes	
							Round in ^b	Square in	Round mm ^b	Square mm
12 (3.41%)	3.9	99	3.9	99	1.0	25	1-1/4	1.5 ^c		

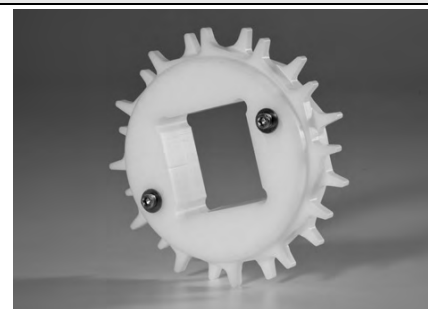

- a. Contact Customer Service for lead times.
 b. Imperial key sizes on round bore sprockets conform to ANSI standard B17.1-1967 (R1989) and metric key sizes conform to DIN standard 6885.
 c. Do not use this sprocket with Hold Down Guides.

Glass Filled Nylon Sprocket ^a										
No. of Teeth (Chordal Action)	Nom. Pitch Dia. in	Nom. Pitch Dia. mm	Nom. Outer Dia. in	Nom. Outer Dia. mm	Nom. Hub Width in	Nom. Hub Width mm	Available Bore Sizes			
							U.S. Sizes		Metric Sizes	
							Round in ^b	Square in	Round mm ^b	Square mm
16 (1.92%)	5.1	130	5.2	132	1.0	25		1.5		40



- a. Contact Customer Service for lead times.
 b. Imperial key sizes on round bore sprockets conform to ANSI standard B17.1-1967 (R1989) and metric key sizes conform to DIN standard 6885.

Glass Filled Nylon Split Sprocket ^a										
No. of Teeth (Chordal Action)	Nom. Pitch Dia. in	Nom. Pitch Dia. mm	Nom. Outer Dia. in	Nom. Outer Dia. mm	Nom. Hub Width in	Nom. Hub Width mm	Available Bore Sizes			
							U.S. Sizes		Metric Sizes	
							Round in ^b	Square in	Round mm ^b	Square mm
16 (1.92%)	5.1	130	5.2	132	1.5	38	1-1/4		30 40	



- a. Contact Customer Service for lead times.
 b. Imperial key sizes on round bore sprockets conform to ANSI standard B17.1-1967 (R1989) and metric key sizes conform to DIN standard 6885.

HR Nylon EZ Clean™ Sprockets ^a										
No. of Teeth (Chordal Action)	Nom. Pitch Dia. in	Nom. Pitch Dia. mm	Nom. Outer Dia. in	Nom. Outer Dia. mm	Nom. Hub Width in	Nom. Hub Width mm	Available Bore Sizes			
							U.S. Sizes		Metric Sizes	
							Round in ^b	Square in	Round mm ^b	Square mm
16 (1.92%)	5.1	130	5.2	132	1.0	25				40



a. Contact Customer Service for lead times.

b. Imperial key sizes on round bore sprockets conform to ANSI standard B17.1-1967 (R1989) and metric key sizes conform to DIN standard 6885.

Finger Transfer Plates			
Available Widths		Number of Fingers	Available Materials
in	mm		
4	102	16	Acetal

Note: Designed to be used with Series 2400 Raised Rib belts to eliminate product transfer and tipping problems.

Note: The fingers extend between the belt's ribs allowing a smooth continuation of the product flow as the belt engages its sprockets.

Note: Finger transfer plates are installed easily on the conveyor frame with conventional fasteners.

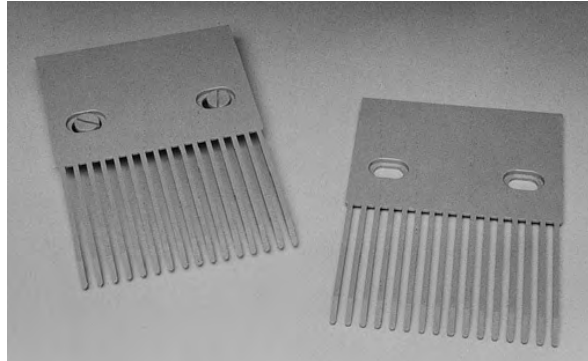

No-Cling Flights		
Available Flight Height		Available Materials
in	mm	
3.0	76	Polypropylene, Polyethylene, Acetal

Note: Minimum indent is 1.125 in (29 mm).

Note: Series 2400 flights do not have bottom hold down guides, but can be used with the bottom hold down belt style, with a minimum flight spacing of 4 in (102 mm).

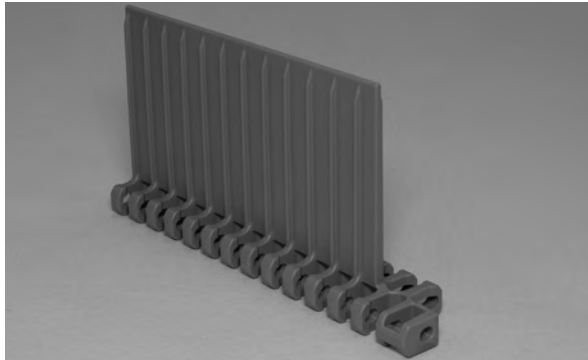

Universal Sideguards		
Available Sideguard Height		Available Materials
in	mm	
1.0	25	Polypropylene, Acetal
3.0	76	

Note: Similar in design and function to other standard, overlapping Intralox sideguards. It is an integral part of the belt, fastened by hinge rods. It adds versatility to the Series 2400 belt when used in multiple rows for separating product.

Note: It is easily cleanable and is suitable for food applications (FDA accepted).

Note: A minimum 1.5 inch (38 mm) indent is required for the 2.2 turn ratio and a 3.0 inch (76 mm) indent for the 1.7 turn ratio with this style sideguard.

Note: Standard sideguard orientation is angled inward toward the product (product friendly). If needed, sideguards can be angled outward toward the conveyor.



Hold Down Guides (2.2 Only)

- Materials available: polypropylene, acetal, HR nylon
- Hold down guides are on the bottom of the belt for use when the belt edges need to be clear. Also available on friction top modules.
- Hold down guides provide the ability to run two belts next to each other without a large gap in between.
- The belt edge is smooth for reduced friction, and is relatively thick to provide wear resistance and protection for the rod retention.
- The minimum nosebar diameter is 1.5 in (38.1 mm)
- Hold down guides cannot be used with 2 in and 2.9 in pitch diameter sprockets or 3.9 in pitch diameter square bore sprockets.
- Other sprocket PDs with large bores may not produce enough clearance between the hold down guide and shaft. Subtracting bore size from the PD easily identifies these sprockets. If the number is less than 2.0 in (51 mm), this sprocket cannot be used with hold down guides.

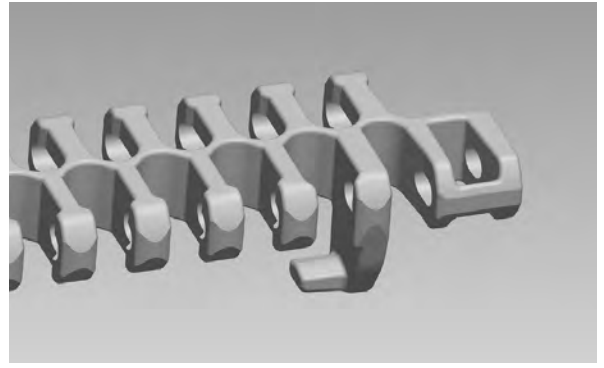

Front view

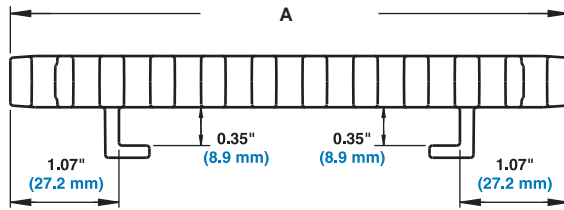

A - Belt width

Note: Hold down guides are not recommended for low-tension capstan drive spiral applications.

Fig. 2-3 SERIES 2400 HOLD DOWN GUIDES FOR FLAT TURNS

Side view

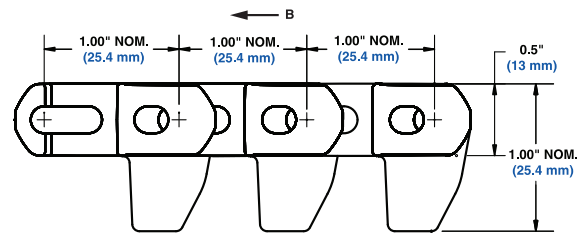

B - Preferred direction for flat turning applications

Conveyor Frame Dimensions

Regardless of type or configuration, all conveyors using Intralox belts have some basic dimensional requirements. Specifically, dimensions "A", "B", "C" and "E" listed below should be implemented in any design.

For general applications and applications where end transfer of tip-sensitive product is not critical, use the "A" dimension at the bottom of the range.

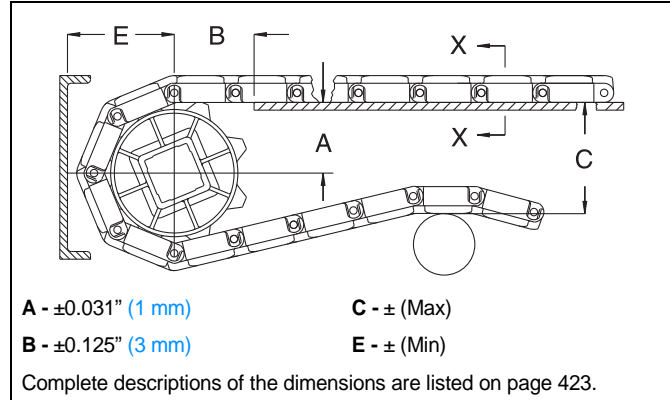

Sprocket Description		A		B		C		E		
Pitch Diameter		No. Teeth	Range (Bottom to Top)		in.	mm	in.	mm	in.	mm
in.	mm		in.	mm						
SERIES 2400 RADIUS FLUSH GRID - STRAIGHT EDGE, HOLD DOWN GUIDES										
2.0 ^a	51 ^a	6	0.62-0.75	16-19	1.22	31	2.00	51	1.31	33
2.9 ^a	74 ^a	9	1.12-1.21	28-31	1.51	38	2.92	74	1.77	45
3.9	99	12	1.62-1.68	41-43	1.86	47	3.86	98	2.24	57
5.1	130	16	2.26-2.31	57-59	2.11	54	5.13	130	2.88	73
6.4	163	20	2.91-2.95	74-75	2.31	59	6.39	162	3.51	89
SERIES 2400 RADIUS FLUSH GRID HIGH DECK, 0.4" HIGH RADIUS FRICTION TOP										
2.0 ^a	51 ^a	6	0.62-0.75	16-19	1.22	31	2.40	61	1.71	43
2.9 ^a	74 ^a	9	1.12-1.21	28-31	1.51	38	3.32	84	2.17	55
3.9	99	12	1.62-1.68	41-43	1.86	47	4.26	108	2.64	67
5.1	130	16	2.26-2.31	57-59	2.11	54	5.53	140	3.28	83
6.4	163	20	2.91-2.95	74-75	2.31	59	6.79	172	3.91	99
SERIES 2400 RADIUS FRICTION TOP - WITH OR WITHOUT HOLD DOWN GUIDES										
2.0 ^a	51 ^a	6	0.62-0.75	16-19	1.22	31	2.20	56	1.51	38
2.9 ^a	74 ^a	9	1.12-1.21	28-31	1.51	38	3.12	79	1.97	50
3.9	99	12	1.62-1.68	41-43	1.86	47	4.06	103	2.44	62
5.1	130	16	2.26-2.31	57-59	2.11	54	5.33	135	3.08	78
6.4	163	20	2.91-2.95	74-75	2.31	59	6.59	167	3.71	94
SERIES 2400 RADIUS WITH INSERT ROLLERS (ALL STYLES) - FREE FLOATING ROLLERS										
2.0 ^a	51 ^a	6	0.62-0.75	16-19	1.22	31	2.09	53	1.40	36
2.9 ^a	74 ^a	9	1.12-1.21	28-31	1.53	39	3.01	76	1.86	47
3.9	99	12	1.62-1.68	41-43	1.78	45	3.95	100	2.33	59
5.1	130	16	2.26-2.31	57-59	2.06	52	5.21	132	2.96	75
6.4	163	20	2.91-2.95	74-75	2.31	59	6.48	165	3.60	91
SERIES 2400 RADIUS WITH INSERT ROLLERS (ALL STYLES) - DRIVEN ROLLERS										
2.0 ^a	51 ^a	6	0.53-0.66	13-17	1.24	31	2.09	53	1.40	36
2.9 ^a	74 ^a	9	1.04-1.12	26-31	1.57	40	3.01	76	1.86	47

Sprocket Description		A		B		C		E		
Pitch Diameter		No. Teeth	Range (Bottom to Top)		in.	mm	in.	mm	in.	mm
in.	mm		in.	mm						
3.9	99	12	1.53-1.59	39-40	1.92	49	3.95	100	2.33	59
5.1	130	16	2.18-2.23	55-57	2.19	56	5.21	132	2.96	75
6.4	163	20	2.82-2.86	72-73	2.41	61	6.48	165	3.60	91
SERIES 2400 RADIUS RAISED RIB										
2.0	51	6	0.62-0.75	16-19	1.22	31	2.50	64	1.81	46
2.9	74	9	1.12-1.21	28-31	1.51	38	3.42	87	2.27	58
3.9	99	12	1.62-1.68	41-43	1.86	47	4.36	111	2.74	70
5.1	130	16	2.26-2.31	57-59	2.11	54	5.63	143	3.38	86
6.4	163	20	2.91-2.95	74-75	2.31	59	6.89	175	4.01	102
SERIES 2400 RADIUS FLAT TOP										
2.0	51	6	0.62-0.75	16-19	1.22	31	2.15	55	1.46	37
2.9	74	9	1.12-1.21	28-31	1.51	38	3.07	78	1.92	49
3.9	99	12	1.62-1.68	41-43	1.86	47	4.01	102	2.39	61
5.1	130	16	2.26-2.31	57-59	2.11	54	5.28	134	3.03	77
6.4	163	20	2.91-2.95	74-75	2.31	59	6.54	166	3.66	93

a. Cannot be used with Hold Down Guides.

Dead Plate Gap

Where there is a transfer point from a belt without finger transfer plates to a dead plate, there should be a gap between the surfaces to allow for the chordal action of the belt. As the belt engages its sprockets, chordal action causes the modules to move past a *fixed* point (the tip of the dead plate) with *varying* clearances. The table below shows the minimum amount of gap which occurs at the “low point” of the modules if the tip of the dead plate just comes in contact with the “high point” as the modules pass.

In some installations it may be desirable to keep the tip of the dead plate in contact with the belt, rather than allow a gap to occur. This can be done by hinging the mounting bracket for the dead plate. This allows the dead plate to move as the modules pass, but results in a small oscillating motion which may present tippage problems for sensitive containers or products.

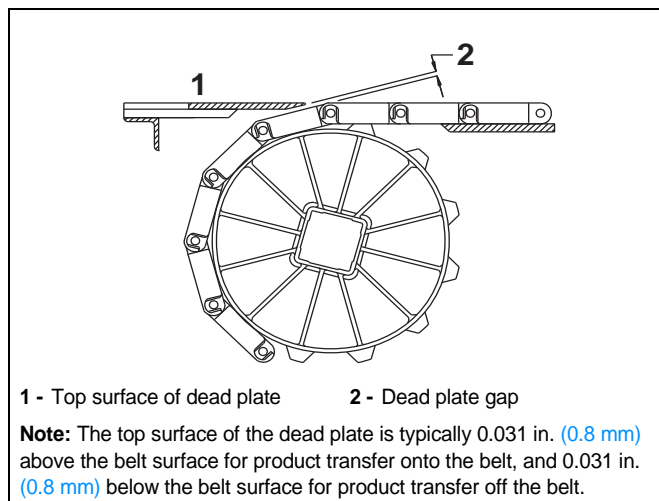

Sprocket Description			Gap	
Pitch Diameter		No. Teeth	in.	mm
in.	mm			
2.0	51	6	0.134	3.4
2.9	74	9	0.088	2.2
3.9	99	12	0.065	1.7
5.1	130	16	0.050	1.3
6.4	163	20	0.039	1.0

HOLD DOWN RAILS AND WEARSTRIPS

Intralox recommends using continuous hold down rails through an entire turn, starting at a distance of 1X the belt width before the turn and ending 1X the belt width after the turn. This applies to both carryway and returnway. The use of

hold down rails along both side of the belt over the full carryway is recommended but not mandatory.

The hold down guide design allows the belt to be held down without the wearstrip interfering with the carryway surface (for design guidelines regarding Series 2400 with hold down guides, contact Technical Support Group). See “*Custom wearstrips*” (page 416).

STANDARD BELTS

FLUSH EDGE WITH WEARSTRIP

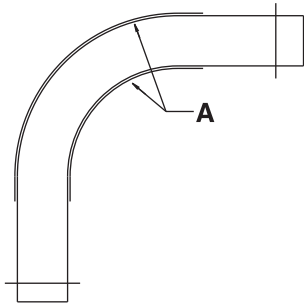

- A - HOLD DOWN RAIL PLACEMENT
- B - OUTSIDE HOLD DOWN RAIL

CROSS SECTION VIEW THROUGH CURVE

CARRYWAY DESIGN

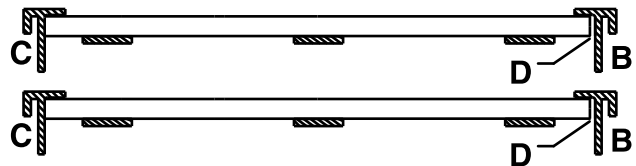

RETURNWAY DESIGN

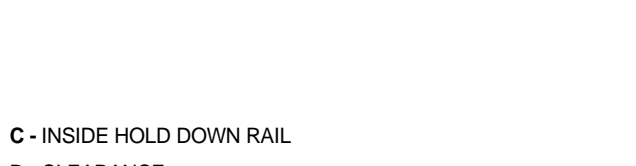

- C - INSIDE HOLD DOWN RAIL
- D - CLEARANCE

Fig. 2-4 HOLD DOWN RAILS AND WEARSTRIPS FOR SERIES 2400 FLAT-TURNS - STANDARD BELTS

HIGH DECK AND RAISED RIB BELTS

FLUSH EDGE WITH WEARSTRIP

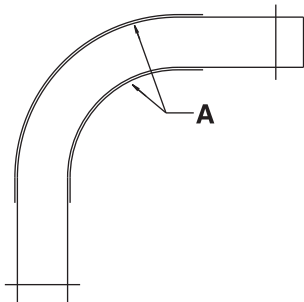

- A - HOLD DOWN RAIL PLACEMENT
- B - OUTSIDE HOLD DOWN RAIL
- C - INSIDE HOLD DOWN RAIL

CROSS SECTION VIEW THROUGH CURVE

CARRYWAY DESIGN

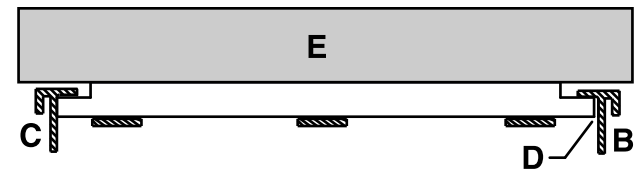

RETURNWAY DESIGN

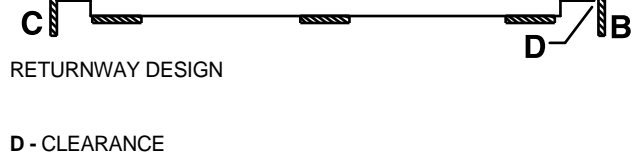

- D - CLEARANCE
- E - PRODUCT

Fig. 2-5 HOLD DOWN RAILS AND WEARSTRIPS FOR SERIES 2400 FLAT-TURNS - HIGH DECK AND RAISED RIB BELTS

BELTS WITH HOLD DOWN GUIDES

Special wearstrip guidelines for lightly loaded belts with Hold Down Guides.

CROSS SECTION VIEW THROUGH CURVE - WITH INNER BUMP RAIL

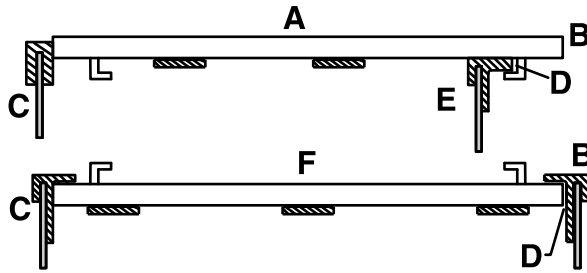

A - CARRYWAY DESIGN

B - OUTSIDE EDGE

C - INSIDE EDGE

WARNING -Hold down Guides should never be used to guide the belt through the turn in heavily loaded or high-speed applications. Rapid wear to the Hold Down Guides and/or wearstrip will occur in applications with high loads or speeds. Hold Down Guides should never be used to hold the belt down through a negative transition. Contact Intralox Customer Service for a belt pull analysis.

CROSS SECTION VIEW THROUGH CURVE - NO BUMP RAIL

Requirements: Maximum belt pull <20% allowable; belt speed <50 FPM

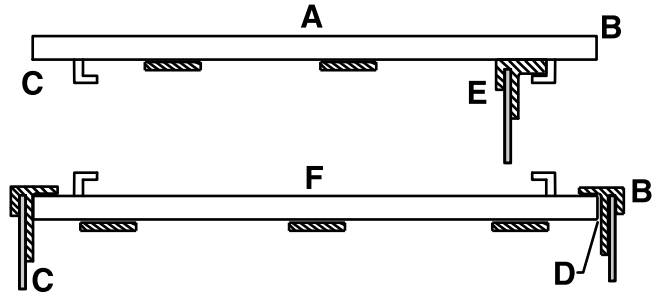

D - CLEARANCE

E - HOLD DOWN GUIDE WEARSTRIP

F - RETURNWAY DESIGN

Fig. 2-6 HOLD DOWN RAILS AND WEARSTRIPS FOR SERIES 2400 FLAT-TURNS - BELTS WITH HOLD DOWN GUIDES

BELT SELECTION INSTRUCTIONS

ENGINEERING PROGRAM ANALYSIS FOR SERIES 2400

Intralox Customer Service Technical Support Group can calculate the estimated belt pull for radius applications using **Series 2400**. The following information is required (refer to "Radius belt data sheet" (page 469)):

- Any environmental conditions which may affect the friction coefficient (for dirty or abrasive conditions, use higher friction coefficients than normal)
- Belt width
- Length of each straight run
- Turning angle of each turn

- Turn direction of each turn
- Inside turning radius of each turn
- Carryway/hold down rail material
- Product loading lb/ft² (kg/m²)
- Product back-up conditions
- Belt speed
- Elevation changes on each section
- Operating temperatures.

For assistance with radius belt and low-tension capstan drive spiral selections, contact Intralox Customer Service Technical Support Group. The Engineering Program should be run to ensure that the belt is strong enough for the radius application in question.

SERIES 2400 DESIGN GUIDE SUMMARY

For more information, see the **Installation, Maintenance and Troubleshooting manual** available from Intralox.

- A** - The minimum turning radius for **Series 2400** is 2.2 times the belt width, measured from the inside edge for the standard edge or 1.7 times the belt width for the tight turning style.
- B** - The minimum straight run required between turns of opposing direction is 2.0 times the belt width. Shorter straight sections will lead to high wear on the edge guide rail and high pull stresses in the belt.
- C** - There is no minimum straight run required between turns that are in the same direction.
- D** - The minimum final straight run (leading to the drive shaft) should be a minimum of 5 ft. (1.5 m). If 5 ft. (1.5 m) is not feasible, then a shorter distance (down to 1.5 times the belt width) would require a weighted take up in order to avoid sprocket wear and tracking problems. See "Special Take-Up Arrangements" (page 431).

- E** - The minimum length of the first straight run (immediately after the idle shaft) is 1.5 times the belt width. When shorter lengths are required (down to 1.0 times the width), an idle roller may be used in place of sprockets.
- F** - IDLE SHAFT
- G** - 1ST TURN
- H** - BELT WIDTH
- I** - BELT TRAVEL
- J** - 2ND TURN
- K** - DRIVE MOTOR
- L** - DRIVE SHAFT

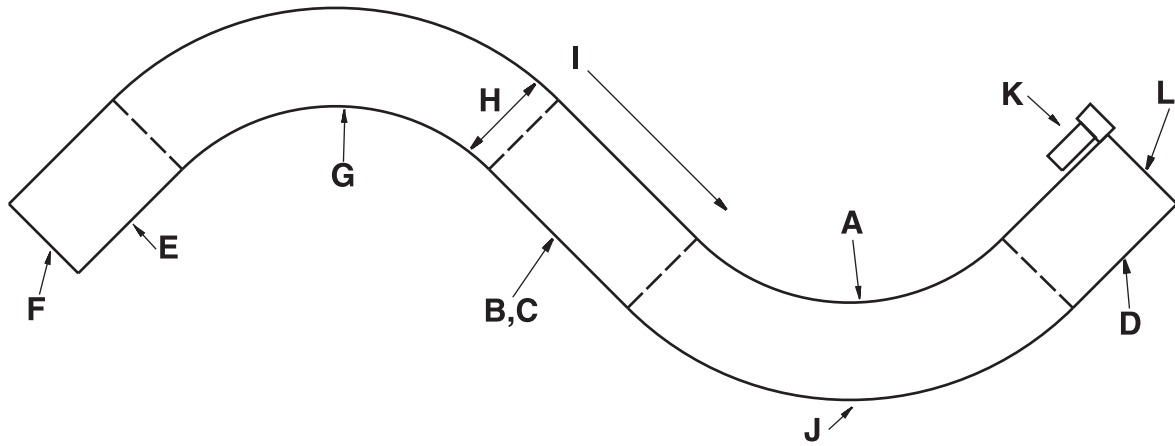
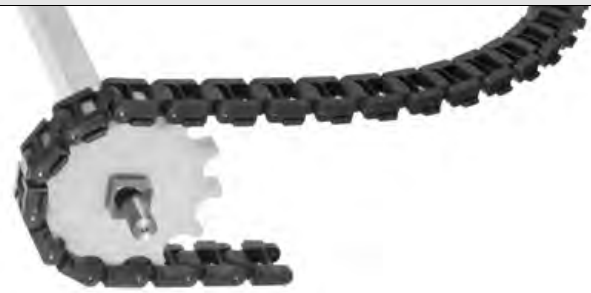

Fig. 2-7 TYPICAL 2-TURN RADIUS LAYOUT

Knuckle Chain

	in	mm
Pitch	2.00	50.8
Molded Width	2.25	57
Open Area	-	
Hinge Style	Closed	
Drive Method	Center-driven	



Product Notes

- **Contact Intralox for precise belt measurements and stock status before designing equipment or ordering a belt.**
- Thick, durable plastic surface around stainless steel pins for long life and less breakage.
- Available in both straight and turning versions.
- Turning version designed for applications with a minimum centerline turn radius of 16 in (406 mm).
- Both versions are available with extended pins.
- Available in 10 ft. (3.1 m) boxed lengths.
- Capable of running on the same tracks as other common chains.

WARNING: Only the Series 3000T (turning version) Knuckle Chain can be used for turning applications. The Series 3000S (straight version) Knuckle Chain cannot be used for turning applications. Hold down wearstrips are mandatory on the inside and outside edges of all turns, on both the carrying and return sides of the belt. Unless they interfere with the operation of the carrying equipment, the hold down wearstrips should be used throughout the conveyor to protect both the belt and personnel next to the conveyor.

Additional Information

- See "Belt Selection Process" (page 5)
- See "Standard Belt Materials" (page 9)
- See "Special Application Belt Materials" (page 9)
- See "Friction Factors" (page 13)

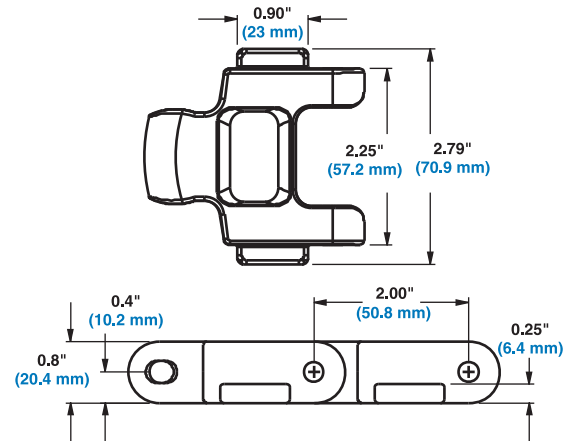

Series 3000T shown

Belt Data

Chain Material	Standard Rod Material Ø 0.25 in (6.4 mm)	BS Chain Strength		Temperature Range (continuous)		W Chain Weight	
		lb	kg	°F	°C	lb/ft	kg/m
Acetal (Straight)	303 SS	700	317	-50 to 200	-46 to 93	0.88	1.21
Acetal (Turning)	303 SS	560	254	-50 to 200	-46 to 93	0.90	1.25

Mesh Top

	in	mm
Pitch	2.00	50.8
Minimum Width	2.3	57.2
Opening Sizes (approx.)	-	-
Hinge Style	Closed	
Drive Method	Center-Driven	

Product Notes

- **Contact Intralox for precise belt measurements and stock status before designing equipment or ordering a belt.**
- Thick, durable plastic surface around stainless steel pins for long life and less breakage.
- Mesh top design eliminates open area for improved worker safety.
- Improved design for cleaning.
- Available in both straight and turning versions.
- Both versions are available with extended pins.
- Available in 10 ft (3.1 m) boxed lengths.
- Mesh top design is capable of running on the same tracks as other common chains.
- Turning version designed for applications with a minimum centerline turn radius of 16 in (406 mm).
- **WARNING:** Only the Series 3000T (turning version) Mesh Top Chain can be used for turning applications. The Series 3000S (straight version) Mesh Top Chain cannot be used for turning applications. Hold down wearstrips are mandatory on the inside and outside edges of all turns, on both the carrying and return side of the belt. Unless they interfere with the operation of the carrying equipment, the hold down wearstrips should be used throughout the conveyor to protect the belt and personnel next to the conveyor.

Additional Information

- See "Belt Selection Process" (page 5)
- See "Standard Belt Materials" (page 9)
- See "Special Application Belt Materials" (page 9)
- See "Friction Factors" (page 13)

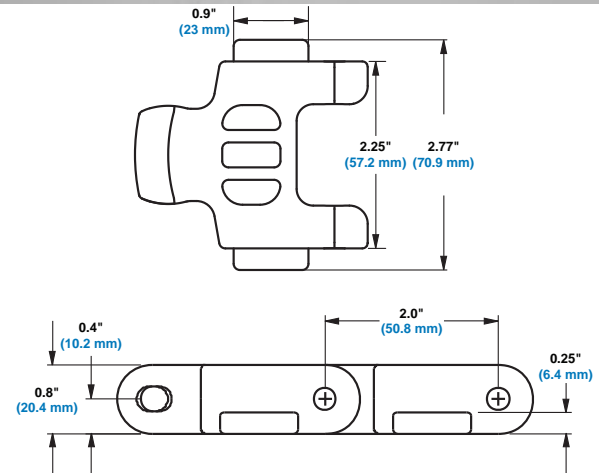
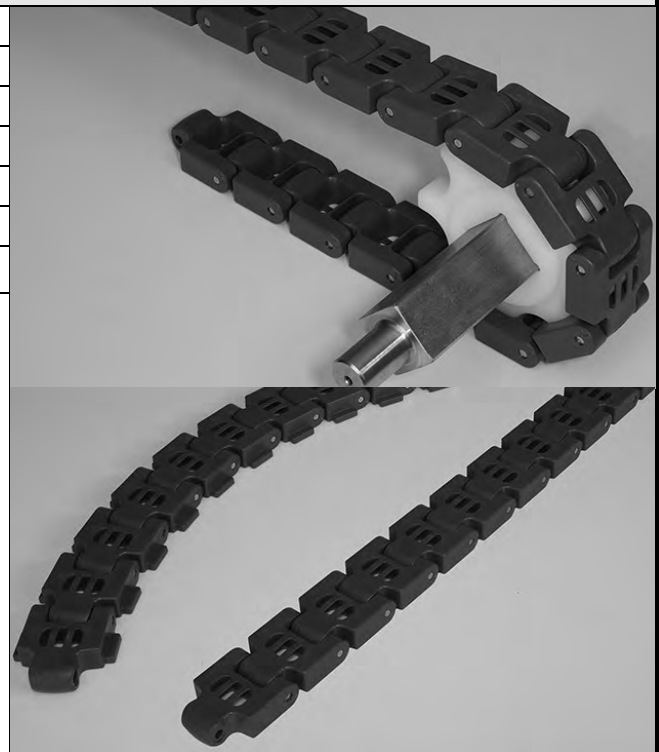

Belt Data

Chain Material	Standard Rod Material Ø 0.25 in (6.4 mm)	BS Chain Strength		Temperature Range (continuous)		W Chain Weight	
		lb	kg	°F	°C	lb./ft. ²	kg/m ²
Acetal (Straight)	303 SS	700	318	-50 to 200	-46 to 93	0.89	1.32
Acetal (Turning)	303 SS	560	254	-50 to 200	-46 to 93	0.91	1.36

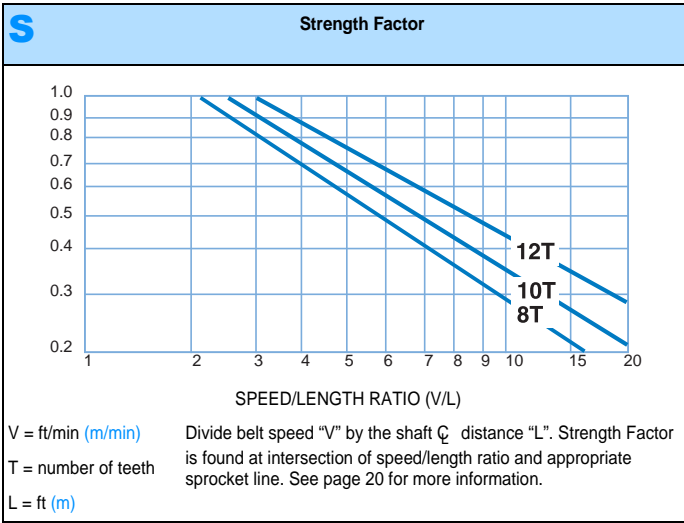

Chain Pull Limit with UHMW Polyethylene Sprockets, Based on Bore Size - lb (kg)

No. of Teeth	Nom. Pitch Diameter		1.5 in square		40 mm square		1 in round		1.25 in round		1.5 in round	
	in	mm	lb	kg	lb	kg	lb	kg	lb	kg	lb	kg
8	5.2	132	640	290	640	290	74	34	90	41	162	74
10	6.5	165	520	236	520	236	78	35	95	43	172	78
12	7.7	196	432	196	432	196	65	29	79	36	143	65

Bold entries indicate standard sizes

UHMW Polyethylene Sprocket^a

No. of Teeth (Chordal Action)	Nom. Pitch Dia. in	Nom. Pitch Dia. mm	Nom. Outer Dia. in	Nom. Outer Dia. mm	Nom. Hub Width in	Nom. Hub Width mm	Available Bore Sizes			
							U.S. Sizes		Metric Sizes	
							Round in ^b	Square in	Round mm ^b	Square mm
8 (7.61%) <i>Square Bore</i>	5.2	132	5.3	135	1.5	38	1-1/4	1.5		40
8 (7.61%) <i>Round Bore</i>	5.2	132	5.3	135	1.2	30	1-1/4	1.5		40
10 (4.89%)	6.5	165	6.7	170	1.5	38	1-1/4	1.5		40
12 (3.41%)	7.7	196	8.0	203	1.5	38	1-1/4	1.5		40

a. **Contact Customer Service for lead times.**
 b. Imperial key sizes on round bore sprockets conform to ANSI standard B17.1-1967 (R1989) and metric key sizes conform to DIN standard 6885.

Extended Pins and Tabs

EXTENDED PINS — Modules with 303 stainless steel extended pins can be spliced into both the basic turning and straight running chains. These pins are commonly used in side by side chain strands where rollers are used for low back pressure applications. The minimum extended pin spacing is 2.0 in (50.8 mm). The extended pin modules can be spliced into the standard chain every 2.0 in (50.8 mm).

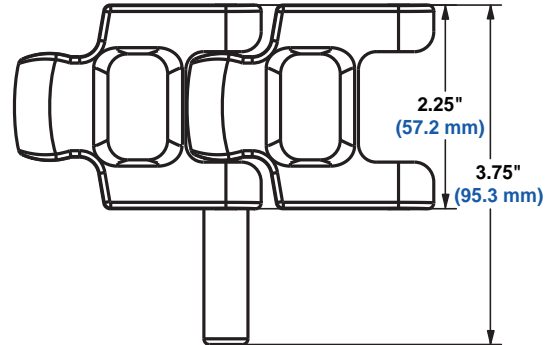

Extended pins for straight or turning versions

EXTENDED TABS — Modules with extended tabs can be spliced into both the basic turning and straight running chains. These extended tabs can be used to attach flights, cleats, etc. The extended tab modules are based on the turning chain design, so the rating for the turning chain should be used even if the extended tab modules are spliced into straight running chain. The minimum tab spacing is 2.0 in (50.8 mm). The tabs can be spliced into the standard chain every 2.0 in (50.8 mm).

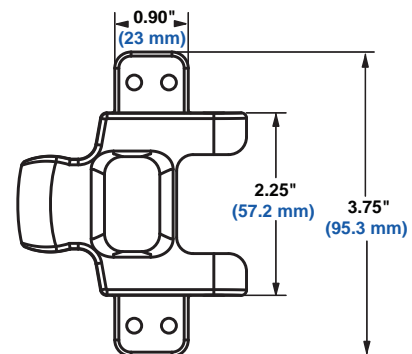

Extended tabs for straight or turning versions

Intralox offers only extended tabs and extended pins. Attachments for either of these accessories are not available through Intralox. Contact Customer Service for lead times.

Conveyor Frame Dimensions

Regardless of type or configuration, all conveyors using Intralox belts have some basic dimensional requirements. Specifically, dimensions "A", "B", "C" and "E" listed below should be implemented in any design.

For general applications and applications where end transfer of tip-sensitive product is not critical, use the "A" dimension at the bottom of the range.

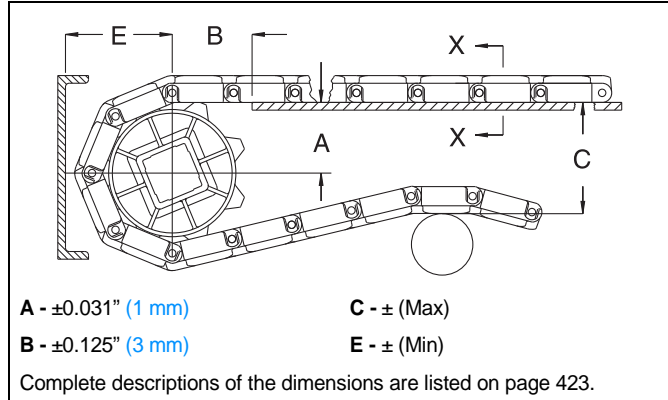

Sprocket Description			A		B		C		E	
Pitch Diameter		No. Teeth	Range (Bottom to Top)		in.	mm	in.	mm	in.	mm
in.	mm		in.	mm						
SERIES 3000 KNUCKLE CHAIN, MESH TOP										
5.2	132	8	2.01-2.21	51-56	2.29	58	5.23	1.33	3.14	80
6.5	165	10	2.68-2.84	68-72	2.63	67	6.47	164	3.76	96
7.7	196	12	3.33-3.46	85-88	2.94	75	7.73	196	4.39	112

Dead Plate Gap

Where there is a transfer point from a belt without finger transfer plates to a dead plate, there should be a gap between the surfaces to allow for the chordal action of the belt. As the belt engages its sprockets, chordal action causes the modules to move past a *fixed* point (the tip of the dead plate) with *varying* clearances. The table below shows the minimum amount of gap which occurs at the "low point" of the modules if the tip of the dead plate just comes in contact with the "high point" as the modules pass.

In some installations it may be desirable to keep the tip of the dead plate in contact with the belt, rather than allow a gap to occur. This can be done by hinging the mounting bracket for the dead plate. This allows the dead plate to move as the modules pass, but results in a small oscillating motion which may present tippage problems for sensitive containers or products.

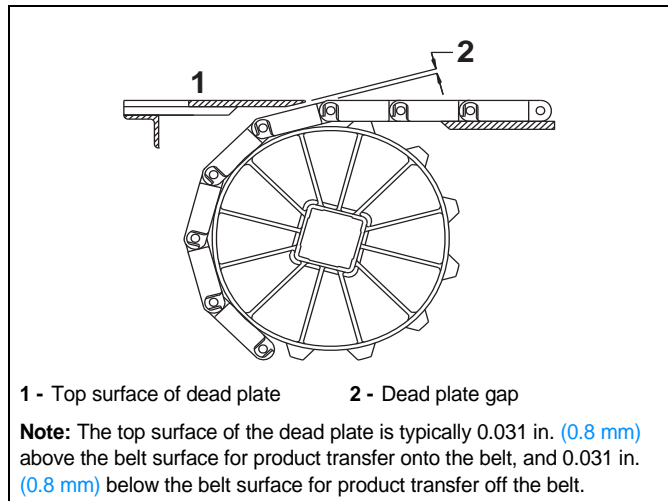

Sprocket Description			Gap	
Pitch Diameter		No. Teeth	in.	mm
in.	mm			
5.2	132	8	0.200	5.1
6.5	165	10	0.158	4.0
7.7	196	12	0.132	3.4

S4009 Flush Grid

	in	mm
Pitch	1.00	25.4
Molded Width	3.3	84
Open Area	13%	
Hinge Style	Closed	
Drive Method	Hinge-driven	



Product Notes

- **Contact Intralox for precise belt measurements and stock status before designing equipment or ordering a belt.**
- Designed for applications with a minimum centerline turn radius of 18 in (457 mm).
- Same deck thickness as the straight running belt counterpart Series 900 FG [0.344 in (8.7 mm)].
- Series 4000 belts use S1400 sprockets.
- All Series 1400/4000 sprockets use the split design so shafts do not have to be removed for retrofits and changeovers.
- Available in 10 ft. (3.1 m) boxed lengths.
- Corner Tracks, with bevel design, are mandatory on the inside edges of all turns.
- Intralox's Engineering Program for S4000 belts can calculate the estimated belt pull for your system. Contact Intralox Customer Service for more information.

Additional Information

- See "Belt Selection Process" (page 5)
- See "Standard Belt Materials" (page 9)
- See "Special Application Belt Materials" (page 9)
- See "Friction Factors" (page 13)

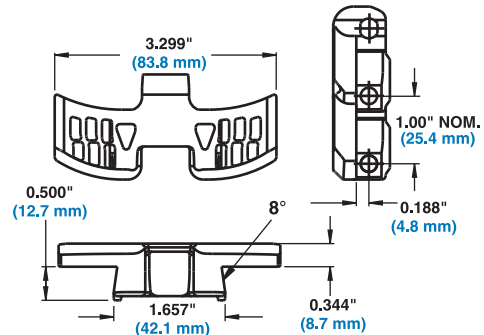

Belt Data

Belt Material	Belt Width		Standard Rod Material Ø 0.25 in (6.4 mm)	BS Belt Strength	Temperature Range (continuous)		W Belt Weight		
	in	mm			°F	°C		lb/ft	kg/m
Acetal	3.3	84	303 SS	500	227	-50 to 200	-46 to 93	0.97	1.44
HHR Nylon	3.3	84	303 SS	500	227	-50 to 310	-46 to 154	0.97	1.44

S4009 Flat Top

	in	mm
Pitch	1.00	25.4
Molded Width	3.3	84
Open Area	0%	
Hinge Style	Closed	
Drive Method	Hinge-driven	



Product Notes

- **Contact Intralox for precise belt measurements and stock status before designing equipment or ordering a belt.**
- Designed for applications with a minimum centerline turn radius of 18 in (457 mm).
- Same deck thickness as the straight running belt counterpart Series 900 FT [0.384 in (9.8 mm)].
- Series 4000 belts use S1400 sprockets.
- All Series 1400/4000 sprockets use the split design so shafts do not have to be removed for retrofits and changeovers.
- Available in 10 ft. (3.1 m) boxed lengths.
- Corner Tracks, with bevel design, are mandatory on the inside edges of all turns.
- Intralox's Engineering Program for S4000 belts can calculate the estimated belt pull for your system. Contact Intralox Customer Service for more information.
- Refer to Belt Data table below for minimum centerline turn radius.



Additional Information

- See "Belt Selection Process" (page 5)
- See "Standard Belt Materials" (page 9)
- See "Special Application Belt Materials" (page 9)
- See "Friction Factors" (page 13)

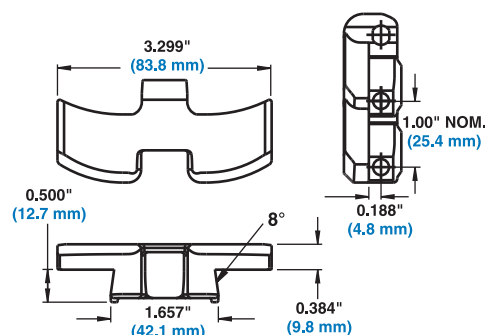

Belt Data

Belt Material	Belt Width		Standard Rod Material Ø 0.25 in (6.4 mm)	BS Belt Strength		Temperature Range (continuous)		W Belt Weight	
	in	mm		lb	kg	°F	°C	lb/ft	kg/m
Acetal	3.3	84	303 SS	500	227	-50 to 200	-46 to 93	1.11	1.65
HHR Nylon	3.3	84	303 SS	500	227	-50 to 310	-46 to 154	0.98	1.46

S4014 Flat Top

	in	mm
Pitch	1.00	25.4
Molded Width	3.3	84
Open Area	0%	
Hinge Style	Closed	
Drive Method	Hinge-driven	

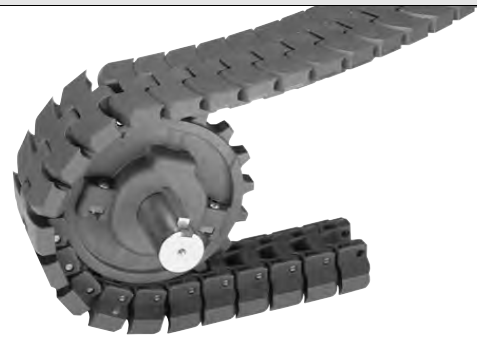

Product Notes

- **Contact Intralox for precise belt measurements and stock status before designing equipment or ordering a belt.**
- Designed for applications with a minimum centerline turn radius of 18 in (457 mm).
- Same deck thickness as the straight running belt counterpart Series 1400 FT [0.5 in (12.7 mm)].
- Series 4000 belts use S1400 sprockets.
- All Series 1400/4000 sprockets use the split design so shafts do not have to be removed for retrofits and changeovers.
- Available in 10 ft. (3.1 m) boxed lengths.
- Corner Tracks, with bevel design, are mandatory on the inside edges of all turns.
- Intralox's Engineering Program for S4000 belts can calculate the estimated belt pull for your system. Contact Intralox Customer Service for more information.

Additional Information

- See "Belt Selection Process" (page 5)
- See "Standard Belt Materials" (page 9)
- See "Special Application Belt Materials" (page 9)
- See "Friction Factors" (page 13)

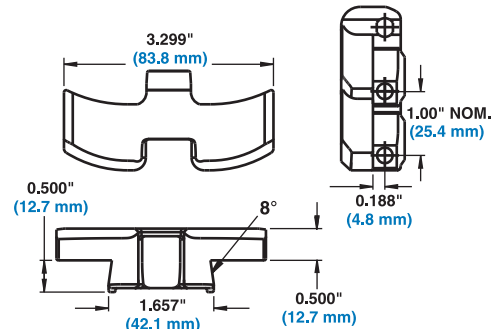

Belt Data

Belt Material	Belt Width		Standard Rod Material Ø 0.25 in (6.4 mm)	BS Belt Strength		Temperature Range (continuous)		W Belt Weight	
	in	mm		lb	kg	°F	°C	lb/ft	kg/m
Acetal	3.3	84	303 SS	500	227	-50 to 200	-46 to 93	1.29	1.92

S4030 7.5-in ProTrax Sideflexing Flat Top with Tabs

	in	mm
Pitch	1.00	25.4
Molded Width	7.5	191.0
Open Area	0%	
Hinge Style	Closed	
Drive Method	Hinge-driven	



Product Notes

- **Contact Intralox for precise belt measurements and stock status before designing equipment or ordering a belt.**
- Two powerful, blue, teflon-coated magnets embedded in each module (one magnet per wing).
- Thicker deck than S409X Flat Top for increased wear resistance.
- S4000 belts use S1400/4000 sprockets.
- Minimum sprocket pitch diameter is 3.9 in (99.0 mm).
- Standard configuration consists of magnetic modules and S403X Sideflexing Flat Top modules alternating every other row.
- Ideal for incline, decline, vertical switch, and other applications.
- Only needs one drive and idle sprocket per belt strand.
- Blue, metal detectable, nylon caps retain magnets in modules.
- Belt spacing should be determined based on maximum surface contact with the bottom surface of the conveyed product.
- Hold down tabs match dimensions of S4090.



Additional Information

- See "Belt Selection Process" (page 5)
- See "Standard Belt Materials" (page 9)
- See "Special Application Belt Materials" (page 9)
- See "Friction Factors" (page 13)

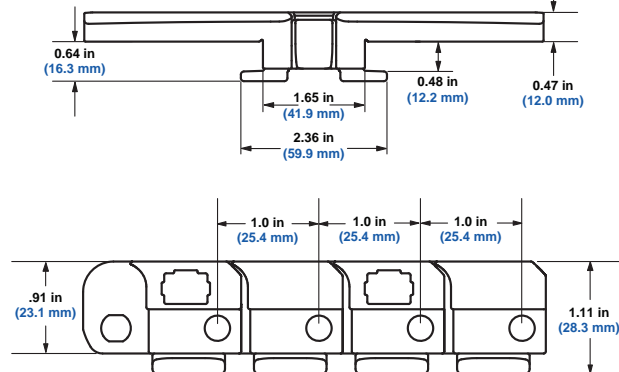

Belt Data

Belt Material	Belt Width		Standard Rod Material Ø 0.25 in (6.4 mm)	BS Belt Strength		Temperature Range (continuous)		W Belt Weight	
	in	mm		lb	kg	°F	°C	lb/ft	kg/m
HHR Nylon	7.5	191.0	303 SS	500	227	-50 to 310	-46 to 154	2.44	3.63

S4031 7.5-in ProTrax Sideflexing Flat Top with Tabs

	in	mm
Pitch	1.00	25.4
Molded Width	7.5	191.0
Open Area	0%	
Hinge Style	Closed	
Drive Method	Hinge-driven	

Product Notes

- **Contact Intralox for precise belt measurements and stock status before designing equipment or ordering a belt.**
- Two powerful, blue, teflon-coated magnets embedded in each module (one magnet per wing).
- Thicker deck than S409X Flat Top for increased wear resistance.
- S4000 belts use S1400/4000 sprockets.
- Minimum sprocket pitch diameter is 3.9 in (99.0 mm).
- Standard configuration consists of magnetic modules and S403X Sideflexing Flat Top modules alternating every other row.
- Ideal for incline, decline, vertical switch, and other applications.
- Only needs one drive and idle sprocket per belt strand.
- Blue, metal detectable, nylon caps retain magnets in modules.
- Belt spacing should be determined based on maximum surface contact with the bottom surface of the conveyed product.
- Hold down tabs match dimensions of S4091.

Additional Information

- See "Belt Selection Process" (page 5)
- See "Standard Belt Materials" (page 9)
- See "Special Application Belt Materials" (page 9)
- See "Friction Factors" (page 13)

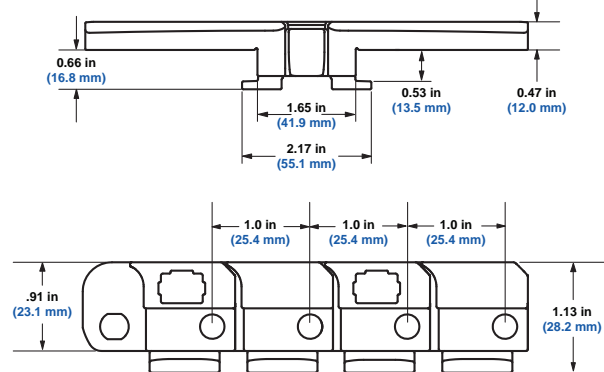

SECTION 2

4000

Belt Data

Belt Material	Belt Width		Standard Rod Material Ø 0.25 in (6.4 mm)	BS Belt Strength		Temperature Range (continuous)		W Belt Weight	
	in	mm		lb	kg	°F	°C	lb/ft	kg/m
HHR Nylon	7.5	191.0	303 SS	500	227	-50 to 310	-46 to 154	2.44	3.63

S4032 7.5-in ProTrax Sideflexing Flat Top with Tabs

	in	mm
Pitch	1.00	25.4
Molded Width	7.5	191.0
Open Area	0%	
Hinge Style	Closed	
Drive Method	Hinge-driven	



Product Notes

- Contact Intralox for precise belt measurements and stock status before designing equipment or ordering a belt.
- Two powerful, blue, teflon-coated magnets embedded in each module (one magnet per wing).
- Thicker deck than S409X Flat Top for increased wear resistance.
- S4000 belts use S1400/4000 sprockets.
- Minimum sprocket pitch diameter is 5.1 in (129.5 mm).
- Standard configuration consists of magnetic modules and S403X Sideflexing Flat Top modules alternating every other row.
- Ideal for incline, decline, vertical switch, pan indexing, metering, de-lidding, and radius applications.
- Only needs one drive and idle sprocket per belt strand.
- Blue, metal detectable, nylon caps retain magnets in modules.
- Belt spacing should be determined based on maximum surface contact with the bottom surface of the conveyed product.
- Hold down tabs match dimensions of S4092.



Additional Information

- See "Belt Selection Process" (page 5)
- See "Standard Belt Materials" (page 9)
- See "Special Application Belt Materials" (page 9)
- See "Friction Factors" (page 13)

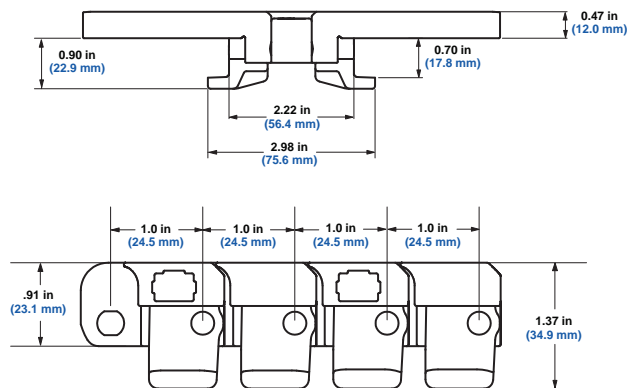

Belt Data

Belt Material	Belt Width		Standard Rod Material Ø 0.25 in (6.4 mm)	BS Belt Strength		Temperature Range (continuous)		W Belt Weight	
	in	mm		lb	kg	°F	°C	lb/ft	kg/m
HHR Nylon	7.5	191.0	303 SS	500	227	-50 to 310	-46 to 154	2.66	3.95

S4033 7.5-in ProTrax Sideflexing Flat Top

	in	mm
Pitch	1.00	25.4
Molded Width	7.5	191.0
Open Area	0%	
Hinge Style	Closed	
Drive Method	Hinge-driven	



Product Notes

- **Contact Intralox for precise belt measurements and stock status before designing equipment or ordering a belt.**
- Two powerful, blue, teflon-coated magnets embedded in each module (one magnet per wing).
- Thicker deck than S409X Flat Top for increased wear resistance.
- S4000 belts use S1400/4000 sprockets.
- Minimum sprocket pitch diameter is 3.9 in (99.0 mm).
- Standard configuration consists of magnetic modules and S403X Sideflexing Flat Top modules alternating every other row.
- Ideal for incline, decline, vertical switch, and other applications.
- Only needs one drive and idle sprocket per belt strand.
- Blue, metal detectable, nylon caps retain magnets in modules.
- Belt spacing should be determined based on maximum surface contact with the bottom surface of the conveyed product.

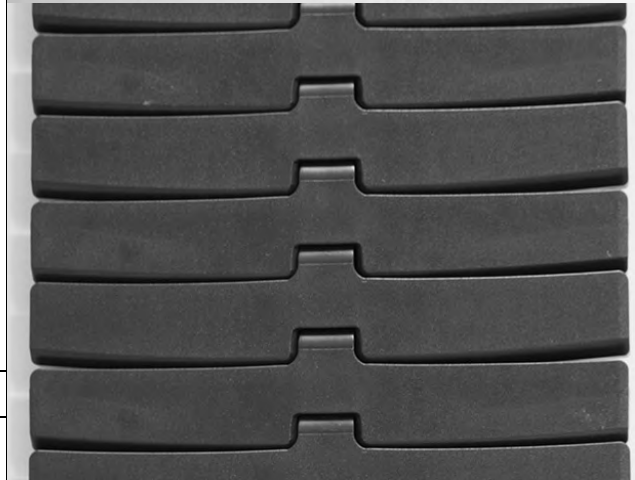

Additional Information

- See "Belt Selection Process" (page 5)
- See "Standard Belt Materials" (page 9)
- See "Special Application Belt Materials" (page 9)
- See "Friction Factors" (page 13)

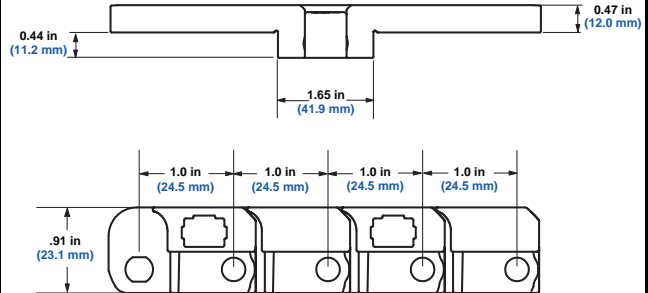

SECTION 2

4000

Belt Data

Belt Material	Belt Width		Standard Rod Material Ø 0.25 in (6.4 mm)	BS Belt Strength		Temperature Range (continuous)		W Belt Weight	
	in	mm		lb	kg	°F	°C	lb/ft	kg/m
HHR Nylon	7.5	191.0	303 SS	500	227	-50 to 310	-46 to 154	2.29	3.41

S4090 Sideflexing Flat Top

	in	mm
Pitch	1.00	25.4
Molded Width	3.25	83
	4.5	114
	7.5	191
Open Area	0%	
Hinge Style	Closed	
Drive Method	Hinge-driven	

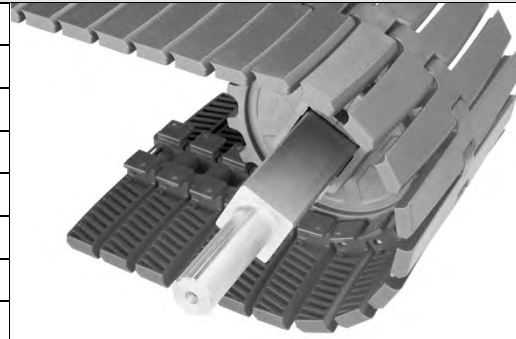

Product Notes

- **Contact Intralox for precise belt measurements and stock status before designing equipment or ordering a belt.**
- Same deck thickness as the straight running belt counterpart Series 900 Flat Top [0.384 in (9.8 mm)].
- Series 4000 belts use S1400 sprockets.
- All Series 1400/4000 sprockets use the split design so shafts do not have to be removed for retrofits and changeovers.
- Available in 10 ft. (3.1 m) boxed lengths.
- Intralox's Engineering Program for S4000 belts can calculate the estimated belt pull for your system. Contact Intralox Customer Service for more information.
- Refer to Belt Data table below for minimum centerline turn radius.



Additional Information

- See "Belt Selection Process" (page 5)
- See "Standard Belt Materials" (page 9)
- See "Special Application Belt Materials" (page 9)
- See "Friction Factors" (page 13)

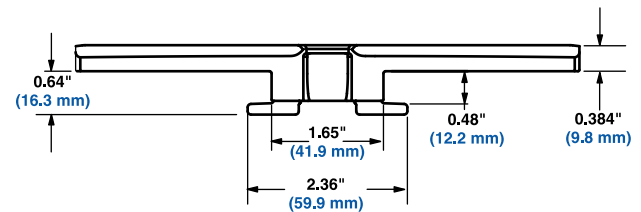

Belt Data

Belt Material	Belt Width		Standard Pin Material Ø 0.25 in (6.4 mm)	BS Belt Strength		Temperature Range (continuous)		W Belt Weight		Minimum Centerline Turn Radius	
	in	mm		lb	kg	°F	°C	lb/ft	kg/m	in	mm
Acetal	3.25	83	303 SS	500	227	-50 to 200	-46 to 93	1.21	1.80	18	457
Acetal	4.5	114	303 SS	500	227	-50 to 200	-46 to 93	1.40	2.08	18	457
Acetal	7.5	191	303 SS	500	227	-50 to 200	-46 to 93	1.86	2.77	24	610
HR Nylon ^a	3.25	83	303 SS	500	227	-50 to 240	-46 to 116	1.02	1.52	18	457
HR Nylon ^a	7.5	191	303 SS	500	227	-50 to 240	-46 to 116	1.54	2.29	24	610
HHR Nylon	3.25	83	303 SS	500	227	-50 to 310	-46 to 154	1.04	1.55	18	457
HHR Nylon	4.5	114	303 SS	500	227	-50 to 310	-46 to 154	1.18	1.76	18	457
HHR Nylon	7.5	191	303 SS	500	227	-50 to 310	-46 to 154	1.57	2.34	24	610

a. This product may not be used for food contact articles that will come in contact with food containing alcohol.

S4091 Sideflexing Flat Top

	in	mm
Pitch	1.00	25.4
Molded Width	3.25	83
	4.5	114
	7.5	191
Open Area	0%	
Hinge Style	Closed	
Drive Method	Hinge-driven	

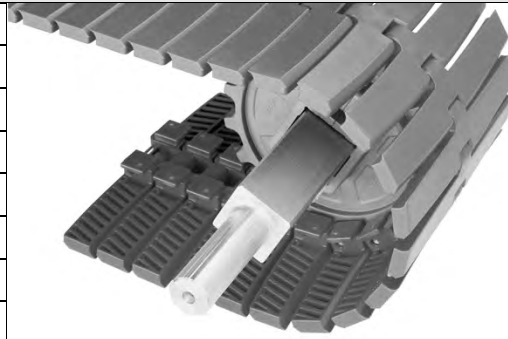

Product Notes

- **Contact Intralox for precise belt measurements and stock status before designing equipment or ordering a belt.**
- Same deck thickness as the straight running belt counterpart Series 900 Flat Top [0.384 in (9.8 mm)].
- Series 4000 belts use S1400 sprockets.
- All Series 1400/4000 sprockets use the split design so shafts do not have to be removed for retrofits and changeovers.
- Available in 10 ft. (3.1 m) boxed lengths.
- Intralox's Engineering Program for S4000 belts can calculate the estimated belt pull for your system. Contact Intralox Customer Service for more information.
- Refer to Belt Data table below for minimum centerline turn radius.



Additional Information

- See "Belt Selection Process" (page 5)
- See "Standard Belt Materials" (page 9)
- See "Special Application Belt Materials" (page 9)
- See "Friction Factors" (page 13)

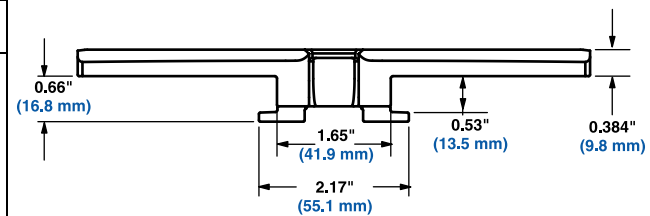

Belt Data

Belt Material	Belt Width		Standard Pin Material Ø 0.25 in (6.4 mm)	BS Belt Strength		Temperature Range (continuous)		W Belt Weight		Minimum Centerline Turn Radius	
	in	mm		lb	kg	°F	°C	lb/ft	kg/m	in	mm
Acetal	3.25	83	303 SS	500	227	-50 to 200	-46 to 93	1.22	1.81	18	457
Acetal	4.5	114	303 SS	500	227	-50 to 200	-46 to 93	1.40	2.08	18	457
Acetal	7.5	191	303 SS	500	227	-50 to 200	-46 to 93	1.84	2.74	24	610
HR Nylon ^a	3.25	83	303 SS	500	227	-50 to 240	-46 to 116	1.02	1.52	18	457
HR Nylon ^a	7.5	191	303 SS	500	227	-50 to 240	-46 to 116	1.54	2.29	24	610
HHR Nylon	3.25	83	303 SS	500	227	-50 to 240	-46 to 116	1.04	1.55	18	457
HHR Nylon	4.5	114	303 SS	500	227	-50 to 310	-46 to 154	1.18	1.76	18	457
HHR Nylon	7.5	191	303 SS	500	227	-50 to 310	-46 to 154	1.57	2.34	24	610

a. This product may not be used for food contact articles that will come in contact with food containing alcohol.

S4092 Sideflexing Flat Top

	in	mm
Pitch	1.00	25.4
Molded Width	3.25	83
	4.5	114
	7.5	191
Open Area	0%	
Hinge Style	Closed	
Drive Method	Hinge-driven	

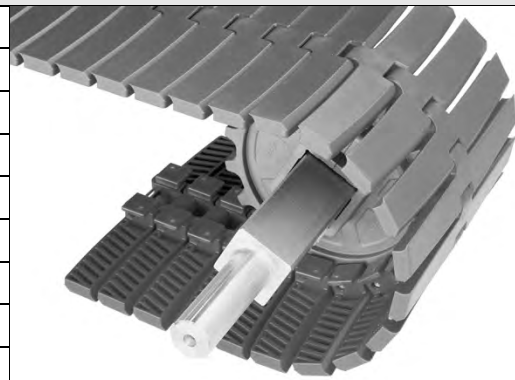

Product Notes

- **Always check with Customer Service for precise belt measurements and stock status before designing a conveyor or ordering a belt.**
- Same deck thickness as the straight running belt counterpart S900 Flat Top [0.384 in (9.8 mm)].
- S4000 belts use S1400/4000 sprockets.
- All S1400/4000 sprockets use the split design so shafts do not have to be removed for retrofits and changeovers.
- 3.9 in (99 mm) pitch diameter sprockets are not compatible with S4092 belts.
- Available in 10 ft. (3.1 m) boxed lengths.
- Intralox's Engineering Program for S4000 belts can calculate the estimated belt pull for your system. Contact Intralox Sales Engineering for assistance.
- Refer to Belt Data table below for minimum centerline turning radius.

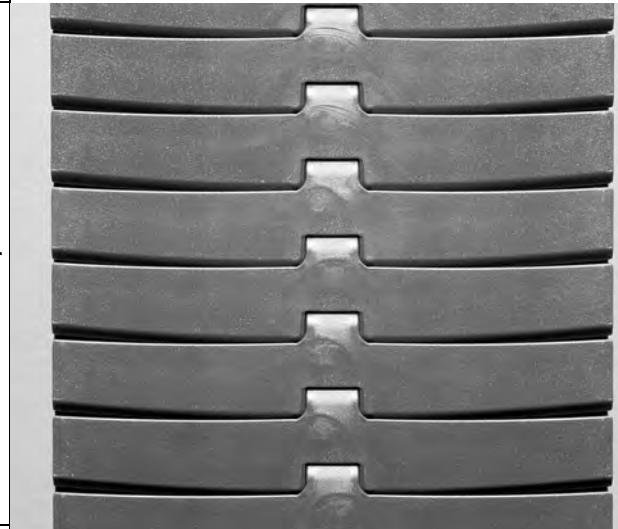

Additional Information

- See "Belt Selection Process" (page 5)
- See "Standard Belt Materials" (page 9)
- See "Special Application Belt Materials" (page 9)
- See "Friction Factors" (page 13)

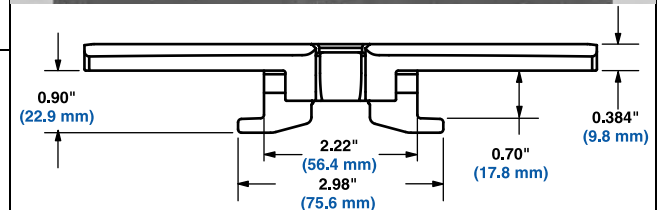

Belt Data

Belt Material	Belt Width		Standard Pin Material Ø 0.25 in (6.4 mm)	BS Belt Strength		Temperature Range (continuous)		W Belt Weight		Minimum Centerline Turning Radius		Agency Acceptability: 1=White, 2=Blue, 3=Natural, 4=Grey		
	in	mm		lb	kg	°F	°C	lb/ft	kg/m	in	mm	FDA (USA)	J ^a	EU MC ^b
Acetal	3.25	83	303 SS	500	227	-50 to 200	-46 to 93	1.43	2.13	18	457	•	•	•
Acetal	4.5	114	303 SS	500	227	-50 to 200	-46 to 93	1.61	2.40	18	457	•	•	•
Acetal	7.5	191	303 SS	500	227	-50 to 200	-46 to 93	2.05	3.05	24	610	•	•	•
HR Nylon ^c	3.25	83	303 SS	500	227	-50 to 240	-46 to 116	1.26	1.87	18	457	•		•
HR Nylon ^a	7.5	191	303 SS	500	227	-50 to 240	-46 to 116	1.71	2.55	24	610	•		•
HHR Nylon	3.25	83	303 SS	500	227	-50 to 310	-46 to 154	1.28	1.92	18	457	•		•
HHR Nylon	4.5	114	303 SS	500	227	-50 to 310	-46 to 154	1.40	2.08	18	457	•		•
HHR Nylon	7.5	191	303 SS	500	227	-50 to 310	-46 to 154	1.80	2.68	24	610	•		•

a. Japan Ministry of Health, Labour, and Welfare

b. European Migration Certificate providing approval for food contact according to EU Regulation 10/2011.

c. This product may not be used for food contact articles that will come in contact with food containing alcohol.

S4092 Sideflexing Square Friction Top

	in	mm
Pitch	1.00	25.4
Molded Width	7.5	191
Open Area	0%	
Hinge Style	Closed	
Drive Method	Hinge-driven	



Product Notes

- Always check with Customer Service for precise belt measurements and stock status before designing a conveyor or ordering a belt.
- S4000 belts use S1400/4000 sprockets.
- All S1400/4000 sprockets use the split design so shafts do not have to be removed for retrofits and changeovers.
- 3.9 in (99 mm) pitch diameter sprockets are not compatible with S4092 belts.
- Available in blue acetal with black rubber.
- Available in 10 ft. (3.1 m) boxed lengths.
- Intralox's Engineering Program for S4000 belts can calculate the estimated belt pull for your system. Contact Intralox Sales Engineering for assistance.



Additional Information

- See "Belt Selection Process" (page 5)
- See "Standard Belt Materials" (page 9)
- See "Special Application Belt Materials" (page 9)
- See "Friction Factors" (page 13)

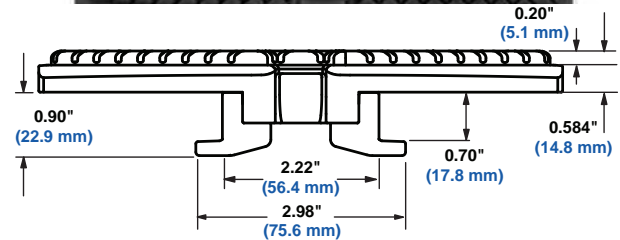

SECTION 2

4000

Belt Data

Base Belt Material	Belt Width		Base/Friction Color	Standard Rod Material Ø 0.25 in (6.4 mm)	BS Belt Strength		Temperature Range (continuous)		W Belt Weight		Friction Top Hardness	Minimum Centerline Turning Radius		Agency Acceptability	
	in	mm			lb	kg	°F	°C	lb/ft	kg/m		in	mm	FDA (USA)	EU MC ^b
Acetal	7.5	191	Blue/Black	303 SS	500	227	-10 to 130	-23 to 54	2.35	3.50	54 Shore A	24	610	a	c

• - Fully compliant

a - FDA Compliant with Restriction: Do not use in direct contact with fatty foods.

b - European Migration Certificate providing approval for food contact according to EU Regulation 10/2011.

c - EU compliant with Restriction: Do not use in direct contact with fatty foods.

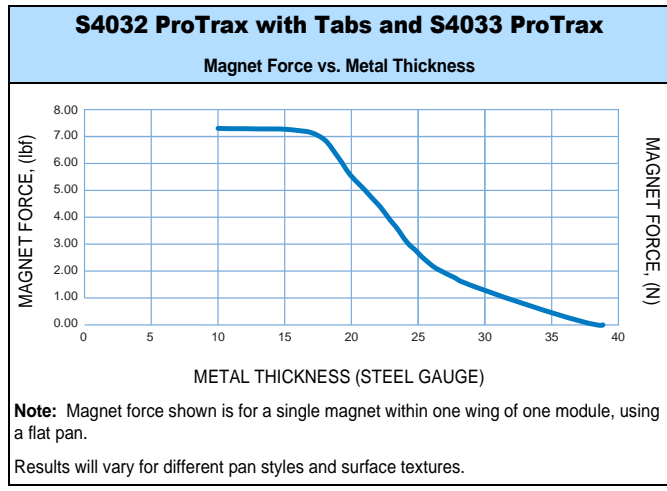
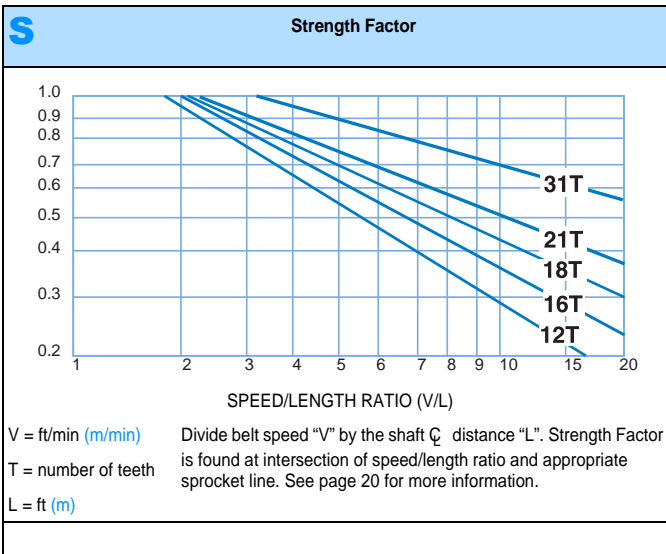

SECTION 2

4000

Plastic Sprocket^a

No. of Teeth (Chordal Action)	Nom. Pitch Dia. in	Nom. Pitch Dia. mm	Nom. Outer Dia. in	Nom. Outer Dia. mm	Nom. Hub Width in	Nom. Hub Width mm	Available Bore Sizes			
							U.S. Sizes		Metric Sizes	
							Round in	Square in	Round mm	Square mm
12 (3.41%)	3.9 ^b	99 ^b	3.9	99	1.5	38	-	1.5	-	40
15 (2.19%)	4.9	124	4.9	124	1.5	38		2.5		60
18 (1.52%)	5.7	145	5.8	148	1.5	38	2	2.5	30, 40, 50	60
24 (0.86%)	7.7	196	7.8	198	1.5	38		2.5		60



a. Contact Customer Service for lead times.
b. 3.9PD sprockets are not compatible with Series 4092 belts.

Nylon FDA Split Sprocket^a

No. of Teeth (Chordal Action)	Nom. Pitch Dia. in	Nom. Pitch Dia. mm	Nom. Outer Dia. in	Nom. Outer Dia. mm	Nom. Hub Width in	Nom. Hub Width mm	Available Bore Sizes			
							U.S. Sizes		Metric Sizes	
							Round in ^b	Square in	Round mm ^b	Square mm
16 (1.92%)	5.1	130	5.2	132	1.5	38	1 to 2 in 1-16 increments	1.5	25 to 50 in 5 increments	40

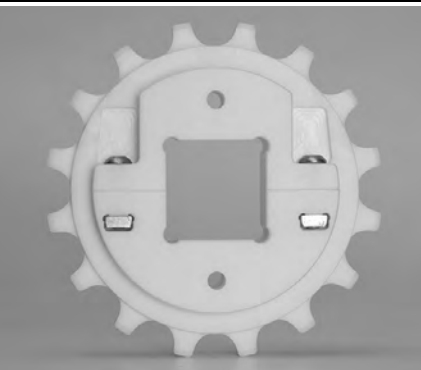

a. Contact Customer Service for lead times.
b. Imperial key sizes on round bore sprockets conform to ANSI standard B17.1-1967 (R1989) and metric key sizes conform to DIN standard 6885.

Maximum Load per Glass Filled Nylon Split Sprocket Based on Round Bore Size Range - lb (kg)														
No. of Teeth	Nom. Pitch Diameter		1 in - 1-3/16 in		1-1/4 in - 1-3/8 in		1-7/16 in - 1-3/4 in		1-13/16 in - 2 in		25 mm - 35 mm		40 mm - 50 mm	
	in	mm	lb	kg	lb	kg	lb	kg	lb	kg	lb	kg	lb	kg
18	5.7	145	300	135	340	155	400	180	540	245	240	110	410	185
21	6.7	170	225	102	275	124	350	158	500	226	175	79	400	181

Glass Filled Nylon Split Sprocket ^a													
No. of Teeth (Chordal Action)	Nom. Pitch Dia. in	Nom. Pitch Dia. mm	Nom. Outer Dia. in	Nom. Outer Dia. mm	Nom. Hub Width in	Nom. Hub Width mm	Available Bore Sizes						
							U.S. Sizes		Metric Sizes				
							Round in ^b	Square in	Round mm ^b	Square mm			
18 (1.52%)	5.7	145	5.8	148	2.0	51	1 to 2 in 1/16 increments	1.5 2.5	25 to 50 in 5 increments	40 60			
21 (1.12%)	6.7	170	6.8	172	2.0	51	1 to 2 in 1/16 increments ^c	1.5 2.5	25 to 50 in 5 increments	40 60			

- a. Contact Customer Service for lead times.
- b. Imperial key sizes on round bore sprockets conform to ANSI standard B17.1-1967 (R1989) and metric key sizes conform to DIN standard 6885.
- c. Tight fit round bores are available in 1-1/4, 1-3/16, 1-1/2, and 1-7/16 in

Polypropylene Composite Split Sprocket ^a													
No. of Teeth (Chordal Action)	Nom. Pitch Dia. in	Nom. Pitch Dia. mm	Nom. Outer Dia. in	Nom. Outer Dia. mm	Nom. Hub Width in	Nom. Hub Width mm	Available Bore Sizes						
							U.S. Sizes		Metric Sizes				
							Round in ^b	Square in	Round mm ^b	Square mm			
18 (1.52%)	5.7	145	5.8	148	2.0	51		1.5 2.5		40 60			
21 (1.12%)	6.7	170	6.8	172	2.0	51		1.5 2.5		40 60			
31 (0.51%)	9.9	251	10.1	257	2.0	51		3.5					

- a. Contact Customer Service for lead times.
- b. Imperial key sizes on round bore sprockets conform to ANSI standard B17.1-1967 (R1989) and metric key sizes conform to DIN standard 6885.

Polyurethane Composite Split Sprocket ^a													
No. of Teeth (Chordal Action)	Nom. Pitch Dia. in	Nom. Pitch Dia. mm	Nom. Outer Dia. in	Nom. Outer Dia. mm	Nom. Hub Width in	Nom. Hub Width mm	Available Bore Sizes						
							U.S. Sizes		Metric Sizes				
							Round in	Square in	Round mm	Square mm			
31 (0.51%)	9.9	251	10.1	257	1.50 1.67	38 44		3.5 2.5 ^b					

- a. Contact Customer Service for lead times.
- b. The 2.5" square bore is created by using a bore adapter in the 3.5" square bore sprocket.

Conveyor Frame Dimensions

Regardless of type or configuration, all conveyors using Intralox belts have some basic dimensional requirements. Specifically, dimensions “A”, “B”, “C” and “E” listed below should be implemented in any design.

For general applications and applications where end transfer of tip-sensitive product is not critical, use the “A” dimension at the bottom of the range.

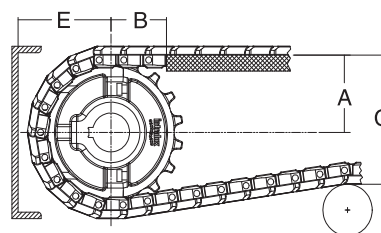

A - ± 0.031 " (1 mm)

C - \pm (Max)

B - ± 0.125 " (3 mm)

E - \pm (Min)

Complete descriptions of the dimensions are listed on page 423.

Sprocket Description		A		B		C		E		
Pitch Diameter		No. Teeth	Range (Bottom to Top)		in	mm	in	mm	in	mm
in	mm		in	mm						
SERIES 4009 FLUSH GRID										
3.9	99	12	2.07-2.14	53-54	2.31	59	4.62	117	2.73	69
5.1	130	16	2.73-2.78	69-71	2.51	64	5.90	150	3.37	86
5.7	145	18	3.05-3.10	77-79	2.54	65	6.54	166	3.69	94
6.7	170	21	3.54-3.58	90-91	2.70	69	7.50	191	4.17	106
9.9	251	31	5.15-5.18	131-132	3.15	80	10.70	272	5.77	147
SERIES 4009 FLAT TOP										
3.9	99	12	2.07-2.14	53-54	2.31	59	4.66	118	2.77	70
5.1	130	16	2.73-2.78	69-71	2.51	64	5.94	151	3.41	87
5.7	145	18	3.05-3.10	77-79	2.54	65	6.58	167	3.73	95
6.7	170	21	3.54-3.58	90-91	2.70	69	7.54	192	4.21	107
9.9	251	31	5.15-5.18	131-132	3.15	80	10.74	273	5.81	148
SERIES 4014 FLAT TOP										
3.9	99	12	2.07-2.14	53-54	2.31	59	4.24	108	2.68	68
5.1	130	16	2.73-2.78	69-71	2.51	64	5.49	139	3.64	92
5.7	145	18	3.05-3.10	77-79	2.54	65	6.09	155	3.95	100
6.7	170	21	3.54-3.58	90-91	2.70	69	7.09	180	4.43	113
9.9	251	31	5.15-5.18	131-132	3.15	80	10.86	276	5.93	151
SERIES 4030 and SERIES 4031 7.5-in PROTRAX SIDEFLEXING FLAT TOP WITH TABS										
3.9	99	12	2.07-2.17	53-54	2.31	59	4.66	118	2.77	70
5.1	130	16	2.73-2.78	67-71	2.51	64	5.989	152	3.459	88
5.8	147	18	3.05-3.10	77-79	2.54	65	6.629	168	3.779	96
6.7	170	21	3.54-3.58	90-91	2.7	69	7.589	193	4.259	108
9.9	251	31	5.15-5.18	131-132	3.15	80	10.789	274	5.859	149
SERIES 4032 7.5-in PROTRAX SIDEFLEXING FLAT TOP WITH TABS										
5.1	130	16	2.73-2.78	67-71	2.51	64	5.99	152	3.46	88
5.8	147	18	3.05-3.10	77-79	2.54	65	6.63	168	3.78	96
6.7	170	21	3.54-3.58	90-91	2.7	69	7.59	193	4.26	108
9.9	251	31	5.15-5.18	131-132	3.15	80	10.79	274	5.86	149

Sprocket Description		A		B		C		E		
Pitch Diameter		No. Teeth	Range (Bottom to Top)		in	mm	in	mm	in	mm
in	mm		in	mm						
SERIES 4033 7.5-in PROTRAX SIDEFLEXING FLAT TOP										
3.9	99	12	2.07-2.17	53-54	2.31	59	4.66	118	2.77	70
5.1	130	16	2.73-2.78	67-71	2.51	64	5.989	152	3.459	88
5.8	147	18	3.05-3.10	77-79	2.54	65	6.629	168	3.779	96
6.7	170	21	3.54-3.58	90-91	2.7	69	7.589	193	4.259	108
9.9	251	31	5.15-5.18	131-132	3.15	80	10.789	274	5.859	149
SERIES 4090, 4091, 4092 SIDEFLEXING FLAT TOP										
3.9	99	12	2.07-2.14	53-54	2.31	59	4.62	117	2.73	69
5.1	130	16	2.73-2.78	69-71	2.51	64	5.90	150	3.37	86
5.7	145	18	3.05-3.10	77-79	2.54	65	6.54	166	3.69	94
6.7	170	21	3.54-3.58	90-91	2.70	69	7.50	191	4.17	106
9.9	251	31	5.15-5.18	131-132	3.15	80	10.70	272	5.77	147
SERIES 4092 SIDEFLEXING SQUARE FRICTION TOP										
5.2	132	16	2.73-2.78	69-71	2.51	64	6.14	156	2.84	72
5.8	147	18	3.05-3.10	77-79	2.54	65	6.78	172	3.16	80
6.8	173	21	3.54-3.58	90-91	2.70	69	7.74	197	3.64	92
10.0	254	31	5.15	131	3.15	80	10.94	278	5.24	133

Dead Plate Gap

Where there is a transfer point from a belt without finger transfer plates to a dead plate, there should be a gap between the surfaces to allow for the chordal action of the belt. As the belt engages its sprockets, chordal action causes the modules to move past a *fixed* point (the tip of the dead plate) with *varying* clearances. The table below shows the minimum amount of gap which occurs at the “low point” of the modules if the tip of the dead plate just comes in contact with the “high point” as the modules pass.

In some installations it may be desirable to keep the tip of the dead plate in contact with the belt, rather than allow a gap to occur. This can be done by hinging the mounting bracket for the dead plate. This allows the dead plate to move as the modules pass, but results in a small oscillating motion which may present tipping problems for sensitive containers or products.

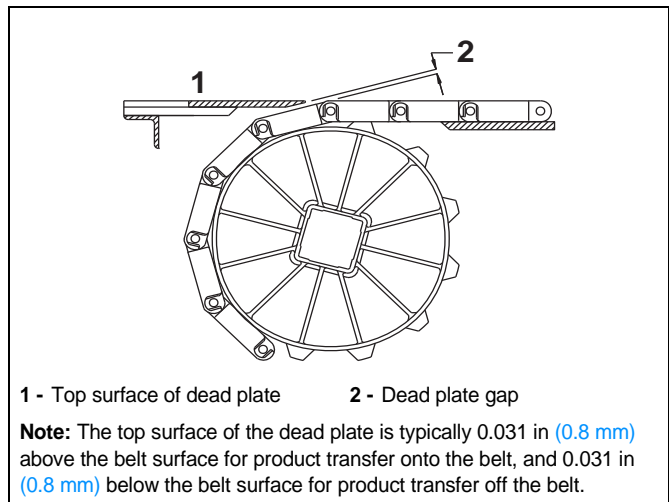

Sprocket Description			Gap	
Pitch Diameter		No. Teeth	in	mm
in	mm			
3.9	99	12	0.066	1.7
5.1	130	16	0.050	1.3
5.7	145	18	0.044	1.1
6.7	170	21	0.038	1.0
9.9	251	31	0.025	0.6

Spiralox® 1.0 Radius		
	in	mm
Pitch	2.00	50.8
Minimum Width ^a	26	660
Maximum Width ^a	50	1270
Width Increments	1.0	25.4
Opening Size (approx.)	0.85 x 0.88	21.6 x 22.5
Open Area (fully extended)	56%	
Minimum Open Area (1.0TR)	22%	
Hinge Style	Open	
Drive Method	Hinge-Driven	
Product Notes		
<ul style="list-style-type: none"> • Contact Intralox for precise belt measurements and stock status before designing equipment or ordering a belt. • Designed for low-tension, capstan drive spiral applications with a minimum turn radius of 1.0 times the belt width (measured from inside edge). • The Intralox Spiral Program will help predict the strength requirements of most low-tension, capstan drive spiral applications, ensuring that the belt is strong enough for the application. Contact Intralox Technical Support for more information. • Lightweight, relatively strong belt with smooth surface grid. • Minimum sprocket indent from the inside (collapsed) edge of the spiral is 12 in (304.8 mm). • Uses headless rods. • Contact Customer Service for preferred run direction on spiral applications. <p>WARNING: Do not place fingers in or on this belt. Fingers can get trapped in belt openings, resulting in personal injury. This belt has pinch points due to the belt spreading and collapsing as it flexes to follow the conveyor path. Pinch points can trap fingers, hair, or clothing, causing personal injury. Do not wear loose clothing, loose gloves, or hand/finger jewelry when working near this belt. Call Customer Service for tags, flyers, and stickers containing this warning.</p>		
Additional Information		
<ul style="list-style-type: none"> • See "Belt Selection Process" (page 5) • See "Standard Belt Materials" (page 9) • See "Special Application Belt Materials" (page 9) • See "Friction Factors" (page 13) 		

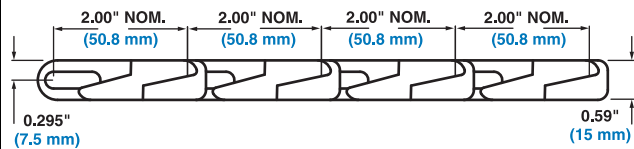
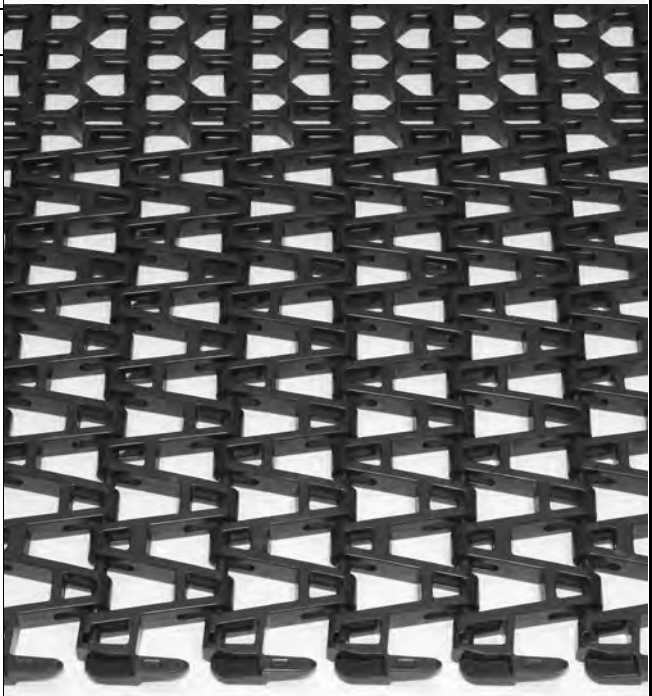

a. Contact Intralox Customer Service for more information regarding belt widths under 26 in (660 mm) and over 50 in (1270 mm).

Belt Data										
Belt Material	Standard Rod Material Ø 0.24 in (6.1 mm)	BS	Straight Belt Strength		Spiral Belt Strength ^a		Temperature Range (continuous)		W	Belt Weight
			lb/ft	kg/m	lbs	kg	°F	°C		
Acetal	Acetal		1300	1935	300	136	-50 to 200	-46 to 93	1.46	7.13
SELM	Acetal		1300	1935	300	136	-50 to 200	-46 to 93	1.24	6.05

a. Published spiral belt strengths and their method of calculation vary among spiral belt manufacturers. Please consult an Intralox Spiral Engineer for accurate comparison of spiral belt strengths.

Spiralox® 1.1 Radius

	in	mm
Pitch	2.00	50.8
Minimum Width ^a	26	660
Maximum Width ^a	44	1118
Width Increments	1.00	25.4
Opening Size (approximate)	0.85 × 0.88	21.6 × 22.5
% Open Area (fully extended)	56%	
% Minimum Open Area (1.1 Turn Ratio)	22%	
Hinge Style	Open	
Drive Method	Hinge-driven	

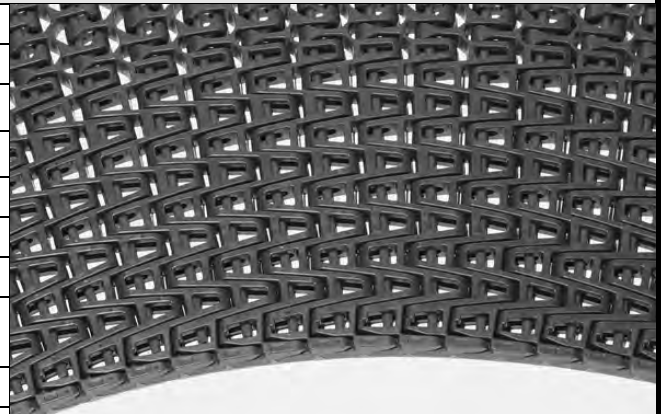

Product Notes

- **Contact Intralox for precise belt measurements and stock status before designing equipment or ordering a belt.**
- Designed for low-tension, capstan drive spiral applications with a minimum turn radius of 1.1 times the belt width (measured from inside edge).
- Uses headless rods.
- The Intralox Spiral Program will help predict the strength requirements of most low-tension, capstan drive spiral applications, ensuring that the belt is strong enough for the application. Contact Intralox Technical Support for more information.
- Lightweight, relatively strong belt with smooth surface grid.
- Belt openings pass straight through the belt, making the belt easy to clean.
- Minimum sprocket indent from the inside (collapsed) edge of the spiral is 9.0 in (228.6 mm).
- Contact Customer Service for preferred run direction on spiral applications.

WARNING: Do not place fingers in or on this belt. Fingers can get trapped in belt openings, resulting in personal injury. This belt has pinch points due to the belt spreading and collapsing as it flexes to follow the conveyor path. Pinch points can trap fingers, hair, or clothing, causing personal injury. Do not wear loose clothing, loose gloves, or hand/finger jewelry when working near this belt. Call Customer Service for tags, flyers, and stickers containing this warning.

Additional Information

- See “Belt Selection Process” (page 5)
- See “Standard Belt Materials” (page 9)
- See “Special Application Belt Materials” (page 9)
- See “Friction Factors” (page 13)

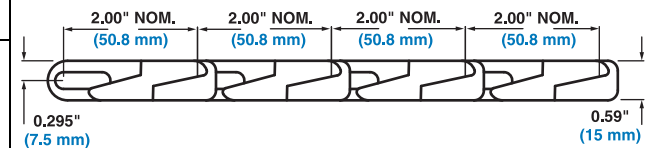
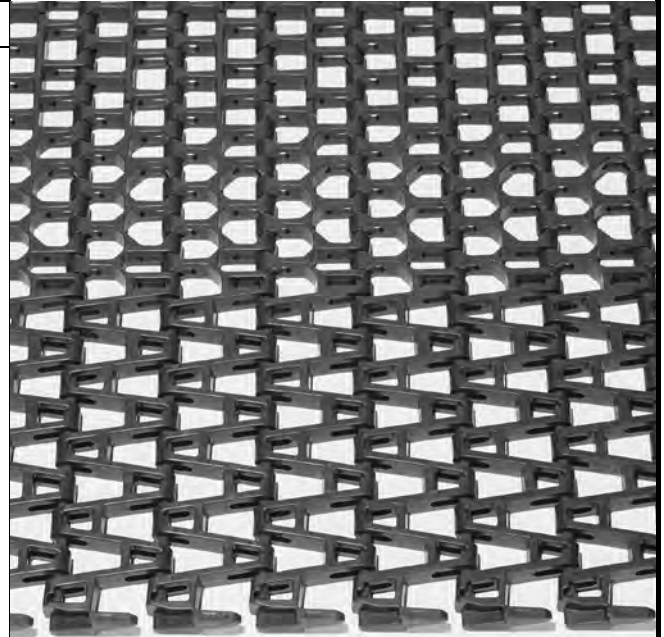

a. Contact Intralox Customer Service for more information regarding belt widths under 26 in (660mm) and over 44 in (1118mm).

Belt Data

Belt Material	Standard Rod Material Ø 0.24 in (6.1 mm)	BS		Straight Belt Strength		Spiral Belt Strength ^a		Temperature Range (continuous)		W Belt Weight	
		lb/ft	kg/m	lbs	kg	°F	°C	lb/ft ²	kg/m ²		
Acetal	Acetal	1300	1935	300	136	-50 to 200	-46 to 93	1.44	7.03		
SELM	Acetal	1300	1935	300	136	-50 to 200	-46 to 93	1.24	6.05		

a. Published spiral belt strengths and their method of calculation vary among spiral belt manufacturers. Please consult an Intralox Spiral Engineer for accurate comparison of spiral belt strengths.

Spiralox® 1.6, 2.0 Radius		
	in	mm
Pitch	2.00	50.8
Minimum Width ^a	24	610
Maximum Width	60	1524
Width Increments	1.00	25.4
Opening Size (approximate)	0.94 × 0.65	23.8 × 16.5
% Open Area (fully extended)	54%	
% Minimum Open Area (1.6 Turn Ratio)	40%	
Hinge Style	Open	
Drive Method	Hinge-driven	

Product Notes

- **Contact Intralox for precise belt measurements and stock status before designing equipment or ordering a belt.**
- Designed for low-tension, capstan drive spiral applications with a minimum turn radius of 1.6 times the belt width (measured from inside edge).
- Uses headless rods.
- The Intralox Spiral Program will help predict the strength requirements of most low-tension, capstan drive spiral applications, ensuring that the belt is strong enough for the application. Contact Intralox Technical Support for more information.
- Lightweight, relatively strong belt with smooth surface grid.
- Belt openings pass straight through the belt, making the belt easy to clean.
- Contact Customer Service for preferred run direction on spiral applications.

WARNING: Do not place fingers in or on this belt. Fingers can get trapped in belt openings, resulting in personal injury. This belt has pinch points due to the belt spreading and collapsing as it flexes to follow the conveyor path. Pinch points can trap fingers, hair, or clothing, causing personal injury. Do not wear loose clothing, loose gloves, or hand/finger jewelry when working near this belt. Call Customer Service for tags, flyers, and stickers containing this warning.

Additional Information

- See "Belt Selection Process" (page 5)
- See "Standard Belt Materials" (page 9)
- See "Special Application Belt Materials" (page 9)
- See "Friction Factors" (page 13)

a. Contact Intralox Customer Service for more information regarding belt widths under 24" (610mm).

Belt Data									
Belt Material	Standard Rod Material Ø 0.24 in (6.1 mm)	BS Straight Belt Strength		Spiral Belt Strength ^a		Temperature Range (continuous)		W Belt Weight	
		lb/ft	kg/m	lbs	kg	°F	°C	lb/ft ²	kg/m ²
Acetal	Acetal	1700	2530	375	170	-50 to 200	-46 to 93	1.41	6.88
Poylpropylene ^b	Acetal	1500	2232	300	136	34 to 200	1 to 93	1.01	4.93
SELM	Acetal	1500	2232	300	136	-50 to 200	-46 to 93	1.24	6.05

a. Published spiral belt strengths and their method of calculation vary among spiral belt manufacturers. Please consult an Intralox Spiral Engineer for accurate comparison of spiral belt strengths.
b. Available in 1.6 Radius only.

Spiralox® 2.2, 2.5, and 3.2 Radius

	in	mm
Pitch	2.00	50.8
Minimum Width ^a	24	610
Maximum Width	60	1524
Width Increments	1.00	25.4
Opening Size (approximate)	0.94 × 0.65	23.8 × 16.5
% Open Area (fully extended)	57%	
% Minimum Open Area (2.2 Turn Ratio)	32%	
Hinge Style	Open	
Drive Method	Hinge-driven	

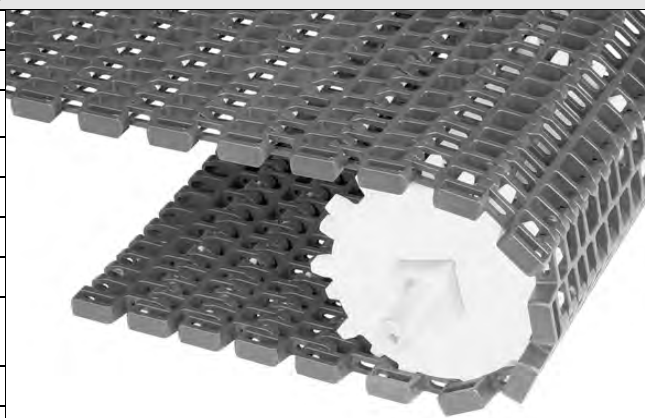

Product Notes

- Contact Intralox for precise belt measurements and stock status before designing equipment or ordering a belt.
- Designed for low-tension, capstan drive spiral applications with a minimum turn radius of 2.2 times the belt width (measured from inside edge).
- The Intralox Spiral Program will help predict the strength requirements of most low-tension, capstan drive spiral applications, ensuring that the belt is strong enough for the application. Contact Intralox Technical Support for more information.
- Lightweight, relatively strong belt with smooth surface grid.
- Belt openings pass straight through the belt, making the belt easy to clean.
- Uses headless rods.
- Contact Customer Service for preferred run direction on spiral applications.

WARNING: Do not place fingers in or on this belt. Fingers can get trapped in belt openings, resulting in personal injury. This belt has pinch points due to the belt spreading and collapsing as it flexes to follow the conveyor path. Pinch points can trap fingers, hair, or clothing, causing personal injury. Do not wear loose clothing, loose gloves, or hand/finger jewelry when working near this belt. Call Customer Service for tags, flyers, and stickers containing this warning.

Additional Information

- See “Belt Selection Process” (page 5)
- See “Standard Belt Materials” (page 9)
- See “Special Application Belt Materials” (page 9)
- See “Friction Factors” (page 13)

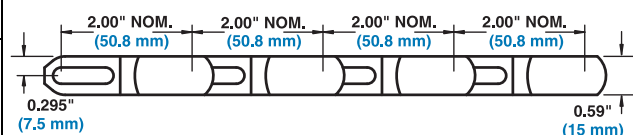
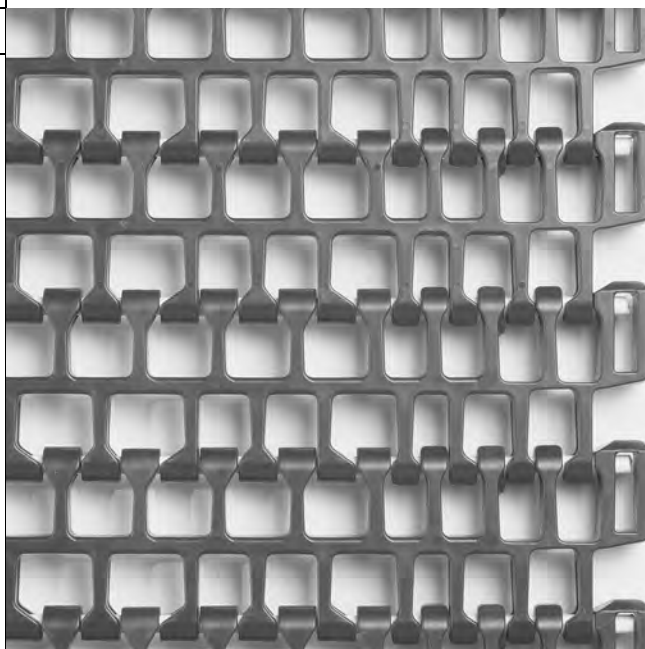

a. Contact Intralox Customer Service for more information regarding belt widths under 24" (610mm).

Belt Data

Belt Material	Standard Rod Material Ø 0.24 in (6.1 mm)	BS	Straight Belt Strength		Spiral Belt Strength ^a		Temperature Range (continuous)		W	Belt Weight	
			lb/ft	kg/m	lbs	kg	°F	°C		lb/ft ²	kg/m ²
Acetal	Acetal		1700	2530	475	215	-50 to 200	-46 to 93	1.54	7.52	
Poylpropylene	Acetal		1500	2232	400	181	34 to 200	1 to 93	1.04	5.08	
SELM	Acetal		1500	2232	375	170	-50 to 200	-46 to 93	1.24	6.05	

a. Published spiral belt strengths and their method of calculation vary among spiral belt manufacturers. Please consult an Intralox Spiral Engineer for accurate comparison of spiral belt strengths.

Spiralox® Rounded Friction Top		
	in	mm
Pitch	2.00	50.8
Minimum Width ^a	24	610
Maximum Width	60	1524
Width Increments	1.00	25.4
Opening Size (approximate)	0.94 × 0.65	23.8 × 16.5
Hinge Style	Open	
Drive Method	Hinge-driven	

Product Notes

- Contact Intralox for precise belt measurements and stock status before designing equipment or ordering a belt.
- The Intralox Spiral Program will help predict the strength requirements of most low-tension, capstan drive spiral applications, ensuring that the belt is strong enough for the application. Contact Intralox Technical Support for more information.
- Friction top available in white polypropylene with white rubber, blue polypropylene with black rubber, and natural polyethylene with white rubber.
- Lightweight, relatively strong belt with smooth surface grid.
- Belt openings pass straight through the belt, making the belt easy to clean.
- Uses headless rods.
- Contact Customer Service for preferred run direction on spiral applications.
- Contact Customer service for minimum indent requirements.

WARNING: Do not place fingers in or on this belt. Fingers can get trapped in belt openings, resulting in personal injury. This belt has pinch points due to the belt spreading and collapsing as it flexes to follow the conveyor path. Pinch points can trap fingers, hair, or clothing, causing personal injury. Do not wear loose clothing, loose gloves, or hand/finger jewelry when working near this belt. Call Customer Service for tags, flyers, and stickers containing this warning.

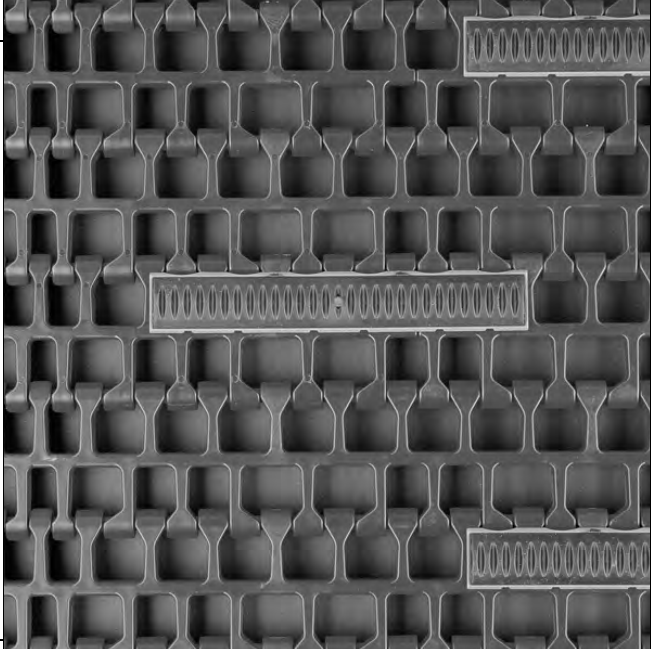
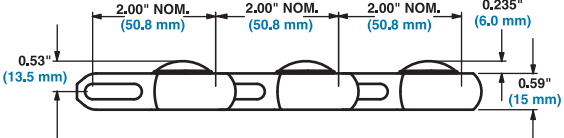
Additional Information	
<ul style="list-style-type: none"> See "Belt Selection Process" (page 5) See "Standard Belt Materials" (page 9) See "Special Application Belt Materials" (page 9) See "Friction Factors" (page 13) 	

a. Contact Intralox Customer Service for more information regarding belt widths under 24 in (610mm).

Belt Data													
Base Belt Material	Base/Friction Color	Standard Rod Material Ø 0.24 in (6.1 mm)	BS Belt Strength		Spiral Belt Strength 1.6 TR (2.2, 2.5, 3.2 TR)		Temperature Range (continuous)		W Belt Weight		Friction Top Hardness	Agency Acceptability	
			lb/ft	kg/m	lb	kg	°F	°C	lb/ft ²	kg/m ²		FDA (USA)	EU MC ^b
Acetal	Blue/Black	Acetal	1700	2530	375 (475)	170 (215)	34 to 150	1 to 66	1.44 (1.54)	7.03 (7.52)	55 Shore A	•	c
Acetal	White/White	Acetal	1700	2530	376 (475)	171 (215)	35 to 150	2 to 66	1.44 (1.54)	7.03 (7.52)	55 Shore A	a	c
Polypropylene	Blue/Black	Acetal	1500	2232	300 (400)	136 (181)	34 to 150	1 to 66	1.01 (1.04)	4.93 (5.08)	55 Shore A	a	c
Polypropylene	White/White	Acetal	1500	2232	300 (400)	136 (181)	34 to 150	1 to 66	1.01 (1.04)	4.93 (5.08)	55 Shore A	a	c

• - Fully compliant

a - FDA Compliant with Restriction: Do not use in direct contact with fatty foods.

b - European Migration Certificate providing approval for food contact according to EU Regulation 10/2011.

c - EU compliant with Restriction: Do not use in direct contact with fatty foods.

Dual Turning 2.0

	in	mm
Pitch	2.00	50.8
Minimum Width	18	457.2
Maximum Width	60	1524
Width Increments	1.0	25.4
Opening Size (approx.)	0.94 x 0.65	23.8 x 16.5
Open Area (fully extended)	57%	
Hinge Style	Open	
Drive Method	Hinge-Driven	



Product Notes

DO NOT USE IN SPIRAL CONVEYOR SYSTEMS.

- Contact Intralox for precise belt measurements and stock status before designing equipment or ordering a belt.
- Rod insertion is accomplished from edge of belt. No special tools are required.
- Uses headless rods.
- Designed for standard drive and i-Drive systems.
- Turn ratios of 2.0 times belt width (radius measured at inside edge).
- Preferred run direction is to align with slotted holes leading.
- Consult Engineering Program/i-Drive Program for specific widths not listed in this product data.

WARNING: Do not place fingers in or on this belt. Fingers can get trapped in belt openings, resulting in personal injury. This belt has pinch points due to the belt spreading and collapsing as it flexes to follow the conveyor path. Pinch points can trap fingers, hair, or clothing, causing personal injury. Do not wear loose clothing, loose gloves, or hand/finger jewelry when working near this belt. Call Customer Service for tags, flyers, and stickers containing this warning.

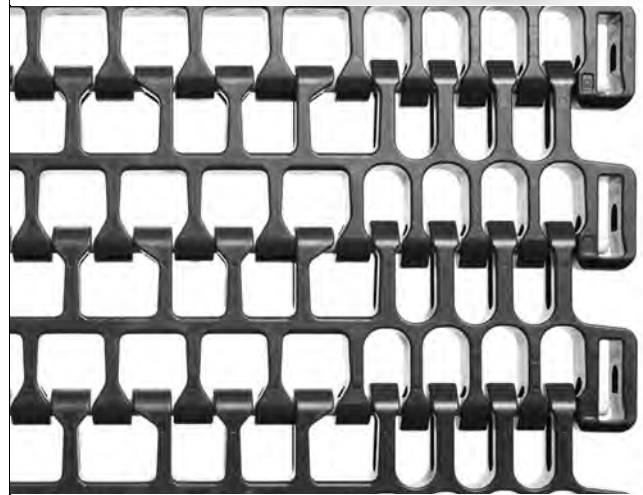

Additional Information

- See "Belt Selection Process" (page 5).
- See "Standard Belt Materials" (page 9).
- See "Special Application Belt Materials" (page 9).

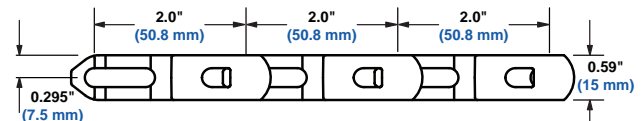

Belt Data

Base Belt Material	Standard Rod Material Ø 0.24 in (6.1 mm)	BS Straight Belt Strength		Curved Belt Strength ^a Belt Widths						Temperature Range (continuous)		W Belt Weight	
				18 in 457 mm		24 in 610 mm		36 in 914 mm		°F	°C		
		lb/ft	kg/m	lbs	kg	lbs	kg	lbs	kg			lb/ft ²	kg/m ²
Acetal	Acetal	1700	2530	213	97	300	136	475	215	-50 to 200	-46 to 93	1.54	7.52
Polypropylene	Acetal	1500	2232	190	86	260	118	400	181	34 to 200	1 to 93	1.04	5.08
SELM	Acetal	990	1473	108	49	144	65	215	98	-50 to 200	-46 to 93	1.24	6.05

a. Published curved belt strengths and their method of calculation vary among radius belt manufacturers. Please consult an Intralox Sales Engineer for accurate comparison of curve belt strengths. Curved belt strength does not change above 36 in (914 mm).

Sprocket and Support Quantity Reference^a

Belt Width Range ^b		Minimum Number of Sprockets Per Shaft ^c	Wearstrips	
in.	mm		Carryway	Returnway
24	610	3	3	3
26	660	3	3	3
28	711	5	3	3
30	762	5	3	3
32	813	5	3	3
34	864	5	3	3
36	914	5	3	3
38	965	5	4	4
40	1016	5	4	4
42	1067	5	4	4
44	1118	7	4	4
46	1168	7	4	4
48	1219	7	4	4
50	1270	7	4	4
52	1321	7	4	4
54	1372	7	5	5
56	1422	7	5	5
58	1473	7	5	5
60	1524	9	5	5
For Other Widths, Use Odd Number of Sprockets at Maximum 6 in. (152 mm) \varnothing Spacing			Contact Technical Support Group	Maximum 12 in. (305 mm) \varnothing Spacing

- a. For low-tension capstan drive spirals contact Technical Support Group for suggested carryway support recommendations. Belt edges must be supported by support rollers on drive shafts. Contact Technical Support Group for more information.
- b. If your belt width exceeds a number listed in the table, please refer to the sprocket and support material minimums for the next larger width range listed. Belts are available in 1.00 in. (25.4 mm) increments beginning with minimum width of 24 in. (610 mm). **If the actual width is critical, consult Customer Service.**
- c. These are the minimum number of sprockets. Additional sprockets may be required for heavily loaded applications. See Retainer Rings/Center Sprocket Offset chart on page 410 for lock down location.

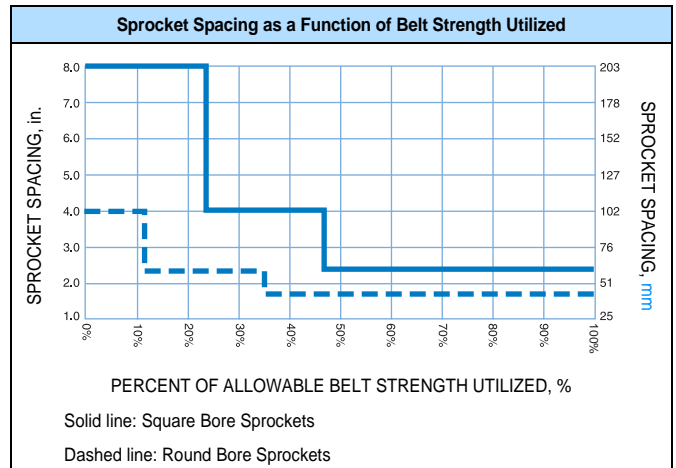
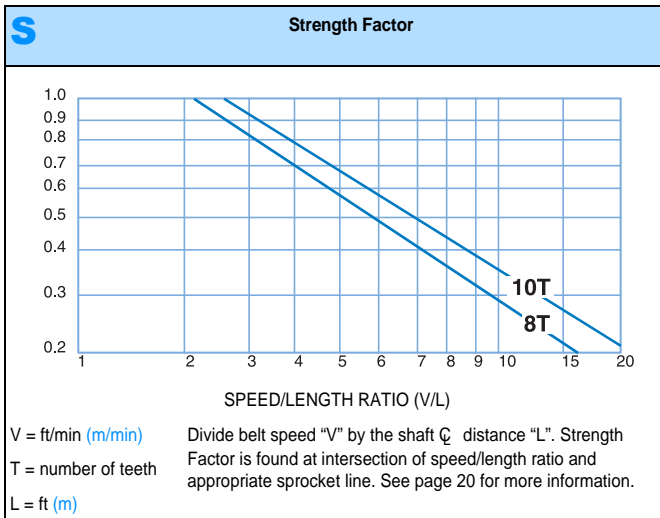

UHMW Polyethylene Sprocket ^a										
No. of Teeth (Chordal Action)	Nom. Pitch Dia. in.	Nom. Pitch Dia. mm	Nom. Outer Dia. in.	Nom. Outer Dia. mm	Nom. Hub Width in.	Nom. Hub Width mm	Available Bore Sizes			
							U.S. Sizes		Metric Sizes	
							Round in.	Square in.	Round mm	Square mm
8 (7.61%)	5.2	132	5.4	136	0.8	20.32	1-1/4	1-1/2		40 60
							1-7/16	2-1/2		
							1-1/2	2		
10 (4.89%)	6.5	165	6.7	170	0.8	20.32	1-1/4	1-1/2		40 60
							1-7/16	2-1/2		
							1-1/2	2		

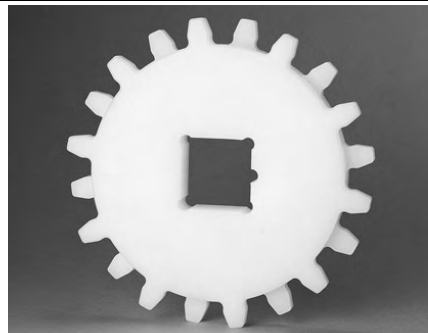

a. Contact Customer Service for lead times, preferred method of locking down sprockets, and for proper sprocket timing.

EZ Clean Sprocket ^a										
No. of Teeth (Chordal Action)	Nom. Pitch Dia. in.	Nom. Pitch Dia. mm	Nom. Outer Dia. in.	Nom. Outer Dia. mm	Nom. Hub Width in.	Nom. Hub Width mm	Available Bore Sizes			
							U.S. Sizes		Metric Sizes	
							Round in.	Square in.	Round mm	Square mm
10 (4.89%)	6.5	165	6.7	170	0.8	20.32		2-1/2		



a. Contact Customer Service for lead times.

Support Wheel					
Available Pitch Diameter		Available Bore Sizes			
in.	mm	U.S. Sizes		Metric Sizes	
		Round in.	Square in.	Round mm	Square mm
5.2	132	1.25	1.5		40
		1-7/16	2.5		60
		1.5			
6.5	165	1.25	1.5		40
		1-7/16	2.5		60
		1.5			
		2			

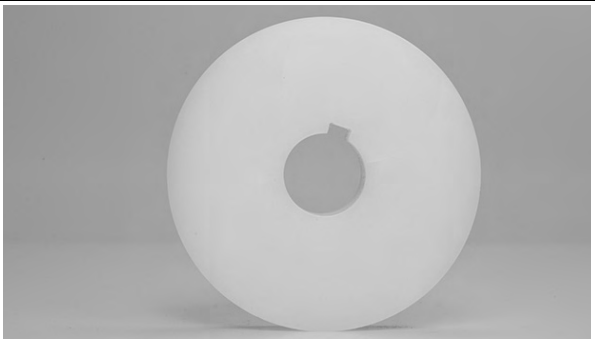

Universal Sideguards		
Available Height		Available Materials
in.	mm	
0.50	12.7	Acetal, SELM
1.00	25.4	
2.00 ^a	50.8 ^a	





Note: Maximizes product carrying capacity: they fit into the very edge of the belt, with no indent.

Note: Assembly does not require "finger cuts" on the modules, so the belt's beam strength is uncompromised.

Note: Turn ratios that Universal Sideguards can be used in are 1.6, 2.2, 2.5, and 3.2.

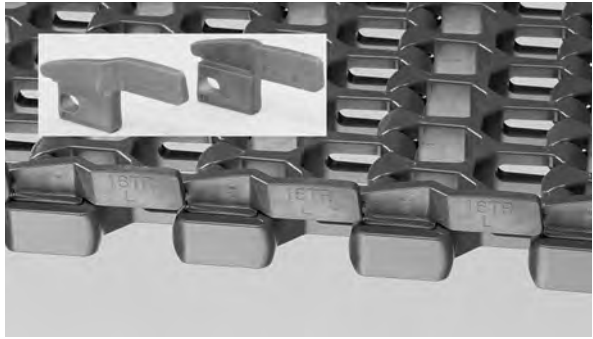
a. Only available in 1.6 TR

Overlapping Sideguards		
Available Height		Available Materials
in.	mm	
0.50	12.7	Acetal, SELM
1.00	25.4	
<p>Note: Maximizes product carrying capacity: they fit into the very edge of the belt, with no indent.</p> <p>Note: Assembly does not require “finger cuts” on the modules, so the belt’s beam strength is uncompromised.</p> <p>Note: Turn ratios for 0.50 in (12.7 mm) Overlapping Sideguards in Acetal are 1.6, 2.2, 2.5, and 3.2.</p> <p>Note: The turn ratio for 1.00 in (25.4 mm) Overlapping Sideguards is 1.6 only.</p> <p>Note: Makes the belt’s outer edge more snag-resistant.</p> <p>Note: Keeps small products from falling through belt gaps.</p>		
		

Lane Dividers		
Available Height		Available Materials
in.	mm	
0.75	19.0	Acetal, Polypropylene
<p>Note: Assembly does not require “finger cuts” on the modules, so the belt’s beam strength is uncompromised.</p> <p>Note: For 1.6 Turning Radius modules the Lane Dividers can be placed on indents of 1.5" (38.1 mm), 2.5" (63.5 mm), 3.5" (88.9 mm), 4.5" (114 mm), 11.5" (292 mm), and up in 1.00" (25.4 mm) increments .</p> <p>Note: For 2.2 Turning Radius modules the Lane Dividers can be placed on indents of 4.5" (114 mm) and up in 1.00" (25.4 mm) increments .</p>		
		

Conveyor Frame Dimensions

Regardless of type or configuration, all conveyors using Intralox belts have some basic dimensional requirements. Specifically, dimensions “A”, “B”, “C” and “E” listed below should be implemented in any design.

For general applications and applications where end transfer of tip-sensitive product is not critical, use the “A” dimension at the bottom of the range.

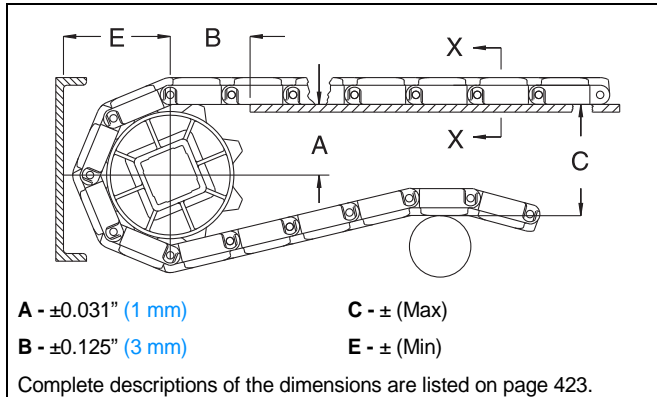

Sprocket Description					A		B		C		E	
Pitch Diameter		Nominal OD		No. Teeth	Range (Bottom to Top)		in.	mm	in.	mm	in.	mm
in.	mm	in.	mm		in.	mm						
SERIES 2600 SPIRALOX® 1.0 RADIUS, 1.1 RADIUS, 1.6 RADIUS, 2.0 RADIUS, 2.2 RADIUS, 2.5 RADIUS, 3.2 RADIUS												
5.2	132	5.4	137	8	2.12-2.32	54-59	2.25	57	5.23	133	2.97	75
6.5	165	6.7	170	10	2.78-2.94	71-75	2.54	65	6.47	164	3.59	91
SERIES 2600 SPIRALOX® ROUNDED FRICTION TOP												
5.2	132	5.4	137	8	2.12-2.32	54-59	2.25	57	5.46	139	3.21	82
6.5	165	6.7	170	10	2.78-2.94	71-75	2.54	65	6.71	170	3.83	97

Dead Plate Gap

Where there is a transfer point from a belt without finger transfer plates to a dead plate, there should be a gap between the surfaces to allow for the chordal action of the belt. As the belt engages its sprockets, chordal action causes the modules to move past a *fixed* point (the tip of the dead plate) with *varying* clearances. The table below shows the minimum amount of gap which occurs at the “low point” of the modules if the tip of the dead plate just comes in contact with the “high point” as the modules pass.

In some installations it may be desirable to keep the tip of the dead plate in contact with the belt, rather than allow a gap to occur. This can be done by hinging the mounting bracket for the dead plate. This allows the dead plate to move as the modules pass, but results in a small oscillating motion which may present tippage problems for sensitive containers or products.

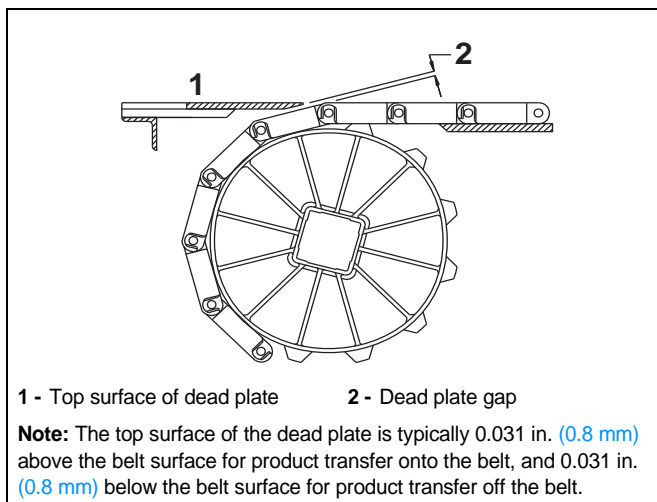

Sprocket Description				Gap	
Pitch Diameter		No. Teeth	in.	mm	
in.	mm				
5.2	132	8	0.200	5.1	
6.5	165	10	0.158	4.0	

HOLD DOWN RAILS AND WEARSTRIPS

Intralox recommends using continuous hold down rails through an entire turn, starting at a distance of 1X the belt width before the turn and ending 1X the belt width after the

turn. This applies to both carryway and returnway. The use of hold down rails along both side of the belt over the full carryway is recommended but not mandatory. See “*Custom wearstrips*” (page 416).

FLUSH EDGE WITH WEARSTRIP

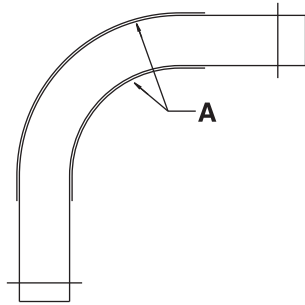

A - HOLD DOWN RAIL PLACEMENT

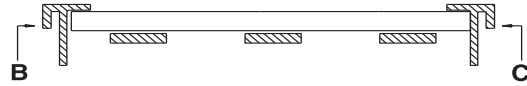

B - OUTSIDE HOLD DOWN RAIL

C - INSIDE HOLD DOWN RAIL

Fig. 2-8 HOLD DOWN RAILS AND WEARSTRIPS FOR SERIES 2600 FLAT-TURNS

BELT SELECTION INSTRUCTIONS

ENGINEERING PROGRAM ANALYSIS FOR SERIES 2600

Intralox Customer Service Technical Support Group can calculate the estimated belt pull for radius applications using **Series 2600**. The following information is required (refer to “*Radius belt data sheet*” (page 469)):

- Any environmental conditions which may affect the friction coefficient (for dirty or abrasive conditions, use higher friction coefficients than normal)
- Belt width
- Length of each straight run
- Turning angle of each turn

- Turn direction of each turn
- Inside turning radius of each turn
- Carryway/hold down rail material
- Product loading lb/ft² (kg/m²)
- Product back-up conditions
- Belt speed
- Elevation changes on each section
- Operating temperatures.

For assistance with radius belt and low-tension capstan drive spiral selections, contact Intralox Customer Service Technical Support Group. The Engineering Program should be run to ensure that the belt is strong enough for the radius application in question.

SERIES 2600 DESIGN GUIDE SUMMARY

For more information, see the *Installation, Maintenance and Troubleshooting manual* available from Intralox.

- A** - The minimum turning radius for **Series 2600** is the turning radius times the belt width, measured from the inside edge.
- B** - The minimum straight run required between turns of opposing direction is 2.0 times the belt width. Shorter straight sections will lead to high wear on the edge guide rail and high pull stresses in the belt.
- C** - There is no minimum straight run required between turns that are in the same direction.
- D** - The minimum final straight run (leading to the drive shaft) should be a minimum of 5 ft. (1.5 m). If 5 ft. (1.5 m) is not feasible, then a shorter distance (down to 1.5 times the belt width) would require a weighted take up in order to avoid sprocket wear and tracking problems. See "Special Take-Up Arrangements" (page 431).
- E** - The minimum length of the first straight run (immediately after the idle shaft) is 1.5 times the belt width. When shorter lengths are required (down to 1.0 times the width), an idle roller may be used in place of sprockets.
- F** - IDLE SHAFT
- G** - 1ST TURN
- H** - BELT WIDTH
- I** - BELT TRAVEL
- J** - 2ND TURN
- K** - DRIVE MOTOR
- L** - DRIVE SHAFT

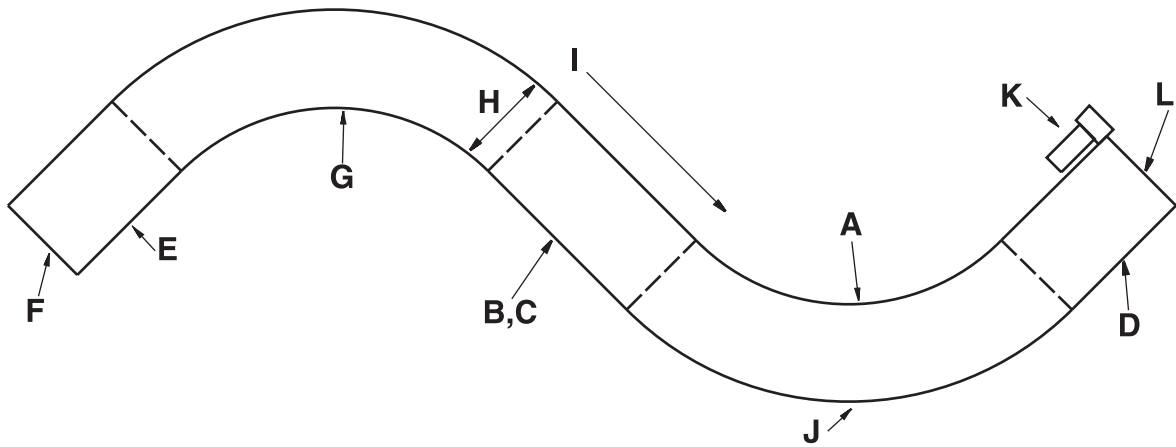
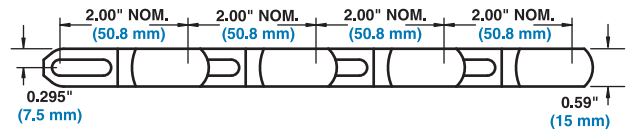
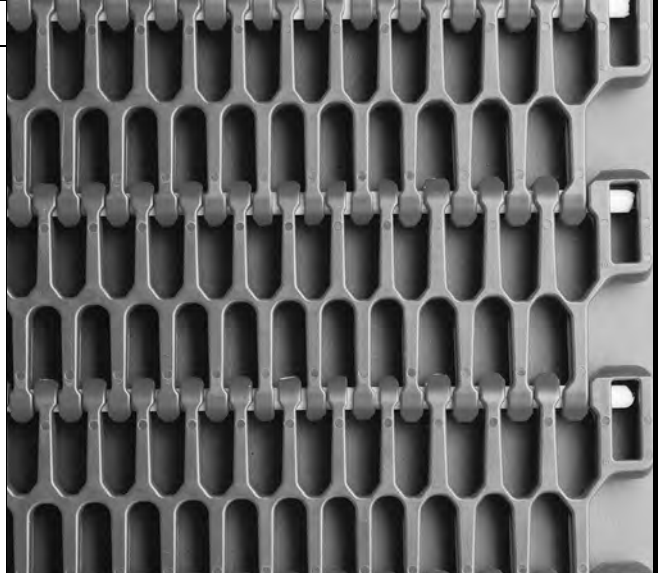
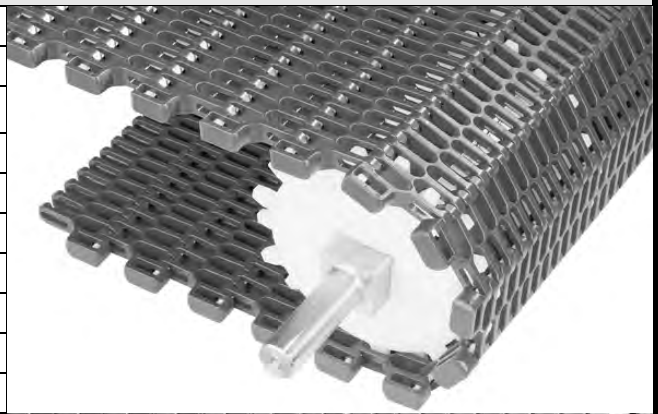

Fig. 2-9 TYPICAL 2-TURN RADIUS LAYOUT

Spiralox® 1.6 Radius		
	in	mm
Pitch	2.00	50.8
Minimum Width ^a	24	610
Maximum Width	60	1524
Width Increments	0.50	12.7
Opening Size (approximate)	0.38 × 0.64	9.52 × 16.5
Open Area (fully extended)	45%	
Min. Open Area (1.6 TR)	27%	
Hinge Style	Open	
Drive Method	Hinge-driven	
Product Notes		
<ul style="list-style-type: none"> • Contact Intralox for precise belt measurements and stock status before designing equipment or ordering a belt. • Designed for low-tension, capstan drive spiral applications with a minimum turn radius of 1.6 times the belt width (measured from inside edge). • The Intralox Spiral Program will help predict the strength requirements of most low-tension, capstan drive spiral applications, ensuring that the belt is strong enough for the application. Contact Intralox Technical Support for more information. • Lightweight, relatively strong belt with smooth surface grid. • Belt openings pass straight through the belt, making the belt easy to clean. • Uses headless rods. • Contact Customer Service for preferred run direction on spiral applications. <p>WARNING: Do not place fingers in or on this belt. Fingers can get trapped in belt openings, resulting in personal injury. This belt has pinch points due to the belt spreading and collapsing as it flexes to follow the conveyor path. Pinch points can trap fingers, hair, or clothing, causing personal injury. Do not wear loose clothing, loose gloves, or hand/finger jewelry when working near this belt. Call Customer Service for tags, flyers, and stickers containing this warning.</p>		
Additional Information		
<ul style="list-style-type: none"> • See “Belt Selection Process” (page 5) • See “Standard Belt Materials” (page 9) • See “Special Application Belt Materials” (page 9) • See “Friction Factors” (page 13) 		



a. Contact Intralox Customer Service for more information regarding belt widths under 24 in (610 mm).

Belt Data									
Belt Material	Standard Rod Material Ø 0.24 in (6.1 mm)	BS Straight Belt Strength	Spiral Belt Strength ^a		Temperature Range (continuous)		W Belt Weight		
			lb/ft	kg/m	lb	kg	°F	°C	lb/ft ²
Acetal	Acetal	2000	2976	375	170	-50 to 200	-46 to 93	1.74	8.50
SELM	Acetal	1060	1577	300	136	-50 to 200	-46 to 93	1.36	6.64

a. Published spiral belt strengths and their method of calculation vary among spiral belt manufacturers. Please consult an Intralox Spiral Engineer for accurate comparison of spiral belt strengths.

Spiralox® 2.2 Radius

	in	mm
Pitch	2.00	50.8
Minimum Width ^a	24	610
Maximum Width	60	1524
Width Increments	0.50	12.7
Opening Size (approx.)	0.38 x 0.64	9.52 x 16.5
Open Area (fully extended)	48%	
Min. Open Area (2.2 TR)	23%	
Hinge Style	Open	
Drive Method	Hinge-Driven	

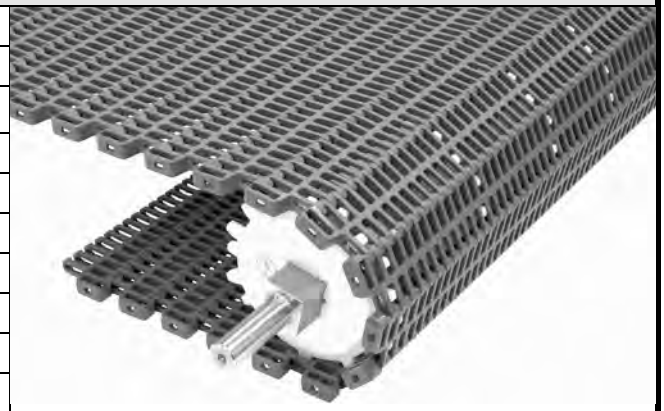

Product Notes

- Contact Intralox for precise belt measurements and stock status before designing equipment or ordering a belt.
- Designed for low-tension, capstan drive spiral applications with a minimum turn radius of 2.2 times the belt width (measured from inside edge).
- The Intralox Spiral Program will help predict the strength requirements of most low-tension, capstan drive spiral applications, ensuring that the belt is strong enough for the application. Contact Intralox Technical Support for more information.
- Lightweight, relatively strong belt with smooth surface grid.
- Belt openings pass straight through the belt, making the belt easy to clean.
- Uses headless rods.
- Contact Customer Service for preferred run direction on spiral applications.

WARNING: Do not place fingers in or on this belt. Fingers can get trapped in belt openings, resulting in personal injury. This belt has pinch points due to the belt spreading and collapsing as it flexes to follow the conveyor path. Pinch points can trap fingers, hair, or clothing, causing personal injury. Do not wear loose clothing, loose gloves, or hand/finger jewelry when working near this belt. Call Customer Service for tags, flyers, and stickers containing this warning.

Additional Information

- See “Belt Selection Process” (page 5)
- See “Standard Belt Materials” (page 9)
- See “Special Application Belt Materials” (page 9)
- See “Friction Factors” (page 13)

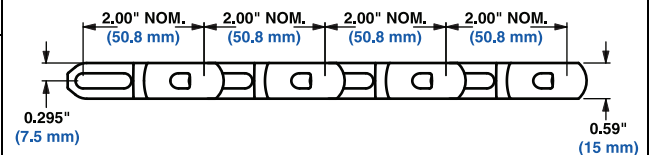
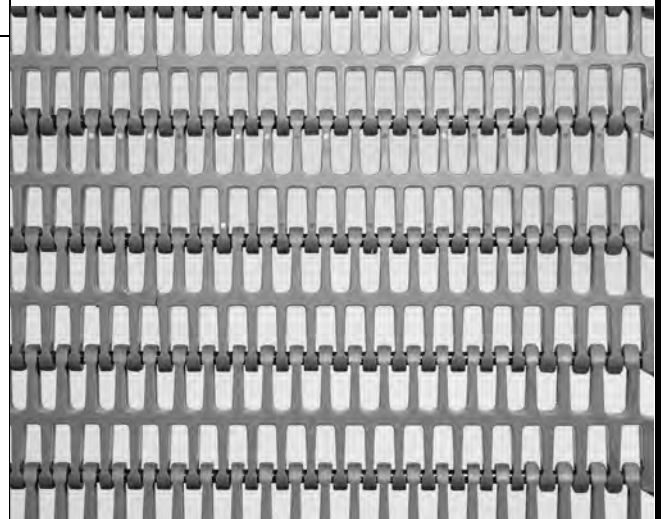

a. Contact Intralox Customer Service for more information regarding belt widths under 24 in (610 mm).

Belt Data

Belt Material	Standard Rod Material Ø 0.24 in (6.1 mm)	BS Straight Belt Strength	Spiral Belt Strength ^a		Temperature Range (continuous)		W Belt Weight		
			lb/ft	kg/m	lb	kg	°F	°C	lb/ft ²
Acetal	Acetal	1700	2530	375	170	-50 to 200	-46 to 93	1.85	9.03
Polypropylene	Acetal	1500	2232	300	136	34 to 200	1 to 93	1.26	6.15
SELM	Acetal	1060	1577	300	136	-50 to 200	-46 to 93	1.44	7.03

a. Published spiral belt strengths and their method of calculation vary among spiral belt manufacturers. Please consult an Intralox Spiral Engineer for accurate comparison of spiral belt strengths.

Spiralox® 2.7 Radius		
	in	mm
Pitch	2.00	50.8
Minimum Width ^a	24	610
Maximum Width	60	1524
Width Increments	0.50	12.7
Opening Size (approx.)	0.38 x 0.64	9.5 x 16.5
Open Area (fully extended)	48%	
Min. Open Area (2.7 TR)	23%	
Hinge Style	Open	
Drive Method	Hinge-Driven	
Product Notes		
<ul style="list-style-type: none"> • Contact Intralox for precise belt measurements and stock status before designing equipment or ordering a belt. • Designed for low-tension, capstan drive spiral applications with a minimum turn radius of 2.7 times the belt width (measured from inside edge). • The Intralox Spiral Program will help predict the strength requirements of most low-tension, capstan drive spiral applications, ensuring that the belt is strong enough for the application. Contact Intralox Technical Support for more information. • Lightweight, relatively strong belt with smooth surface grid. • Belt openings pass straight through the belt, making the belt easy to clean. • Uses headless rods. • Contact Customer Service for preferred run direction on spiral applications. <p>WARNING: Do not place fingers in or on this belt. Fingers can get trapped in belt openings, resulting in personal injury. This belt has pinch points due to the belt spreading and collapsing as it flexes to follow the conveyor path. Pinch points can trap fingers, hair, or clothing, causing personal injury. Do not wear loose clothing, loose gloves, or hand/finger jewelry when working near this belt. Call Customer Service for tags, flyers, and stickers containing this warning.</p>		
Additional Information		
<ul style="list-style-type: none"> • See "Belt Selection Process" (page 5) • See "Standard Belt Materials" (page 9) • See "Special Application Belt Materials" (page 9) • See "Friction Factors" (page 13) 		

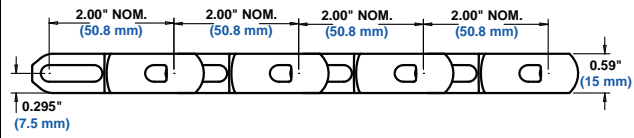
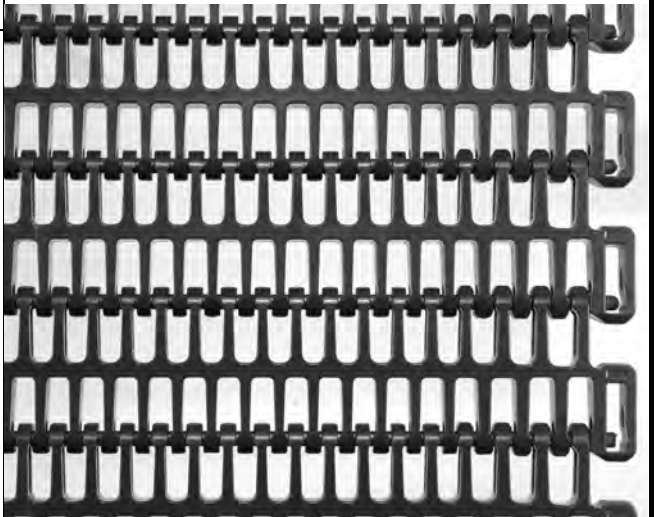
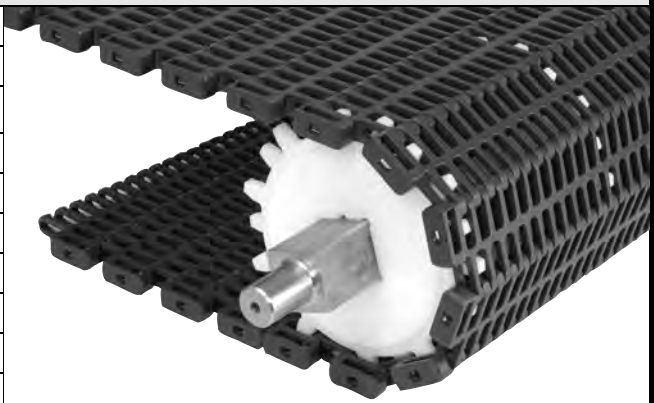

a. Contact Intralox Customer Service for more information regarding belt widths under 24 in (610 mm).

Belt Data										
Belt Material	Standard Rod Material Ø 0.24 in (6.1 mm)	BS	Straight Belt Strength	Spiral Belt Strength ^a		Temperature Range (continuous)		W Belt Weight		
				lb/ft	kg/m	lb	kg	°F	°C	lb/ft ²
Acetal	Acetal		1700	2530	375	170	-50 to 200	-46 to 93	1.86	9.08
Polypropylene	Acetal		1500	2232	300	136	34 to 200	1 to 93	1.26	6.15
SELM	Acetal		1060	1577	300	136	-50 to 200	-46 to 93	1.44	7.03

a. Published spiral belt strengths and their method of calculation vary among spiral belt manufacturers. Please consult an Intralox Spiral Engineer for accurate comparison of spiral belt strengths.

Side Drive		
	in	mm
Pitch	2.00	50.8
Minimum Width ^a	12	304.8
Maximum Width	60	1524
Width Increments	0.50	12.7
Opening Size (approx.)	0.38 x 0.64	9.5 x 16.5
Open Area (fully extended) ^b	44%	
Min. Open Area (2.0 TR)	23%	
Hinge Style	Open	
Drive Method	Hinge-Driven	
Product Notes		
<ul style="list-style-type: none"> • Contact Intralox for precise belt measurements and stock status before designing equipment or ordering a belt. • Rod insertion is accomplished from edge of belt. No special tools are required. • Uses headless rods. • Designed for standard drive and i-Drive systems. • Do not use in spiral conveyor systems. • Turn ratios of 2.0 times belt width (measured from inside edge). • Preferred run direction is to align slotted holes leading. • Consult Engineering Program/ i-Drive Program for specific widths not listed in this product data. <p>WARNING: Do not place fingers in or on this belt. Fingers can get trapped in belt openings, resulting in personal injury. This belt has pinch points due to the belt spreading and collapsing as it flexes to follow the conveyor path. Pinch points can trap fingers, hair, or clothing, causing personal injury. Do not wear loose clothing, loose gloves, or hand/finger jewelry when working near this belt. Call Customer Service for tags, flyers, and stickers containing this warning.</p>		
Additional Information		
<ul style="list-style-type: none"> • See “Belt Selection Process” (page 5) • See “Standard Belt Materials” (page 9) • See “Special Application Belt Materials” (page 9) • See “Friction Factors” (page 13) 		

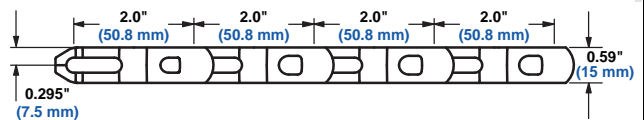
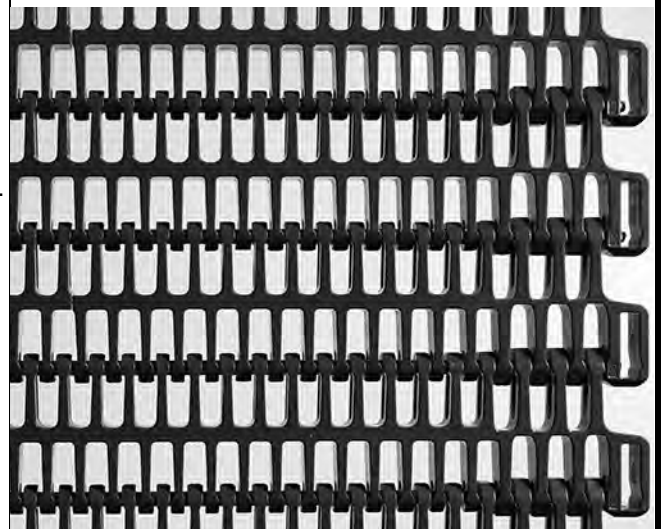
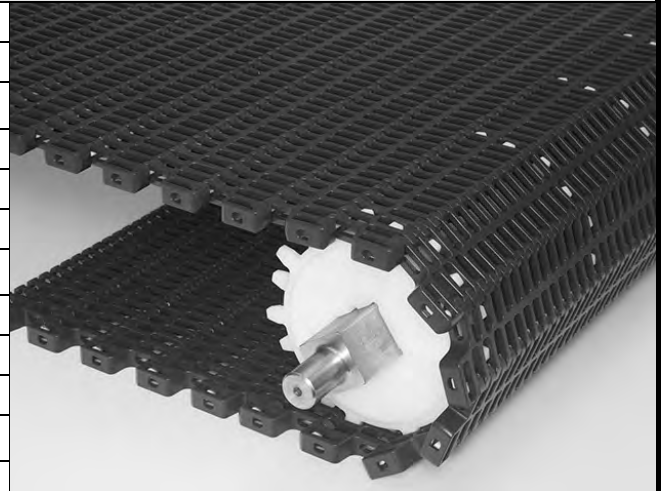

- a. Contact Intralox Customer Service for more information regarding belt widths under 12 in (305 mm).
 b. Open area calculations for S2700 Dual Turning (2.0) are unique to this style, and therefore are not directly comparable to other S2700 styles.

Belt Data										
Belt Material	Standard Rod Material Ø 0.240 in (6.1 mm)	BS	Straight Belt Strength	Curved Belt Strength ^a		Temperature Range (continuous) ^b		W Belt Weight		
				lb/ft	kg/m	lb	kg	°F	°C	lb/ft ²
Acetal	Acetal		1700	2530	375	170	-50 to 200	-46 to 93	1.84	8.98
Acetal	Nylon		1700	2530	375	170	-50 to 200	-46 to 93	1.81	8.84
SELM	Acetal		1060	1577	300	136	-50 to 200	-46 to 93	1.42	6.93
SELM	Nylon		1060	1577	300	136	-50 to 212	-46 to 100	1.40	6.84

- a. Published curved belt strengths and their method of calculation vary among spiral belt manufacturers. Please consult an Intralox Spiral Engineer for accurate comparison of curve belt strengths.
 b. Belt will function mechanically up to 240°F (116°C). Belt used in the temperature window of 212°F to 240°F (100°C to 116°C) is not FDA-compliant.

Sprocket and Support Quantity Reference^a

Belt Width Range ^b		Minimum Number of Sprockets Per Shaft ^c	Wearstrips ^d	
in.	mm		Carryway	Returnway
24	610	5	2	2
26	660	5	2	2
28	711	5	2	2
30	762	5	3	2
32	813	5	3	2
34	864	7	3	2
36	914	7	3	2
38	965	7	3	2
40	1016	7	3	2
42	1067	7	3	2
44	1118	7	3	2
46	1168	9	3	2
48	1219	9	3	2
50	1270	9	3	2
52	1321	9	3	2
54	1372	9	3	2
56	1422	9	4	3
58	1473	11	4	3
60	1524	11	4	3
For Other Widths, Use Odd Number of Sprockets at Maximum 8 in. (203 mm) \varnothing Spacing			Maximum 25 in. (635 mm) \varnothing Spacing	Maximum 30 in. (762 mm) \varnothing Spacing

- For low-tension capstan drive spirals contact Technical Support Group for suggested carryway support recommendations. Belt edges must be supported by support rollers on drive shafts. Contact Technical Support Group for more information.
- If your belt width exceeds a number listed in the table, please refer to the sprocket and support material minimums for the next larger width range listed. Belts are available in 0.50 in. (12.7 mm) increments beginning with minimum width of 24 in. (610 mm). **If the actual width is critical, consult Customer Service.**
- These are the minimum number of sprockets. Additional sprockets may be required for heavily loaded applications. See Retainer Rings/Center Sprocket Offset chart on page 410 for lock down location.
- Carryway Spacing dependant on a distributed 2 lb/ft² at 65 °F for Acetal belt with Acetal Rod with a 2" and 4" overhang.

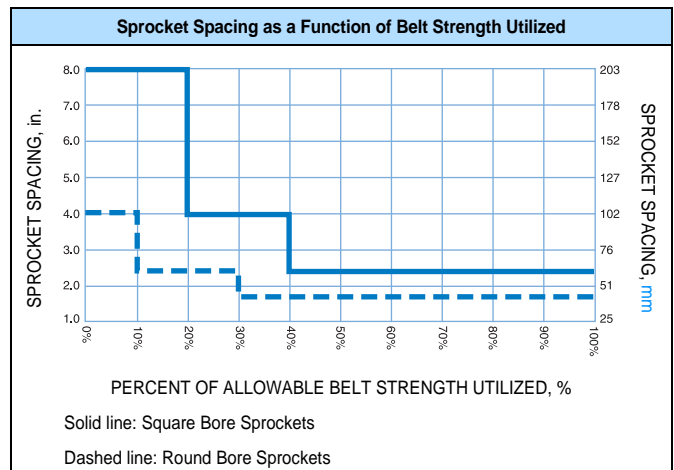
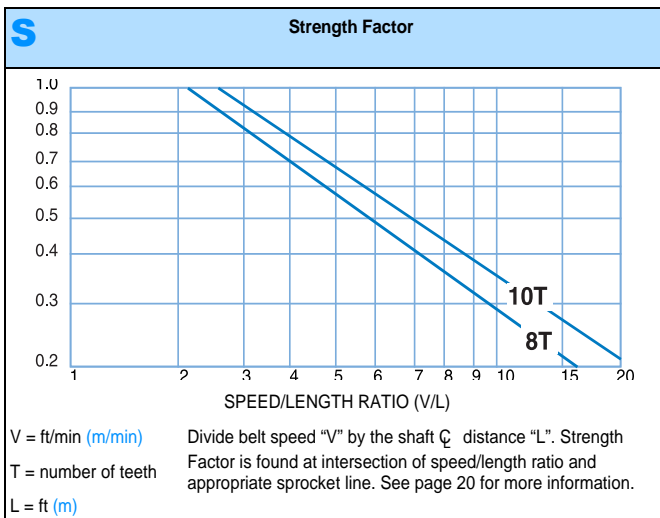

Acetal Sprocket ^a										
No. of Teeth (Chordal Action)	Nom. Pitch Dia. in	Nom. Pitch Dia. mm	Nom. Outer Dia. in	Nom. Outer Dia. mm	Nom. Hub Width in	Nom. Hub Width mm	Available Bore Sizes			
							U.S. Sizes		Metric Sizes	
							Round in	Square in	Round mm	Square mm
8 (7.61%)	5.2	132	5.4	136	0.8	20.32	1-1/4 1-7/16 2	1-1/2 2-1/2		60
10 (4.85%)	6.5	165	6.7	170	0.8	20.32	1-1/4 1-7/16 2	1-1/2 2-1/2		40 60

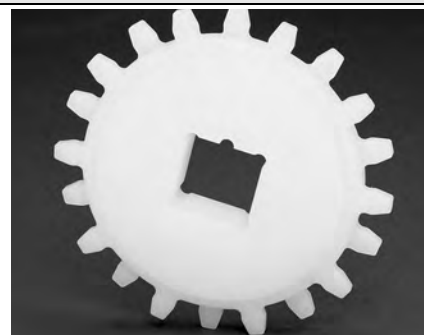

a. Contact Customer Service for lead times, preferred method of locking down sprockets, and for proper sprocket timing.

Support Wheel					
Available Pitch Diameter		Available Bore Sizes			
in	mm	U.S. Sizes		Metric Sizes	
		Round in	Square in	Round mm	Square mm
5.2	132	1.25 1-7/16 1.5 2	1.5 2.5		40 60
6.5	165	1.25 1-7/16 1.5 2	1.5 2.5		40 60

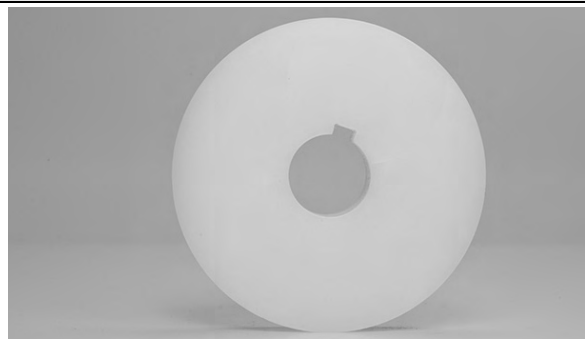

Overlapping Sideguards		
Available Height		Available Materials
in	mm	
0.50	12.7	Acetal, SELM
1.00	25.4	

Note: Sideguards maximize product carrying capacity: they fit into the very edge of the belt, with no indent.

Note: Sideguard assembly does not require "finger cuts" on the modules, so the belt's beam strength is uncompromised.

Note: Turn ratio for 0.50 in (12.7 mm) Overlapping Sideguards in Acetal is 1.6.

Note: The turn ratio for 1.00 in (25.4 mm) Overlapping Sideguard is 1.6 only.



Universal Sideguards		
Available Height		Available Materials
in	mm	
0.50	12.7	Acetal, SELM
1.00	25.4	
2.00 ^a	50.8 ^a	

Note: Maximizes product carrying capacity: they fit into the very edge of the belt, with no indent.

Note: Assembly does not require "finger cuts" on the modules, so the belt's beam strength is uncompromised.



a. Only available in 1.6 TR

Lane Dividers		
Available Height		Available Materials
in	mm.	
0.75	19	Acetal, SELM



Conveyor Frame Dimensions

Regardless of type or configuration, all conveyors using Intralox belts have some basic dimensional requirements. Specifically, dimensions “A”, “B”, “C” and “E” listed below should be implemented in any design.

For general applications and applications where end transfer of tip-sensitive product is not critical, use the “A” dimension at the bottom of the range.

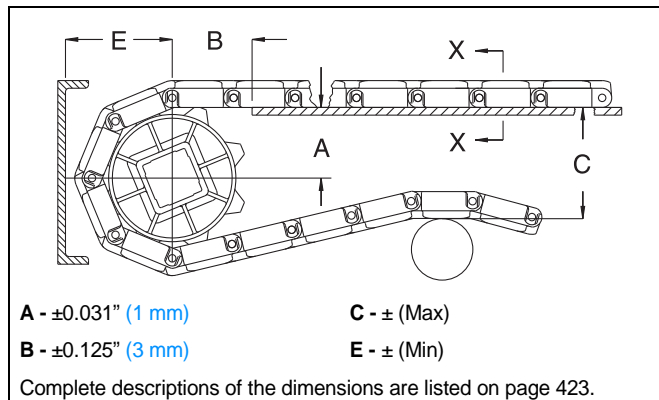

Sprocket Description					A		B		C		E	
Pitch Diameter		Nominal OD		No. Teeth	Range (Bottom to Top)		in.	mm	in.	mm	in.	mm
in.	mm	in.	mm		in.	mm						
SERIES 2700 SPIRALOX® 1.6 RADIUS, 2.2 RADIUS, 2.7 RADIUS												
5.2	132	5.4	137	8	2.12-2.32	54-59	2.25	57	5.23	133	2.97	75
6.5	165	6.7	170	10	2.78-2.94	71-75	2.54	65	6.47	164	3.59	91

Dead Plate Gap

Where there is a transfer point from a belt without finger transfer plates to a dead plate, there should be a gap between the surfaces to allow for the chordal action of the belt. As the belt engages its sprockets, chordal action causes the modules to move past a *fixed* point (the tip of the dead plate) with *varying* clearances. The table below shows the minimum amount of gap which occurs at the “low point” of the modules if the tip of the dead plate just comes in contact with the “high point” as the modules pass.

In some installations it may be desirable to keep the tip of the dead plate in contact with the belt, rather than allow a gap to occur. This can be done by hinging the mounting bracket for the dead plate. This allows the dead plate to move as the modules pass, but results in a small oscillating motion which may present tipping problems for sensitive containers or products.

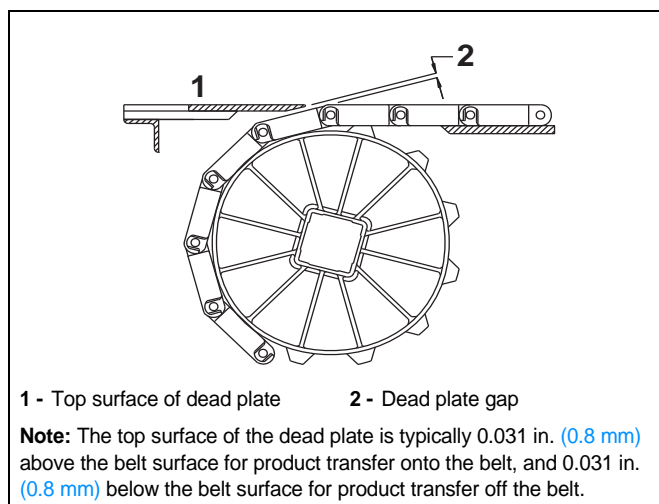

Sprocket Description				Gap	
Pitch Diameter		No. Teeth	in.	mm	
in.	mm				
5.2	132	8	0.200	5.1	
6.5	165	10	0.158	4.0	

HOLD DOWN RAILS AND WEARSTRIPS

Intralox recommends using continuous hold down rails through an entire turn, starting at a distance of 1X the belt width before the turn and ending 1X the belt width after the

turn. This applies to both carryway and returnway. The use of hold down rails along both side of the belt over the full carryway is recommended but not mandatory. See “*Custom wearstrips*” (page 416).

FLUSH EDGE WITH WEARSTRIP

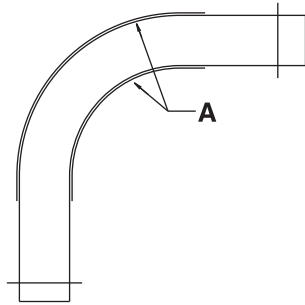

A - HOLD DOWN RAIL PLACEMENT

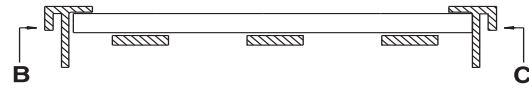

B - OUTSIDE HOLD DOWN RAIL

C - INSIDE HOLD DOWN RAIL

Fig. 2-10 HOLD DOWN RAILS AND WEARSTRIPS FOR SERIES 2700 FLAT-TURNS

BELT SELECTION INSTRUCTIONS

ENGINEERING PROGRAM ANALYSIS FOR SERIES 2700

Intralox Customer Service Technical Support Group can calculate the estimated belt pull for radius applications using **Series 2700**. The following information is required (refer to “*Radius belt data sheet*” (page 469)):

- Any environmental conditions which may affect the friction coefficient (for dirty or abrasive conditions, use higher friction coefficients than normal)
- Belt width
- Length of each straight run
- Turning angle of each turn

- Turn direction of each turn
- Inside turning radius of each turn
- Carryway/hold down rail material
- Product loading lb/ft² (kg/m²)
- Product back-up conditions
- Belt speed
- Elevation changes on each section
- Operating temperatures.

For assistance with radius belt and low-tension capstan drive spiral selections, contact Intralox Customer Service Technical Support Group. The Engineering Program should be run to ensure that the belt is strong enough for the radius application in question.

SERIES 2700 DESIGN GUIDE SUMMARY

For more information, see the *Installation, Maintenance and Troubleshooting manual* available from Intralox.

- A** - The minimum turning radius for **Series 2700** is 2.2 times the belt width, measured from the inside edge for the standard edge or 1.7 times the belt width for the tight turning style.
- B** - The minimum straight run required between turns of opposing direction is 2.0 times the belt width. Shorter straight sections will lead to high wear on the edge guide rail and high pull stresses in the belt.
- C** - There is no minimum straight run required between turns that are in the same direction.
- D** - The minimum final straight run (leading to the drive shaft) should be a minimum of 5 ft. (1.5 m). If 5 ft. (1.5 m) is not feasible, a shorter distance (down to 1.5 times the belt width) would require a weighted take up in order to avoid sprocket wear and tracking problems. See "Special Take-Up Arrangements" (page 431).
- E** - The minimum length of the first straight run (immediately after the idle shaft) is 1.5 times the belt width. When shorter lengths are required (down to 1.0 times the width), an idle roller may be used in place of sprockets.
- F** - IDLE SHAFT
- G** - 1ST TURN
- H** - BELT WIDTH
- I** - BELT TRAVEL
- J** - 2ND TURN
- K** - DRIVE MOTOR
- L** - DRIVE SHAFT

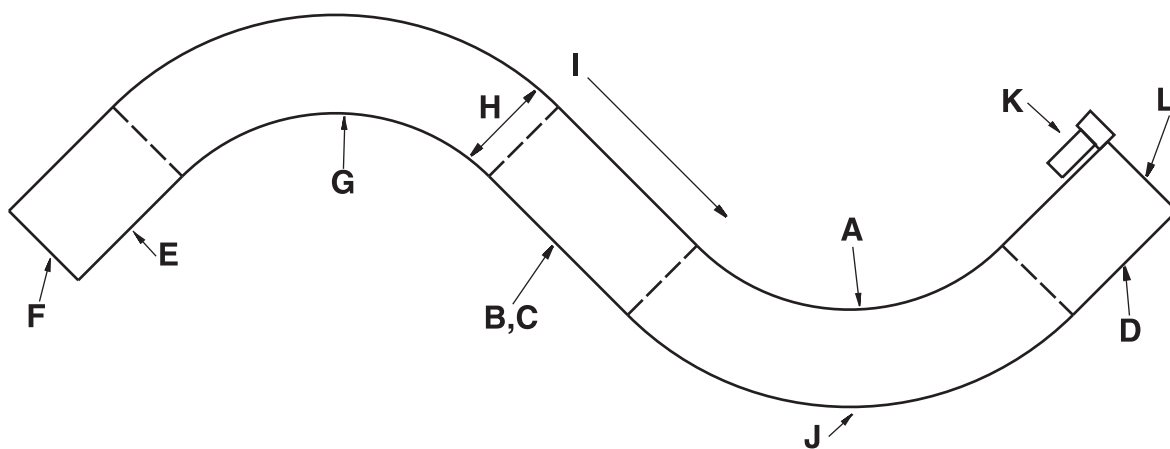

Fig. 2-11 TYPICAL 2-TURN RADIUS LAYOUT

Spiralox® GTech 1.6 Radius		
	in	mm
Pitch	1.5	38.1
Minimum Width	24	609.6
Width Increments	1.00	25.4
Opening Sizes (approx.)	1.1 x 0.42	27.9 x 10.7
Open Area (Fully Extended)	50%	
Minimum Open Area	36%	
Hinge Style	Open	
Drive Method	Hinge-Driven	

Product Notes

- **Contact Intralox for precise belt measurements and stock status before designing equipment or ordering a belt.**
- Designed for low-tension capstan drive spiral applications with a minimum turn radius of 1.6 times the belt width (measured from the inside edge).
- The Intralox Spiral Program will help predict the strength requirements of most low-tension, capstan drive spiral applications, ensuring that the belt is strong enough for the application. Contact Intralox Technical Support for more information.
- Minimum sprocket indent from the inside belt edge and from the outside belt edge may vary. Contact Customer Service to determine exact placement.
- Lightweight, relatively strong belt with smooth surface grid.
- Relatively uniform open area across the width of the belt to aid in freezing and cooling product.
- Belt openings pass straight through the belt, making the belt easy to clean.
- Uses headless rods.
- Robust edge feature adds strength to the outside edge of the belt.

WARNING: Do not place fingers in or on this belt. Fingers can get trapped in belt openings, resulting in personal injury. This belt has pinch points due to the belt spreading and collapsing as it flexes to follow the conveyor path. Pinch points can trap fingers, hair, or clothing, causing personal injury. Do not wear loose clothing, loose gloves, or hand/finger jewelry when working near this belt. Call Customer Service for tags, flyers, and stickers containing this warning.

Additional Information

- See “Belt Selection Process” (page 5)
- See “Standard Belt Materials” (page 9)
- See “Special Application Belt Materials” (page 9)
- See “Friction Factors” (page 13)

The diagram shows a cross-section of the spiral belt with a pitch of 1.5" (38.1 mm) and a total width of 0.59" (14.9 mm). The height of the mesh openings is 0.295" (7.45 mm).

Belt Data									
Belt Material	Standard Rod Material Ø 0.240 in (6.1 mm)	BS Straight Belt Strength		Spiral Belt Strength ^a		Temperature Range (continuous)		W Belt Weight	
		lb./ft.	kg/m	lbs.	kg	°F	°C	lb./ft. ²	kg/m ²
Acetal	Acetal	1600	2381	475	215	-50 to 200	-46 to 93	1.60	7.81
SELM	Acetal	500	744	375	170	-50 to 200	-46 to 93	1.28	6.25

a. Published spiral belt strengths and their method of calculation vary among spiral manufacturers. Please contact Intralox Customer Service for accurate comparison of spiral belt strengths.

Spiralox® GTech Rounded Friction Top

	in	mm
Pitch	1.5	38.1
Minimum Width	24	609.6
Width Increments	1.00	25.4
Opening Sizes (approx.)	1.1 x 0.42	27.9 x 10.7
Hinge Style	Open	
Drive Method	Hinge-Driven	

Product Notes

- Contact Intralox for precise belt measurements and stock status before designing equipment or ordering a belt.
- The Intralox Spiral Program will help predict the strength requirements of most low-tension, capstan drive spiral applications, ensuring that the belt is strong enough for the application. Contact Intralox Technical Support for more information.
- Friction top available in white polypropylene with white rubber or blue polypropylene with high-performance blue rubber.
- Contact Customer Service for minimum indent requirements.
- Minimum sprocket indent from the inside belt edge and from the outside belt edge may vary. Contact Customer Service to determine exact placement.
- Must have a 2.0 in (50.8 mm) minimum gap between friction inserts for correct sprocket placement.
- Lightweight, relatively strong belt with smooth surface grid.
- Belt openings pass straight through the belt, making the belt easy to clean.
- Uses headless rods.
- Robust edge feature adds strength to the outside edge of the belt.

WARNING: Do not place fingers in or on this belt. Fingers can get trapped in belt openings, resulting in personal injury. This belt has pinch points due to the belt spreading and collapsing as it flexes to follow the conveyor path. Pinch points can trap fingers, hair, or clothing, causing personal injury. Do not wear loose clothing, loose gloves, or hand/finger jewelry when working near this belt. Call Customer Service for tags, flyers, and stickers containing this warning.

Additional Information

- See "Belt Selection Process" (page 5)
- See "Standard Belt Materials" (page 9)
- See "Special Application Belt Materials" (page 9)
- See "Friction Factors" (page 13)

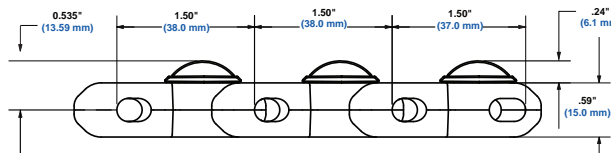
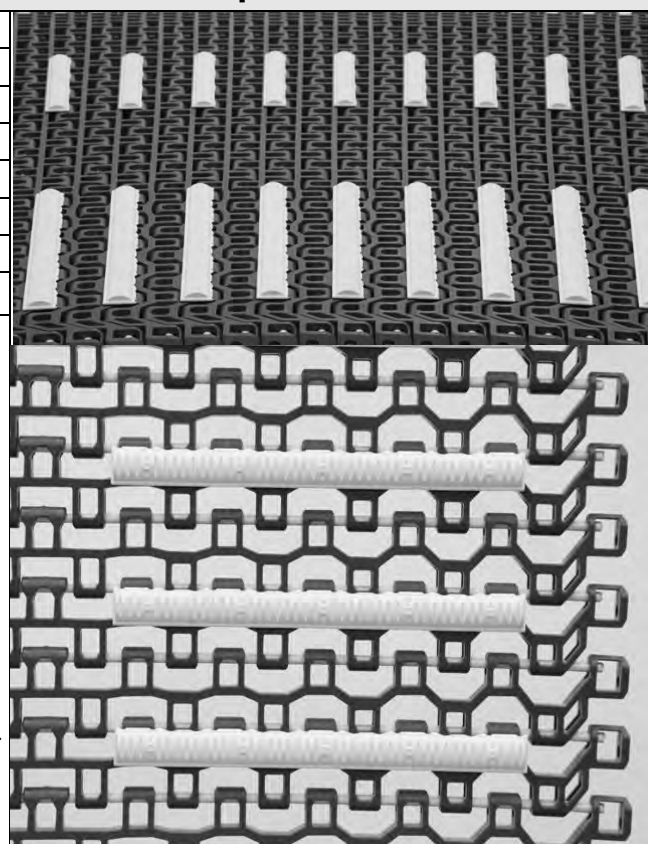

Belt Data

Base Belt Material	Base/Friction Color	Standard Rod Material Ø 0.24 in (6.1 mm)	BS Belt Strength		Spiral Belt Strength ^a		Temperature Range (continuous)		W Belt Weight		Friction Top Hardness	Agency Acceptability ^b	
			lb/ft	kg/m	lb	kg	°F	°C	lb/ft ²	kg/m ²		FDA (USA)	EU MC ^c
Acetal	White/White	Acetal	1700	2530	376 (475)	171 (215)	34 to 150	1 to 66	1.44 (1.54)	7.03 (7.52)	55 Shore A	•	•
Acetal	High Performance FT Blue/Blue	Acetal	1700	2530	376 (475)	171 (215)	34 to 212	1 to 100	1.44 (1.54)	7.03 (7.52)	59 Shore A	•	•

- Published spiral belt strengths and their method of calculation vary among spiral manufacturers. Contact an Intralox Spiral Engineer for accurate comparison of spiral belt strengths.
- Prior to Intralox's development of Series S2800, USDA-FSIS Meat and Poultry discontinued publishing a list of acceptable new products designed for food contact. As of the printing of the manual, third-party approvals are being investigated, but are not yet sanctioned by the USDA-FSIS.
- European Migration Certificate providing approval for food contact according to EU Regulation 10/2011.

Spiralox® GTech 2.2 and 3.2

	in	mm
Pitch	1.5	38.1
Minimum Width	24	609.6
Width Increments	1.00	25.4
Opening Sizes (approx.)	1.1 x 0.42	27.9 x 10.7
Open Area (Fully Extended)	50%	
Minimum Open Area	36%	
Hinge Style	Open	
Drive Method	Hinge-Driven	



Product Notes

- **Contact Intralox for precise belt measurements and stock status before designing equipment or ordering a belt.**
- Designed for low-tension capstan drive spiral applications with a minimum turn radius of 2.2 times the belt width (measured from the inside edge).
- The Intralox Spiral Program will help predict the strength requirements of most low-tension, capstan drive spiral applications, ensuring that the belt is strong enough for the application. Contact Intralox Technical Support for more information.
- Minimum sprocket indent from the inside belt edge and from the outside belt edge may vary. Contact Customer Service to determine exact placement.
- Lightweight belt with extreme beam strength prevents bowing and buckling.
- Relatively uniform open area across the width of the belt to aid in freezing and cooling product.
- Open hinge and slot design facilitates sanitation.
- Uses headless rods.
- Robust edge feature adds strength to the outside edge of the belt.

WARNING: Do not place fingers in or on this belt. Fingers can get trapped in belt openings, resulting in personal injury. This belt has pinch points due to the belt spreading and collapsing as it flexes to follow the conveyor path. Pinch points can trap fingers, hair, or clothing, causing personal injury. Do not wear loose clothing, loose gloves, or hand/finger jewelry when working near this belt. Call Customer Service for tags, flyers, and stickers containing this warning.

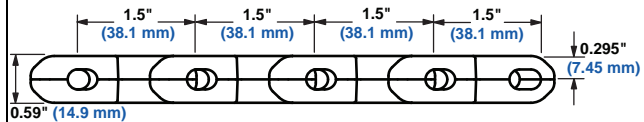
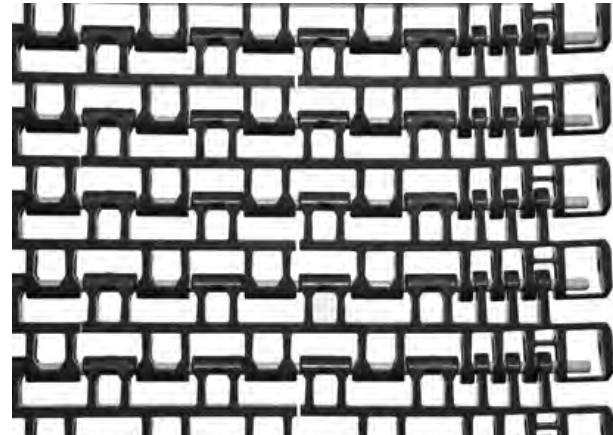

Additional Information

- See "Belt Selection Process" (page 5)
- See "Standard Belt Materials" (page 9)
- See "Special Application Belt Materials" (page 9)
- See "Friction Factors" (page 13)

Belt Data

Belt Material	Standard Rod Material Ø 0.240 in (6.1 mm)	BS Straight Belt Strength	Spiral Belt Strength ^a		Temperature Range (continuous)		W Belt Weight		
			lb./ft.	kg/m	lbs.	kg	°F	°C	lb./ft. ²
Acetal	Acetal	1600	2381	475	215	-50 to 200	-46 to 93	1.60	7.81
SELM	Acetal	500	744	375	170	-50 to 200	-46 to 93	1.27	6.3

a. Published spiral belt strengths and their method of calculation vary among spiral manufacturers. Please consult an Intralox Spiral Engineer for accurate comparison of spiral belt strengths.

Spiralox® DirectDrive™ (DD)

	in	mm
Pitch	1.5	38.1
Minimum Width	24	609.6
Width Increments	1.00	25.4
Opening Sizes (approx.)	1.1 x 0.42	27.9 x 10.7
Open Area (Fully Extended)	50%	
Minimum Open Area	36%	
Hinge Style	Open	
Drive Method	Hinge-Driven	

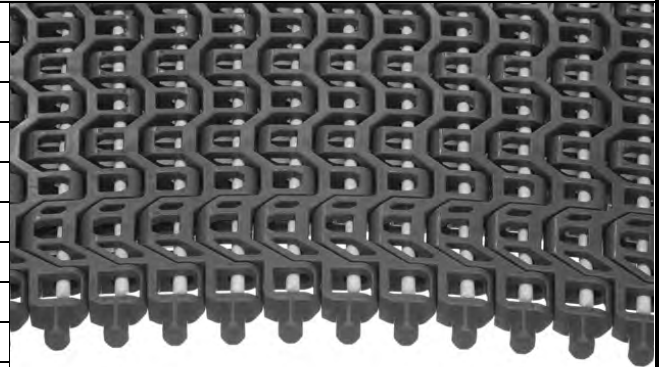

Product Notes

- **Contact Intralox for precise belt measurements and stock status before designing equipment or ordering a belt.**
- The Intralox Spiral Program will help predict the strength requirements of most spiral applications, ensuring that the belt is strong enough for the application.
- Minimum sprocket indent from the inside belt edge and from the outside belt edge may vary. Contact Customer Service to determine exact placement.
- Lightweight, relatively strong belt with smooth surface grid.
- Relatively uniform open area across the width of the belt to aid in freezing and cooling product.
- Belt openings pass straight through the belt, making the belt easy to clean.
- Uses headless rods.
- Robust edge feature adds strength to the outside edge of the belt.

WARNING: Do not place fingers in or on this belt. Fingers can get trapped in belt openings, resulting in personal injury. This belt has pinch points due to the belt spreading and collapsing as it flexes to follow the conveyor path. Pinch points can trap fingers, hair, or clothing, causing personal injury. Do not wear loose clothing, loose gloves, or hand/finger jewelry when working near this belt. Call Customer Service for tags, flyers, and stickers containing this warning.

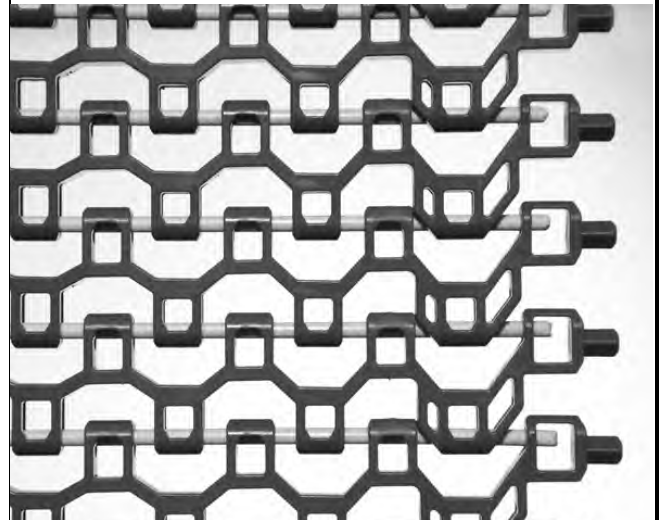

Additional Information

- See "Belt Selection Process" (page 5)
- See "Standard Belt Materials" (page 9)
- See "Special Application Belt Materials" (page 9)
- See "Friction Factors" (page 13)

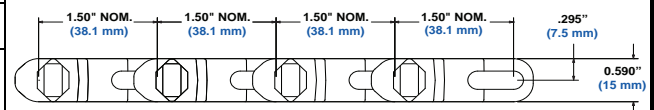

Belt Data

Belt Material	Standard Rod Material Ø 0.240 in (6.1 mm)	BS Straight Belt Strength		Spiral Belt Strength ^a		Temperature Range (continuous)		W Belt Weight	
		lb./ft.	kg/m	lbs.	kg	°F	°C	lb./ft. ²	kg/m ²
Acetal	Acetal	1600	2381	475	215	-50 to 200	-46 to 93	1.60	7.81
SELM	Acetal	500	744	375	170	-50 to 200	-46 to 93	1.27	6.2

a. Published spiral belt strengths and their method of calculation vary among spiral manufacturers. Please consult an Intralox Spiral Engineer for accurate comparison of spiral belt strengths.

Sprocket and Support Quantity Reference				
Belt Width Range ^a		Minimum Number of Sprockets Per Shaft ^b	Wearstrips	
in.	mm		Carryway	Returnway
24	610	4	2	2
26	660	4	2	2
28	711	5	2	2
30	762	5	2	2
32	813	5	2	2
34	864	6	2	2
36	914	6	2	2
38	965	6	3	3
40	1016	7	3	3
42	1067	7	3	3
44	1118	7	3	3
46	1168	8	3	3
48	1219	8	3	3
50	1270	8	3	3
52	1321	9	3	3
54	1372	9	3	3
56	1422	9	3	3
58	1473	10	3	3
60	1524	10	3	3

- a. If your belt width exceeds a number listed in the table, please refer to the sprocket and support material minimums for the next larger width range listed. Belts are available in 1.00 in. (25.4 mm) increments beginning with minimum width of 24 in. (609.6 mm). If the actual width is critical, consult Customer Service.
- b. These are the minimum number of sprockets. Additional sprockets may be required for heavily loaded applications.

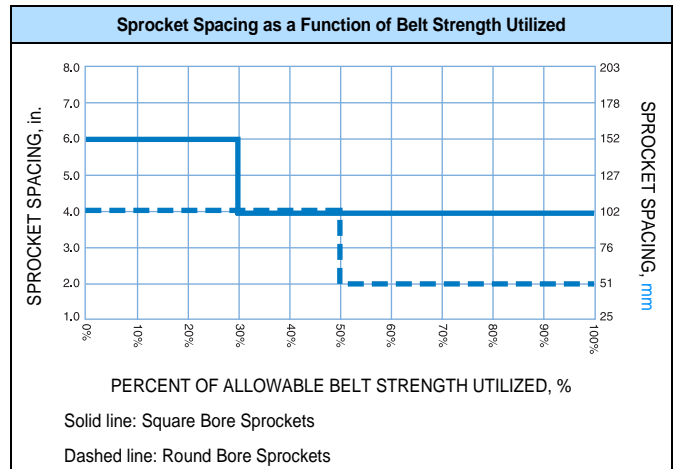
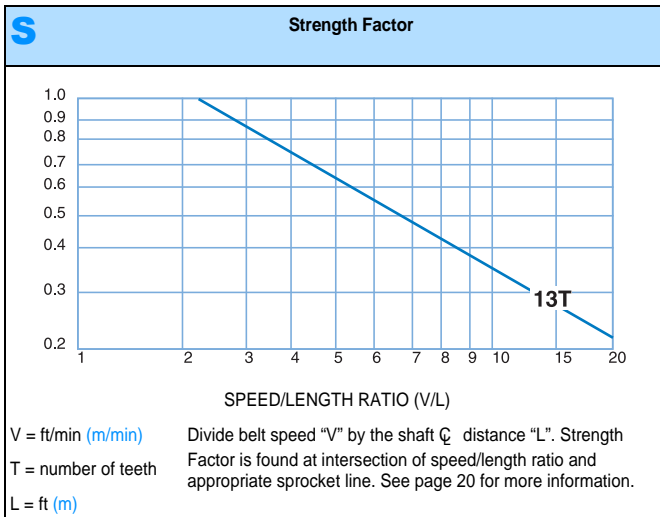

Acetal Sprocket ^a										
No. of Teeth (Chordal Action)	Nom. Pitch Dia. in	Nom. Pitch Dia. mm	Nom. Outer Dia. in	Nom. Outer Dia. mm	Nom. Hub Width in	Nom. Hub Width mm	Available Bore Sizes			
							U.S. Sizes		Metric Sizes	
							Round in	Square in	Round mm	Square mm
13 (1.92%)	6.2	157.5	6.4	162.6	1.2	30.5	1-7/16 1-1/2 2	1.5 2.5		40 60



a. Contact Customer Service for lead times.

Support Wheel

Available Pitch Diameter		Available Bore Sizes			
in	mm	U.S. Sizes		Metric Sizes	
		Round in	Square in	Round mm	Square mm
6.3	160	1-7/16	1.5		40
		2	2.5		60

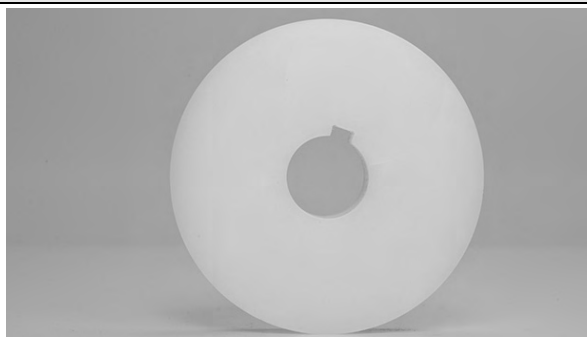

Overlapping Sideguards

Available Height		Available Materials
in	mm	
0.50	12.7	Acetal
1.0	25.4	Acetal

Note: Maximizes product carrying capacity: they fit into the very edge of the belt, with no indent.

Note: Assembly does not require "finger cuts" on the modules, so the belt's beam strength is uncompromised.

Note: Turn ratio for 0.50 in (12.7 mm) Overlapping Sideguards is 1.6.

Note: Makes the belt's outer edge more snag-resistant.

Note: Keeps small products from falling through belt gaps.



Lane Dividers

Available Height		Available Materials
in	mm	
0.75	19	Acetal, SELM

Note: Assembly does not require "finger cuts" on the modules, so the belt's beam strength is uncompromised.

Note: Lane Dividers can be spaced 2 in (50.8 mm) apart along the width of the belt.

Note: Please contact Customer Service for minimum indent requirements.



Conveyor Frame Dimensions

Regardless of type or configuration, all conveyors using Intralox belts have some basic dimensional requirements. Specifically, dimensions “A”, “B”, “C” and “E” listed below should be implemented in any design.

For general applications and applications where end transfer of tip-sensitive product is not critical, use the “A” dimension at the bottom of the range.

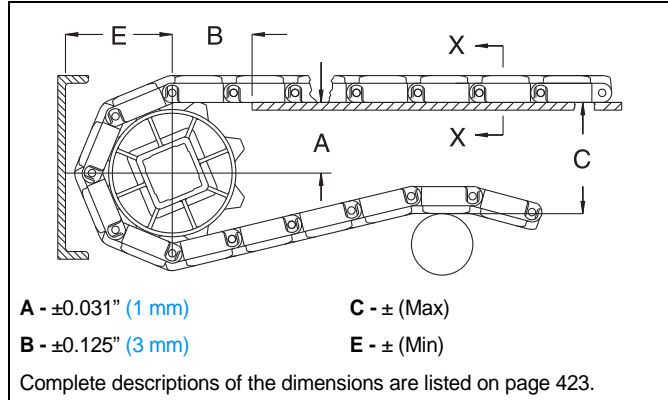

Sprocket Description					A		B		C		E	
Pitch Diameter		Nominal OD		No. Teeth	Range (Bottom to Top)		in.	mm	in.	mm	in.	mm
in.	mm	in.	mm		in.	mm						
SERIES 2800 SPIRALOX® G-TECH 1.6, 2.2 & 3.2 RADIUS and DIRECT DRIVE												
6.3	160	6.5	165	13	2.75-2.84	70-72	2.51	64	6.27	159	3.49	89
SERIES 2800 SPIRALOX® G-TECH ROUNDED FRICTION TOP												
6.3	160	6.5	165	13	2.75-2.84	70-72	2.51	64	6.51	165	3.74	95

Dead Plate Gap

Where there is a transfer point from a belt without finger transfer plates to a dead plate, there should be a gap between the surfaces to allow for the chordal action of the belt. As the belt engages its sprockets, chordal action causes the modules to move past a *fixed* point (the tip of the dead plate) with *varying* clearances. The table below shows the minimum amount of gap which occurs at the “low point” of the modules if the tip of the dead plate just comes in contact with the “high point” as the modules pass.

In some installations it may be desirable to keep the tip of the dead plate in contact with the belt, rather than allow a gap to occur. This can be done by hinging the mounting bracket for the dead plate. This allows the dead plate to move as the modules pass, but results in a small oscillating motion which may present tippage problems for sensitive containers or products.

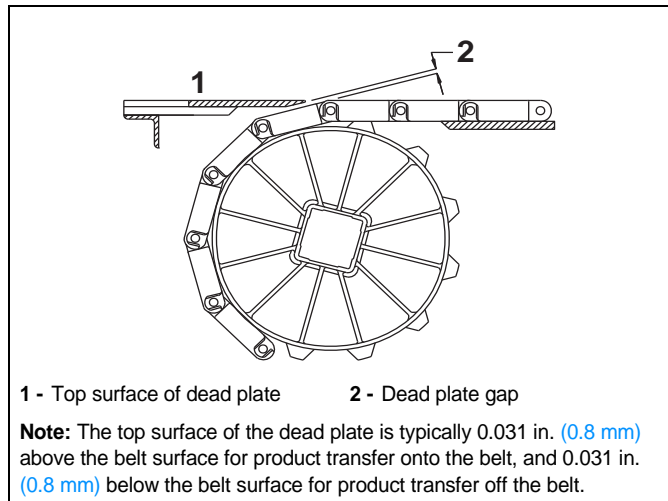

Sprocket Description				Gap		
Pitch Diameter		No. Teeth	in.	mm	in.	mm
in.	mm					
6.3	160	13	0.091	2.3		

HOLD DOWN RAILS AND WEARSTRIPS

Intralox recommends using continuous hold down rails through an entire turn, starting at a distance of 1X the belt width before the turn and ending 1X the belt width after the

turn. This applies to both carryway and returnway. The use of hold down rails along both side of the belt over the full carryway is recommended but not mandatory. See “*Custom wearstrips*” (page 416).

FLUSH EDGE WITH WEARSTRIP

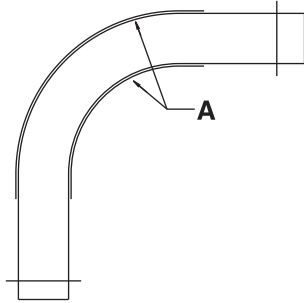

A - HOLD DOWN RAIL PLACEMENT

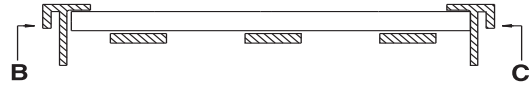

B - OUTSIDE HOLD DOWN RAIL

C - INSIDE HOLD DOWN RAIL

Fig. 2-12 HOLD DOWN RAILS AND WEARSTRIPS FOR SERIES 2800 FLAT-TURNS

BELT SELECTION INSTRUCTIONS

ENGINEERING PROGRAM ANALYSIS FOR SERIES 2800

Intralox Customer Service Technical Support Group can calculate the estimated belt pull for radius applications using **Series 2800**. The following information is required (refer to “*Radius belt data sheet*” (page 469)):

- Any environmental conditions which may affect the friction coefficient (for dirty or abrasive conditions, use higher friction coefficients than normal)
- Belt width
- Length of each straight run
- Turning angle of each turn

- Turn direction of each turn
- Inside turning radius of each turn
- Carryway/hold down rail material
- Product loading lb/ft² (kg/m²)
- Product back-up conditions
- Belt speed
- Elevation changes on each section
- Operating temperatures.

For assistance with radius belt and low-tension capstan drive spiral selections, contact Intralox Customer Service Technical Support Group. The Engineering Program should be run to ensure that the belt is strong enough for the radius application in question.

SERIES 2800 DESIGN GUIDE SUMMARY

For more information, see the **Installation, Maintenance and Troubleshooting manual** available from Intralox.

A - The minimum turning radius for **Series 2800** is 1.6 times the belt width, measured from the inside edge for the standard edge.

B - The minimum straight run required between turns of opposing direction is 1.6 times the belt width. Shorter straight sections will lead to high wear on the edge guide rail and high pull stresses in the belt.

C - There is no minimum straight run required between turns that are in the same direction.

D - The minimum final straight run (leading to the drive shaft) should be a minimum of 5 ft. (1.5 m). If 5 ft. (1.5 m) is not feasible, a shorter distance (down to 1.5 times belt width) would require a weighted take up in order to avoid sprocket wear and tracking problems. See "Special Take-Up Arrangements" (page 431).

E - The minimum length of the first straight run (immediately after the idle shaft) is 1.5 times the belt width. When shorter lengths are required (down to 1.0 times the width), an idle roller may be used in place of sprockets.

F - IDLE SHAFT

G - 1ST TURN

H - BELT WIDTH

I - BELT TRAVEL

J - 2ND TURN

K - DRIVE MOTOR

L - DRIVE SHAFT

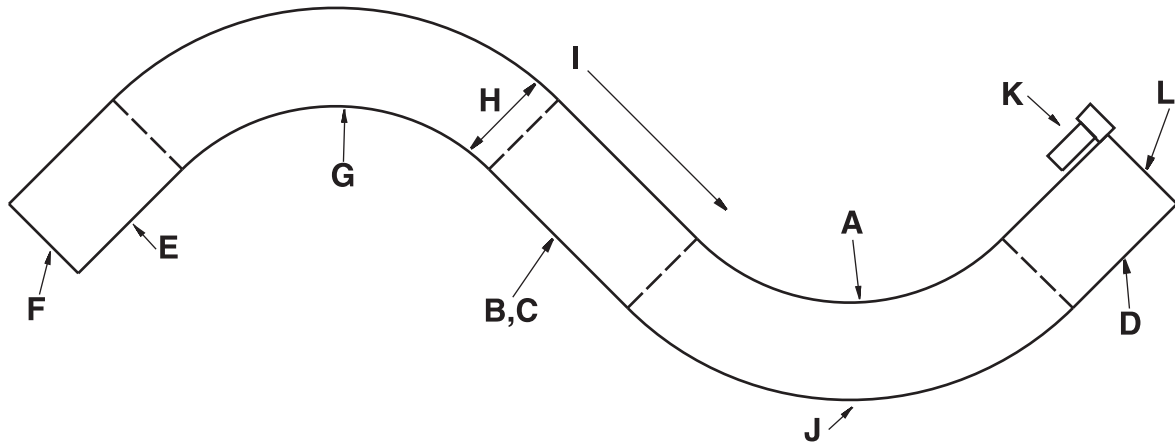
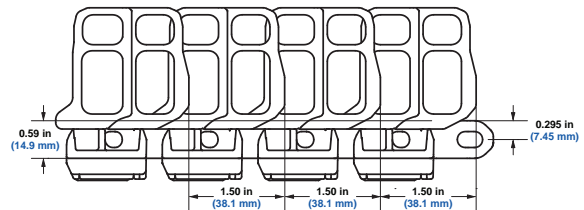
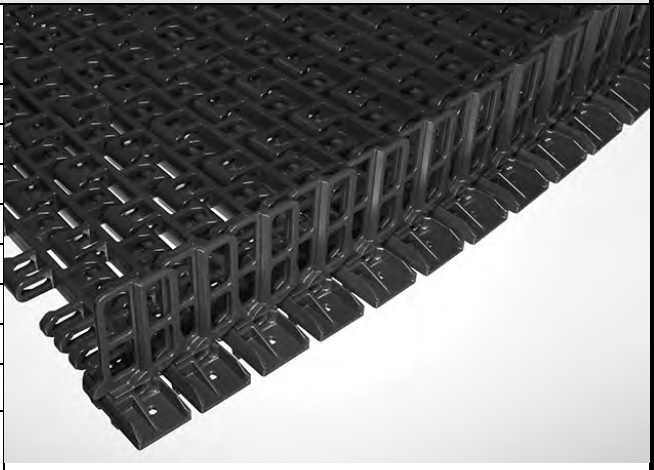

Fig. 2-13 TYPICAL 2-TURN RADIUS LAYOUT

DirectDrive™ Stacker		
	in	mm
Pitch	1.5	38.1
Minimum Width	12	304.8
Width Increments	2.00	50.8
Opening Sizes (approx.)	1.1 x 0.42	27.9 x 10.7
Open Area (Fully Extended)	50%	
Minimum Open Area	36%	
Hinge Style	Open	
Drive Method	Hinge-Driven	
Product Notes		
<ul style="list-style-type: none"> • Contact Intralox for precise belt measurements and stock status before designing equipment or ordering a belt. • Designed for stacker applications using the patented DirectDrive technology. • The Intralox Spiral Program can help predict the strength requirements of most spiral applications, ensuring the belt is strong enough for the application. Contact our Technical Service Group for more information. • Lightweight, strong belt with smooth surface grid for good product release. • Relatively uniform open area across the width of the belt to aid in freezing and cooling of product. • Belt openings pass straight through the belt, making the belt easy to clean. • 60 mm, 80 mm, & 100 mm tier spacing available. • Sideplates are permanently installed and cannot be replaced. • Uses headless rods. <p>WARNING: Do not place fingers in or on this belt. Fingers can get trapped in belt openings, resulting in personal injury. This belt has pinch points due to the belt spreading and collapsing as it flexes to follow the conveyor path. Pinch points can trap fingers, hair, or clothing, causing personal injury. Do not wear loose clothing, loose gloves, or hand/finger jewelry when working near this belt. Call Customer Service for tags, flyers, and stickers containing this warning.</p>		
Additional Information		
<ul style="list-style-type: none"> • See “Belt Selection Process” (page 5) • See “Standard Belt Materials” (page 9) • See “Special Application Belt Materials” (page 9) • See “Friction Factors” (page 13) 		



Belt Data									
Belt Material	Standard Rod Material Ø 0.240 in (6.1 mm)	BS Straight Belt Strength	Spiral Belt Strength ^a		Temperature Range (continuous) ^b		W Belt Weight		
			lb./ft	kg/m	lbs.	kg	°F	°C	lb./ft. ²
Acetal	Acetal	1600	2381	475	215	-50 to 200	-46 to 93	1.96	9.57

a. Published spiral belt strengths and their method of calculation vary among spiral manufacturers. Please consult an Intralox Spiral Engineer for accurate comparison of spiral belt strengths.
 b. Sideflexing applications should not exceed 180 °F (82 °C).

Sprocket and Support Quantity Reference				
Belt Width Range ^a		Minimum Number of Sprockets Per Shaft ^b	Wearstrips	
in	mm		Carryway	Returnway
24	610	4	2	2
26	660	4	2	2
28	711	5	2	2
30	762	5	2	2
32	813	5	2	2
34	864	6	2	2
36	914	6	2	2
38	965	6	3	3
40	1016	7	3	3
42	1067	7	3	3
44	1118	7	3	3
46	1168	8	3	3
48	1219	8	3	3
50	1270	8	3	3
52	1321	9	3	3
54	1372	9	3	3
56	1422	9	3	3
58	1473	10	3	3
60	1524	10	3	3

- a. If your belt width exceeds a number listed in the table, please refer to the sprocket and support material minimums for the next larger width range listed. Belts are available in 1.00 in. (25.4 mm) increments beginning with minimum width of 24 in. (609.6 mm). **If the actual width is critical, consult Customer Service.**
- b. These are the minimum number of sprockets. Additional sprockets may be required for heavily loaded applications. The center sprocket should be locked down. See Center Sprocket Offset chart for lock down location

Center Sprocket Offset		
Number of Links	Offset	
	in	mm
even	0.0	0.0
odd	0.5	12.7

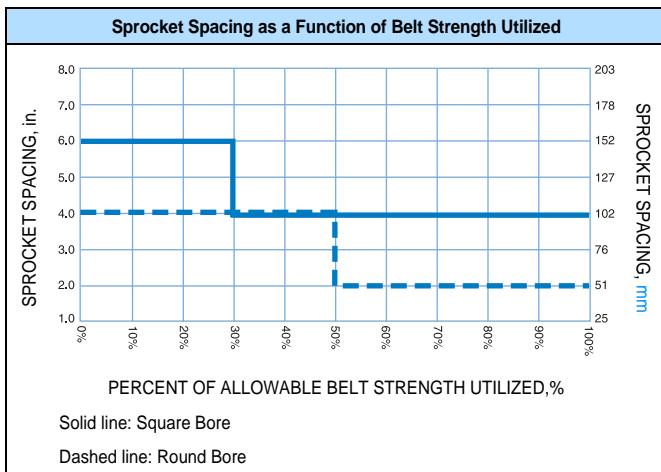

Acetal Sprocket ^a											
No. of Teeth (Chordal Action)	Nom. Pitch Dia. in	Nom. Pitch Dia. mm	Nom. Outer Dia. in	Nom. Outer Dia. mm	Nom. Hub Width in	Nom. Hub Width mm	Available Bore Sizes				
							U.S. Sizes		Metric Sizes		
							Round in	Square in	Round mm	Square mm	
13 (1.92%)	6.2	157.5	6.4	162.6	1.2	30.5	2	1.5		40	
							1-7/16	2.5		60	

a. Contact Customer Service for lead times.

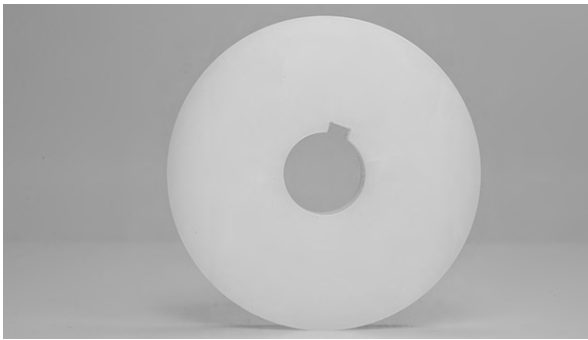
Support Wheel						
Available Pitch Diameter		Available Bore Sizes				
in	mm	U.S. Sizes		Metric Sizes		
		Round in	Square in	Round mm	Square mm	
6.3	160	1-7/16	1.5		40	
		2	2.5		60	

Conveyor Frame Dimensions

Regardless of type or configuration, all conveyors using Intralox belts have some basic dimensional requirements. Specifically, implement dimensions “A”, “B”, “C” and “E” listed in the following table in any design.

For general applications and applications where end transfer of tip-sensitive product is not critical, use the “A” dimension at the bottom of the range.

Conveyor frame dimensions are established using the top of the roller as the top of the belt and the bottom of the module as the bottom of the belt. “B” dimension is based on a 0.5 in (12.7 mm) thick carryway.

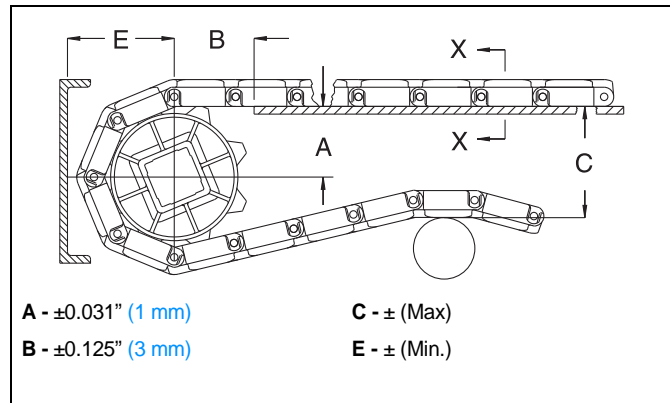

Sprocket Description		A		B		C		E		
Pitch Diameter		Range (Bottom to Top)		in	mm	in	mm	in	mm	
in	mm	No. Teeth	in							mm
DIRECTDRIVE™ STACKER										
6.3	160	13	2.75-2.84	70-72	2.51	64	6.27	159	3.49	89

Dead Plate Gap

Where there is a transfer point from a belt without finger transfer plates to a dead plate, there should be a gap between the surfaces to allow for the chordal action of the belt. As the belt engages its sprockets, chordal action causes the modules to move past a *fixed* point (the tip of the dead plate) with *varying* clearances. The following table shows the minimum amount of gap which occurs at the “low point” of the modules if the tip of the dead plate just comes in contact with the “high point” as the modules pass.

In some installations, it may be desirable to keep the tip of the dead plate in contact with the belt, rather than allow a gap to occur. This can be done by hinging the mounting bracket for the dead plate. This allows the dead plate to move as the modules pass, but results in a small oscillating motion which may present tippage problems for sensitive containers or products.

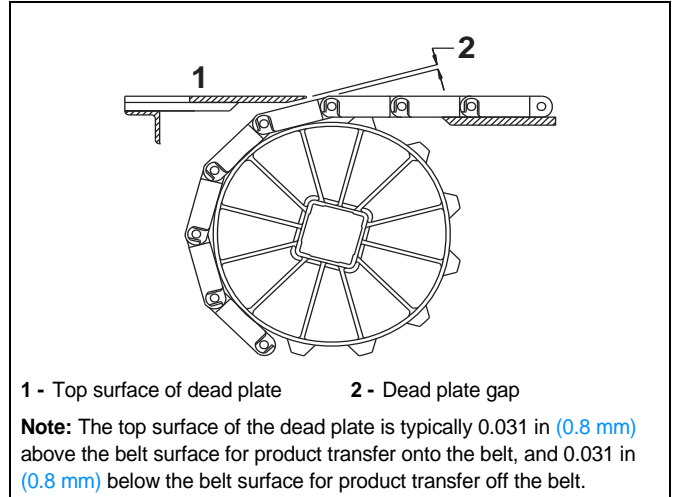

Sprocket Description		Gap		
Pitch Diameter		No. Teeth	in	mm
in	mm			
6.3	160	13	0.091	2.3

Spiralox® DirectDrive™		
	in	mm
Pitch	1.5	38.1
Minimum Width ^a	13.5	343
Maximum Width ^a	61.7	1567
Width Increments	1.0	25.4
Opening Sizes (approx.)	0.52 x 0.39	13 x 10
Open Area (Fully Extended)	44%	
Minimum Open Area (Collapsed)	26%	
Hinge Style	Open	
Drive Method	Hinge-Driven	
Product Notes		
<ul style="list-style-type: none"> • Contact Intralox for precise belt measurements and stock status before designing equipment or ordering a belt. • The Intralox Spiral Program will help predict the strength requirements of most spiral applications, ensuring that the belt is strong enough for the application. • Minimum sprocket indent from the inside belt edge and from the outside belt edge may vary. Contact Customer Service to determine exact placement. • Relatively uniform open area across the width of the belt to aid in freezing and cooling product. • Belt openings pass straight through the belt, making the belt easy to clean. • Robust edge feature adds strength to the outside edge of the belt. • Uses headless rods. <p>WARNING: Do not place fingers in or on this belt. Fingers can get trapped in belt openings, resulting in personal injury. This belt has pinch points due to the belt spreading and collapsing as it flexes to follow the conveyor path. Pinch points can trap fingers, hair, or clothing, causing personal injury. Do not wear loose clothing, loose gloves, or hand/finger jewelry when working near this belt. Call Customer Service for tags, flyers, and stickers containing this warning.</p>		
Additional Information		
<ul style="list-style-type: none"> • See “Belt Selection Process” (page 5) • See “Standard Belt Materials” (page 9) • See “Special Application Belt Materials” (page 9) • See “Friction Factors” (page 13) 		

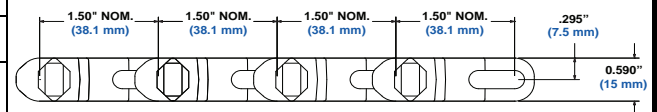
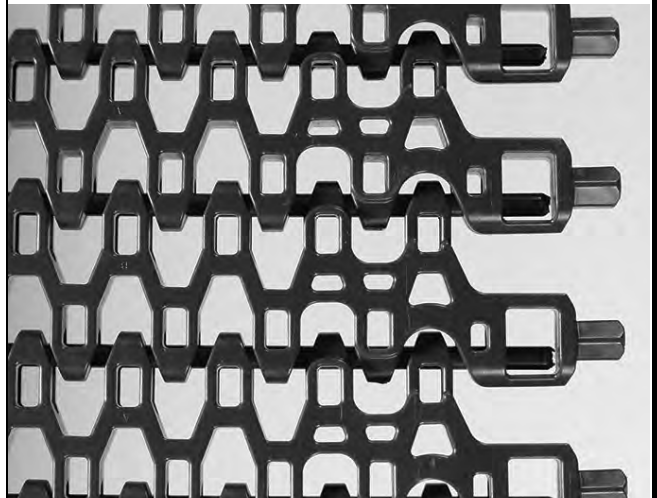
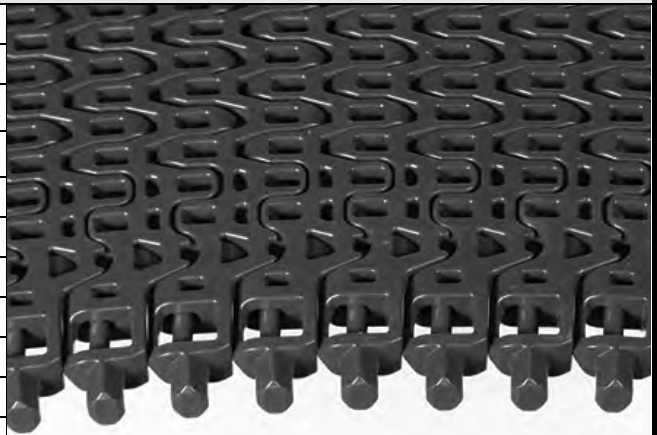

a. Width dimension includes tooth protrusion.

Belt Data									
Belt Material	Standard Rod Material Ø 0.240 in (6.1 mm)	BS Straight Belt Strength	Spiral Belt Strength ^a		Temperature Range (continuous)		W Belt Weight		
			lb/ft	kg/m	lbs.	kg	°F	°C	lb./ft. ²
Acetal	Acetal	1600	2381	475	215	-50 to 200	-46 to 93	1.78	8.69
SELM	Acetal	500	744	375	170	-50 to 200	-46 to 93	1.46	7.13

a. Published spiral belt strengths and their method of calculation vary among spiral manufacturers. Please consult an Intralox Spiral Engineer for accurate comparison of spiral belt strengths.

Spiralox® 1.6		
	in	mm
Pitch	1.5	38.1
Minimum Width ^a	13.5	343
Maximum Width ^a	61.7	1567
Width Increments	0.5	12.7
Opening Sizes (approx.)	0.52 x 0.39	13 x 10
Open Area (Fully Extended)	44%	
Minimum Open Area	26%	
Hinge Style	Open	
Drive Method	Center/Hinge-Driven	
Product Notes		
<ul style="list-style-type: none"> • Contact Intralox for precise belt measurements and stock status before designing equipment or ordering a belt. • Designed for friction drive, capstan spiral applications with a minimum turn radius of 1.6 times the belt width (measured from the inside edge). • The Intralox Spiral Program will help predict the strength requirements of most spiral applications, ensuring that the belt is strong enough for the application. • Minimum sprocket indent from the inside and outside edges of the belt may vary. Discuss exact placement with Intralox Technical Support Group. • Relatively uniform open area across the width of the belt to aid in freezing and cooling product. • Belt openings pass straight through the belt, making the belt easy to clean. • Enhanced beam stiffness • Eliminates product contamination from metal wear debris • Simple, quick repairs and changeovers • Cage-friendly inside edge and frame-friendly outside edge • Robust edge feature adds strength to the outside edge of the belt. • Uses headless rods. <p>WARNING: Do not place fingers in or on this belt. Fingers can get trapped in belt openings, resulting in personal injury. This belt has pinch points due to the belt spreading and collapsing as it flexes to follow the conveyor path. Pinch points can trap fingers, hair, or clothing, causing personal injury. Personnel should not wear loose clothing, loose gloves, or hand/finger jewelry when working near this belt. Call Customer Service for tags, flyers, and stickers containing this warning.</p>		
Additional Information		
<ul style="list-style-type: none"> • See “Belt Selection Process” (page 5) • See “Standard Belt Materials” (page 9) • See “Special Application Belt Materials” (page 9) • See “Friction Factors” (page 13) 		

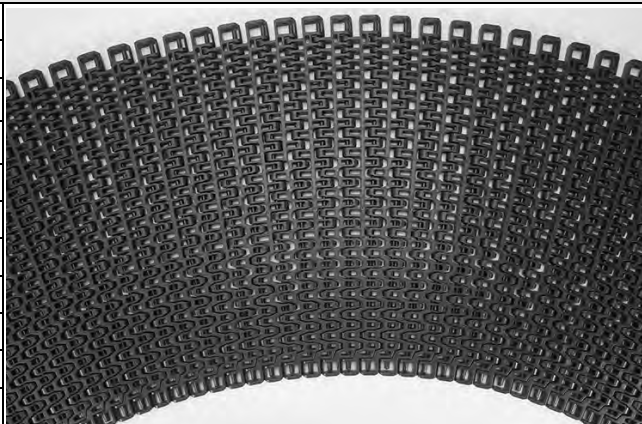
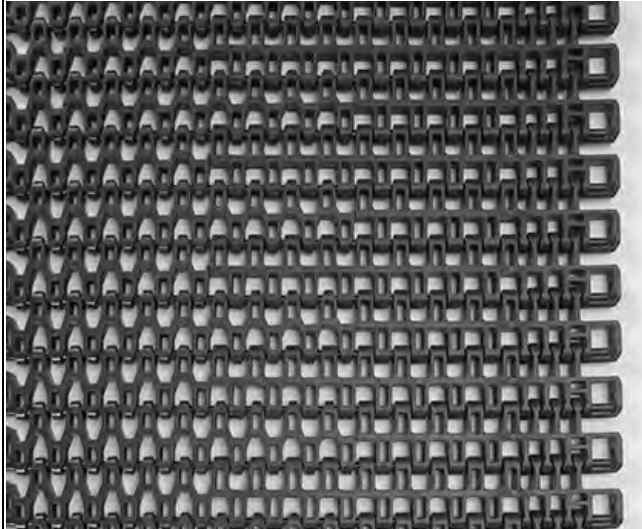
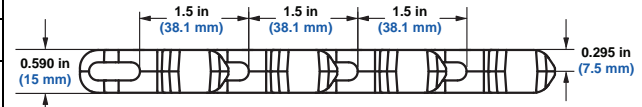



a. Width dimension includes tooth protrusion.

Belt Data										
Belt Material	Standard Rod Material Ø 0.240 in (6.1 mm)	BS	Straight Belt Strength	Spiral Belt Strength ^a		Temperature Range (continuous)		W	Belt Weight	
				lb./ft.	kg/m	lbs.	kg			°F
Acetal	Acetal		1600	2381	475	215	-50 to 200	-46 to 93	1.78	8.69
SELM	Acetal		500	744	375	170	-50 to 200	-46 to 93	1.46	7.13

a. Published curved belt strengths and their method of calculation vary among spiral belt manufacturers. Please consult an Intralox Spiral Engineer for accurate comparison of curve belt strengths.

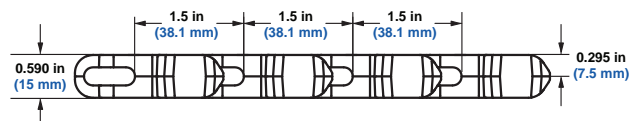
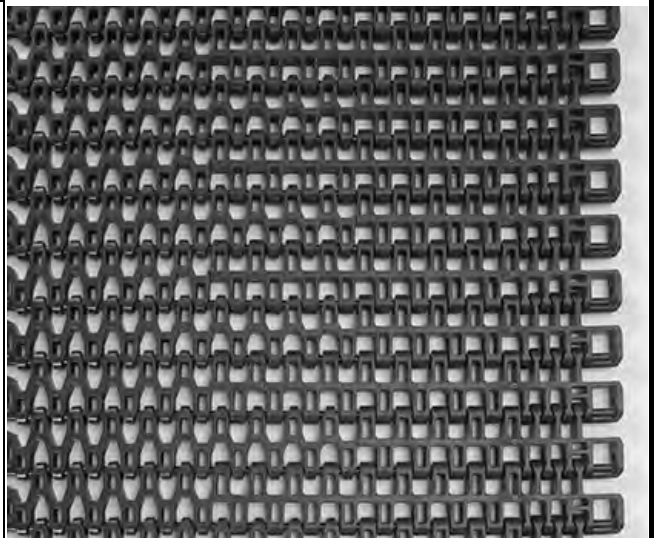
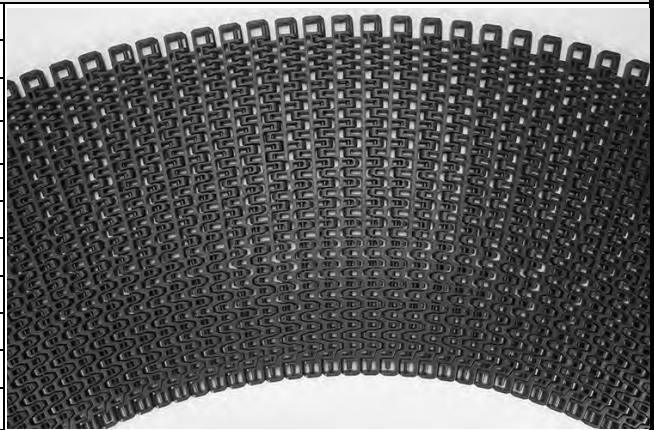
Spiralox® 2.2		
	in	mm
Pitch	1.5	38.1
Minimum Width ^a	13.5	343
Maximum Width ^a	61.7	1567
Width Increments	0.5	12.7
Opening Sizes (approx.)	0.52 x 0.39	13 x 10
Open Area (Fully Extended)	44%	
Minimum Open Area	26%	
Hinge Style	Open	
Drive Method	Center/Hinge-Driven	
Product Notes		
<ul style="list-style-type: none"> • Contact Intralox for precise belt measurements and stock status before designing equipment or ordering a belt. • Designed for friction drive, capstan spiral applications with a minimum turn radius of 2.2 times the belt width (measured from the inside edge). • The Intralox Spiral Program will help predict the strength requirements of most spiral applications, ensuring that the belt is strong enough for the application. • Minimum sprocket indent from the inside and outside edges of the belt may vary. Discuss exact placement with Intralox Technical Support Group. • Relatively uniform open area across the width of the belt to aid in freezing and cooling product. • Belt openings pass straight through the belt, making the belt easy to clean. • Enhanced beam stiffness • Eliminates product contamination from metal wear debris • Simple, quick repairs and changeovers • Cage-friendly inside edge and frame-friendly outside edge • Robust edge feature adds strength to the outside edge of the belt. • Uses headless rods. <p>WARNING: Do not place fingers in or on this belt. Fingers can get trapped in belt openings, resulting in personal injury. This belt has pinch points due to the belt spreading and collapsing as it flexes to follow the conveyor path. Pinch points can trap fingers, hair, or clothing, causing personal injury. Personnel should not wear loose clothing, loose gloves, or hand/finger jewelry when working near this belt. Call Customer Service for tags, flyers, and stickers containing this warning.</p>		
Additional Information		
<ul style="list-style-type: none"> • See “Belt Selection Process” (page 5) • See “Standard Belt Materials” (page 9) • See “Special Application Belt Materials” (page 9) • See “Friction Factors” (page 13) 		



a. Width dimension includes tooth protrusion.

Belt Data										
Belt Material	Standard Rod Material Ø 0.240 in (6.1 mm)	BS	Straight Belt Strength	Spiral Belt Strength ^a		Temperature Range (continuous)		W Belt Weight		
				lb./ft.	kg/m	lbs.	kg	°F	°C	lb./ft. ²
Acetal	Acetal		1600	2381	475	215	-50 to 200	-46 to 93	1.78	8.69
SELM	Acetal		500	744	375	170	-50 to 200	-46 to 93	1.46	7.13

a. Published curved belt strengths and their method of calculation vary among spiral belt manufacturers. Please consult an Intralox Spiral Engineer for accurate comparison of curve belt strengths.

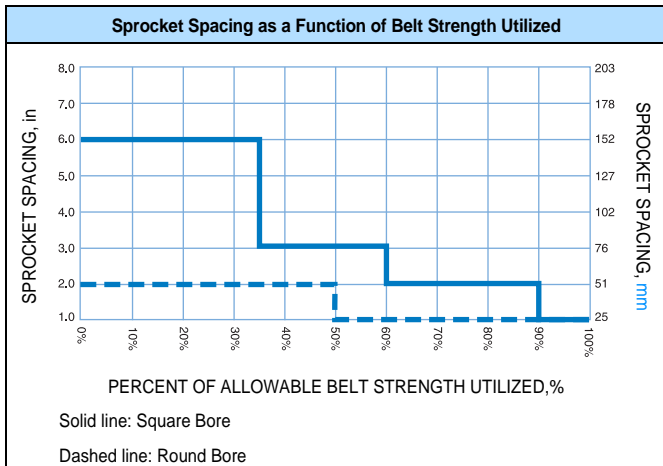

Acetal Sprocket ^a										
No. of Teeth (Chordal Action)	Nom. Pitch Dia. in	Nom. Pitch Dia. mm	Nom. Outer Dia. in	Nom. Outer Dia. mm	Nom. Hub Width in	Nom. Hub Width mm	Available Bore Sizes			
							U.S. Sizes		Metric Sizes	
							Round in	Square in	Round mm	Square mm
13 (2.97%)	6.2	157	6.4	163	1.2	30.5	1-7/16 2	1.5 2.5		40 60



a. Contact Customer Service for lead times.

Support Wheel					
Available Pitch Diameter		Available Bore Sizes			
in	mm	U.S. Sizes		Metric Sizes	
		Round in	Square in	Round mm	Square mm
6.3	160	1-7/16 2	1.5 2.5		40 60

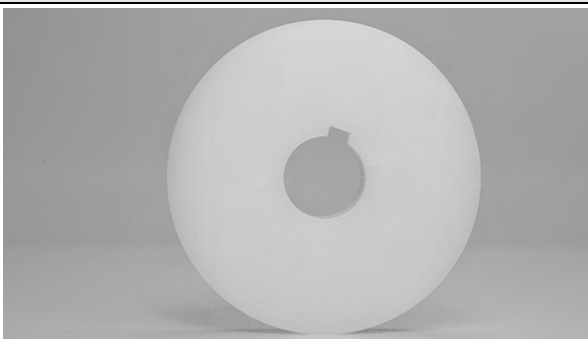

Overlapping Sideguards		
Available Height		Available Materials
in	mm	
0.50	12.7	Acetal
1.0	25.4	Acetal



Note: Maximizes product carrying capacity: they fit into the very edge of the belt, with no indent.

Note: Assembly does not require “finger cuts” on the modules, so the belt’s beam strength is uncompromised.

Note: Turn ratio for 0.50 in (12.7 mm) Overlapping Sideguards is 1.6.

Note: Makes the belt’s outer edge more snag-resistant.

Note: Keeps small products from falling through belt gaps.

Lane Dividers				
Available Height		Available Materials		
in	mm			
0.75	19	Acetal, SELM		

Conveyor Frame Dimensions

Regardless of type or configuration, all conveyors using Intralox belts have some basic dimensional requirements. Specifically, dimensions “A”, “B”, “C” and “E” listed below should be implemented in any design.

For general applications and applications where end transfer of tip-sensitive product is not critical, use the “A” dimension at the bottom of the range.

Conveyor frame dimensions are established using the top of the roller as the top of the belt and the bottom of the module as the bottom of the belt. “B” dimension is based on a 0.5 in (12.7 mm) thick carryway.

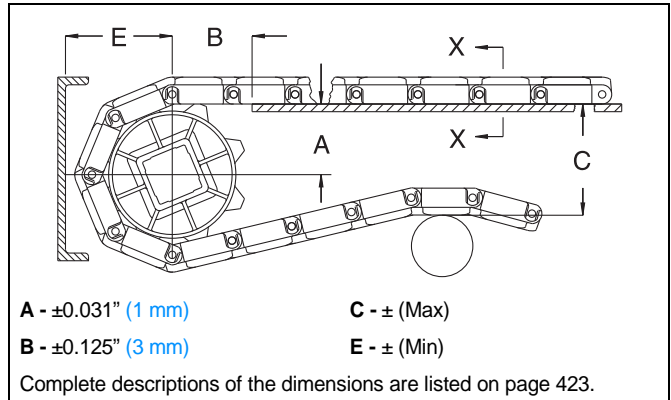

Sprocket Description		A		B		C		E	
Pitch Diameter		Range (Bottom to Top)		in.	mm	in.	mm	in.	mm
in.	mm	No. Teeth	in.						
SPIRALOX® DirectDrive									
6.3	160	13	2.75-2.84	70-72	2.51	64	6.27	159	3.49 89

Dead Plate Gap

Where there is a transfer point from a belt without finger transfer plates to a dead plate, there should be a gap between the surfaces to allow for the chordal action of the belt. As the belt engages its sprockets, chordal action causes the modules to move past a *fixed* point (the tip of the dead plate) with *varying* clearances. The table below shows the minimum amount of gap which occurs at the “low point” of the modules if the tip of the dead plate just comes in contact with the “high point” as the modules pass.

In some installations it may be desirable to keep the tip of the dead plate in contact with the belt, rather than allow a gap to occur. This can be done by hinging the mounting bracket for the dead plate. This allows the dead plate to move as the modules pass, but results in a small oscillating motion which may present tippage problems for sensitive containers or products.

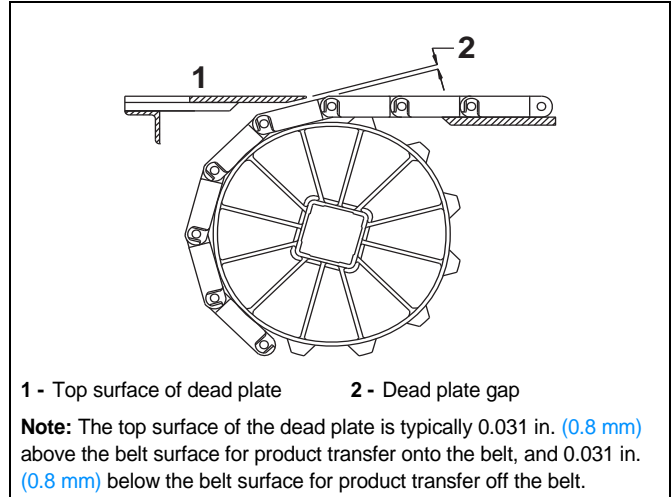

Sprocket Description		Gap		
Pitch Diameter		No. Teeth	in.	mm
in.	mm			
6.3	160	13	0.091	2.3

HOLD DOWN RAILS AND WEARSTRIPS

Intralox recommends using continuous hold down rails through an entire turn, starting at a distance of 1X the belt width before the turn and ending 1X the belt width after the

turn. This applies to both carryway and returnway. The use of hold down rails along both side of the belt over the full carryway is recommended but not mandatory. See “*Custom wearstrips*” (page 416).

FLUSH EDGE WITH WEARSTRIP

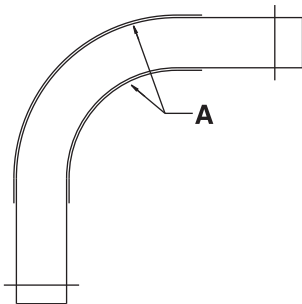

A - HOLD DOWN RAIL PLACEMENT

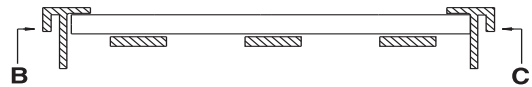

B - OUTSIDE HOLD DOWN RAIL

C - INSIDE HOLD DOWN RAIL

Fig. 2-14 HOLD DOWN RAILS AND WEARSTRIPS FOR SERIES 2900 FLAT-TURNS

BELT SELECTION INSTRUCTIONS

ENGINEERING PROGRAM ANALYSIS FOR SERIES 2900

Intralox Customer Service Technical Support Group can calculate the estimated belt pull for radius applications using **Series 2900**. The following information is required (refer to "Radius belt data sheet" (page 469)):

- Any environmental conditions which may affect the friction coefficient (for dirty or abrasive conditions, use higher friction coefficients than normal)
- Belt width
- Length of each straight run
- Turning angle of each turn

- Turn direction of each turn
- Inside turning radius of each turn
- Carryway/hold down rail material
- Product loading lb/ft² (kg/m²)
- Product back-up conditions
- Belt speed
- Elevation changes on each section
- Operating temperatures.

For assistance with radius belt and low-tension capstan drive spiral selections, contact Intralox Customer Service Technical Support Group. The Engineering Program should be run to ensure that the belt is strong enough for the radius application in question.

SERIES 2900 DESIGN GUIDE SUMMARY

For more information, see the **Installation, Maintenance and Troubleshooting manual** available from Intralox.

- A** - The minimum turning radius for **Series 2900** is 1.6 times the belt width, measured from the inside edge for the standard edge.
- B** - The minimum straight run required between turns of opposing direction is 1.6 times the belt width. Shorter straight sections will lead to high wear on the edge guide rail and high pull stresses in the belt.
- C** - There is no minimum straight run required between turns that are in the same direction.
- D** - The minimum final straight run (leading to the drive shaft) should be a minimum of 5 ft. (1.5 m). If 5 ft. (1.5 m) is not feasible, a shorter distance (down to 1.5 times belt width) would require a weighted take up in order to avoid sprocket wear and tracking problems. See "Special Take-Up Arrangements" (page 431).

- E** - The minimum length of the first straight run (immediately after the idle shaft) is 1.5 times the belt width. When shorter lengths are required (down to 1.0 times the width), an idle roller may be used in place of sprockets.
- F** - IDLE SHAFT
- G** - 1ST TURN
- H** - BELT WIDTH
- I** - BELT TRAVEL
- J** - 2ND TURN
- K** - DRIVE MOTOR
- L** - DRIVE SHAFT

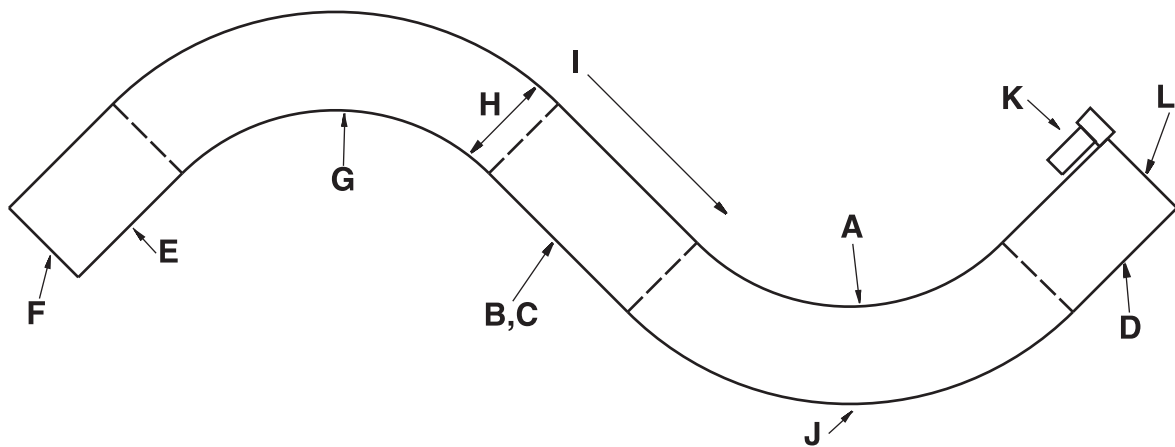
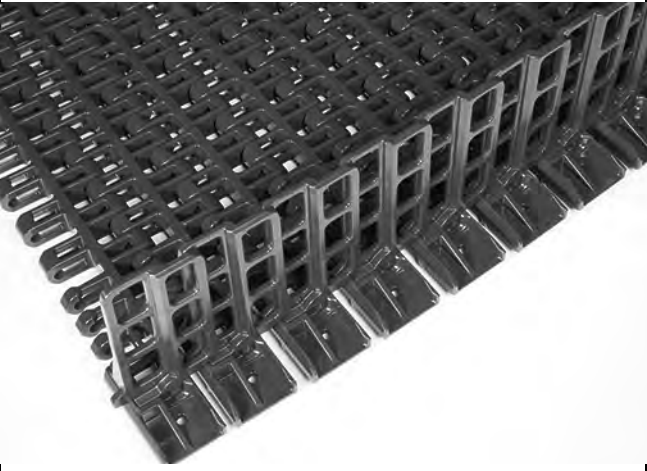

Fig. 2-15 TYPICAL 2-TURN RADIUS LAYOUT

DirectDrive™ Stacker		
	in	mm
Pitch	1.5	38.1
Minimum Width	12	304.8
Width Increments	1.00	25.4
Opening Sizes (approx.)	0.52 x 0.39	13.0 x 10.0
Open Area (Fully Extended)	44%	
Minimum Open Area	26%	
Hinge Style	Open	
Drive Method	Hinge-Driven	



Product Notes

- Contact Intralox for precise belt measurements and stock status before designing equipment or ordering a belt.
- Designed for stacker applications using the patented DirectDrive technology.
- The Intralox Spiral Program can help predict the strength requirements of most spiral applications, ensuring the belt is strong enough for the application. Contact our Technical Service Group for more information.
- Lightweight, strong belt with smooth surface grid for good product release.
- Relatively uniform open area across the width of the belt to aid in freezing and cooling of product.
- Belt openings pass straight through the belt, making the belt easy to clean.
- 60 mm, 80 mm, & 100 mm tier spacing available.
- Sideplates are permanently installed and cannot be replaced.
- Uses headless rods.

WARNING: Do not place fingers in or on this belt. Fingers can get trapped in belt openings, resulting in personal injury. This belt has pinch points due to the belt spreading and collapsing as it flexes to follow the conveyor path. Pinch points can trap fingers, hair, or clothing, causing personal injury. Do not wear loose clothing, loose gloves, or hand/finger jewelry when working near this belt. Call Customer Service for tags, flyers, and stickers containing this warning.



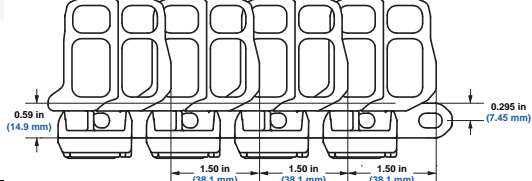

Additional Information									
<ul style="list-style-type: none"> See "Belt Selection Process" (page 5) See "Standard Belt Materials" (page 9) See "Special Application Belt Materials" (page 9) See "Friction Factors" (page 13) 									

SECTION 2

2950

Belt Data									
Belt Material	Standard Rod Material Ø 0.240 in (6.1 mm)	BS Straight Belt Strength		Spiral Belt Strength ^a		Temperature Range (continuous) ^b		W Belt Weight	
		lb./ft	kg/m	lbs.	kg	°F	°C	lb./ft. ²	kg/m ²
Acetal	Acetal	1600	2381	475	215	-50 to 200	-46 to 93	2.18	10.64

a. Published spiral belt strengths and their method of calculation vary among spiral manufacturers. Please consult an Intralox Spiral Engineer for accurate comparison of spiral belt strengths.

b. Sideflexing applications should not exceed 180 °F (82 °C).

Sprocket and Support Quantity Reference				
Belt Width Range ^a		Minimum Number of Sprockets Per Shaft ^b	Wearstrips	
in	mm		Carryway	Returnway
24	610	4	2	2
26	660	4	2	2
28	711	5	2	2
30	762	5	2	2
32	813	5	2	2
34	864	6	2	2
36	914	6	2	2
38	965	6	3	3
40	1016	7	3	3
42	1067	7	3	3
44	1118	7	3	3
46	1168	8	3	3
48	1219	8	3	3
50	1270	8	3	3
52	1321	9	3	3
54	1372	9	3	3
56	1422	9	3	3
58	1473	10	3	3
60	1524	10	3	3

- a. If your belt width exceeds a number listed in the table, please refer to the sprocket and support material minimums for the next larger width range listed. Belts are available in 1.00 in. (25.4 mm) increments beginning with minimum width of 24 in. (609.6 mm). **If the actual width is critical, consult Customer Service.**
- b. These are the minimum number of sprockets. Additional sprockets may be required for heavily loaded applications. The center sprocket should be locked down. See Center Sprocket Offset chart for lock down location

Center Sprocket Offset		
Number of Links	Offset	
	in	mm
even	0.0	0.0
odd	0.5	12.7

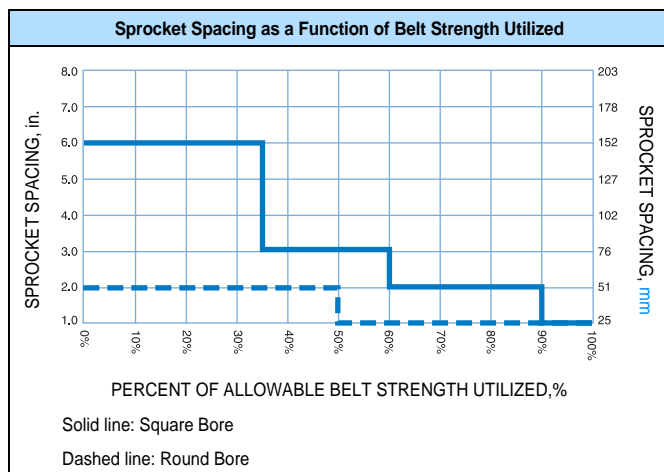

Acetal Sprocket^a											
No. of Teeth (Chordal Action)	Nom. Pitch Dia. in	Nom. Pitch Dia. mm	Nom. Outer Dia. in	Nom. Outer Dia. mm	Nom. Hub Width in	Nom. Hub Width mm	Available Bore Sizes				
							U.S. Sizes		Metric Sizes		
							Round in	Square in	Round mm	Square mm	
13 (2.97%)	6.2	157	6.4	163	1.2	30.5	1-7/16 2	1.5 2.5		40 60	

a. Contact Customer Service for lead times.

Support Wheel						
Available Pitch Diameter		Available Bore Sizes				
in	mm	U.S. Sizes		Metric Sizes		
		Round in	Square in	Round mm	Square mm	
6.3	160	1-7/16 2	1.5 2.5		40 60	

Conveyor Frame Dimensions

Regardless of type or configuration, all conveyors using Intralox belts have some basic dimensional requirements. Specifically, implement dimensions “A”, “B”, “C” and “E” listed in the following table in any design.

For general applications and applications where end transfer of tip-sensitive product is not critical, use the “A” dimension at the bottom of the range.

Conveyor frame dimensions are established using the top of the roller as the top of the belt and the bottom of the module as the bottom of the belt. “B” dimension is based on a 0.5 in. (12.7 mm) thick carryway.

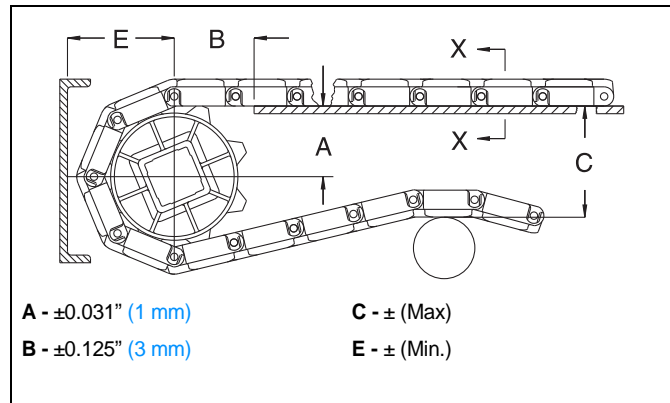

Sprocket Description		A		B		C		E		
Pitch Diameter		Range (Bottom to Top)		in	mm	in	mm	in	mm	
in	mm	No. Teeth	in							mm
DIRECTDRIVE™ STACKER										
6.2	157	13	2.71-2.81	69-71	2.47	63	6.20	157	3.46	88

Dead Plate Gap

Where there is a transfer point from a belt without finger transfer plates to a dead plate, there should be a gap between the surfaces to allow for the chordal action of the belt. As the belt engages its sprockets, chordal action causes the modules to move past a *fixed* point (the tip of the dead plate) with *varying* clearances. The following table shows the minimum amount of gap which occurs at the “low point” of the modules if the tip of the dead plate just comes in contact with the “high point” as the modules pass.

In some installations it may be desirable to keep the tip of the dead plate in contact with the belt, rather than allow a gap to occur. This can be done by hinging the mounting bracket for the dead plate. This allows the dead plate to move as the modules pass, but results in a small oscillating motion which may present tippage problems for sensitive containers or products.

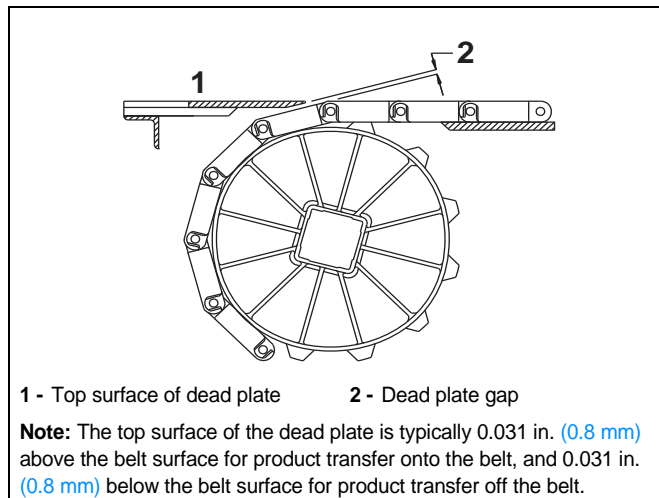

Sprocket Description		Gap		
Pitch Diameter		No. Teeth	in	mm
in	mm			
6.2	157	13	0.092	2.3

SQUARE SHAFTS

MACHINED TO CUSTOMER SPECIFICATIONS

After the stock is cut to length, the raw shaft is precision straightened. The bearing journals are turned, followed by the cutting of retainer ring grooves, keyways and chamfers*. The final step is a thorough, quality control inspection before shipping. Contact Customer service for a form to fill in specifying shaft dimensions.

*If the shaft is to operate under high belt loads, retainer ring grooves are not recommended. Self-set or split heavy-duty retainer type rings are recommended in these cases. Contact the Technical Support Group for retainer ring recommendations.

Note: Inform Customer Service if shaft will be used in a Hollow Gear Box.

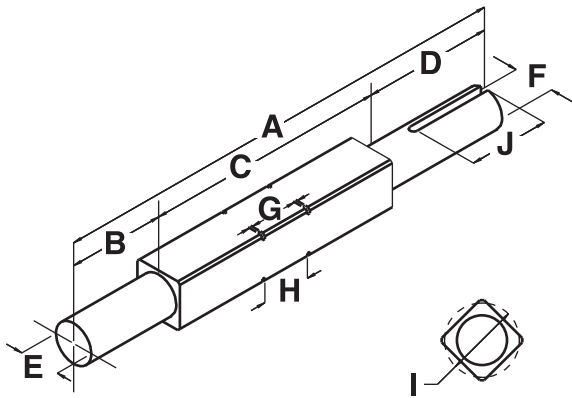

Fig. 2-16 Shaft dimensions

- DIMENSIONS REQUIRED:**
- A** - LENGTH, overall
 - B** - LENGTH, bearing-end journal
 - C** - LENGTH, square section
 - D** - LENGTH, drive-end journal and keyway dimensions
 - E** - DIAMETER, bearing journal
 - F** - DIAMETER, drive-end journal
 - G** - WIDTH, retainer ring groove
 - H** - WIDTH, sprocket hub
 - I** - DIAMETER, ring groove
 - J** - LENGTH of keyway

SHAFTS AVAILABLE FROM INTRALOX USA ^a				
SHAFT TOLERANCES IN INCHES				
Square Size	Aluminum (6061-T6)	Carbon Steel (C-1018)	Stainless Steel (303/304)	Stainless Steel (316)
5/8 in	±0.003	+0.000 -0.003	+0.000 -0.004	+0.000 -0.004
1 in	+0.003 -0.003	+0.000 -0.003	+0.000 -0.004	+0.000 -0.004
1.5 in	+0.003 -0.003	+0.000 -0.003	+0.000 -0.006	+0.000 -0.006
2.5 in	N/A	+0.000 -0.004	+0.000 -0.008	+0.000 -0.008
3.5 in ^b	N/A	+0.000 -0.005	+0.000 -0.012 (304 CR)	N/A

a. Consult Intralox for shafts longer than 12 ft.

b. 3.5 in carbon steel shafts can be nickel plated for corrosion resistance.

SHAFTS AVAILABLE FROM INTRALOX EUROPE ^a		
SHAFT TOLERANCES IN MM		
Square Size	Carbon Steel (KG-37)	Stainless Steel (303/304)
25 mm	+0.000 -0.130	+0.000 -0.130
40 mm	+0.000 -0.160	+0.000 -0.160
60 mm	+0.000 -0.180	+0.000 -0.180
65 mm	+0.000 -0.180	+0.000 -0.180
90 mm	+0.000 -0.220	+0.000 -0.220

a. Consult Intralox for shafts longer than 2 m.

SHAFT DIMENSIONS AND TOLERANCES			
Shaft Size	Retainer Ring Groove and Chamfer Dimensions		
	Groove Diam.	Width	Chamfer ^a
5/8 in	0.762 ± 0.003 in	0.046 + 0.003/- 0.000 in	0.822 ± 0.010 in
1 in	1.219 ± 0.005 in	0.056 + 0.004/- 0.000 in	1.314 ± 0.010 in
1.5 in	1.913 ± 0.005 in	0.086 + 0.004/- 0.000 in	2.022 ± 0.010 in
2.5 in	3.287 ± 0.005 in	0.120 + 0.004/- 0.000 in	3.436 ± 0.010 in
3.5 in	4.702 ± 0.005 in	0.120 + 0.004/- 0.000 in	4.850 ± 0.010 in
25.4 mm	30 ± 0.1 mm	2.0 + 0.15/- 0.00 mm	33 ± 0.25 mm
40 mm	51 ± 0.1 mm	2.5 + 0.15/- 0.00 mm	54 ± 0.25 mm
60 mm	80 ± 0.1 mm	3.5 + 0.15/- 0.00 mm	82 ± 0.25 mm
65 mm	85 ± 0.1 mm	3.5 + 0.15/- 0.00 mm	89 ± 0.25 mm
90 mm	120 ± 0.1 mm	4.5 + 0.15/- 0.00 mm	124 ± 0.25 mm

Note: some instances, the retainer ring grooves will be offset from the shaft center. See "Retaining sprockets" (page 426)

a. Shaft must be chamfered for Series 200, 400 and 800 molded sprockets to fit.

TOLERANCES (Unless otherwise specified)

OVERALL LENGTH < 48 in ± 0.061 in (< 1200 ± 0.8 mm)
> 48 in ± 0.125 in (> 1200 ± 1.2 mm)

JOURNAL DIAM. - 0.0005 in/- 0.003 in (Øh7 vlg. NEN-ISO 286-2)

KEYWAY WIDTHS + 0.003 in/- 0.000 in (+ 0.05/- 0.00 mm)

SURFACE FINISHES

JOURNAL 63 microinches (1.6 micrometers)

OTHER MACHINED SURFACES 125 microinches (3.25 micrometers)

Unless otherwise specified — USA keyways are for parallel square keys (ANSI B17.1 - 1967, R1973).

Metric keyways are for flat, inlaid keys with round ends (DIN 6885-A).

RETAINER RINGS/CENTER SPROCKET OFFSET

STANDARD RETAINER RINGS

- **PLASTIC RETAINER RINGS** are available in sizes to fit 1.5 in. and 2.5 in. square shafts.
- Standard Retainer Rings are made from Polysulfone.
- The temperature range of Polysulfone is -125 °F to 300 °F (-98 °C to 149 °C).
- Standard Retainer Rings require grooves identical to those used for Stainless Steel Retainer Rings on 1.5 in. and 2.5 in. shafts (see groove chart in Stainless Steel Retainer Ring section for information).
- Standard Retainer Rings have the following restrictions:

Standard Retainer Ring Restrictions					
Retainer Ring Size	Standard Retainer Rings will NOT work with the following sprockets				
	Series	Pitch Diameter		Bore Size	
		in.	mm	in.	mm
1.5 in.	400	4.0	102	1.5	40
	1600	3.2	81	1.5	40
2.5 in.	400	5.2	132	2.5	40
	1100	3.1	79	2.5	40

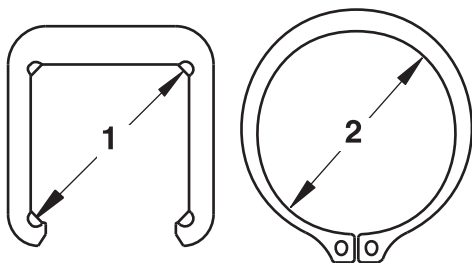

Fig. 2-17 Retainer rings

1. Ring Groove Diameter for Polysulfone Retainer Rings
2. Ring Groove Diameter for Steel Retainer Rings

- **STAINLESS STEEL RETAINER RINGS** are available to fit 5/8 in., 1.0 in., 1.5 in., 2.5 in., 3.5 in., 25.4 mm, 40 mm, 60 mm, 65 mm, and 90 mm square shafts.
- The following ANSI Type 3AMI rings, conforming to MIL SPEC R-2124B are available

RETAINER RING GROOVE AND CHAMFER DIMENSIONS			
Shaft Size	Retainer Ring Groove and Chamfer Dimensions		
	Groove Diam.	Width	Chamfer ^a
5/8 in	0.762 ± 0.003 in	0.046 + 0.003/- 0.000 in	0.822 ± 0.010 in
1 in	1.219 ± 0.005 in	0.056 + 0.004/- 0.000 in	1.314 ± 0.010 in
1.5 in	1.913 ± 0.005 in	0.086 + 0.004/- 0.000 in	2.022 ± 0.010 in
2.5 in	3.287 ± 0.005 in	0.120 + 0.004/- 0.000 in	3.436 ± 0.010 in
3.5 in	4.702 ± 0.005 in	0.120 + 0.004/- 0.000 in	4.850 ± 0.010 in
25.4 mm	30 ± 0.1 mm	2.0 + 0.15/- 0.00 mm	33 ± 0.25 mm
40 mm	51 ± 0.1 mm	2.5 + 0.15/- 0.00 mm	54 ± 0.25 mm
60 mm	80 ± 0.1 mm	3.5 + 0.15/- 0.00 mm	82 ± 0.25 mm
65 mm	85 ± 0.1 mm	3.5 + 0.15/- 0.00 mm	89 ± 0.25 mm
90 mm	120 ± 0.1 mm	4.5 + 0.15/- 0.00 mm	124 ± 0.25 mm

Note: some instances, the retainer ring grooves will be offset from the shaft center. See "Retaining sprockets" (page 426)

- Shaft must be chamfered for Series 200, 400 and 800 molded sprockets to fit.

- Standard Retainer Rings have the following restrictions:

Stainless Steel Retainer Ring Restrictions			
Retainer Ring Size	Stainless Steel Retainer Rings will NOT work with the following sprockets		
	Series	Pitch Diameter ^a	
		in.	mm
1.219 in.	900	2.1	53
	1100	2.3	58

- To lock down the **Series 900** 2.1 in. (53 mm) and (58 mm) pitch diameter sprockets, a set screw, placed on each side of the sprocket, is required. Contact Intralox Sales Engineering for more information.

Locked Sprocket position on the shaft

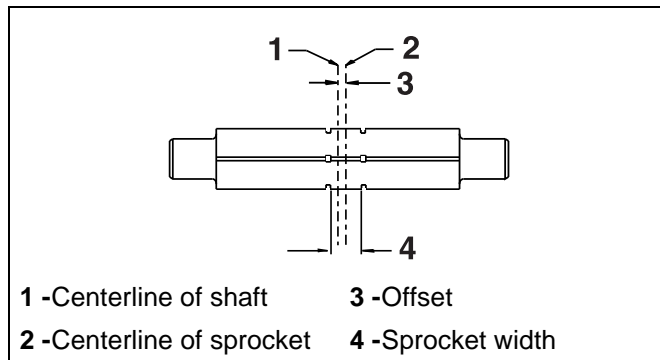

Center Sprocket Offset					
Series	Number of Links	Offset		Max. Sprocket Spacing	
		in	mm	in	mm
100	even	0	0	6	152
	odd	0.12	3	6	152
200	even/odd	0	0	7.5	191
200 RR	even/odd	0.09	2.3	7.5	191
400	even	0	0	6	152
	odd	0.16	4	6	152
400 RT, ARB, TRT	See bottom of chart.				
550	even	0	0	5	127
	odd	0.5	12.7	5	127
800	even/odd	0	0	6	152
800 Angled EZ Clean ^a	even/odd	0.16	4	6	152
800 RR	even	3	76	6	152
	odd	0	0	6	152
850	even/odd	0	0	6	152
888	See Series 888 section in the Installation Instructions or call Customer Service.				
900	even	0	0	4	102
	odd	0.16	4	4	102
900 OFG	See Series 900 section in the Installation Instructions or call Customer Service.				
1000	even	0	0	6	152
	odd	0.25	6.44	6	152
1100 ^b	even (whole)	0	0	4	102
	odd (whole)	0.5	12.7	4	102
	even/odd (0.5 in 12.7 mm increments)	0.25	6.35	4	102
1100 EZ Tracking Sprockets	even (whole)	0.19	4.8	4	102
	odd (whole)	0.31	7.9	4	102
	even/odd (0.5 in 12.7 mm increments)	0.06	1.52	4	102
1200	See Series 1200 section in the Installation Instructions or call Customer Service.				
1400	even	0	0	6	152
	odd	0.5	12.7	6	152

Center Sprocket Offset					
Series	Number of Links	Offset		Max. Sprocket Spacing	
		in	mm	in	mm
1400 FG	See Series 1400 section in the Installation Instructions or call Customer Service.			6	152
1500	See Series 1500 section in the Installation Instructions or call Customer Service.			6	152
1600	even/odd	0	0	4	102
1650 ^c	even/odd	0.25	6.4	4	102
1700	even	0.5	12.7	5	127
	odd	0	0		
1800	even/odd	0	0	6	152
1900	See Series 1900 section in the Installation Instructions or call Customer Service.			3	76
2100	even/odd	1.97	50	3.94	100
2200 ^d	even	0.25 to the left ^e	6.4 to the left ^e	4	102
	odd	0.25 to the right ^f	6.4 to the right ^f	4	102
2300	even	0	0	6	152
	odd	1.5	38	6	152
2400 ^{d g}	even	0.125 to the left ^e	3.2 to the left ^e	6	152
	odd	0.125 to the right ^f	3.2 to the right ^f	6	152
2600	even/odd	0	0	8	203
2700	even/odd	0	0	8	203
2800	even	0	0	6	152
	odd	0.5	12.7		
4400	even/odd	0.5	12.7	9	229
4500	even	0.5	12.7	6	152
	odd	0	0	6	152
4500 Dual Tooth Sprockets	even	0	0	6	152
	odd	0.5	12.7	6	152
9000	even	0.5	12.7	4	102
	odd	0	0	4	102
10000 Hinge Drive (preferred)	even	0.25 to the left ^e	6.3 to the left ^e	5.91	150
	odd	0.25 to the right ^f	6.3 to the right ^f	5.91	150
10000 Center Drive	even	0.25 to the right ^f	6.3 to the right ^f	5.91	150
	odd	0.25 to the left ^e	6.3 to the left ^e	5.91	150
400 RT, ARB, TRT	Number of Rollers per row				
	even	0	0	6	152
odd	1	25.4	6s	152	

- a. 6, 10, and 16 tooth sprockets can be placed on belt centerline
- b. The 8 and 12 tooth steel sprockets can be placed on belt centerline
- c. 20 tooth sprocket has 0 offset
- d. When determining number of links, drop the 0.5 link
- e. To the left of the shaft centerline in direction away from keyed journal
- f. To the right of the shaft centerline in direction toward keyed journal
- g. Assuming belt is running in preferred direction

SELF-SET RETAINER RINGS



- **SELF-SET RETAINER RINGS** are available to fit 1.0 in., 1.5 in., 2.5 in., 3.5 in., **40 mm**, **60 mm**, and **65 mm** shafts.
- Retainer Rings are made from non corrosive 316 stainless steel.
- There is no need for machined grooves on the shaft and the shaft does not need to be

removed to install these retainer rings.

- Self-Set Retainer Rings are USDA-FSIS accepted.
- Self-Set Retainer Rings snap into place on the square shaft and are fixed in position with a unique set screw that cannot fall out of the retainer ring during operation.
- The shaft must have chamfered edges for the retainer ring to work properly.

- Self-Set Retainer Rings are not recommended in applications where high lateral forces are to be expected.
- Self-Set Retainer Rings have the following restrictions:

Self-Set Retainer Ring Restrictions			
Retainer Ring Size	Self-Set Retainer Rings will NOT work with the following sprockets		
	Series	Pitch Diameter	
		in.	mm
1.0 in.	100	2.0	51
	900	2.1	53
	1100	2.3	58
40 mm	900	3.1	79
	1000	3.1	79
	1100	3.1	79
65 mm	1600	3.2	81
	400	5.2	132

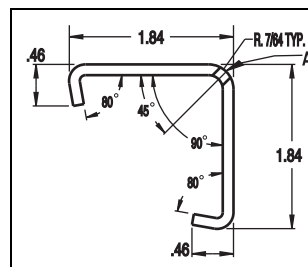

A -Custom set screw, fully inserted, head first, from this side

ROUND SHAFT RETAINER RINGS

- **ROUND SHAFT RETAINER RINGS** are available to fit 0.75 in., 1.0 in., **20 mm**, and **25.4 mm** round shafts.
- These retainer rings are made of stainless steel.
- These retainer rings are for use with the Series 1100 1.6 in. (**41 mm**) and 2.3 in. (**58 mm**) pitch diameter sprockets.



- These retainer rings do not require a groove for placement, they stay in place using friction (It is very important that grooves are not used on round shafting, as this will cause fatigue and shaft failure).

SPLIT COLLAR RETAINER RINGS

Split collar retainer rings are available to fit the following shaft sizes:

Split Collar Retainer Ring/Shaft Sizes	
Square Shaft	Round Shaft
1.5 in	3/4 in
2.5 in	1 in
40 mm	1-3/16 in
60 mm	1-1/4 in
	1-3/8 in
	1-7/16 in
	1-1/2 in
	2 in



- The retainer rings are made from 304 Stainless Steel.
- For use in applications with high lateral loads on the sprockets.
- These retainer rings do not require the shaft to be chamfered and the shaft does not have to be removed, providing ease of installation.

• Split Collar Retainer Rings have the following restrictions:

Split Collar Retainer Ring Restrictions			
Retainer Ring Size	Split Collar Retainer Rings will NOT work with the following sprockets		
	Series	Pitch Diameter	
		in.	mm
1.5 in. and 40 mm	400	4.0	102
	900	3.1	79
	900	3.5	89
	1000	3.1	79
	1100	3.1	79
	1100	3.5	89
2.5 in. and 60 mm	1600	3.2	81
	400	5.2	132
	1100	4.6	117
	1400	4.9	124
	2600	5.2	132
	2700	5.2	132

ROUND BORE ADAPTERS

Sprocket inserts are available to adapt 1.5 in square bore sprockets to use 1 in diameter shafts. They are only recommended for lightly loaded belts or for narrow belt widths, up to 18 in (460 mm).

Adapters are made in glass-filled polypropylene for strength and chemical resistance. However, these adapters are not to be used with split or abrasion resistant sprockets.

Two adapter sizes are available - 2.5 in (64 mm) and 3.5 in (89 mm) long. Set screws are provided to retain the sprockets on the adapters and to lock the center sprocket to the shaft. The 3.5 in (89 mm) adapter has a third tapped hole to accommodate a range of hub widths. Refer to the table at right to determine which adapter to use with a given sprocket hub width.

For certain sprocket hub width/adaptor size combinations, more than one sprocket can be placed on each adapter. See the Round Bore Adapter Selection Table under the sprocket/adaptor column for more information.

The 2.5 in (64 mm) adapter has a torque limit of 875 in-lb (10,000 mm-kg). The 3.5 in (89 mm) adapter is limited to 1200 in-lb (13,800 mm-kg). The operating temperature limits are between 45 °F (7 °C) and 120 °F (50 °C).

Round Bore Adapters are not recommended for use with Split Sprockets or Abrasion Resistant Sprockets.

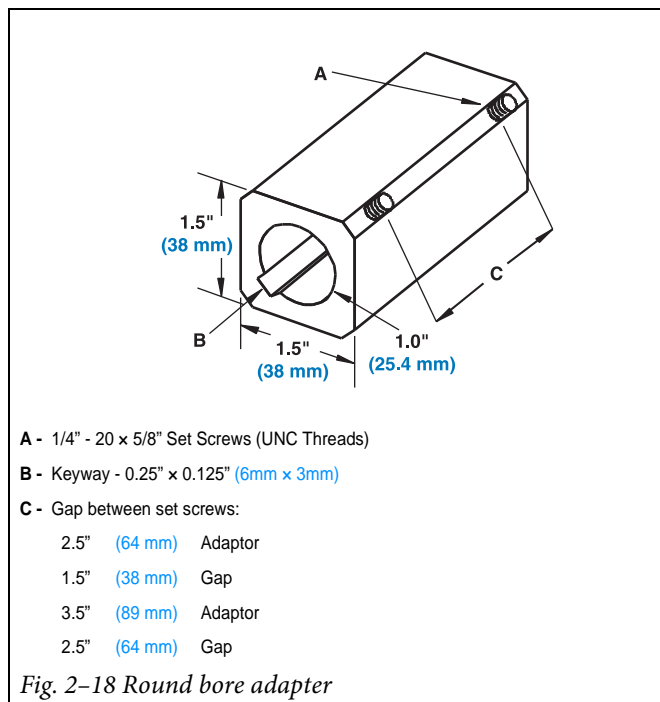
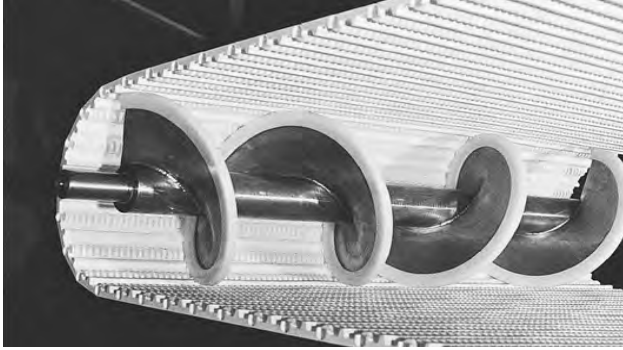

Fig. 2-18 Round bore adapter

Round Bore Adapter Selection Table ^a							
Sprocket Hub Widths	Center Locked Sprocket				Floating Sprockets		
	Adapter Size		Sprockets/Adapter	Adapter Sizes		Sprockets/Adapter	
in	mm	in		mm	in		mm
0.75	19	2.5	64	2	2.5	64	1
1.00	25	2.5	64	1	3.5	89	1
1.25	32	3.5	89	2	3.5	89	1
1.50	38	2.5	64	1	3.5	89	1
2.50	64	3.5	89	1	3.5	89	1

a. Spacers may be needed to lock down center sprockets on adapters.

SCROLL IDLERS



Scrolls from Intralox may be used in applications where the drive end shaft and sprockets must be kept clean. The curved, flighted surfaces of the scroll direct debris away from the belt center, toward the edges, where it can fall harmlessly to the floor or receptacle.

Intralox offers scrolls in two nominal diameters: 6 in. (152 mm) and 9 in. (229 mm). Flight pitch, the axial distance for the flight to sweep through a full circle, is also 6 in. (152 mm) and 9 in. (229 mm), respectively. Since the scroll is also supporting the idle end of the belt, each nominal diameter has an associated minimum scroll length to ensure proper belt support. For very narrow belts, or for extra support, a double-flighted scroll is available. All scrolls are mounted on a 2.5 in. (63.5 mm) diameter round shaft. Maximum journal diameter is 2.5 in. (63.5 mm) and minimum journal length is 2 in. (50.8 mm).

SCROLL DIMENSIONS, in. (mm)			
Nominal Diameter	Actual Diameter	Min. Single-Flighted Scroll Length ^a	Min. Double-Flighted Scroll Length ^a
6 (152)	6.7 (170)	12.5 (318)	6.5 (165)
9 (229)	9.7 (246)	18.5 (470)	9.5 (241)

a. Exclusive of Journals.

Intralox scrolls are offered in carbon and stainless steel materials. Carbon steel scrolls are treated and painted for protection. All scrolls have a thick section of UHMW wearstrip attached to the flight edges. Stainless steel scrolls with a polished weld bead are available for USDA-FSIS applications.

Scrolls from Intralox may be used in applications where excessive amounts of debris may hamper the performance of sprockets or possibly damage the belt.

Position the scroll idler assembly in the conveyor frame so the "V" at the center of the scroll (where the left and right flights meet) points in the direction of belt travel. Adjust the shaft take-ups, if there is one, to have even tension on both sides.

SCROLL FEATURES	Flight Material		
	Carbon Steel	Stainless Steel	Stainless Steel USDA-FSIS
6 in. (152 mm) Scroll Size	•	•	•
9 in. (229 mm) Scroll Size	•	•	•
Intermittent Welds	•	•	
Continuous, Polished Welds			•
UHMW Flight Edging	•	•	•
Primer Gray Paint	•		

Intralox scrolls have no built-in tracking ability. It may be necessary to use side mounted wearstrips on the idle end.

WEARSTRIPS

FLAT WEARSTRIPS

STANDARD FLAT WEARSTRIPS are available in UHMW (Ultra High Molecular Weight), HDPE (High Density Polyethylene) and Nylatron (a Molybdenum-filled nylon). UHMW and HDPE wearstrips measure 0.25 in (6 mm) thick × 1.25 in (32 mm) wide × 120 in (3048 mm). Nylatron wearstrips measure 0.125 in (3 mm) thick × 1.25 in (32 mm) wide × 48 in (1219 mm). UHMW and HDPE wearstrips are FDA and USDA-FSIS compliant for direct food contact. Nylatron wearstrip is not FDA or USDA-FSIS accepted for food applications.

FLAT FINGER-JOINT WEARSTRIPS have a notched end design which provides overlapping sections for continuous support. UHMW wearstrips are available in 24 in (610 mm) and 60 in (1524 mm) lengths. HDPE wearstrip is available in 24 in (610 mm) lengths. Fasteners are supplied.

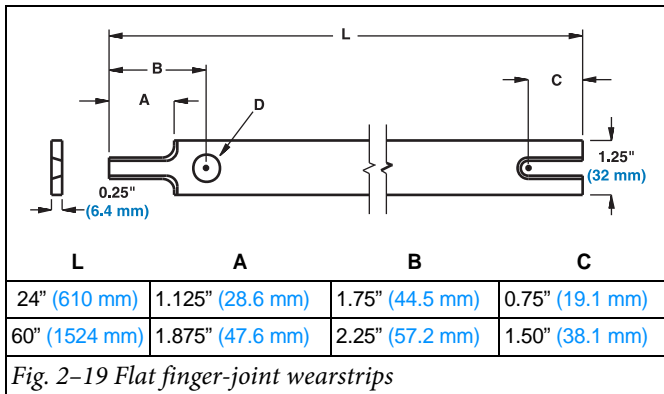
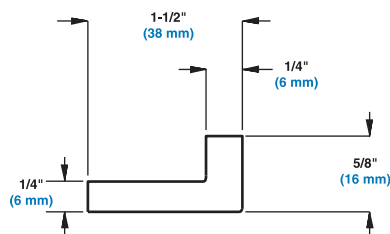

Fig. 2-19 Flat finger-joint wearstrips

ANGLE AND CLIP-ON WEARSTRIPS

Intralox also offers a variety of angle and clip-on wearstrips. All of the clip-on wearstrips styles come in 120 in (3048 mm) lengths. These wearstrips are designed to attach directly to the conveyor frame without fasteners.



STANDARD ANGLE WEARSTRIP (B6XX21IXXWMV-00)

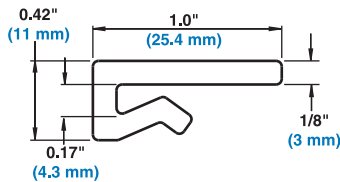

CLIP-ON (B6XX25IXXWMV-00)

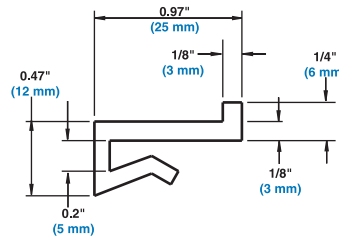

CLIP-ON WITH LEG (B6XX26IXXWMV-00)

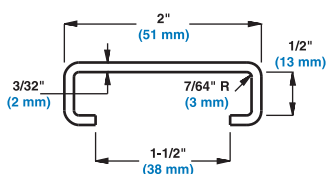

GUIDE RAIL SNAP-ON (B6XX27IXXWMV-00)

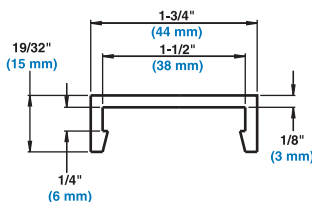

BARBED CLIP-ON (B6XX23IXXWMV-00)

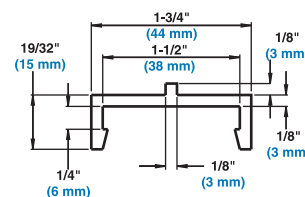

BARBED CLIP-ON WITH LEG (B6XX24IXXWMV-00)

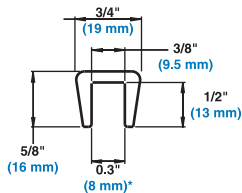

STANDARD BAR SNAP-ON (B6XX28IXXWMV-00)
*min. (toe in)

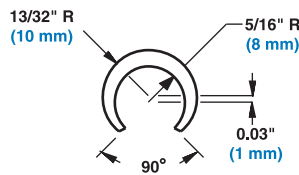

FULL ROUND SNAP-ON (B6XX29IXXWMV-00)

Fig. 2-20 UHMW Specialty wearstrips

STAINLESS STEEL BACKED UHMW WEARSTRIP

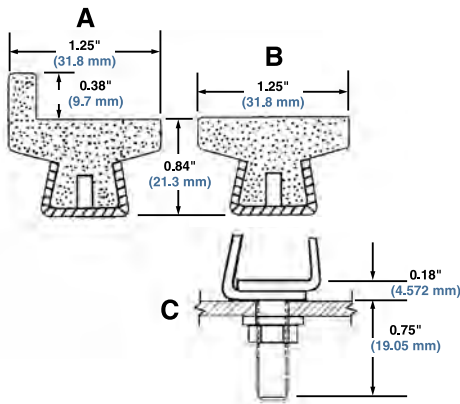

- A - "L" 120" STAINLESS STEEL BACK UHMW WEARSTRIP (B6XX43IXXWMV-00)
- B - "T" 120" STAINLESS STEEL BACK UHMW WEARSTRIP (B6XX42IXXWMV-00)
- C - SELF TIGHTENING STAINLESS STEEL WEARSTRIP CLAMP WITH NUT -5/16-18 UNC (C9AX1XXXXXXX-01)

Fig. 2-21 Stainless steel backed UHMW wearstrips

- Stainless steel backed UHMW wearstrip can be used to create a rigid belt carryway surface on any frame with cross members.

- Stainless steel backed UHMW wearstrip is mounted to cross members with a self tightening stainless steel clamp with nut (self tightening stainless steel clamp with nut sold separately).
- Can be installed in parallel, chevron or other configurations.
- Recommended for temperatures up to 160°F (71°C).
- Available in two profiles: Flat Wearstrip ("T") and "L" Wearstrip
- Available in 120 in. (3048 mm) lengths.
- Installation of wearstrips should allow for thermal expansion and contraction.
- Always chamfer or bend down the leading edges of any wearstrip.

UHMW PRESSURE SENSITIVE TAPE

Intralox offers UHMW self-adhering wearstrip tape in rolls of 54 ft. (16.5 m). This tape can be used for quick and easy conversion of steel wearstrips to a lower friction UHMW wearstrip. The 1 in. (25.4 mm) wide and 2 in. (50.8 mm) wide tape is available 0.010 in. (0.25 mm) and 0.030 in. (0.76 mm) thick.

Note: UHMW pressure sensitive tape is only to be used in light duty applications and temporary solutions.

CUSTOM WEARSTRIPS

RADIUS BELT WEARSTRIPS

All of the Radius Belt wearstrips are available in natural UHMW and self-lubricating, grey, oil-filled UHMW. The

Angle and Center Rail wearstrips utilize the EZ Clean design. All wearstrips are available in either 1/8 in. (3.2 mm) or 3/16 in. (4.7 mm) sizes. S2400 available in UHMW only

SECTION 2

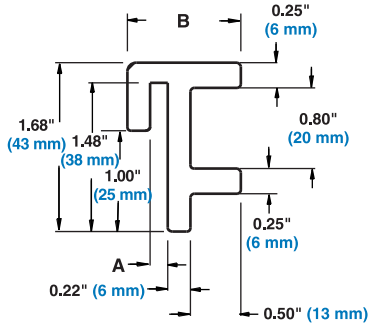

STANDARD EDGE, HOLD DOWN WEARSTRIP

UHMW - 1/8" (3.2 mm) - (B6XX331XXWMV-00) 3/16" (4.7 mm) (B6XX321XXWMV-00).

Oil-filled UHMW - 1/8" (3.2 mm) - (B6XX331XXWMW-00) 3/16" (4.7 mm) (B6XX321XXWMW-00).

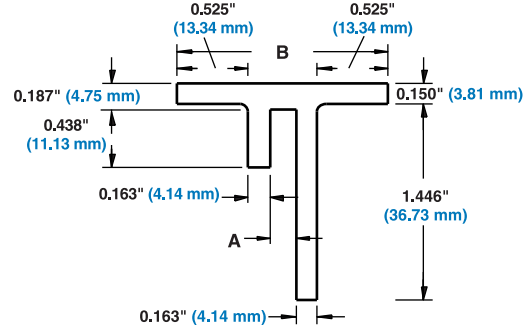

RADIUS BELT WEARSTRIP, CENTER RAIL HOLD DOWN WEARSTRIP

UHMW - 1/8" (3.2 mm) - (B6XX411XXWMV-00) 3/16" (4.7 mm) (B6XX401XXWMV-00).

Oil-filled UHMW - 1/8" (3.2 mm) - (B6XX411XXWMW-00) 3/16" (4.7 mm) (B6XX401XXWMW-00).

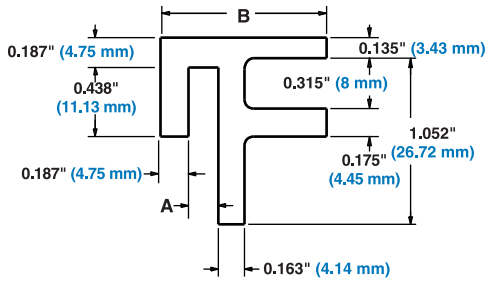

TABBED EDGE, HOLD DOWN WEARSTRIP

UHMW - 1/8" (3.2 mm) - (B6XX391XXWMV-20) 3/16" (4.7 mm) (B6XX381XXWMV-10).

Oil-filled UHMW - 1/8" (3.2 mm) - (B6XX391XXWMW-00) 3/16" (4.7 mm) (B6XX381XXWMW-00).

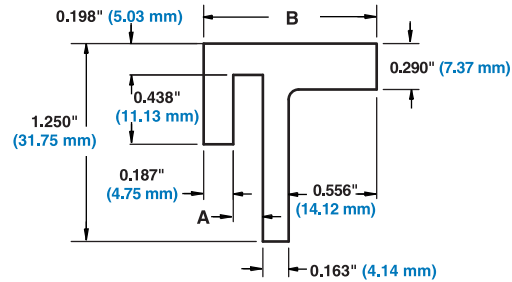

RADIUS BELT WEARSTRIP, SERIES 2400, HOLD DOWN GUIDE WEARSTRIP

UHMW - 1/8" (3.2 mm) - (B6F5461XXWMV-00) 3/16" (4.7 mm) (B6F5471XXWMV-00).

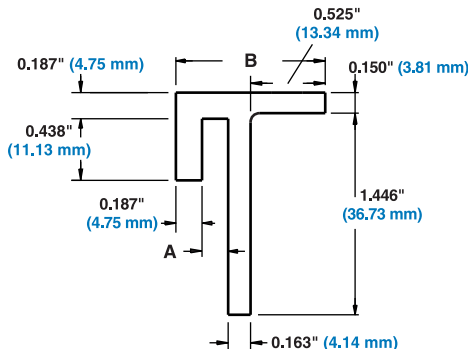

RADIUS BELT WEARSTRIP, ANGLE HOLD DOWN WEARSTRIP

UHMW - 1/8" (3.2 mm) - (B6XX371XXWMV-00) 3/16" (4.7 mm) (B6XX361XXWMV-00).

Oil-filled UHMW - 1/8" (3.2 mm) - (B6XX371XXWMW-00) 3/16" (4.7 mm) (B6XX361XXWMW-00).

Wearstrip Dimensions			
		A (Nominal)	
		1/8" (3.2 mm)	3/16" (4.7 mm)
B	Standard Edge	1.00" (25.4 mm)	1.13" (29 mm)
	Tabbed Edge	1.00" (25.4 mm)	1.06" (27 mm)
	Angle	1.00" (25.4 mm)	1.06" (27 mm)
	Center Rail	1.56" (40 mm)	1.56" (40 mm)
	S2400 Hold Down Guide	1.03" (26 mm)	1.09" (28 mm)

Fig. 2-22 120" UHMW RADIUS BELT CUSTOM WEARSTRIPS

PUSHER BARS

Accumulation tables are most often used in the beverage industry, allowing upstream production machinery to operate continuously and economically in the event that some downstream machinery stops the flow of the product. These tables act as a buffer to absorb the product overflow until the downstream problem is rectified. The principal function of a pusher bar is to move the last few rows of product off the accumulation table, past the dead plate area and onto the primary conveyor lines. Pusher bars rest on the accumulation table, which must use a Raised Rib style belt (Series 100, 400, and 900).

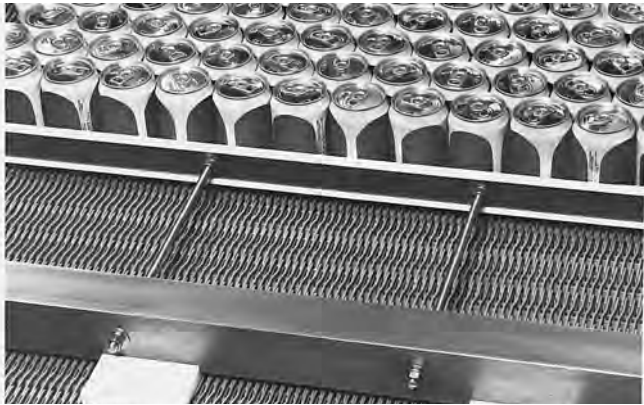

Fig. 2-23 Pusher bar side view

The bar is a 2.5 in (63.5 mm) square stainless or carbon steel shaft which rides in a number of slotted UHMW guide shoes. The shoes are slotted on the bottom to mesh with the ribs of the belt and keep the bar aligned, perpendicular to the direction of belt travel. The shoes bear the entire weight of the pusher bar, so it is recommended that wearstrips be placed to support the belt directly under the shoes.

The blade of the pusher bar actually does the pushing. It can be specified in 24 in (610 mm) to 120 in (3048 mm) lengths and consists of a rigid steel bar capped with UHMW wearstrip, so as not to mar or damage the product. The blade is set off from the weighted shaft by threaded steel rods, making the amount of offset adjustable to individual needs.

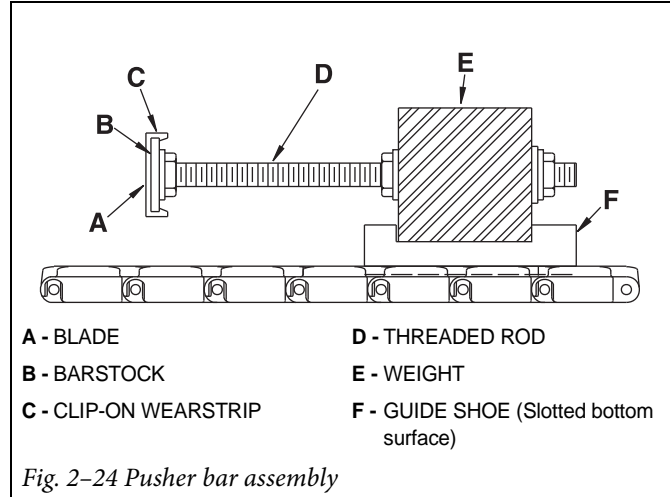

Fig. 2-24 Pusher bar assembly

A dual blade pusher bar is also available for tall or contoured products. The upper blade of this configuration is adjustable up and down and can be extended past or retracted further back from the lower blade.

Adjustment of the pusher bar is dependent upon: 1) placement of the device which limits the pusher bar's forward travel, and 2) dimensions of the product being conveyed. Standard offset is approximately equal to the length of the finger plate to be used: 5.75 in (146 mm) for Series 100, 7.5 in (191 mm) for Series 400 and 6.5 in (165 mm) for Series 900.

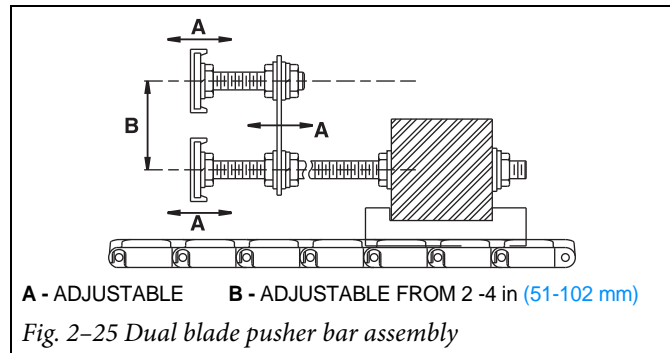

Fig. 2-25 Dual blade pusher bar assembly

SECTION 2

DEAD PLATES

Intralox offers UHMW dead plates with operating temperature limits of -100 °F (-73 °C) to 180 °F (82 °C).

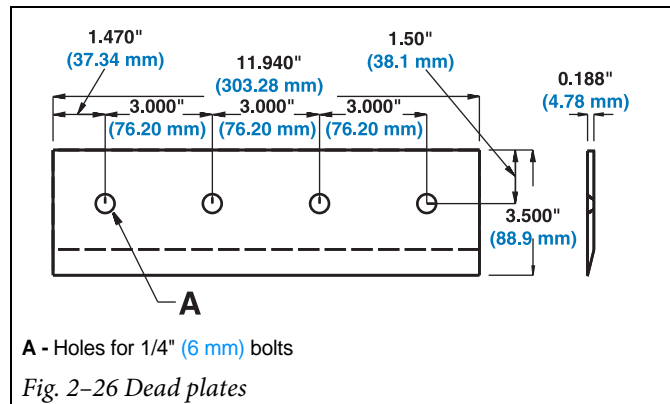

Fig. 2-26 Dead plates

EZ CLEAN IN PLACE SYSTEM (CIP)

Compatible with most conveyors, Intralox's new EZ Clean In Place (CIP) System cleans belts quickly, effectively, and consistently while minimizing water usage.

Intralox's new EZ Clean In Place System features a spray bar optimally located to increase and expedite debris removal, plus a custom-engineered spray pattern designed to thoroughly clean the belt underside, sprockets, and shaft. The system mounts within the conveyor frame behind the conveyor shaft and sprays the belt at 3 separate locations. Fan nozzles spray through the open belt hinges below and above the shaft as the belt travels around the sprockets. High impact nozzles spray the belt underside along the belt drive bars to maximize the debris channeling effect built into Intralox's EZ Clean belts. Cleaning is further optimized when used in conjunction with Angled EZ Clean sprockets.

The CIP can be installed on drive or idle end (drive preferred). It is made of 303/304 stainless steel, with highly polished surfaces. The minimum water pressure recommended at the intake of the CIP system is 150 PSI (10 bar).

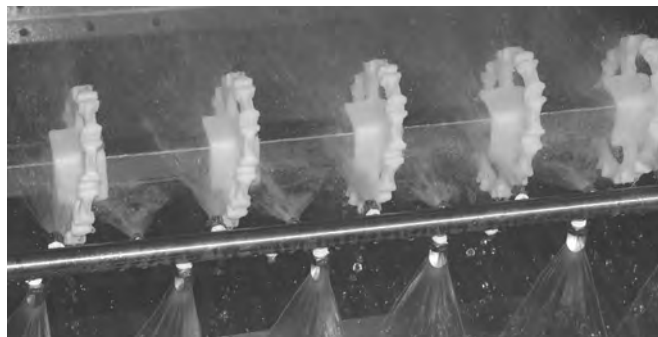

HOLD DOWN ROLLERS

Hold down roller assemblies can be used in place of hold down shoes or rails on wide elevating conveyors. On typical elevating conveyors, the flights have a notch in the center of the belt so that a hold down rail or shoe can be used to keep the belt on the conveyor frame. Product loss or damage from these shoes is an inevitable side effect.

Standard roller assemblies have a bracket made of acetal, with polypropylene rollers and rods, and are available for the following belt styles:

Series 200 — Flush Grid, Open Grid, Open Hinge, Flat Top, and Perforated Flat Top

Series 400 — Flush Grid, Open Hinge and Flat Top

Series 800 — Flat Top, Perforated Top, Flush Grid, and Mesh Top.

Hold down roller assemblies are built securely into the underside of the belt, held in place by the belt's hinge rods. The rollers ride in tracks that anchor the belt in position as it enters the incline of the conveyor. These assemblies can also be used in place of traditional hold down rails or shoes on the side of the conveyor.

Hold down rollers can be placed as frequently as every other belt row, a minimum of 4 in. (102 mm) apart to a recommended maximum of 24 in. (610 mm) apart. Normally,

8 in. (203 mm) spacing, every fourth row is sufficient. Sprocket size is limited by the rollers protruding from the bottom surface of the belt. In order to keep the rollers from coming into contact with the shaft, when using a 1.5 in. (or 40 mm) square shaft, the minimum allowable sprocket pitch diameter is 6.4 in. (163 mm). When using a 2.5 in. (or 60 mm) shaft, the minimum sprocket pitch diameter allowable is 7.7 in. (196 mm). Refer to "Section three: Design guidelines" (page 423), for more detailed information.

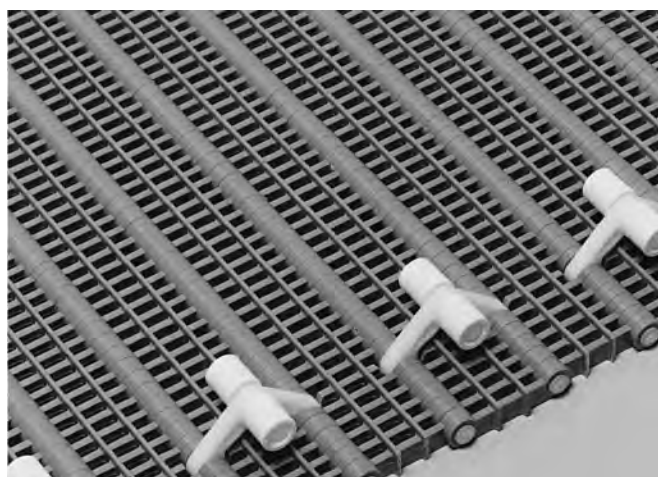

ABRASION RESISTANCE SYSTEM

Excessive rod and sprocket wear in abrasive applications can cause a number of undesirable conditions. Aside from the obvious effect of reduced belt life, there can be added difficulties in making repairs. A badly worn rod cannot be removed easily. Often, belt modules are damaged in the process. Worn rods also cause belt pitch to increase, which decreases sprocket engagement and, in turn, increases the wear rate on sprocket teeth. The belt may not run as smoothly as it should under these circumstances.

Intralox has developed stainless steel split sprockets and Abrasion Resistant (AR) hinge rods which enhance the performance of Intralox belts in abrasive or gritty environments. Rigorous testing shows that these AR components significantly outlast standard components and increase belt module life. Abrasive particles are less likely to

become imbedded in the harder AR material. Thus, the components themselves do not become abrasive surfaces wearing on the belt.

SPLIT SPROCKETS

Intralox Split Sprockets are an alternative to molded plastic sprockets for all Series 100, 400, 800, 900, 1100, 400, 800, 900, 1100, and 1200 belts. Split Sprockets are constructed from FDA compliant materials, but are not USDA-FSIS accepted. Refer to the individual Shaft and Sprocket Data pages for detailed information.

The old style, all Stainless Steel Abrasion Resistant Sprockets, are still available as special order items. Contact Customer Service for lead-times.



Fig. 2-27 Split sprockets

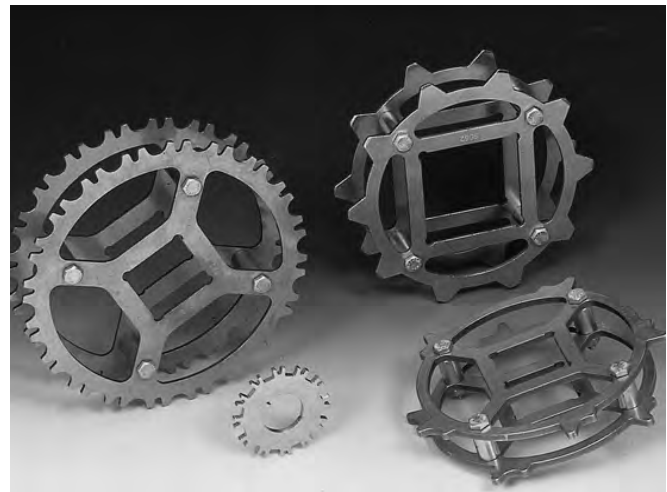

Fig. 2-28 Abrasion resistant (all steel) sprockets

ABRASION RESISTANCE HINGE RODS

The AR rods are stiffer than standard rods, so belt pull capabilities are not sacrificed. They are lighter, less expensive and are more flexible than steel rods. They also provide good chemical resistance, low friction, a wide operating temperature range and are FDA compliant for direct food contact.

In all belt styles which employ Intralox's snap-lock rod retention system, the AR rods are held in place with "rodlets" installed on both edges of the belt. Rodlets are short, headed rods (see "Fig. 2-29 Abrasion resistant rods and rodlets") which are also made of Abrasion Resistant material.

Belts that utilize a headless rod retention system or belts with SLIDELOX® do not require a head of any type (see below "Fig. 2-30 Series 1100 side view" and "Fig. 2-31 Series 1400 with Slidelox®").



Fig. 2-29 Abrasion resistant rods and rodlets

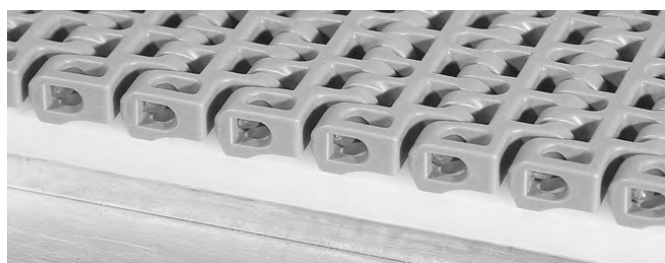

Fig. 2-30 Series 1100 side view



Fig. 2-31 Series 1400 with Slidelox®

SERIES	STYLE	ROD RETENTION SYSTEM
100	All Styles	Snap-Lock Rodlets
200	All Styles except Open Hinge	Thermally Deformed Rod Hole
400	All Styles except Open Hinge	SLIDELOX® - FG & RR Snap-Lock Rodlets - Flat Top Headless - Angled Roller
800	All Styles	Snap-Lock Rodlets
850	All Styles	Snap-Lock Rodlets
900	All Styles	Snap-Lock Rodlets
1000	All Styles	Series 1000 Headless
1100	Flush Grid	Series 1100 Headless
1200	All Styles	SLIDELOX®
1400	Flat Top	SLIDELOX®
1500	All Styles	Series 1500 Headless
1600	All Styles	Series 1600 Headless
1650	All Styles	Series 1600 Headless
1700	All Styles	SLIDELOX®
1800	Flat Top	Series 1800 Headless
1900	All Styles	Shuttleplug™
2200	Flush Grid	Series 2200 Headless
2400	Flush Grid	Series 2400 Headless
2600	All Styles	Series 2600 Headless
2700	All Styles	Series 2700 Headless
2800	All Styles	Series 2800 Headless
9000	All Styles	Series 9000 Headless

The SLIDELOX® rod retention system is a headless rod retention method. This system uses a shuttle plug to retain the rods during operation. The SLIDELOX® plug can be easily moved to the side when work on the belt is required.

To remove a rod after a belt has been in service for some time, apply a soapy solution or other lubricant to the belt hinge. This will help loosen any grit that has become trapped between the rod and the module.

If Abrasion Resistant rods are used in continuously wet, elevated temperature environments, they have a tendency to absorb water and expand in length and diameter. If an application requires an Abrasion Resistant rod in these conditions, contact Sales Engineering to determine the approximate expansion due to water absorption.

EZ MOUNT FLEX TIP SCRAPER

EZ Mount Flex Tip Scraper				
Available Height		Available Length		Available Materials
in	mm	in	mm	
2.75	70	72	1830	rigid PVC base with flexible polyurethane tip
<p>Note: Available in only one size</p> <p>Note: Should be cut to length upon receipt</p> <p>Note: Designed for wet or greasy product applications</p> <p>Note: Not for use with dry products or applications</p> <p>Note: FDA compliant</p>				

SECTION THREE: DESIGN GUIDELINES

After selecting a belt (series, style and material) and its accessories, the conveyor frame must be designed. Intralox provides the following dimensional data and guidelines, based upon good design principles and practice, for use in designing new conveyor frames or adapting and retrofitting existing ones.

The illustration below identifies most of the components in a conventional, horizontal conveyor. The items shown are only

representative of those in common use. There are many variations of components and design details. The designer must become familiar with those available in order to produce the most appropriate and economical conveyor.

Contact Customer Service to request the **Conveyor Belting Installation, Maintenance & Troubleshooting Manual** or to request any additional guidelines.

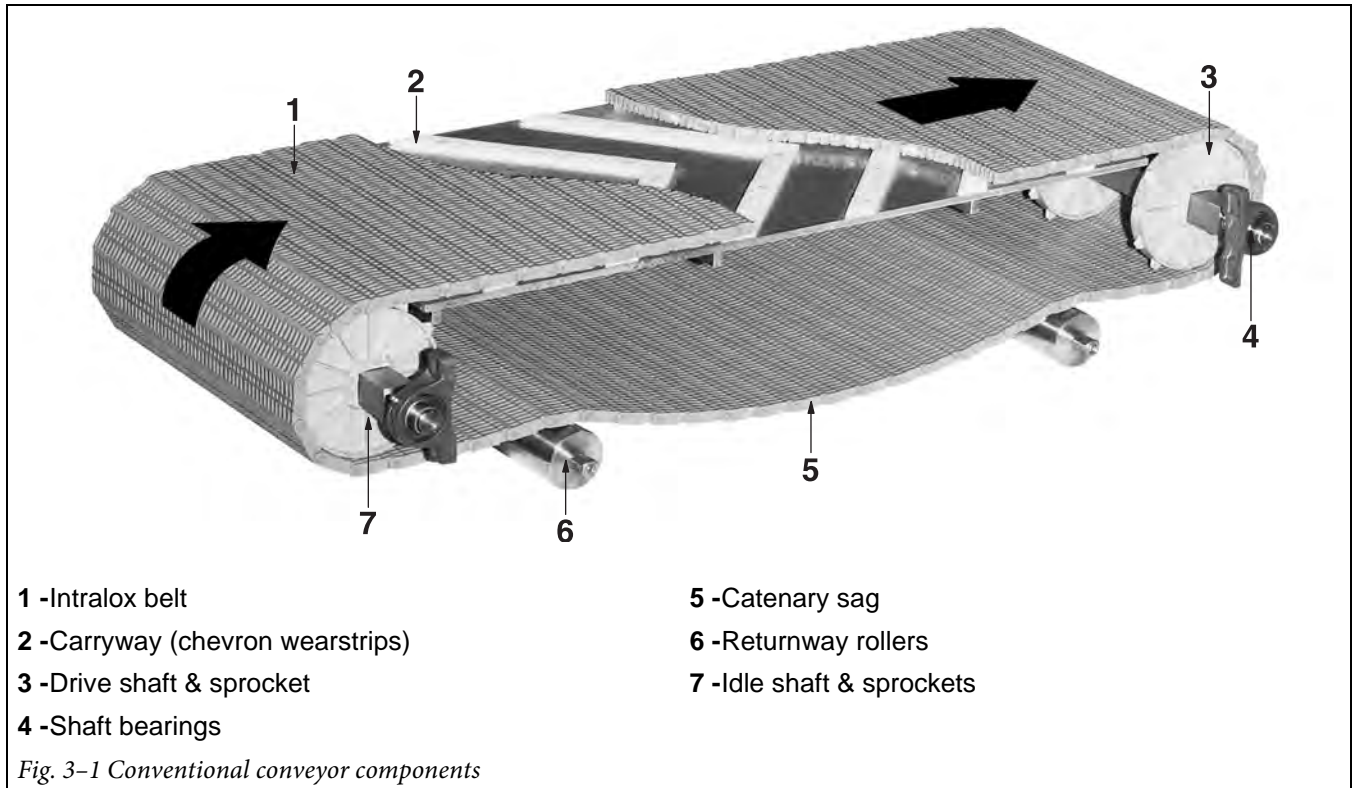

SECTION 3

BASIC CONVEYOR FRAME REQUIREMENTS

Regardless of type or configuration, all conveyors using Intralox belts have some basic dimensional requirements. Specifically, dimensions "A", "B", "C", "D" and "E" in the illustrations and tables below should be implemented in any

design. Also, the conveyor should allow access to the side of the belt at some point for rod clearance during the installation, tensioning, or removal of the belt.

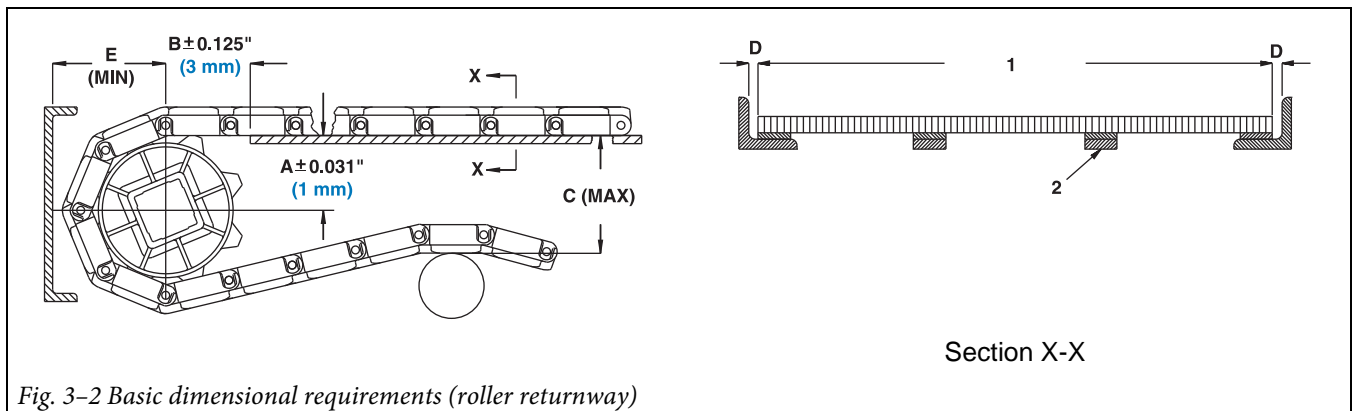

Section X-X

DIMENSION DEFINITIONS

A — The vertical distance between the centerline of the shaft and the top of the carryway.

The belt-to-sprocket engagement and end-off/end-on product transfers are affected by the “A” dimension and the amount of chordal action between the belt and sprockets. Chordal action occurs as each row of modules in a belt rises and falls as it engages the drive sprockets or disengages the idle sprockets. This effect is most pronounced in the large pitch belt/small pitch diameter sprocket combination, such as **Series 800** with 4.0 in. (102 mm) pitch diameter sprockets.

For small pitch diameter sprockets, the “A” dimension is given as a range to indicate when the belt will be horizontal at both the high and low points of the chordal action.

For large pitch diameter sprockets/small pitch belt combinations, the effects of chordal action are small and fall within the allowable tolerance. For these sprockets, a range for the “A” dimension is not necessary.

The bottom of the range is determined when the center of the module is at the top of the sprocket. At this point, this leading, engaged module is horizontal (“Fig. 3-3 Chordal effects - bottom of range”). As this row of modules rotates around the sprocket, the next row starts engaging the sprockets and is lifted above horizontal. It returns to horizontal as this row fully engages the sprockets.

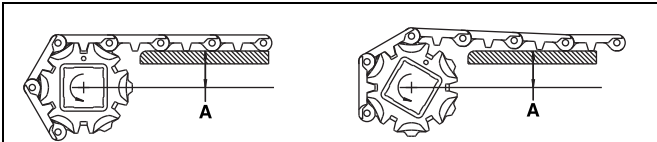

The row of engaging modules is raised above horizontal when the center of the hinge is at the top of the sprocket, but returns to horizontal as the center of the module passes the center of the sprocket.

Fig. 3-3 Chordal effects - bottom of range

For general applications and applications where end transfer of tip-sensitive product is not critical, use the “A” dimension at the bottom of the range.

The top of the range is determined when the center of the hinge, between two rows of modules, is at the top of the sprocket. At this point, the leading module is horizontal (“Fig. 3-4 Chordal effects - top of range”). As this row of modules engages the sprockets, the row drops below horizontal. It returns to horizontal as the leading edge of the next row starts to engage the sprockets. This arrangement should not be used with **Series 800** belts since the underside

geometry of the modules may cause chatter, noise, and wear on the ends of the wearstrip or wear plate.

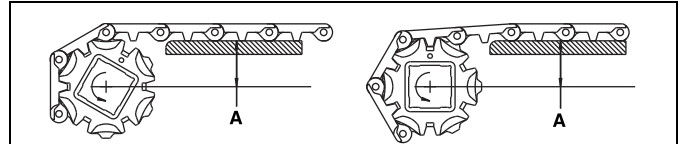

The row of engaging modules is horizontal when the center of the hinge is at the top of the sprocket, but goes below horizontal as the center of the module passes the center of the sprocket.

Fig. 3-4 Chordal effects - top of range

The “A” dimension can be set at any point inside the given range. If an “A” dimension is selected, which is between the top and bottom of the range, the belt will both rise above horizontal and drop below horizontal as each row engages the sprockets.

B — The horizontal distance between the centerline of the shaft and the beginning of the carryway. This dimension assumes that a 0.5 in. (12.7 mm) thick carryway is used, allowing for a typical 0.25 in. (6.4 mm) support and 0.25 in. (6.4 mm) wearstrip. The carryway can be extended to within 0.5 in. (12.7 mm) of the centerline of the shaft if the supports extend between the sprockets “Fig. 3-10 Anti-sag configuration” (page 428).

C — The vertical distance between the top of the carryway and the top of the returnway rails or rollers. This should provide between 180° (min.) and 210° belt wrap around the drive sprockets. The listed dimensions will provide the minimum 180° wrap required by most belts for proper engagement.

Some exceptions are **Series 1700**, which requires a maximum of 180° of belt wrap, and **Series 550**, which requires no more or no less than 180° of belt wrap.

D — The clearance between the edges of the belt and the side frame member, 0.25 in. (6.4 mm) min. **It should be noted that the minimum edge clearance between side frames and the belt must be determined at the operating temperature of the belt. Always check with Customer Service for precise belt width measurement and stock status before designing a conveyor or ordering a belt.** See “THERMAL EXPANSION AND CONTRACTION” (page 443) and “EXPANSION DUE TO WATER ABSORPTION” (page 443) sections to calculate the operating width of your belt at temperatures above ambient.

E — The minimum horizontal distance between the centerline of the shaft and any framework.

DRIVE GUIDELINES

Intralox square shafts provide maximum efficiency in driving the belt. The two primary advantages are: 1) the positive transmission of torque to the sprockets without keys and keyways, and 2) allowing lateral movement of sprockets to accommodate the inherent differences in thermal expansion or contraction between plastics and metals.

SHAFT SIZES AND MATERIALS

Intralox, LLC USA stocks square shaft materials in Aluminum (6061-T6), Carbon Steel (C-1018) and Stainless Steel (303/304 and 316) in the following sizes:

- Aluminum: 1 in. and 1.5 in.
- Carbon Steel: 5/8 in., 1 in., 1.5 in., 2.5 in., 3.5 in.
- 303/304 Stainless Steel: 5/8 in., 1 in., 1.5 in., 2.5 in., 40 mm and 60 mm
- 304 HR Stainless Steel: 3.5 in.
- 316 Stainless Steel: 1.5 in. and 2.5 in.

Intralox, LLC Europe offers square shaft materials in Carbon Steel (KG-37) and Stainless Steel (304) in the following sizes:

- Carbon Steel: 25 mm, 65 mm and 90 mm.
- Stainless Steel: 25 mm, 40 mm, 60 mm, 65 mm and 90 mm.

The correct shaft size for your application can be determined by calculations found in the “Belt Selection Instructions” (page 20), or from the formulas beginning on page 446. Typical shaft sizes and material properties are listed in “Table 8 SHAFT DATA” (page 457).

Note: Inform Customer Service if shaft will be used in a Hollow Gear Box.

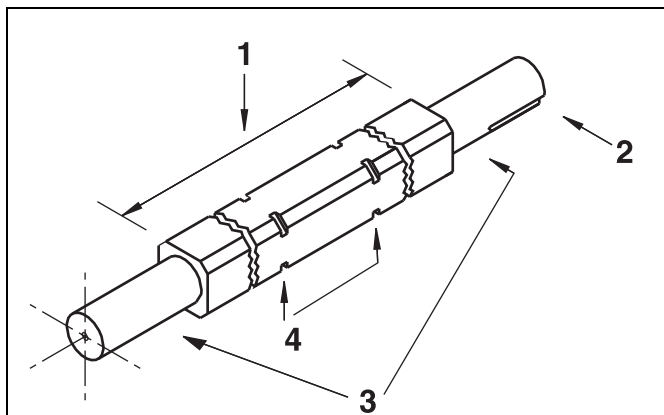

- 1 - Square section length [Distance between bearings, less 1/4 in. (6 mm)]
- 2 - Keyway for driver hub (not required on idle shaft)
- 3 - Bearing journals
- 4 - Retainer ring grooves

Fig. 3-5 Typical shaft features

DRIVE SHAFT TORQUE LOADING

An important consideration in the selection of shaft sizes is the torque loading that the drive shaft must absorb. The belt’s pull, acting through the sprockets, introduces the torsional or twisting load on the drive shaft. Under any given set of conditions, i.e., product loading and frictional resistance, the belt pull will remain constant, but torque on the drive shaft will vary with the size of sprockets chosen. *As the sprocket pitch diameter is increased, the torque on the shaft is also increased.* Therefore, if a particular shaft size is desired, but the torque to be absorbed exceeds that recommended by “Table 9 MAXIMUM RECOMMENDED TORQUE ON DRIVE SHAFT” (page 457), recalculate the torque with the smaller sprocket if there is a smaller diameter sprocket available in your belt’s series. To achieve the same belt speed, the rotational speed (RPM) must be proportionally greater with the smaller sprocket.

POWER REQUIREMENTS

The power needed to drive the belt can be calculated in the “Belt Selection Instructions” (page 20), or from the formulas beginning on page 446. It should be noted, this calculated power does not include the power needed to overcome mechanical or other inefficiencies in the system. Since conveyor arrangements and power trains may consist of many possible choices, the following table may assist you in determining the amount of added power needed for your design.

MACHINERY ELEMENTS AVERAGE MECHANICAL EFFICIENCY LOSSES

Ordinary Sleeve Bearings	2% to 5%
Ball Bearings	1%
Gear Reducers:	
Spur or Helical Gears	
Single Reduction	2%
Double Reduction	4%
Triple Reduction	5%
Worm Gears	
Single Reduction	5%
Double Reduction	10% to 20%
Roller Chains	3% to 5%
V Belts	2% to 4%
Hydraulic Power Systems	(consult manufacturer)

Determine the total efficiency losses in the components to be used and use the calculated power to determine the required **Motor Power** as follows:

$$\text{Motor Horsepower} = \frac{\text{Belt drive power}}{100\% - \text{Total \% Losses}} \times 100$$

For example, if you determine the total efficiency losses in your system amount to 15% and your belt drive power was calculated to be 2.5 horsepower, the required motor horsepower can be found from:

$$\text{Motor Horsepower} = \frac{2.5}{100 - 15} \times 100 = 2.94$$

Therefore, in this case, the appropriate motor power to drive this system would be 3 horsepower.

RETAINING SPROCKETS

It is usually necessary to *laterally retain only one sprocket* on each of the drive and idler shafts. This sprocket will provide the positive tracking necessary to keep the belt running properly between side frames of the conveyor. By allowing the other sprockets to move laterally, thermal expansion differences between the belt and frame are easily accommodated. By convention, Intralox recommends the sprocket adjacent to or on the belt's centerline be retained using retainer rings on both sides of the sprocket. When only two sprockets are used, retain the sprockets on the drive journal side of the conveyor.

In some cases, the "center" sprocket will be slightly offset from the centerline of the belt. Ensure the locked sprockets on the idle and drive shaft are aligned on the shafts. If a Radius Belt Standard Edge or Tabbed Edge wearstrip is used to contain the **Series 2200** belt up to the sprockets, it is not recommended that any sprockets be retained on the shaft. In this case, the wearstrip is used to maintain the belt's lateral position.

INTERMEDIATE BEARINGS

On wide belt systems or those under heavy tension loads, an additional bearing (or bearings) may be needed to support the center of the drive and idler shafts to reduce deflection to acceptable levels. Excessive drive shaft deflection will cause improper belt-to-tooth engagement, a condition which should be avoided.

When intermediate bearings are considered, the shaft deflection formulas are different from the one which applies to shafts supported by only two bearings. With a third bearing, *located in the center of the shaft*, the deflection formula (see page 448) is straightforward and easy to apply.

$$D_3 = \frac{1}{185} \times \frac{w}{2} \times \frac{L_S^3}{E \times I}$$

$$= \frac{w \times L_S^3}{370 \times E \times I}$$

- where: **D** = Deflection, in. (mm)
w = Total shaft load, lb (kg)
L_S = Shaft length *between bearings*, in. (mm)
E = Modulus of Elasticity, lb/in² (kg/mm²)
I = Moment of Inertia, in.⁴ (mm⁴)

However, *when the third bearing is placed off center, or when more than three bearings are used*, the analysis is so complicated that convenient general formulas for deflection cannot be given. A simpler approach is to allow the designer to determine a *safe maximum span length*, using the charts in Section 4. After calculating the **TOTAL SHAFT LOAD, w**,

the maximum span for available shaft sizes and materials is easily determined. **Tables 11A** and **11B** (page 459) are for Conventional Conveyors using two bearings and three or more bearings. **Tables 11C** and **11D** (page 459) are the corresponding curves for Bi-directional and Pusher Conveyors.

Intermediate bearings usually are Split Journal Bearings. They should be mounted on the conveyor frame with the split of the bearing housing perpendicular to the direction of the belt travel. (Note: if the split is parallel with the belt travel, its load capacity is reduced significantly.) In cases requiring intermediate bearings, it is prudent to utilize sprockets with the largest practical diameter because of the rather large housing dimensions. Otherwise, a bearing modification may be needed to allow it to fit the limited space available.

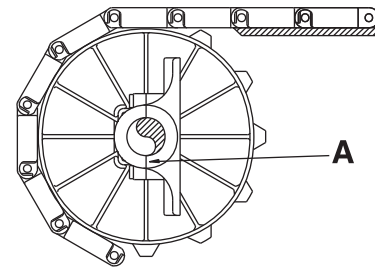

A - Split in bearing housing should be perpendicular to the direction of belt pull.

Fig. 3-6 Intermediate bearings recommended mounting arrangement

ROLLERS AS IDLE SHAFTS AND SPROCKET REPLACEMENTS

In many applications, idle shafts and their sprockets may be replaced by rollers, supported by stub shafts to account for roller deflection. These pipe rollers can be considerably stiffer than a comparable length of solid, square shafting. For example, a 4 in. (102 mm) — Schedule 40 pipe and a 6 in. (152 mm) — Schedule 40 pipe have more than twice the stiffness of 2.5 in. (63.5 mm) and 3.5 in. (88.9 mm) square steel shafts, respectively. Therefore, in cases where loads are high and the belt is wide, the use of rollers such as these may eliminate the need for intermediate bearings to reduce shaft deflection to acceptable levels. Flanging or spooling of the ends of the rollers to retain the belt laterally is necessary in some cases.

Scroll idlers can also be used in place of idle sprockets. See "Scroll idlers" (page 413). Scroll idlers are used to help keep the returnway clean and free of debris.

SOFT STARTING MOTORS AND FLUID COUPLINGS

Rapid starting of high speed or loaded conveyors is detrimental to good belt and sprocket life. This will also cause adverse effects on the entire drive train. When the motor power exceeds 1/4 horsepower per foot of belt width (612 watts per meter), Intralox strongly recommends the use of soft starting electric motors, Variable Frequency Drives (VFDs), or one of the several fluid couplings (wet or dry) presently available. These devices allow the driven conveyor to accelerate gradually to operating speeds (ramp up/ramp down), which is beneficial for all components.

BELT CARRYWAYS

Intralox belting can be supported in the load-bearing part of its travel by carryways of various arrangements. Since their primary purposes are to provide a lower friction running surface and to reduce wear on both the belt and the frame, it is wise to give careful consideration to this part of the design.

The carryway belt contact surfaces may be of metal, usually cold-rolled finished Carbon or Stainless Steel, or one of the commonly used plastics available from Intralox. Please refer to the belt data pages in “Section two: Product line” (page 9), or **Tables 2A** (page 454) and **2B** (page 454) for frictional characteristics of each. Also refer to the wearstrip data (beginning on page 445) for a description of the plastic strips available from Intralox.

SOLID PLATE CARRYWAYS

These are continuous sheets of metal, UHMW or HDPE over which the belt slides. They extend the full width of the belt and almost the entire length between idler and drive sprockets. The plates may be perforated with slots or holes to allow for drainage and the passage of foreign material. In heavily loaded applications, this type of carryway surface is considered a good choice because of the continuous support it provides to the belt. Contact the Technical Support Group for material recommendations.

WEARSTRIP CARRYWAYS

All wearstrips are available in Ultra High Molecular Weight (UHMW) Polyethylene. Certain styles are also available in High Density Polyethylene (HDPE) and Molybdenum-filled nylon (Nylatron).

Wearstrip types and sizes

Intralox can provide wearstrips of three different types:

- **Standard flat wearstrips** are relatively thick, narrow, flat bars of UHMW, HDPE or Nylatron. UHMW and HDPE flat wearstrips are available in 0.25 in. (6.4 mm) thick × 1.25 in. (31.8 mm) wide × 10 ft. (3 m) lengths. Molybdenum-filled nylon (Nylatron) flat wearstrips are available in 0.125 in. (3.2 mm) thick × 1.25 in. (31.8 mm) wide × 8.5 ft. (2.6 m) lengths. The strips are applied directly to the frame and attached with plastic bolts and nuts in slotted holes. This allows the strips to expand and contract freely with temperature changes.
- **Flat finger-joint wearstrips** have a notched-end design (“Fig. 3-7 Straight, parallel wearstrip arrangement”) which provides an overlapping section for continuous belt support without sharp edges. These 0.25 in. (6.4 mm) thick wearstrips are fastened in short lengths at the leading end only, with a 0.375 in. (9.5 mm) gap, to provide freedom for elongation caused by temperature changes. They are available in UHMW and HDPE.
- **Angle and clip-on wearstrips** normally are used in applications where belt edge protection is needed or lateral transfer is required. They are available in lengths of 10 ft. (3 m) in UHMW. In addition to the standard angle wearstrip,

several specially **clip-on** or **snap-on** strips are available. These strips attach to the frame without the need of fasteners. Refer to page 414 for more information on available wearstrips.

Wearstrip arrangements

- **Straight, parallel runners** These supports consist of strips, either metal or plastic, placed on the frame parallel with the belt’s travel. While relatively inexpensive to install, their disadvantage is that belt wear is confined to the narrow areas in contact with the strips. This arrangement is recommended, therefore, in low-load applications only.

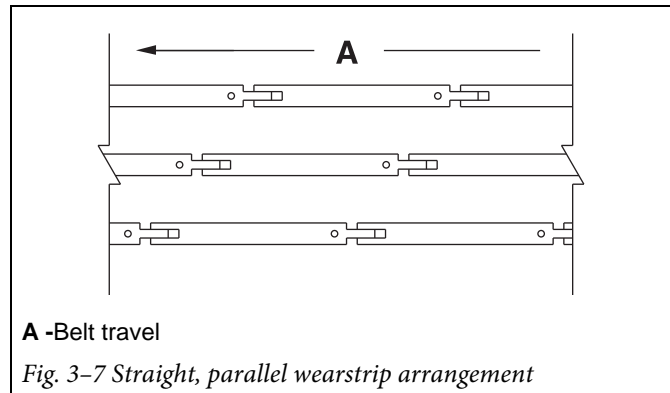

A -Belt travel

Fig. 3-7 Straight, parallel wearstrip arrangement

- **Chevron array** By placing the strips in an overlapping “V” or Chevron array, the underside of the belt is supported across its full width as it moves along the carryway. Thus the wear is distributed evenly. The angled surfaces can be effective in removing gritty or abrasive material from the underside of the belt. A minimum 0.4 in. (10.2 mm) gap is recommended between the points of the wearstrip to reduce debris build up. This arrangement is also good for heavily loaded applications. By reducing the spacing between adjacent chevrons, the bearing load on the strips and the belt’s unsupported span is decreased. Standard flat wearstrips can be modified to form the Chevron array.

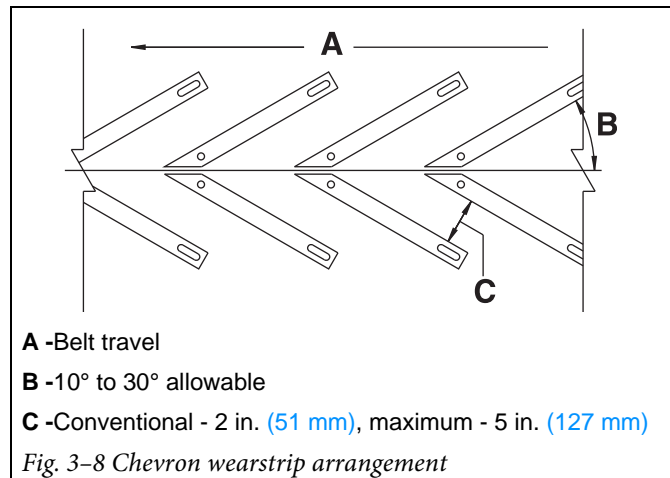

A -Belt travel

B -10° to 30° allowable

C -Conventional - 2 in. (51 mm), maximum - 5 in. (127 mm)

Fig. 3-8 Chevron wearstrip arrangement

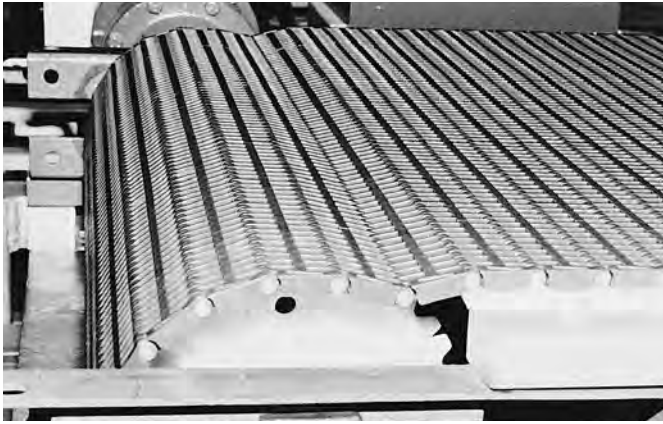

Fig. 3-9 Buckling belt rows

ANTI-SAG CARRYWAY WEARSTRIP CONFIGURATION

Under certain conditions, belts will require more carryway support near the sprockets. This is due to the belt tension not being great enough to support product between the end of the wearstrip support and the beginning of the sprocket support. Without adequate support, the belt may buckle (“Fig. 3-9 Buckling belt rows”). This buckling can be eliminated by extending the wearstrip supports, between the sprockets, to within 0.5 in. (12.7 mm) of the shaft centerline (“Fig. 3-10 Anti-sag configuration”).

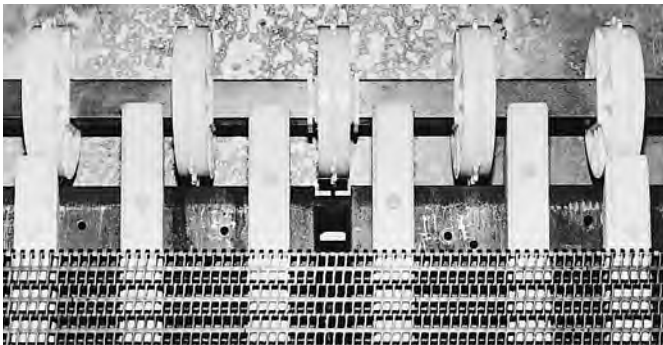

Fig. 3-10 Anti-sag configuration

Belts with a pitch of 1.07 in (27.18 mm) or smaller may need more support, with no more than 2 in (51 mm) of unsupported span. To prevent the belt from sagging or bowing under the weight, the wearstrips should be placed so that the unsupported spans between the strips, in parallel or chevron array, do not exceed 2 in. (50.8 mm). The unsupported span of 2 in. (50.8 mm) is measured perpendicular to the support structure (“Fig. 3-10 Anti-sag configuration”), regardless of the angle of the support to the direction of belt travel.

WEARSTRIP DESIGN CONSIDERATIONS

Temperature limits

UHMW flat and angle wearstrips are recommended to 160 °F (71 °C). HDPE is recommended to 140 °F (60 °C); Molybdenum-filled nylon (Nylatron) up to 250 °F (121 °C).

Thermal expansion and contraction

Installation of Intralox flat and angle wearstrips should allow for thermal expansion and contraction. See “THERMAL EXPANSION AND CONTRACTION” (page 443), for Coefficients of Expansion. At operating temperatures of 100 °F (38 °C) or less, it is sufficient to bevel-cut the opposing ends of strips at an angle of 30° from the horizontal and provide a clearance gap of 0.30 in. (7.6 mm). At temperatures exceeding 100 °F (38 °C), the angle of the cut should be 60°. The clearance should be determined from thermal expansion calculations. It is recommended that wearstrip joining locations be staggered for smooth belt operation.

Chemical resistance

Please refer to the Polyethylene columns of the “Chemical Resistance Guide” (page 461), for information on UHMW and HDPE wearstrips.

RETURNWAYS AND TAKE-UPS

The return side of conventional conveyors using Intralox belts are generally exposed to relatively low tension loads, but nonetheless, are very important in the overall design.

Note: On bi-directional and push-pull conveyors where return side tensions are high, special attention must be paid to this part of the design, see page 432.

CONTROL OF BELT LENGTH

One of the principal functions of the returnway is to properly accommodate the change in belt length while operating. Control of belt length is vital in maintaining sufficient tension after the belt disengages from the drive shaft sprockets. A belt which increases in length can disengage from its drive sprockets if proper design criteria are not followed. A belt which contracts due to cold temperatures may cause over-tensioning and excessive shaft loads if some surplus belt is not

provided. Belts will either elongate or contract in operation because of these factors:

- **Temperature variations**

Assuming belts are installed at average ambient conditions, normally about 70 °F (21 °C), any significant temperature change in operation will result in contraction or elongation of the belt. The magnitude of the thermal contraction or expansion is dependent upon the *belt’s material*, the *difference in temperatures* and the *overall belt length*. Please refer to the section on “THERMAL EXPANSION AND CONTRACTION” (page 443), to determine the temperature effects in your application.

- **Elongation (strain) under load**

All belts elongate if tension is applied. The amount of increase in length depends upon the belt *Series and Style*, the *belt’s material*, the *amount of tension* or “belt pull” applied, and the *operating temperature*. Generally, on conventional conveyors where the **ADJUSTED BELT PULL (ABP)** is

about 30% of **ALLOWABLE BELT STRENGTH (ABS)**, this load-induced elongation is approximately 1% of the conveyor's length. If **ABP** reaches the **ABS**, this strain should not exceed 2.5% of the conveyor's length.

- **Elongation due to break-in and wear**

New belts will usually experience elongation in the first days of operation as the hinge rods and modules "seat" themselves. In some severe services where heavy loads exist or abrasives are present, older belts will experience elongation due to wear of the hinge rods and enlargement of the modules' hinge rod holes.

CATENARY SAG

Due to elongation under load, temperature variations, and pitch elongation, catenary sag is required to ensure proper back tension and belt storage for Intralox belts with low tension. For applications that will experience a large amount of expansion in length, other take-up arrangements may be required. See page 431 for an explanation of these alternate arrangements.

BACK TENSION

An adequate amount of returnway tension is needed directly after the drive sprocket for proper belt-to-sprocket engagement. This tension is commonly referred to as **back tension**. The span length and depth of the first catenary sag section directly after the drive sprockets provide this back tension. Back tension is increased as the span is **increased** or as the depth is **decreased**. The depth of this catenary section should not be allowed to exceed the recommendations in the following illustrations for this reason. Care should also be

taken to avoid allowing the sagged belt to "bottom-out" on the conveyor frame. This will greatly reduce the back tension and may cause sprocket disengagement.

The roller directly after the drive sprocket, commonly referred to as a "snub" roller, should be placed so that the belt is wrapped between 180° and 210° around the drive sprockets (see the "C" dimension of "*Dimension definitions*" (page 424)).

In the design of conventional conveyors, it is seldom necessary to know precisely the amount of sag and tension required for good belt-to-sprocket engagement. In cases when catenary sag is used to accommodate belt length changes, it may be necessary to know the length of the additional or excess belt which is hanging between two adjacent supports and the tension created by that hanging section. These can be determined from formulas beginning on page 446. These simplified formulas give close approximations for predicting the results of catenary sag conditions. The actual formulas for catenary curves are more complex. However, in practice, where the span-to-sag ratio is large, these simpler formulas are sufficiently accurate for most applications. For example, with a span-to-sag ratio of 10 to 1, the error in the tension formulas is approximately 2%.

STANDARD RETURNWAYS

The following illustrations provide recommended returnway arrangements which have proven successful in many applications.

On very short conveyors, less than 6 ft. (2 m) long, a returnway support usually is unnecessary. The catenary sag between drive and idler sprockets alone is sufficient for good operation if the sag is limited to a maximum of 4 in. (102 mm).

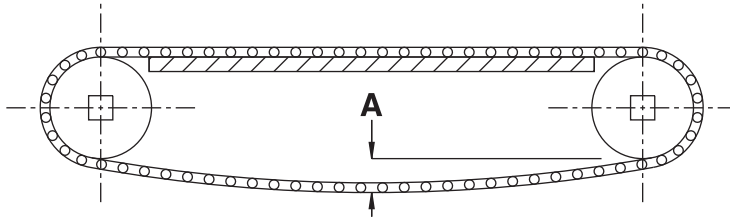

Fig. 3-11 Short conveyors (less than 6' [1.8 m])

A -The amount of catenary sag between each set of return rollers on longer conveyors or between the drive and idle sprockets on short conveyors should be between 1 in. (25.4 mm) and 4 in. (102 mm).

B -The snub roller should be placed 9 in. (229 mm) to 18 in. (457 mm) from the drive and idle shaft. The snub roller should be placed so that the belt has between 180° and 210° of wrap around the sprocket.

C -The returnway rollers should be spaced 36 in. (914 mm) to 48 in. (1219 mm) apart for all series belts except **Series 100 and 400**, which should have a 48 in. (1219 mm) to 60 in. (1524 mm) spacing. This, in combination with A and B, should provide the proper amount of return side tension for good sprocket engagement.

D -The minimum roller diameter is 2 in. (51 mm) for belts up to 1.07 in. (27 mm) pitch and 4 in. (102 mm) for larger pitch belts.

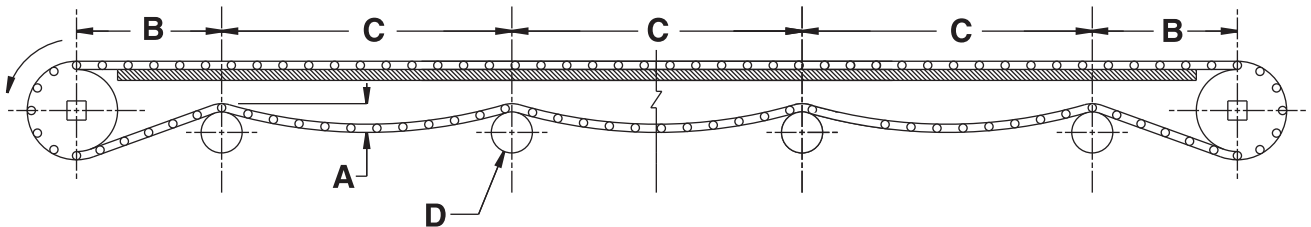

Fig. 3-12 Medium to long conveyors (6' [1.8 m] and longer)

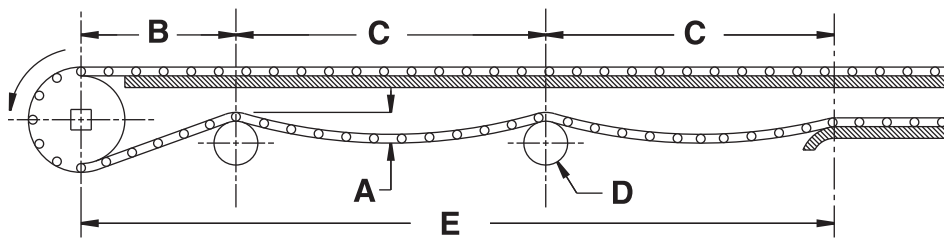

Fig. 3-13 Conveyors with slide beds

E -Slide beds should begin at least 60 in. (1524 mm) from the drive sprockets. A combination of return rollers and a slide bed can also be used. The catenary spans should total at least 1/3 of conveyor length.

Roller returnways

As the length of the conveyor increases, it is necessary to provide intermediate support rollers in the returnway, but it is most important the belt be unsupported for a significant part of the total length, as shown in the following figures.

Slide bed returnways

If a slide bed is used as part of the returnway, it should begin at least 60 in. (1524 mm) from the drive sprockets. See "Fig. 3-13 Conveyors with slide beds" for more details.

SPECIAL TAKE-UP ARRANGEMENTS

Catenary sag may be described as a dynamic take-up. In many applications it does not provide adequate tension to prevent sprockets from slipping. In these cases, other types of take-ups are required.

• Gravity style take-ups

Gravity style take-ups usually consist of a roller resting on the belt in the returnway. Its weight provides the tension needed to maintain proper sprocket engagement. The weight is most effective when placed near the drive shaft end of the returnway. These take-ups are recommended for *conventional* conveyors which are:

1. over 75 ft. (23 m) long, or
2. over 50 ft. (15 m) long with belt speeds over 150 ft/min (30 m/min), or
3. exposed to large temperature variations, or
4. operated at speeds over 50 ft/min (15 m/min), and with frequent starts under loads of over 25 lb/ft² (120 kg/m²).

For 1.00 in. (25.4 mm) pitch belts, a 4 in. (102 mm) diameter roller with a weight of 10 lb/ft (15 kg/m) of belt width is recommended. For 2.00 in. (50.8 mm) pitch belts, the recommended specifications are 6 in. (152 mm) diameter and 20 lb/ft (30 kg/m) of belt width.

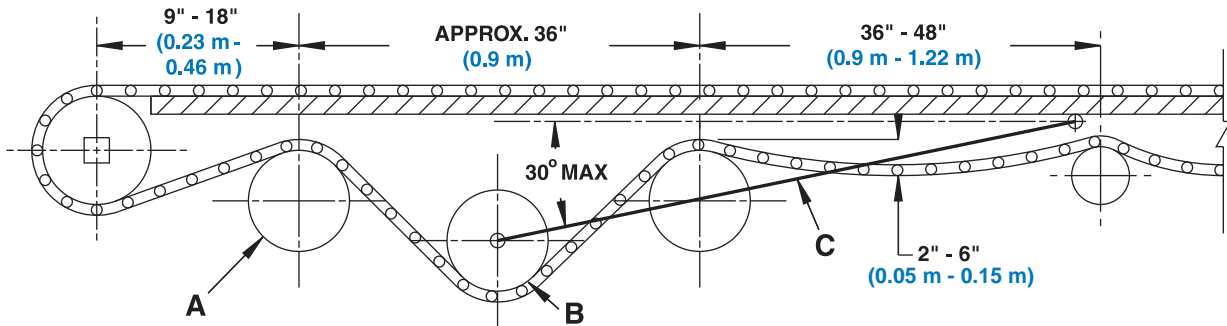

To Create Back Tension on Short Conveyors

- A -Load-bearing shafts (typical) B -Gravity take-up roller C -Swing arm

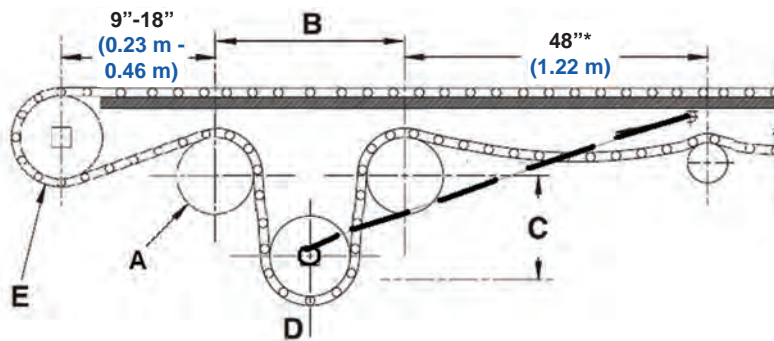

To Create Back Tension and Belt Storage on Long Conveyors

A -Load-bearing roller diameter should be at least 3 times the belt pitch.

Pitch	Load-Bearing Roller Diameter
For 0.5 in. (12.7 mm) pitch	2 in. (50.8 mm) dia.
For 0.6 in. (15.2 mm) to 1 in. (25.4 mm) pitch	4 in. (101.6 mm) dia.
For 2 in. (50.8 mm) pitch	6 in. (152.4 mm) dia

B -Spaced just far enough for the opening between rollers A to be bigger than roller D

C -This distance must be no less than 3 times the belt pitch

D -At least as big as A (swing arm optional, if necessary)

E -Drive sprocket

* Typical

Fig. 3-14 Gravity style take-up

• Screw style take-ups

Screw style take-ups shift the position of one of the shafts, usually the idler, through the use of adjustable machine screws. The shaft bearings are placed in horizontal slots in the conveyor frame. The screw style take-ups are used to move the shaft longitudinally, thus changing the length of the conveyor.

Screw take-ups should be used only to make minor adjustments to return the catenary sag to its best position. They should not be used as primary length control devices.

The disadvantages of screw take-ups are that shafts can be misaligned easily, and the belt can be over tightened, reducing belt and sprocket life as well as increasing shaft deflection.

SPECIAL CONVEYORS

BI-DIRECTIONAL CONVEYORS

Bi-directional conveyors are usually designed in two basic drive configurations: the **Pull-pull** type and the **Push-pull** type. There are some features common to both, but each has certain advantages and disadvantages. The illustrations and comments below describe the differences between the two types.

Pull-pull designs

There are three common variations of the Pull-pull type, notably the center-drive method, the two-motor drive method, and the single-motor and slave-drive method.

• Center-drive design

The center-drive is shown in “Fig. 3-15 Center-driven bi-directional conveyor” and “Fig. 3-16 Center drive with nose bars”. The reversible drive shaft is placed in the returnway near the center of the conveyor. This drive shaft should be placed to allow adequate belt tension to develop on both sides of the returnway with catenary sag sections. Notice that the rollers designated as “A” in the illustration are load-bearing. The shafts and bearings which support them should be so designed.

Center-drive bi-directional conveyors, when designed correctly, afford excellent operating characteristics because sprocket engagement occurs over 180° of rotation. In addition, only one reversing motor is required.

Note: Because belt tension is applied to both the carryway side and returnway side of the idler shafts at opposite ends of the conveyor, these shafts must be designed for twice the belt tension determined by calculations of the **ADJUSTED BELT PULL, (ABP)**. Therefore, the shaft deflection calculations and sprocket spacing determination should be based upon two times the Adjusted Belt Pull. Because of these larger shaft loads, it is sometimes necessary to use very large shafts, or to use rollers in lieu of idle sprockets and shafts on these designs.

• Two-motor drive design

The two-motor drive design has the advantage of relatively low returnway belt tension, but requires additional hardware (an additional motor and slip clutches) and electrical control components. Despite the additional equipment needed, on extremely large units with heavy loads, this is often the most practical drive system.

• Single-motor and slave-drive design

The single-motor (reversible) employing a roller chain, alternately driving either of two chain sprockets on the conveyor shafts, is another low-tension option. It is also expensive because of the additional hardware required. This drive system is usually limited to short conveyors because of the length of roller chain involved.

Push-pull designs

Push-pull bi-directional conveyors (“Fig. 3-17 Push-pull bi-directional conveyor”) require special attention to returnway tension, shaft deflection and sprocket spacing. When the driving shaft is *pulling* the load towards itself, the conveyor acts like other conventional units. *When the direction of belt travel is reversed*, the drive shaft is *pushing* the loaded belt. In this situation, *if the return side tension is not greater than the carryway tension, sprocket slipping or jumping will occur*. Excess belt may buckle upwards in the carryway interfering with product handling.

It is vital to design a Push-pull bi-directional conveyor with the required return side belt tension. Experience has shown this needs to be about 120 percent of the *carryway side ADJUSTED BELT PULL (ABP)*. See the Belt Selection Instructions page 20, or the Formulas page 446. Having determined the carryway side ABP, the returnway tension is:

Required Returnway Tension = $1.2 \times \text{ABP}$

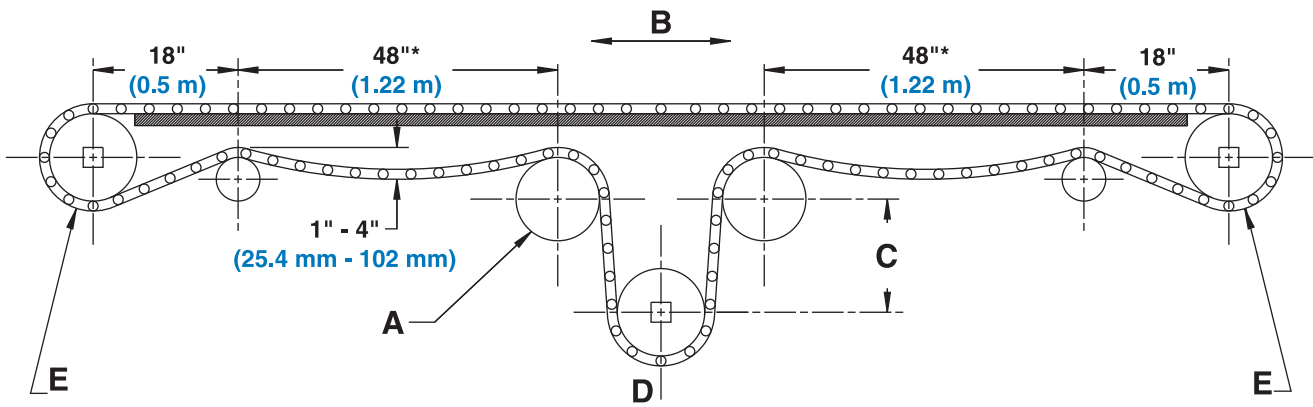

A -Load-bearing rollers (typical):

- For 0.5 in. (12.7 mm) pitch, 2 in. (50.8 mm) dia.
- For 0.6 in. (15.2 mm) to 1 in. (25.4 mm) pitch, 4 in. (101.6 mm) dia.
- For 2 in. (50.8 mm) pitch, 6 in. (152.4 mm) dia.
- For 2.5 in. (63.5 mm) pitch, 8 in. (203.2mm) dia.

B -Belt travel

C -This distance must be no less than 3 times the belt pitch

D -Drive sprockets

E -Rollers may be substituted for sprockets to avoid using intermediate bearings. On conveyors having a length of no greater than twice the width, unspooled rollers may be used. On longer conveyors, the rollers should be spooled allowing 3/16 in. (5 mm) to 3/8 in. (10 mm) clearance between the inside of the flange and the belt edges.

Note: For belts operating at temperatures above ambient, this clearance should exist at operating temperature.

* Typical

Fig. 3-15 Center-driven bi-directional conveyor

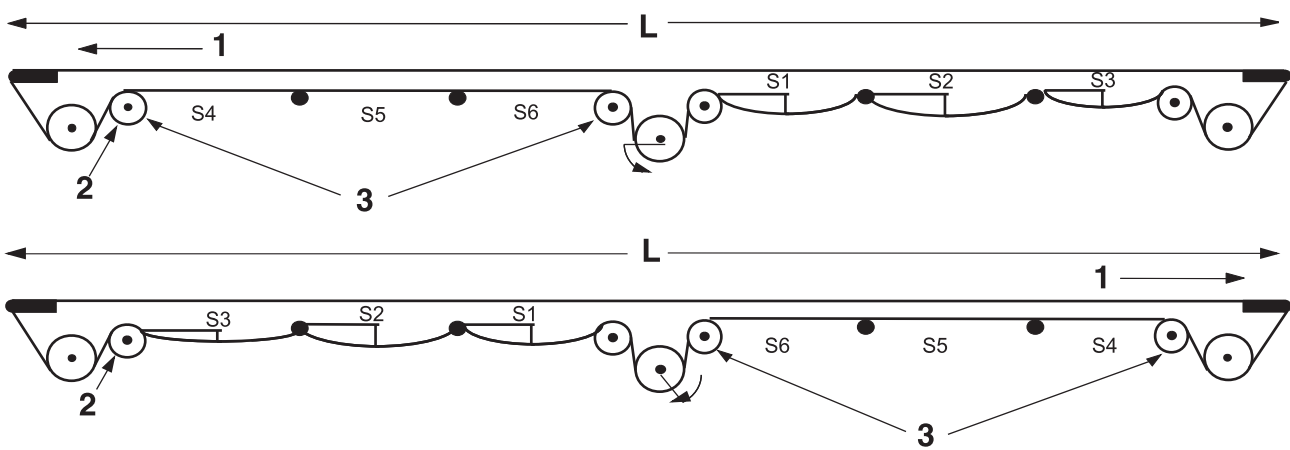

1 -Belt travel

2 -Snub rollers

3 -Reaction force

L -Length of conveyor, ft. (m), \varnothing to \varnothing

Fig. 3-16 Center drive with nose bars

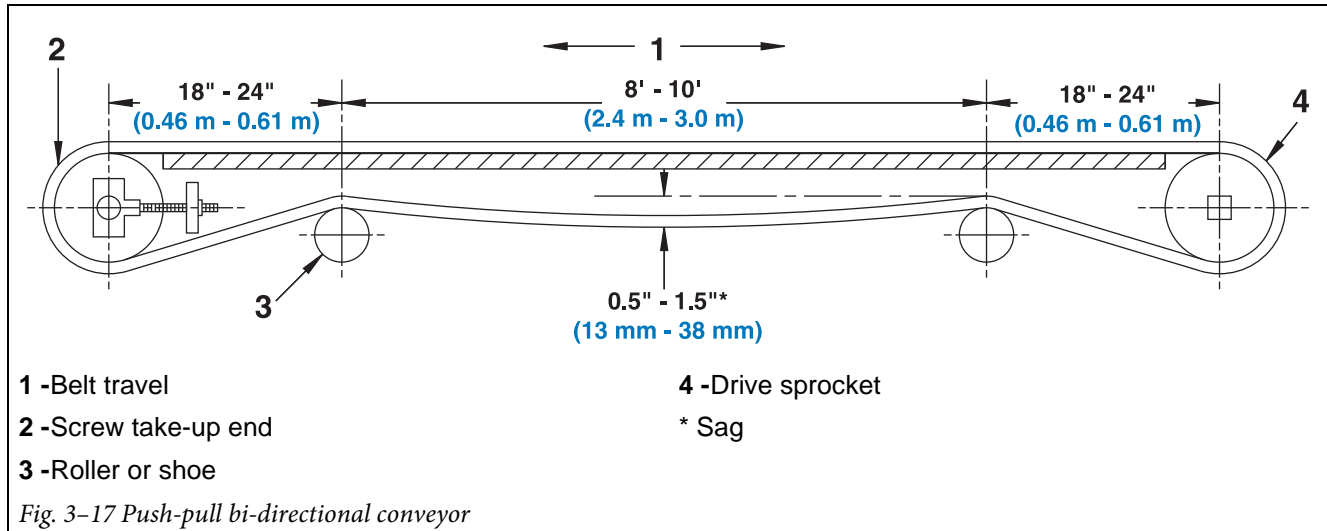

Fig. 3-17 Push-pull bi-directional conveyor

• Effect on shaft deflection and sprocket spacing

Since both drive and idler shafts will experience a tension load as the belt approaches and leaves the sprockets, the total shaft loading is more than twice that of a conventional uni-directional conveyor. Therefore, when calculating the shaft deflection, it is most important to increase the Total Running Shaft Load for the added belt tension. The corrected Adjusted Belt Pull can be found from:

$$\text{Corrected ABP} = 2.2 \times \text{ABP}$$

Use this value in calculating the Total Shaft Load and Shaft Deflection. Formulas for these may be found in the "Belt Selection Instructions" (page 20), or the "Formulas" (page 446). Because the belt is tensioned on both sides of the sprockets, a greater shaft deflection of about 0.22 in. (5.6 mm) is tolerable for these conveyors.

The **Corrected ABP** should also be used in determining the proper spacing of shaft sprockets. See the **Drive Shaft Sprocket Spacing** chart in "Section two: Product line" for the belt being considered. Remember that **both shafts** should be considered as drive shafts for deflection and sprocket spacing calculations.

The power and torque needed to drive the Push-pull unit is not affected by the returnway tension, however, the greater shaft loading does affect the loads on bearings. The designer is therefore cautioned to allow for this additional load in the selection of the shaft bearings.

ELEVATING CONVEYORS

Elevating conveyors are similar to horizontal units with several design differences required for good operation. First, *the upper shaft is strongly recommended as the drive shaft*. The extreme difficulty of "pushing" product up an incline precludes this as a viable alternative. Second, as the angle of incline increases, the effectiveness of catenary sag as a method of length control decreases. *It is always recommended that some mechanical form (screw or spring) of take-up be employed on the lower or idler shaft.*

Elevators almost always involve the use of flights and sideguards which present special requirements in the design. For example, shoes or slide beds on the return side must be designed so these flights or sideguards will not interfere with the smooth operation of the conveyor. The illustrations and comments in "Fig. 3-18 Incline conveyor" through "Fig. 3-22 Elevating conveyor with shoe return" show five different variations of elevating conveyors.

GENERAL NOTES ON ELEVATING CONVEYORS: THESE NOTES APPLY TO "Fig. 3-18 Incline conveyor" TO "Fig. 3-22 Elevating conveyor with shoe return".

- A** -If sprockets are used at intermediate points, the center sprockets are NOT retained. If rollers or shoes are used, a 3 in. (76 mm) minimum radius is required for 1.00 in. (25.4 mm) pitch belts; a 5 in. (127 mm) minimum radius for 2.00 in. (50.8 mm) pitch belts.
- B** -To minimize wear, the hold down shoe radius should be as large as the application will allow. The minimum radius should be 6 in. (152 mm).
- C** -Internal roller or shoe should have a minimum diameter of 3 in. (76 mm).
- D** -Consider a drum or scroll on the idle end if product or foreign materials are expected to fall between the belt and the sprockets.
- E** -Keep drip pans clear of flights and sideguards between drive sprockets and the first shoe or roller.
- F** -For proper sprocket engagement, do not allow belt sag to develop between the drive sprocket and the first roller or shoe.

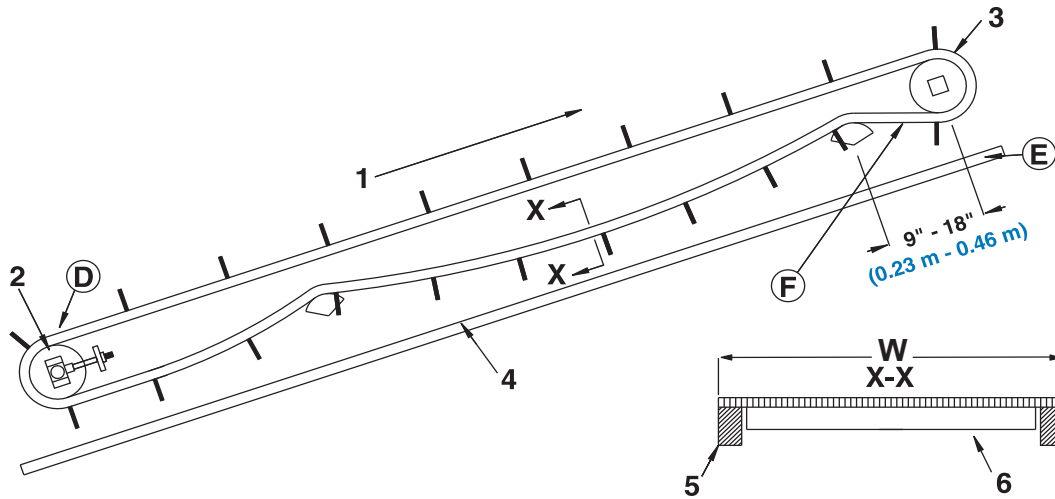

- 1 -Belt travel
- 2 -Idle sprocket
- 3 -Drive sprocket
- 4 -Guard or drip pan as required
- 5 -Shoe or rollers
- 6 -Flights

Note: Center notch required if "W" (Belt Width) exceeds 24 in. (610 mm) (for belt pitch > 1.07 in. [27.2 mm]) or 18 in. (457 mm) (for belt pitch ≤ 1.07 in. [27.2 mm]).

Fig. 3-18 Incline conveyor

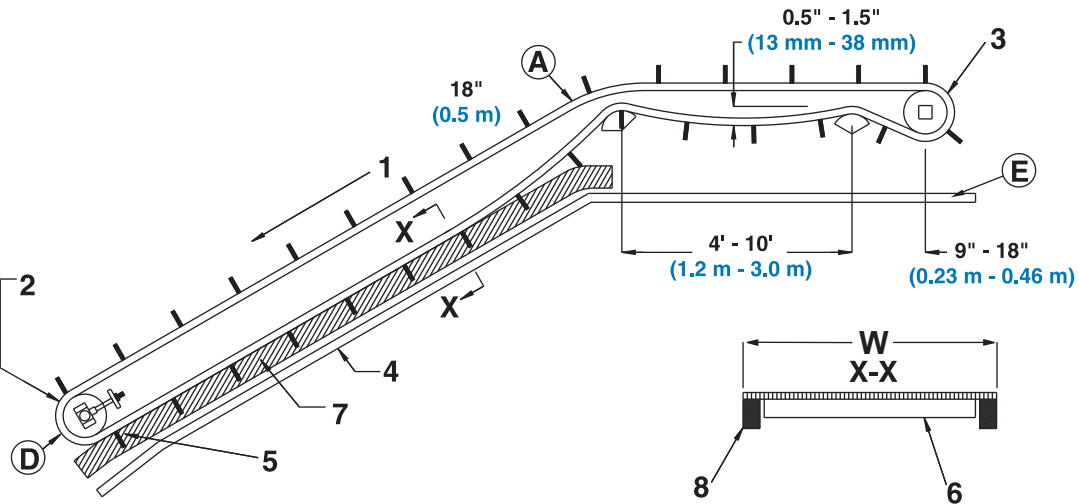

- 1 -Belt travel
- 2 -Idle sprocket
- 3 -Drive sprocket
- 4 -Guard or drip pan as required
- 5 -Active take-up should be used on idle end to maintain adequate return side tension
- 6 -Flights
- 7 -Slider supports
- 8 -Slider supports on belt edges

Note: Catenary length of 4' (1.2 m) to 5' (1.5 m) for loads under 10 lb/ft² (50 kg/m²).

Note: Catenary length of 8' (2.5 m) to 10' (3 m) for loads over 10 lb/ft² (50 kg/m²).

Note: Center notch required if "W" (Belt Width) exceeds 24" (610 mm).

Fig. 3-19 Decline conveyor

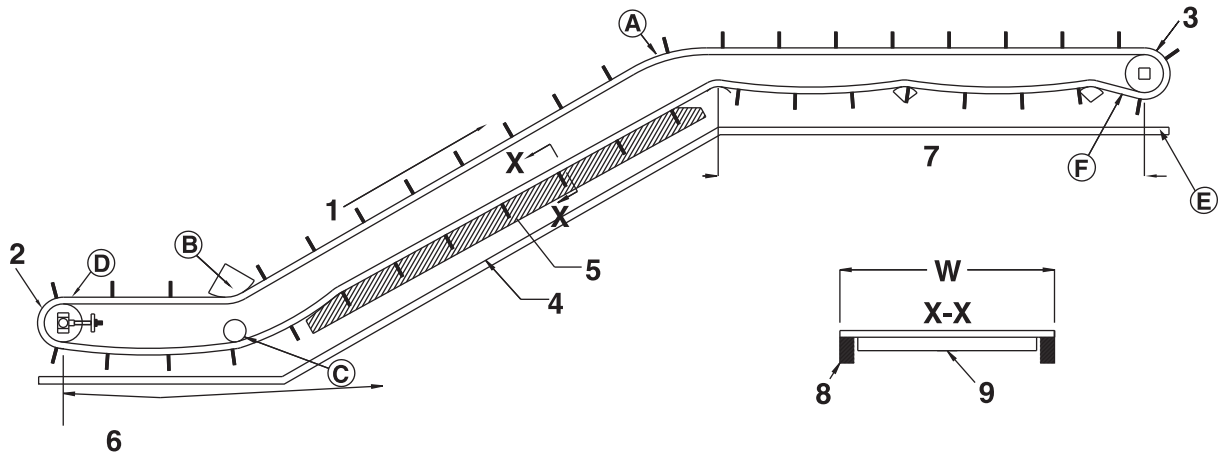

- 1 -Belt travel
- 2 -Idle sprocket
- 3 -Drive sprocket
- 4 -Guard or drip pan as required
- 5 -Slider supports
- 6 -Provide adequate unsupported length for sag to absorb expected belt elongation, or provide active idle end take-up — gravity, spring-loaded or pneumatic type
- 7 -Use returnway design dimensions on page 429
- 8 -Slider supports on belt edges
- 9 -Center notch required if “W” (Belt Width) exceeds 24 in. (610 mm) (for belt pitch > 1.07 in. [27.2 mm]) or 18 in. (457 mm) (for belt pitch ≤ 1.07 in. [27.2 mm]).

Fig. 3-20 Elevating conveyor with belt edge slider return

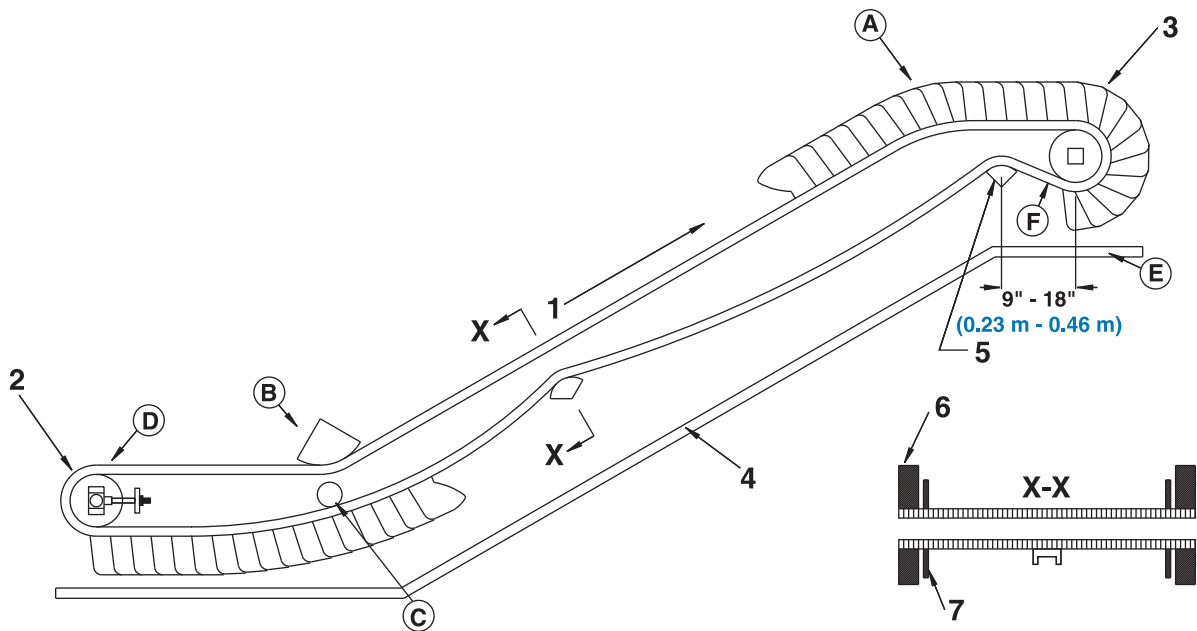

- 1 -Belt travel
- 2 -Idle sprocket
- 3 -Drive sprocket
- 4 -Guard or drip pan as required
- 5 -Minimum backbend radius 4.5" (115 mm)
- 6 -Shoes or rollers
- 7 -Sideguards

Fig. 3-21 Elevating conveyor with wide sideguards and shoe return

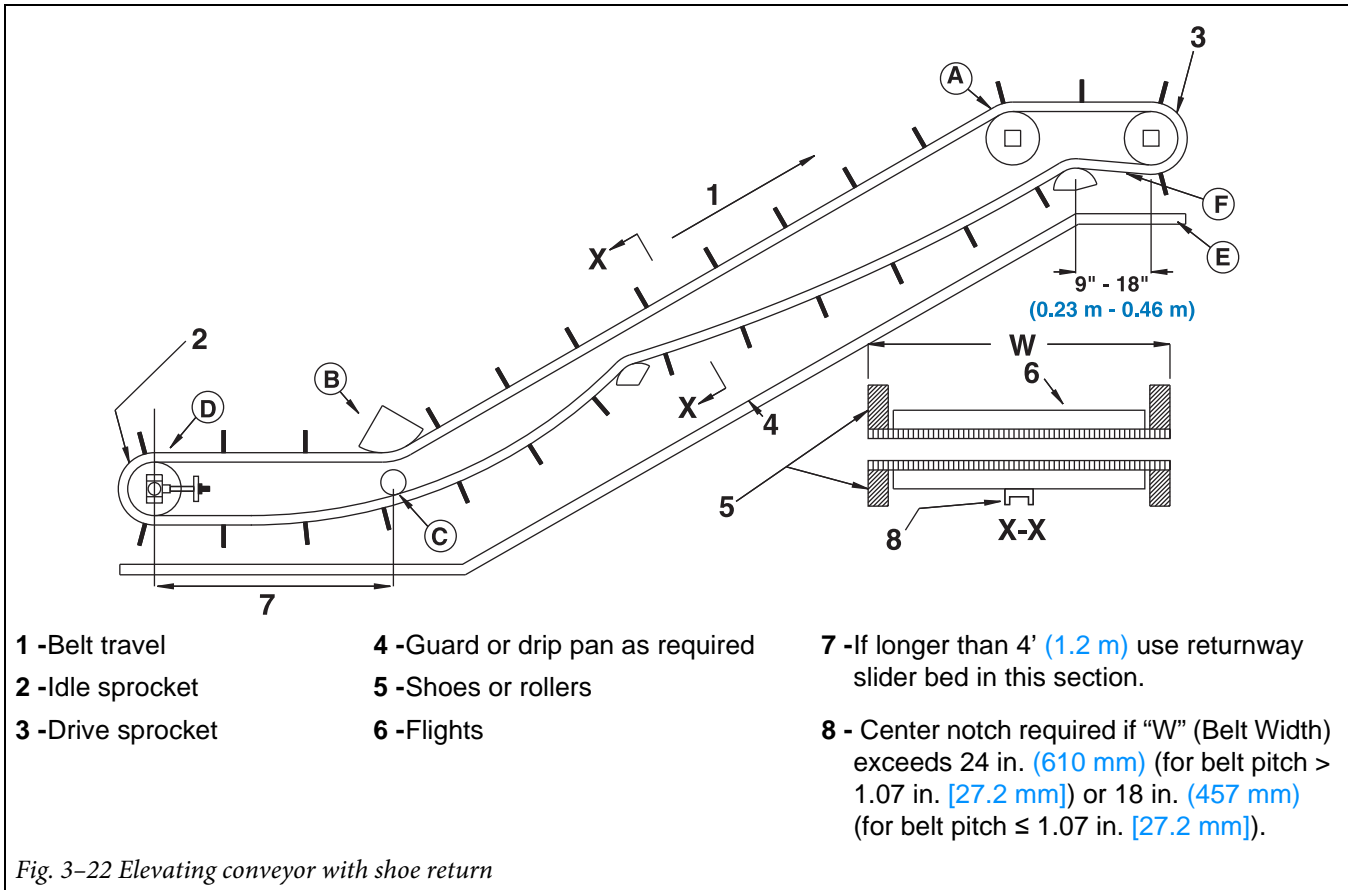

Fig. 3-22 Elevating conveyor with shoe return

Hold down rollers

Some elevating conveyors can employ Hold Down Roller assemblies in place of hold down shoes or rollers. These roller assemblies ride in steel rails on the carryway and returnway side of the conveyor. To minimize wear, the rail bend radius should be as large as the application allows. The minimum bend radius should be 12 in. (305 mm). The minimum rail thickness should be 0.125 in. (3.2 mm), and should be at least 0.75 in. (19 mm) wide. The minimum bend radius is proportional to the thickness of the carryway rail. A thicker rail will require a larger bend radius. Normally, the roller assemblies are spaced every fourth row along the length of the belt. The tightest spacing possible is every second row. Assembly spacing has no effect on bend radius.

When large temperature variations will be encountered, rails must be placed carefully to accommodate the thermal expansion of the belt. The transverse movement of the roller assemblies can be calculated by using the **Coefficients of Thermal Expansion** (page 443). The distance of the hold down roller assembly to the belt centerline is used to calculate the movement.

For example:

A 24 in. (610 mm) **Series 400 Flush Grid** polypropylene belt, with hold down rollers indented 4 in. (102 mm) from each side, will operate at 100 °F (38 °C). The distance at ambient temperature, 70 °F (21 °C), from a hold down roller assembly to the belt centerline is 8 in. (203 mm).

$$\Delta = L_1 \times (T_2 - T_1) \times e$$

$$\Delta = 8 \text{ in.} \times (100 \text{ °F} - 70 \text{ °F}) \times 0.0008 \text{ in./ft./°F} \times \frac{1 \text{ ft.}}{12 \text{ in.}}$$

$$\Delta = 0.016 \text{ in. (0.41 mm)}$$

where

- L_1 = distance from hold down roller to belt centerline
- T_1 = ambient temperature
- T_2 = operating temperature
- e = thermal expansion coefficient (0.0008 in/ft/°F for polypropylene)

Each hold down roller assembly will move 0.016 in. (0.41 mm) when the belt is raised to operating temperature.

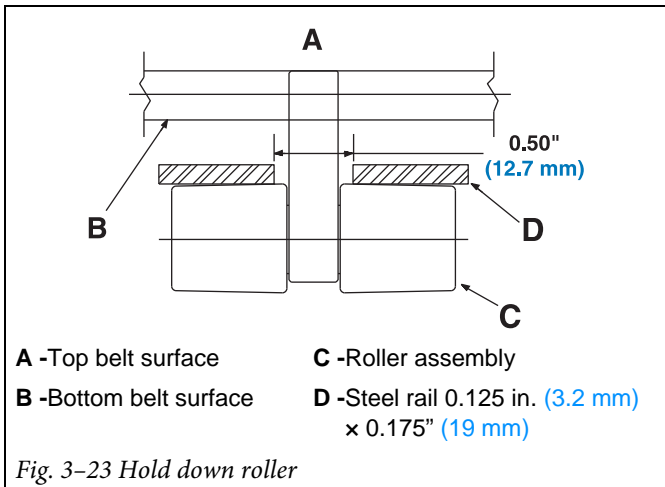

Fig. 3-23 Hold down roller

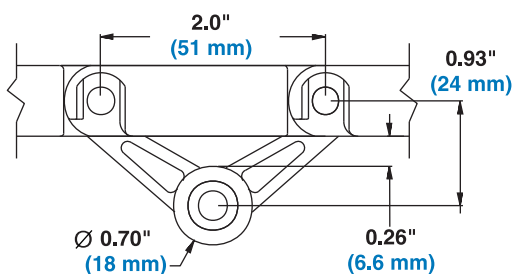
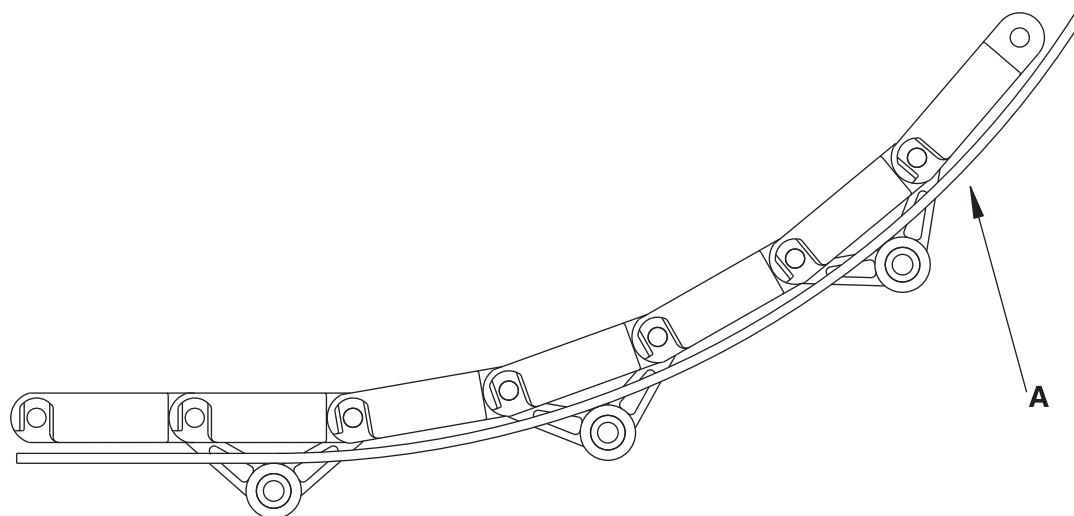

Fig. 3-24 Hold down roller, side view



A -Bend radius 12 in. (305 mm) with 0.125 in. (3.2 mm) thick rail

Hold down rollers installed in **Series 400 Flush Grid** every 4 in. (102 mm)

Fig. 3-25 Hold down roller, side view

Buckets for Series 200 belts

Buckets are available for use with **Series 200 Open Grid, Flush Grid, Flat Top** and **Perforated Flat Top** belts. The same guidelines that apply to flighted belts generally apply to belts with buckets. The minimum backbend radius of a belt with buckets is 3.5 in. (88.9 mm). Rollers and shoes must be sized accordingly.

Sprockets cannot be located behind the bucket gussets. Gussets will interfere with the normal action of the sprockets.

Friction modules

Several Intralox belt styles incorporate a high friction material to move products (cartons, trays, bags, etc.) on inclines.

• Integral friction surface modules

The high friction rubber of Friction Top modules is molded to a polypropylene or polyethylene base. Normal wearstrip, carryway and sprocket recommendations apply.

Conveyor design issues for friction modules

The following guidelines apply:

- The returnway must be designed to eliminate rubbing contact with friction modules. When using return rollers, the minimum roller diameter should be 3 in. (76 mm). Refer

to “Elevating conveyors” (page 434) for detailed returnway information.

- The friction between the product and the belt is deliberately very high. Flow pressures and belt pulls will be high in applications where the product is allowed to back up. These situations are not recommended for any friction top belt.
- End-to-end transfers at both the in-feed and discharge ends are recommended. Sliding side transfers are ineffective due to the high friction quality of the friction modules.
- Thermal expansion is controlled by the base material.
- Operating temperature limits are controlled by the limits of both the friction top material and the base material.

RADIUS CONVEYORS

Series 2200 and **Series 2400** are designed for radius applications that have a turning radius of 2.2, measured from the inside edge of the belt (1.7 for Tight Turning Series 2400). Radius systems have many more design considerations than straight running systems. Some of these are discussed in “Section two: Product line”. The data pages for **Series 2200** and **Series 2400** list requirements for both calculating the belt loads on a radius system and basic design requirements for each belt. Contact Technical Support Group for more detailed information.

TIGHT TRANSFER METHODS

Series 1100 has two small steel sprockets for very tight end-to-end transfers. The 1.6 in (40 mm) and 2.3 in (59 mm) pitch diameter sprockets both offer positive drive and tracking of the belt, and allow use of very small transfer plates. When even tighter transfers are desired, nosebars or rollers may be used. The smallest nosebar diameter recommended for **Series 1100** is 0.875 in (22.2 mm). Dead plates can be as small as 1 in (25.4 mm) wide.

Arrangements which allow the nosebars to rotate freely are preferred. Belt tension increases dramatically as it slides around stationary nosebars. The increased belt pull is a function of the friction between the sliding belt and the stationary nosebar, and the angle of wrap between the belt and the nosebar.

Nosebar conveyors often cause an increased amount of belt hinge movement, leading to accelerated hinge wear. Therefore, we recommend to use premium materials for both modules and rods. If the application allows this, acetal modules and AR-nylon rods are the preferred materials. Contact Customer Service for recommendations specific to your application.

The nosebar material should be selected to result in the lowest possible sliding friction between the belt and nosebar. Lower friction will reduce belt tension. The amount of belt wrap around the nosebar also affects belt tension. There should be as little wrap as possible. A common nosebar configuration is shown in “Fig. 3-26 Series 1100 nosebar configuration — End drive”. For belts with a pitch less than 0.6 in (15.2 mm), refer to Series 550 Nosebar Conveyor Design Guidelines.

A static nosebar is often exposed to a combination of high contact pressure and high belt speed. Therefore, the nosebar

material should be able to deal with this combination of pressure (P) and speed (v). For the combination of relative low speed and low pressure, a wear-resistant material like oil-filled nylon works well (check PV-value with your supplier). For applications with high contact pressure and/or high belt speed, a noseroller is recommended (check applied forces and rpm with your supplier).

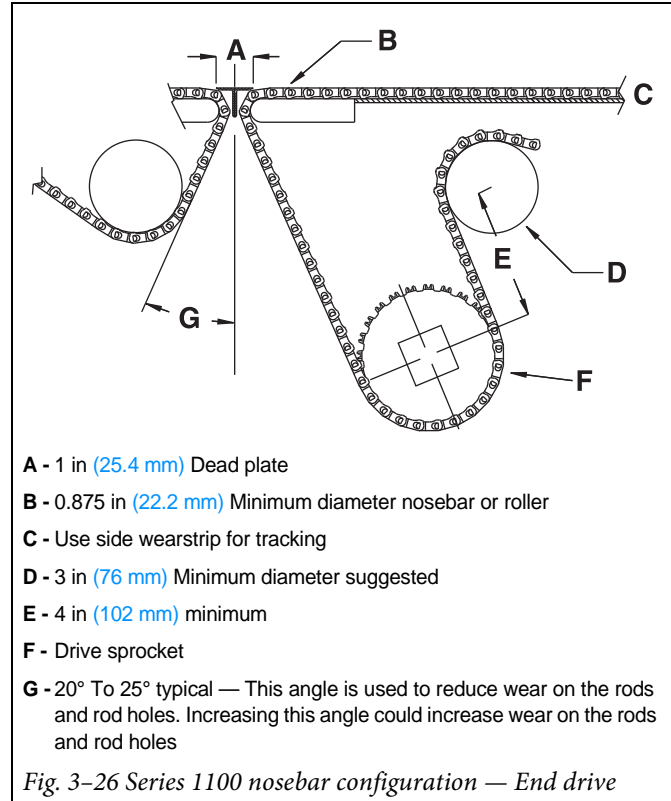

TRANSFER DESIGN GUIDELINES

END-OFF/END-ON TRANSFERS

Finger Transfer Plates

Intralox Raised Rib belts and matching finger transfer plates are a highly efficient, low maintenance transfer system currently used in many container handling applications.

Correct installation of finger transfer plates is essential for trouble free service and long belt life. Proper installation is particularly important in areas where belting is subjected to high temperature variations and significant thermal expansion.

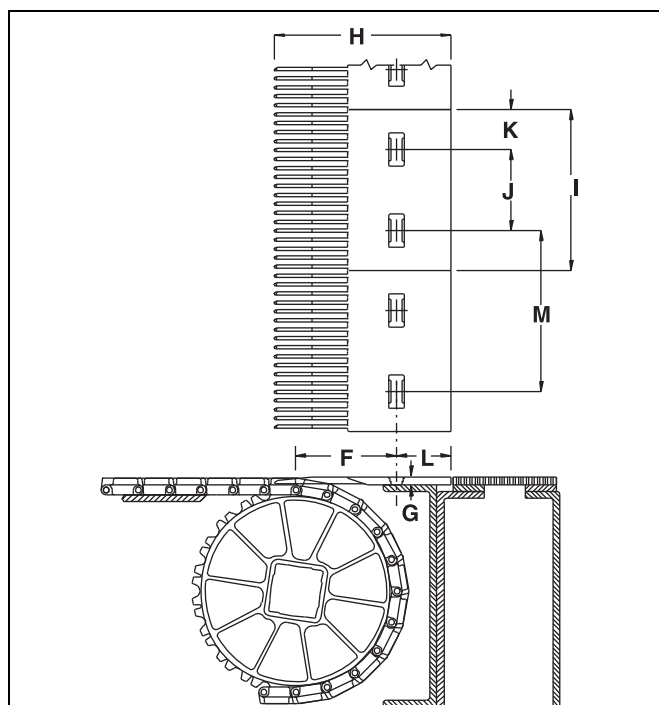

For an even number of finger transfer plates, locate from the centerline of the belt. Straddle the centerline for an odd number of plates

The finger transfer plate is to be level with the belt +0.03 in. (0.8 mm), -0.00 with hinge rod at top dead center.

Fig. 3-27 Finger transfer plates dimensional requirements

DIMENSIONAL REQUIREMENTS FOR FINGER TRANSFER PLATE INSTALLATION in. (mm)

	SERIES 100, 2400		SERIES 400 ^a		SERIES 1200 ^b		SERIES 900		SERIES 1900			
							6 in. (152 mm)	4 in. (102 mm) retrofit				
F	2.38	(61)	3.50	(89)	3.50	(89)	3.50	(89)	2.38	(61)	3.50	(89)
G	0.19	(5)	0.31	(8)	0.31	(8)	0.25	(6)	0.19	(5)	0.31	(8)
H	5.83	(148)	7.25	(184)	7.25	(184)	6.50	(165)	5.83	(148)	6.11	(155)
I	3.96	(101)	5.91	(150)	5.91	(150)	5.92	(150)	3.94	(100)	5.91	(150)
J	2.50	(64)	3.00	(76)	3.00	(76)	3.00	(76)	2.18	(55)	3.00	(76)
K	0.74	(19)	1.45	(37)	1.45	(37)	1.45	(37)	0.90	(23)	1.45	(37)
L	2.00	(51)	2.00	(51)	2.00	(51)	2.00	(51)	2.00	(51)	5.50	(140)
M	Spacing											
Spacing at Ambient Temp.	Polypropylene	Acetal	Polypropylene	Polyethylene	Polypropylene Composite	Polypropylene	Acetal	Acetal	Enduralox™ Polypropylene			
	3.979 (101.1)	3.976 (101.0)	5.952 (151.2)	5.933 (150.7)	6.000 (152.4)	5.981 (151.9)	5.975 (151.8)	3.976 (101.0)	6.000 (152.4)			

a. Dimensions are for two-material, **Series 400** Standard Finger Transfer Plates only. See page 56 **Series 400** Finger Transfer Plate dimensions for more information.

b. Dimensions are for two-material, **Series 1200** Standard Finger Transfer Plates only. See page 183 **Series 1200** Finger Transfer Plate dimensions for more information.

The metal plate support angle used to secure the finger transfer plates to the conveyor frame should be drilled and tapped for 1/4 – 20 screws (metric size M6). *Accurate drilling and tapping are important!* Finger transfer plates are molded with slots for Intralox shoulder bolts. These bolts prevent the plate from being clamped too tightly to the support angle. The loose fit allows the plates to move laterally and remain

properly engaged with the belt's ribs during expansion or contraction caused by changes in temperature. The length of the slots in the finger transfer plates limits the amount of expansion and contraction that can be accommodated. It is possible that very wide belts undergoing large temperature variations will exceed the expansion or contraction limits.

Contact Intralox Sales Engineering if the values shown in the accompanying table are not large enough for your application.

MAXIMUM BELT WIDTH × TEMPERATURE inches × °F (mm × °C)			
BELT MATERIAL	SERIES 100	SERIES 400	SERIES 900
Polypropylene	3750 (52,900)	15,000 (211,700)	7500 (105,800)
Polyethylene	2000 (28,200)	8000 (112,900)	4000 (56,400)
Acetal	5000 (70,600)	—	10,000 (141,000)

TEMPERATURE EFFECTS:

As temperature varies, the width of the belt changes in proportion to the magnitude of the temperature change. To ensure proper finger transfer plate operation, perform the following check:

1. Determine the maximum expected change in temperature from ambient, in °F (°C).
2. Multiply the maximum temperature change by the belt width, in inches (millimeters).
3. If the calculated value is greater than the value obtained from the chart, contact Intralox Sales Engineering before proceeding.

Dead Plates

Where there is a transfer point from a belt without finger transfer plates to a dead plate, there should be a gap between the surfaces to allow for the chordal action of the belt. As the belt engages its sprockets, chordal action causes the modules to move past a *fixed* point (the tip of the dead plate) with *varying* clearances. The Dead Plate Gap tables at the end of each Series in “Section two: Product line” show the minimum amount of gap which occurs at the “low point” of the modules if the tip of the dead plate just comes in contact with the “high point” as the modules pass.

In some installations it may be desirable to keep the tip of the dead plate in contact with the belt, rather than allow a gap to occur. This can be done by hinging the mounting bracket for the dead plate. This allows the dead plate to move as the modules pass, but results in a small oscillating motion which may present tipping problems for sensitive containers or products.

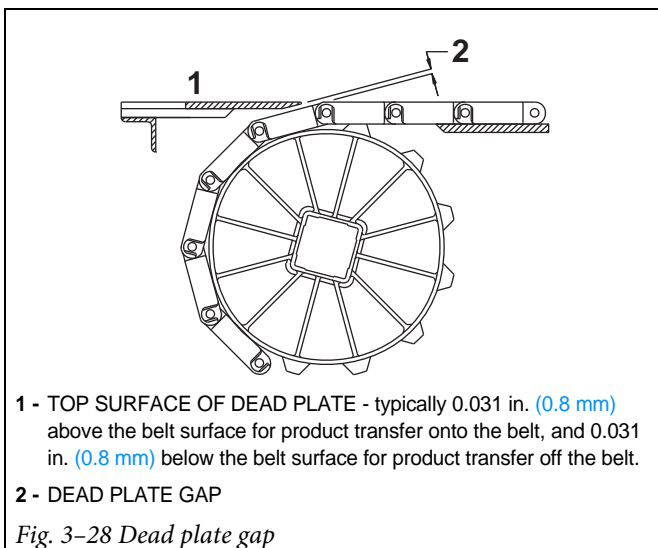

90° Container Transfers

When transferring containers on beverage lines from one conveyor to another at a 90° angle, it is common practice to use full radius guide rails with dead plates which span the space between the delivery and the takeaway conveyors. Containers moving along the full radius guide rail exert high pressure on the rail (“Fig. 3-29 Conventional full radius guide rail contours”), and on each other, often resulting in container damage. Pressure forces peak to the end of the outer curve as the containers move onto the dead plate.

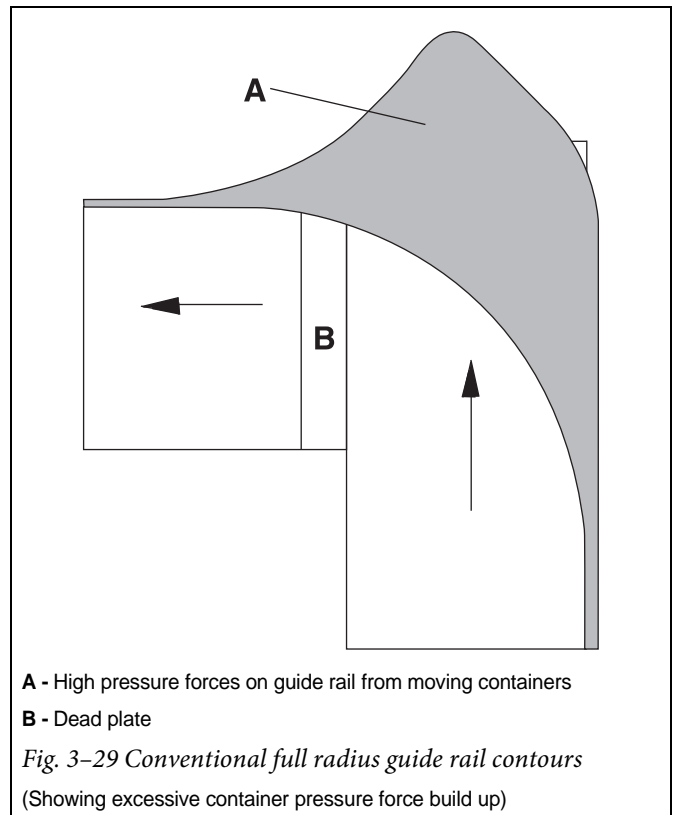

Parabolic guide rails

The **parabolic guide rail** was designed by a beverage industry engineer for better distribution of the container pressure forces along the outer guide rail. In “Fig. 3-30 Parabolic guide rail contours” is shown that the forces are more evenly distributed. This results in significantly less potential for container damage along the outer rail. However, an excessively large dead area, which strands containers, arises along the *inner* parabolic guide rail contour.

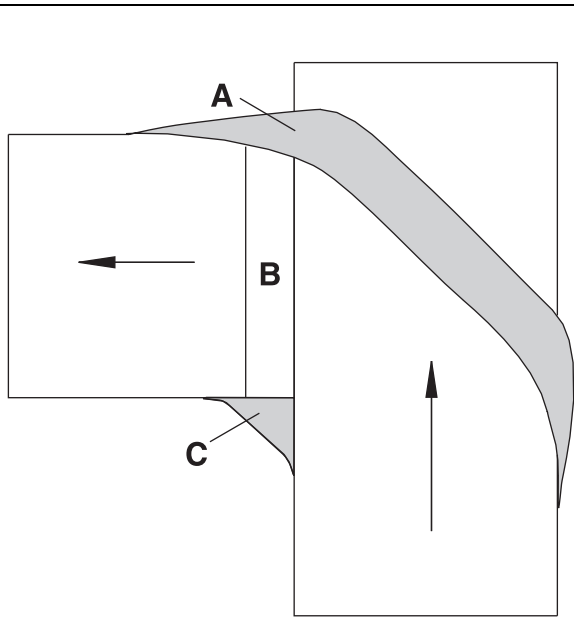

- A - More evenly distributed pressure forces from moving containers
- B - Dead plate
- C - Dead area

Fig. 3-30 Parabolic guide rail contours

(Showing reduced pressure force build up and dead area)

Series 900, Series 1100 and Series 1400 **ONEPIECE™** Live Transfer belt

A solution to the dead area problem incorporates a **Series 900, Series 1100** or **Series 1400 ONEPIECE™ Live Transfer Belt**, either slaved to the delivery conveyor or independently driven. In "Fig. 3-31 PARABOLIC GUIDE RAIL CONTOURS WITH 6.0 in. (152 mm) **ONEPIECE™ LIVE TRANSFER BELT**" a 6.0 in. (152 mm) transfer belt is shown running parallel to, and in the same direction as, the delivery conveyor. This eliminates the dead area along the inner parabolic guide rail, as well as the dead plate itself, enabling continuous container movement and eliminating stranded containers through the turn.

See "Section two: Product line" for more information on the **Series 900, Series 1100** and **Series 1400 ONEPIECE™ Live Transfer Belts**.

Contact Customer Service Sales Engineering for maximum number of sprockets allowed on Live Transfer Belts.

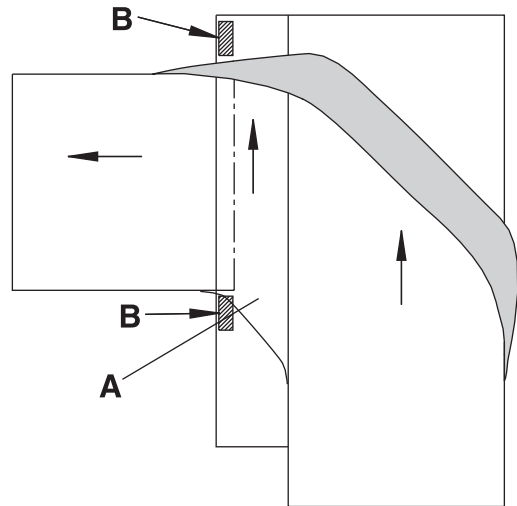

- A - 6.0 in. (152 mm) **ONEPIECE™** live transfer belt
- B - Support

Fig. 3-31 PARABOLIC GUIDE RAIL CONTOURS WITH 6.0 in. (152 mm) **ONEPIECE™ LIVE TRANSFER BELT**

Vacuum Transfer Applications

Series 900 and **Series 1100 Perforated Flat Top** belts are often used to invert empty containers which are held against the belt by a vacuum created on the opposite side of the conveyor. As the containers are carried around large diameter drums to the returnway side of the conveyor, they are inverted, then discharged from the belt.

The differential pressure acting to hold the containers to the belt also acts to hold the belt to the carryway. Thus, an *additional belt pull* is introduced. On small belts with low differential pressures, this added pull may be low and insignificant. On large belts with high differential pressures, the additional pull may be quite high. Under average conditions, the **SPECIFIC ADDED BELT PULL** should not exceed 1.25 lb/ft² (0.24 kg/m²) per inch (mm) water column, vacuum.

The designer may also be interested in the amount of air flow through the belt at various differential pressures. Air flow depends on the amount of open area, the differential pressure, the container spacing on the belt, and the air leakage around the perimeter of the belt. For air flow information on different belt series and styles, refer to "Table 11 AIR FLOW RATE THROUGH BELT, PER SQUARE FOOT OF BELT AREA" (page 458).

SPECIAL DESIGN GUIDELINES

THERMAL EXPANSION AND CONTRACTION

With few exceptions, the dimensions of all substances increase as their temperature is increased and contract as their temperature is decreased. Since plastics expand and contract rather significantly, this must be considered in the conveyor design whenever operating temperatures differ from ambient temperature.

The designer must allow for changes in both belt length and width to accommodate expansion or contraction. An adequate unsupported span in the returnway must be provided to absorb the increase in belt length. There must be sufficient side clearance, particularly on wide belts, to prevent interference with the side structure. In low temperature applications, the frame must support the belt fully in its cold condition, yet not interfere at ambient temperatures.

Changes in the dimensions of a belt are determined in this manner:

$$\Delta = L1 \times (T2 - T1) \times e$$

- where: Δ = change in dimension, in. (mm)
L, W = total belt length/width at initial temperature, ft. (m)
T2 = operating temperature, °F (°C)
T1 = initial temperature, °F (°C)
e = Coefficient of Thermal Expansion, in/ft/°F (mm/m/°C)

Example:

The ambient temperature is 70 °F (21 °C). The operating temperature is 180 °F (82 °C). What is the greatest increase in belt length and width of a 60 ft. (18.3 m) long by 10 ft. (3 m) wide polypropylene belt while in operation?

$$\begin{aligned} L &= 60 \times (180 - 70) \times 0.0010 \\ \Delta &= 6.6 \text{ in. (168 mm)} \end{aligned}$$

This belt will increase in length by 6.6 in. (134 mm), *not an insignificant amount*. Its width will expand by:

$$\begin{aligned} W &= 10 \times (180 - 70) \times 0.0010 \\ \Delta &= 1.1 \text{ in. (28 mm)} \end{aligned}$$

Therefore, this belt would need a method by which approximately 5.5 in. (140 mm) of increased belt length could be absorbed on the return side of the conveyor. The width of the conveyor frame would need to be approximately 1 in. (25 mm) wider than its corresponding design under ambient conditions.

COEFFICIENTS OF THERMAL EXPANSION		
MATERIALS	in/ft/°F	(mm/m °C)
BELTS		
ACETAL, HSEC ACETAL	0.00072	(0.11)
POLYETHYLENE		
Series 100 Belts	0.0015	(0.23)
Series 400 Raised Rib Belts	0.0015	(0.23)
All Other Belts	0.0011	(0.17)
POLYPROPYLENE		
(less than 100 °F [38 °C])	0.0008	(0.12)
POLYPROPYLENE		
(greater than 100 °F [38 °C])	0.0010	(0.15)
COMPOSITE POLYPROPYLENE	0.0004	(0.06)
NYLON (HR, HHR, AR)	0.0005	(0.07)
FLAME RETARDANT	0.0008	(0.12)
HI-IMPACT	0.0010	(0.156)
SELM	0.0005	(0.07)
WEARSTRIPS		
HDPE and UHMW PE		
-100 °F to 86 °F (-73 °C to 30 °C)	0.0009	(0.14)
86 °F to 210 °F (30 °C to 99 °C)	0.0012	(0.18)
NYLATRON	0.0004	(0.06)
TEFLON	0.0008	(0.12)
METALS		
ALUMINUM	0.00014	(0.02)
STEEL (Carbon and Stainless)	0.00007	(0.01)

EXPANSION DUE TO WATER ABSORPTION

If nylon belts are used in continuously wet, elevated temperature environments, they have a tendency to absorb water and expand both in length and width. If an application requires a nylon belt in these conditions, contact Intralox Sales Engineering to determine the approximate expansion due to water absorption of the belt.

“SLIP-STICK” EFFECT

Surging on long conveyors can be caused by a condition known as “slip-stick”. In this situation, the belt acts like a large spring or rubber band. The belt will make relatively short, pulsed movements throughout the length of the conveyor. The idle end of the belt may not move until there is enough belt tension to overcome the friction forces between the belt and the carryway. Instead of accelerating smoothly, the belt surges ahead. This in turn causes a brief drop in belt tension, allowing the belt to be slowed by friction. In some instances, the belt will even stop for a moment until the tension develops again. Then the process repeats itself. The idle end of the conveyor surges despite the constant speed of rotation of the sprockets at the drive end.

Carryway friction, belt stiffness, belt weight and length play a large role in determining the severity of surging in a conveyor. Stiffness is a reflection of how far a belt will stretch under a given tension. A stiffer belt will develop belt tension with less elongation. A lighter weight belt will not have as much friction force to overcome.

Other factors that can affect surging are chordal action, belt speed, drive system pulsation, return roller diameter and return roller spacing. Chordal action and drive system

pulsation can initiate surging. However, return roller diameter and spacing are more critical. Return rollers influence the way in which the belt in the returnway oscillates. Oscillation in the returnway can be transmitted to the carryway side of the belt, causing surging. For more information on roller spacing and diameter, see “Returnways and take-ups” (page 428). Chordal action information is presented on page 6.

SECTION FOUR: FORMULAS AND TABLES

Section Four provides the appropriate formulas and tables needed to calculate the values for selecting the proper belt for any application. This section also provides measurement conversion factors for all the units used in the formulas and

tables. A “*Chemical Resistance Guide*” (page 461) is provided to determine if the desired belt material will be chemically compatible for the application.

SYMBOLS USED

		UNITS OF MEASURE	
		ENGLISH (USA)	METRIC (SI)
BS	Belt Strength Rated [70 °F (21 °C)]	lb/ft of width	kg/m of width
ABS	Allowable Belt Strength at Operating Conditions	lb/ft of width	kg/m of width
ABSU	Allowable Belt Strength Utilized	%	%
BP	Belt Pull at Drive Sprocket	lb/ft of width	kg/m of width
ABP	Adjusted Belt Pull	lb/ft of width	kg/m of width
M	Product Loading on Belt	lb/ft ²	kg/m ²
M _p	Backed-up Product Load	lb/ft ²	kg/m ²
W	Weight of Belt	lb/ft ²	kg/m ²
℄	Centerline	—	—
L	Length of Conveyor, Shaft ℄ to Shaft ℄	ft.	m
H	Elevation Change of Conveyor	ft.	m
F	Total Friction Factor	—	—
F _w	Friction Coefficient, Wearstrip to Belt	—	—
F _p	Friction Coefficient, Product to Belt	—	—
SF	Service Factor	—	—
B	Width of Belt	ft.	m
Q	Weight of Shaft	lb/ft	kg/m
w	Total Load on Shaft	lb	kg
L _s	Length of Shaft, between Bearings	in.	mm
T _o	Torque on Drive Shaft	in-lb	kg-mm
PD	Pitch Diameter of Sprockets	in.	mm
V	Speed of Belt Travel	ft/min	m/min
°F	Degrees, Fahrenheit	°F	—
°C	Degrees, Celsius	—	°C
T	Temperature Factor	—	—
S	Strength Factor	—	—
HP	Horsepower	hp	—
P _w	Power, Watts	—	Watts
E	Modulus of Elasticity (Young’s Modulus)	lb/in ²	kg/mm ²
I	Moment of Inertia	in. ⁴	mm ⁴
D	Deflection of Shaft	in.	mm
n	Shaft Speed of Rotation	rpm	rpm
∅	Diameter	in.	mm

FORMULAS

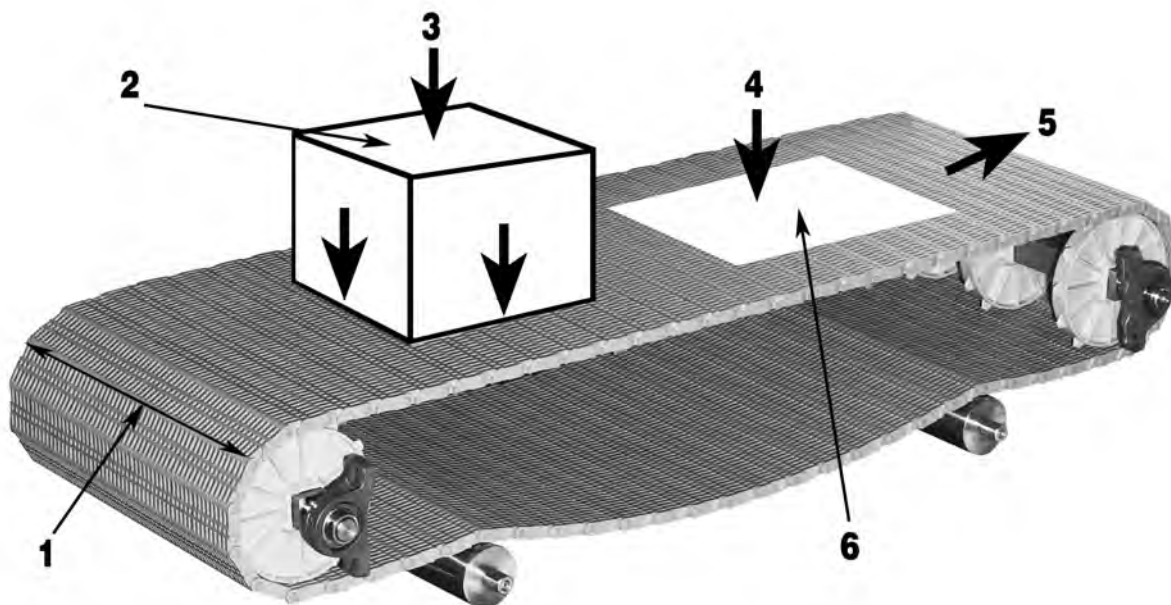

1 -B, beltwidth

2 -Unit area, 1 ft² (1 m²)

3 -M, product loading

4 -W, belt weight

5 -BP, belt pull per 1 ft (1 m) of width

6 -Unit area, 1 ft² (1 m²)

Fig. 4-1 Primary loads — conventional conveyor

CALCULATING BELT PULL OR TENSION LOAD

The tensile strength on an operating conveyor belt is produced by the combination of loads imposed by frictional resistance and by moving the product to a different elevation, should that be involved.

Frictional forces are developed in two ways. First, the weights of the belt *and* the product being conveyed bearing on the carryway create a resistance as the belt is driven. Second, if the product is held stationary while the belt continues to move under it, there is an added resistance between the belt and the product.

Each of these frictional forces is proportional to a **COEFFICIENT OF FRICTION**, which is dependent upon the materials in question, their surface qualities, the presence (or absence) of a lubricant, the cleanliness of the surfaces and other factors. Typical values of Coefficients of Friction for common conveying applications using Intralox belts are shown in **Tables 2-A** and **2-B** (page 454). The Coefficient of Friction between the belt and the carryway wearstrips is designated as F_w . The coefficient between the product being moved and the belt is represented as F_p .

The first step in calculating **BELT PULL, BP**, is calculation of the **BACKED-UP PRODUCT LOAD, M_p** :

FORMULA 1	(BACKED-UP PRODUCT LOAD)
$M_p = M \times F_p \times \left(\frac{\text{Percentage of Belt Area Backed-Up}}{100} \right)$	
<p>Note: If there is no slippage of product on the belt, nor “backed-up” product, ignore M_p, since it does not apply.</p>	

Notice that in **Table 2-A** there are dual listings of F_w for belts made of polypropylene, one for clean, smooth running applications and another for “abrasive” applications.

In this case, “abrasives” are defined as small amounts or low levels of fine grit, dirt, fiber or glass particles present on the carryway. The designer should be aware that many factors affect friction. Slight variations in conditions can produce wide deviations. Accordingly, when using friction coefficients in design calculations, allow for these variations.

After calculating M_p and finding the friction factor F_w , calculate the **BELT PULL, BP**, using this formula:

FORMULA 2	(BELT PULL)
$BP = [(M + 2W) \times F_w + M_p] \times L + (M \times H)$	

This equation for Belt Pull reflects its two components: $[(M + 2W) \times F_w + M_p] \times L$ for the friction load and $(M \times H)$ for the change in elevation, if one exists.

ADJUSTING THE CALCULATED BELT PULL FOR ACTUAL SERVICE CONDITIONS

Service conditions may vary greatly. The **Belt Pull, BP**, calculated from **Formula 2** should be adjusted to allow for those factors. The **ADJUSTED BELT PULL, ABP**, is determined by applying an appropriate **Service Factor, SF**.

On *bi-directional* or *"pusher"* type conveyors, where the return side belt tension is high, *both* terminal shafts must be considered as Drive Shafts when determining **ADJUSTED BELT PULL**

FORMULA 3	(ADJUSTED BELT PULL)
$ABP = BP \times SF$	
For Pusher Conveyors:	
$ABP = BP \times SF \times 2.2$	

Service Factors can be determined using "Table 6 (SF) SERVICE FACTOR" (page 455).

CALCULATE ALLOWABLE BELT STRENGTH, ABS

Intralox belts have strength ratings, determined at ambient temperature and low speed. Because the strength of plastics generally decreases as their temperature increases, and because the wear rate is directly proportional to speed but inversely proportional to conveyor length, the **RATED BELT STRENGTH, BS**, should be adjusted according to this formula:

FORMULA 4	(ALLOWABLE BELT STRENGTH)
$ABS = BS \times T \times S$	

The *rated* **BELT STRENGTH, BS**, and **STRENGTH FACTOR, S**, may be found on the various **Product Line** pages. If a belt rating is specified for the sprocket material being used and the rating is lower than the belt rating, use the lower rating. The **TEMPERATURE FACTOR, T**, can be found in "Table 7 (T) TEMPERATURE FACTOR". If a **CENTER DRIVE** is used, determine **S** by using the following equation:

$$\begin{aligned} \text{for } S \text{ greater than } 0.6 & \quad S' = 1-2(1-S) \\ \text{for } S \text{ less than } 0.6 & \quad S' = 0.2 \\ \text{then,} & \quad \mathbf{ABS = BS \times T \times S'} \end{aligned}$$

DETERMINE THE MAXIMUM SPACING OF DRIVE SHAFT SPROCKETS AND RECOMMENDED MINIMUM NUMBER OF SHAFT SPROCKETS

To determine the number of sprockets needed, you must first determine the belt pull in relation to the available strength of the belt. Using the **ADJUSTED BELT PULL** and **ALLOWABLE BELT STRENGTH** calculate the **ALLOWABLE BELT STRENGTH UTILIZED** using this formula.

FORMULA 5	(ALLOWABLE BELT STRENGTH UTILIZED)
$ABSU = (ABP \div ABS) \times 100\%$	

Refer to the graph for the appropriate belt in Section 2 labeled "Sprocket Quantity as a Function of Belt Strength Utilized." Use the **ALLOWABLE BELT STRENGTH UTILIZED, ABSU**, to find the minimum sprocket spacing in inches (or

meters). The number of drive sprockets required for a conveyor is determined by dividing the belt width in inches (or meters) by the sprocket spacing and round up to the next whole number.

Idle Shaft sprockets on conventional conveyors normally are exposed to less tension than drive sprockets and, therefore, may operate with wider spacing. However, this spacing should never exceed 6.0 in (152 mm) for all Series except Series 200 where the maximum spacing should never exceed 7.5 in. (190 mm). Specific recommendations for the *minimum* number of Idle Shaft sprockets can be found in the appropriate sprocket sections of the "Section two: Product line" pages.

If the calculated **ABSU** is above 75%, please contact Intralox Customer Service Sales Engineering to run the Intralox Engineering Program and verify your results.

CONFIRMATION OF SHAFT STRENGTH

Two important functions of the drive shaft, which must be analyzed before its ability to operate properly can be determined, are: (1) its ability to absorb the *bending force* of belt pull with an acceptable shaft deflection, and (2) its ability to transmit the necessary *torque* from the driver without failure.

The initial step here is to make a *preliminary* selection of a shaft size which fits your sprocket of choice. The shaft will bend or deflect under the combined loads of the **ADJUSTED BELT PULL, ABP**, and its own **WEIGHT**. It is assumed these forces are co-planar and can be combined into a **TOTAL SHAFT LOAD, w**, determined by:

FORMULA 6	(TOTAL SHAFT LOAD)
$w = (ABP + Q) \times B$	

The **SHAFT WEIGHT, Q**, can be found from "Table 8 SHAFT DATA" (page 457). **B** represents the width of your belt.

SHAFT DEFLECTION

For shafts supported by *two bearings*, the **DEFLECTION, D**, can be found from:

FORMULA 7	(SHAFT DEFLECTION — 2 BEARINGS)
$D = \frac{5}{384} \times \frac{w \times L_s^3}{E \times I}$	

MODULUS OF ELASTICITY (E) and **MOMENT OF INERTIA (I)** values can be found in "Table 8 SHAFT DATA" (page 457) **L_s** is the *unsupported span* of the shaft between bearings.

MAXIMUM SHAFT DEFLECTION RECOMMENDATIONS

As the drive shaft bends or deflects under heavy loads, the *longitudinal distance* between the drive shaft and the idler shaft is *less at the centerline of the belt than at its edges*. This causes an uneven distribution of tension in the belt, the greatest being absorbed at the edges. Since the tension distribution is uneven, the load absorbed by the sprocket teeth is not equal. Intralox has determined that satisfactory performance can be obtained

if shaft deflections do not exceed certain limits. These limits are:

CONVENTIONAL, UNI-DIRECTIONAL CONVEYORS

Maximum Shaft Deflection = 0.10 in. (2.5 mm)

BI-DIRECTIONAL OR “PUSHER” CONVEYORS

Maximum Shaft Deflection = 0.22 in. (5.6 mm)

If the *preliminary* shaft selection results in excessive deflection it will be necessary to pick a larger shaft size, a stronger material or use intermediate bearings to reduce shaft span.

DEFLECTIONS WITH INTERMEDIATE BEARINGS

With a *third bearing*, located in the center of the shaft, the deflection formula to be used is:

FORMULA 8	(SHAFT DEFLECTION — 3 BEARINGS)
	$D_3 = \frac{1}{185} \times \frac{w}{2} \times \frac{L_S^3}{E \times I}$
	$D_3 = \frac{w \times L_S^3}{370 \times E \times I}$

In this case, L_S is the span between the center bearing and an outer bearing.

In cases involving very wide belts under heavy loads, it may be necessary to use *more than one* intermediate bearing to reduce deflections to an acceptable level. Since the formulas for deflections in these cases become complex and unwieldy, the designer can determine a *safe, maximum span length* for the **TOTAL SHAFT LOAD, w**, from **Tables 12-A, 12-B, 12-C, and 12-D** (page 459).

In using these charts the designer is reminded to first calculate the **TOTAL SHAFT LOAD, w**, (**Formula 6**). In the case of Bi-directionals and Pusher Conveyors, the **ADJUSTED BELT PULL, ABP**, must also be corrected for the increased tension required. See **Formula 5** for the corrected **ABP**.

DRIVE SHAFT TORQUE

The drive shaft must also be strong enough to transmit the twisting or rotating forces imposed by the drive motor to overcome the resistance of moving the belt and the product. The torsional action introduces shearing stresses on the shaft, usually most critical in the bearing journals adjacent to the driver.

Rather than require the designer to calculate the shearing stresses, “*Table 9 MAXIMUM RECOMMENDED TORQUE ON DRIVE SHAFT*” (page 457) has been developed to quickly determine the **MAXIMUM RECOMMENDED DRIVE SHAFT TORQUE** for a given shaft journal diameter and shaft material. For example, assume your preliminary shaft selection is 2.5 in. (63.5 mm) and made of Carbon Steel. Since the *maximum* journal diameter is 2.5 in. (63.5 mm), the maximum recommended torque for *this* size is 22,500 in-lb (259,000 kg-mm).

The actual **TORQUE, T_o** , to be transmitted can be calculated from:

FORMULA 9	(TORQUE, DRIVE SHAFT)
	$T_o = ABP \times B \times \frac{P.D.}{2}$
	where P.D. represents your sprocket's Pitch Diameter, in. (mm).

Compare the *actual* torque with the *maximum recommended* torque to determine if this journal size is adequate. If not, try the next larger shaft size or a stronger material. If these are not possible, try a smaller sprocket size.

In many cases, the actual torque will be considerably lower than the maximum recommended. If so, reducing the journal diameter to an acceptable smaller size will reduce the cost of bearings required.

DETERMINING THE POWER NEEDED TO DRIVE THE BELT

The **POWER** needed to overcome the resistance of moving the belt and product can be calculated from these formulas:

FORMULA 10	(HORSEPOWER — ENGLISH [USA] UNITS)
	$\text{HORSEPOWER, HP} = \frac{ABP \times B \times V}{33,000}$
where:	ABP = Adjusted Belt Pull, lb/ft of belt width B = Belt Width, ft. V = Belt Speed, ft/min

Another version using different factors is:

FORMULA 11	(HORSEPOWER — ENGLISH [USA] UNITS)
	$\text{HORSEPOWER, HP} = \frac{T_o \times V}{16,500 \times P.D.}$
where:	T_o = Torque, in-lb P.D. = Pitch Diameter, in. V = Belt Speed, ft/min

FORMULA 12	(POWER — METRIC UNITS)
	$\text{POWER, WATTS} = \frac{ABP \times B \times V}{6.12}$
where:	ABP = Adjusted Belt Pull, kg/m of belt width B = Belt Width, m. V = Belt Speed, m/min

and another version is:

FORMULA 13	(POWER — METRIC UNITS)
	$\text{POWER, WATTS} = \frac{T_o \times V}{3.06 \times P.D.}$
where:	T_o = Torque, kg-mm P.D. = Pitch Diameter, mm V = Belt Speed, m/min

If Torque is known in *Newton-millimeters* the equation for Power is:

FORMULA 14	(POWER — SI UNITS)
	$\text{POWER, WATTS} = \frac{T_o \times V}{30 \times \text{P.D.}}$
where:	$T_o = \text{Torque, N-mm}$

DETERMINING DRIVE MOTOR POWER REQUIREMENTS

The power calculated to drive the belt does not include the power to overcome the friction in gears, bearings, chains and other mechanical parts of the system. Refer to "Section three: Design guidelines" (page 423), for a listing of efficiency losses in components in common use and increase the belt drive power accordingly.

THERMAL EXPANSION (CONTRACTION) OF MATERIALS

As materials experience increases or decreases in temperature, their dimensions increase or decrease likewise. Conveyor belts which are installed at one temperature and operate at another, or which pass through different temperatures in their operating circuit, will expand or contract accordingly. Since plastics have relatively high rates of expansion (contraction), this characteristic must be considered in the application of these belts if significant temperature changes are expected.

The change in the length, width or thickness of a material can be determined from:

FORMULA 15	(THERMAL EXPANSION OR CONTRACTION)
	$\Delta = L_1 \times (T_2 - T_1) \times e$
where:	$\Delta = \text{change in dimension, in. (mm)}$ $L_1 = \text{dimension at initial temperature, ft. (m)}$ $T_2 = \text{operating temperature, } ^\circ\text{F (} ^\circ\text{C)}$ $T_1 = \text{initial temperature, } ^\circ\text{F (} ^\circ\text{C)}$ $e = \text{coefficient of thermal expansion, in/ft}^\circ\text{F (mm/m}^\circ\text{C)}$

Coefficients of Thermal Expansion of various materials may be found on page 443.

CATENARY SAG (see discussion in Section 3)

A belt hanging under the influence of gravity between two supports will assume the shape of a curve called a "catenary". The specific dimensions of this curve will depend upon the distance between supports, the length of hanging belt and the belt's weight.

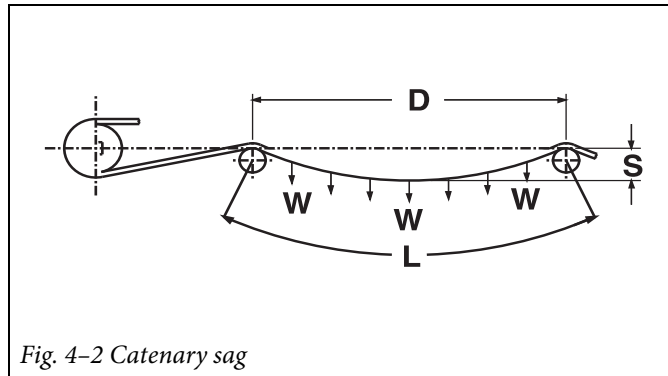

Fig. 4-2 Catenary sag

In most cases, the actual shape of this curve is not important, but the conveyor designer is interested in two things: the excess belt required and the tension created by the sagging belt.

The excess belt, **X**, or the difference between **L** and **D** in the above illustration is found from:

FORMULA 16	(EXCESS BELT —CATENARY SAG)
	$X = \frac{2.66 \times S^2}{D}$
where:	$X = \text{excess belt, ft. (m)}$ $S = \text{sag, ft. (m)}$ $D = \text{distance between supports, ft. (m)}$

The tension, **T**, created by a catenary section of belt, is found from:

FORMULA 17	(TENSION —CATENARY SAG)
English System	
	$T = \frac{d^2 \times W}{96 \times s}$
where:	$T = \text{tension, lb/ft. of belt width}$ $s = \text{sag, in.}$ $d = \text{distance between supports, in.}$ $W = \text{belt weight, lb/ft}^2$
Metric System	
	$T = \frac{d^2 \times W}{8000 \times s}$
where:	$T = \text{tension, kg/m of belt width}$ $s = \text{sag, mm}$ $d = \text{distance between supports, mm}$ $W = \text{belt weight, kg/m}^2$

Note: RADIUS BELTS

Formulas for radius belts are provided on a PC based Flat-Turn Program for radius applications. Call Customer Service to request a diskette.

SAMPLE PROBLEMS

STEEL CAN HANDLING EXAMPLE

CONDITIONS (IN METRIC UNITS):

A beverage handler proposes to use **Series 400 Raised Rib** Polypropylene belting to carry steel cans, weighing **122 kg per square meter**, on a conveyor which is **18.3 m** long and **1.2 m** wide. The belt will run wet on UHMW wearstrips at a speed of **6 m** per minute, frequent starts under load are expected and the steel cans will “back-up” a total of **15.2 m**. The operating temperature is to be **82 °C**. A 12 tooth, **198 mm** pitch diameter is preferred, and Carbon Steel shafts are acceptable.

STEP 1: Determine the BACKED-UP PRODUCT LOAD, M_p (Formula 1)

$$M_p = M \times F_p \times \left(\frac{\text{Percentage of Belt Area Backed-Up}}{100} \right)$$

The **COEFFICIENT OF FRICTION, F_w** , between the belt and the UHMW wearstrips, is determined from “Table 2 (F_w) COEFFICIENT OF START-UP FRICTION BETWEEN WEARSTRIP & BELT” (page 454) to be 0.11. The **COEFFICIENT OF FRICTION, F_p** , between the steel cans and the belt, is found from “Table 3 (F_p) COEFFICIENT OF RUNNING FRICTION BETWEEN CONTAINER & BELT” (page 454) to be 0.26.

Since the steel cans will be backed-up **15.2 m**, the **percentage of BELT AREA BACKED-UP** is

$$\frac{15.2}{18.3} \text{ or } 83.1\%$$

Then the **BACKED-UP PRODUCT LOAD, M_p** , is:

$$M_p = 122 \times 0.26 \times \left(\frac{83.1}{100} \right)$$

$$M_p = 26.4 \text{ kg/m}^2$$

STEP 2: Calculate BELT PULL, BP , (Formula 2)

$$BP = [(M + 2W) \times F_w + M_p] \times L + (M \times H)$$

M = Product Loading (**122 kg/m²**)

W = Belt Weight (**9.52 kg/m²**)

L = Conveyor Length (**18.3 m**)

M_p = Backed-Up Product Load (**26.4 kg/m²**)

H = Elevation Change (zero)

Note: Since there is no elevation change, disregard the factor $M \times H$ in the formula.

Therefore:

$$BP = [(122 + (2 \times 9.52)) \times 0.11 + 26.4] \times 18.3$$

$$BP = 767 \text{ kg/m of belt width}$$

STEP 3: ADJUSTED BELT PULL, ABP (Formula 3)

$$ABP = BP \times SF$$

The **Service Factor, SF** , is determined from “Table 6 (SF) SERVICE FACTOR” (page 455) to be 1.2.

Then:

$$ABP = 767 \times 1.2$$

$$ABP = 920 \text{ kg/m of belt width}$$

STEP 4: CALCULATE THE ALLOWABLE BELT STRENGTH, ABS (Formula 4)

$$ABS = BS \times T \times S$$

The **rated BELT STRENGTH, BS** , can be found from “Table 4 BELT STRENGTHS IN lb/ft (kg/m).” (page 454) to be **3,570 kg/m** of width.

With the operating temperature of **82 °C**, the **TEMPERATURE FACTOR, T** , found from “Table 7 (T) TEMPERATURE FACTOR” (page 456) is 0.48.

To determine the **STRENGTH FACTOR, S** , first calculate the **SPEED/LENGTH** ratio of 6.0/18.3 or 0.33. From page 50, **S** is 1.0.

Then:

$$ABS = 3,570 \times 0.48 \times 1.0$$

$$ABS = 1,714 \text{ kg/m of belt width}$$

Since the **ABS** exceeds **ABP**, this belt is strong enough for this application.

STEP 5: MAXIMUM SPACING OF DRIVE SHAFT SPROCKETS

$$ABSU = (ABP \div ABS) \times 100\%$$

$$ABSU = (920 \div 1,714) \times 100\%$$

$$ABSU = 54\%$$

From page 49, the **MAXIMUM SPROCKET SPACING** should be about **70 mm**.

STEP 6: DETERMINE DRIVE SHAFT DEFLECTION

Since this is a fairly wide belt, first try a **60 mm** square shaft. The **TOTAL SHAFT LOAD, w** , is calculated by:

$$w = (ABP + Q) \times B \quad (\text{Formula 6})$$

From “Table 8 SHAFT DATA” (page 457), find **Q** , the **SHAFT WEIGHT**, to be **29.11 kg/m** of length. Then:

$$w = (920 + 29.11) \times 1.2$$

$$w = 1,139 \text{ kg}$$

For **SHAFT DEFLECTION**, assume first the shaft is to be supported by two bearings. Therefore, the **DEFLECTION, D**, is found from:

$$D = \frac{5}{384} \times \frac{w \times L_s^3}{E \times I} \quad (\text{Formula 7})$$

Since the belt is to be **1.2 m** or **1200 mm** wide, assume the **unsupported LENGTH OF SHAFT, L_s** is **1320 mm**, and from “*Table 8 SHAFT DATA*” (page 457), the **MODULUS OF ELASTICITY, E**, and the **MOMENT OF INERTIA, I**, are found to be **21,100 kg/mm²** and **1,080,000 mm⁴**, respectively. Then:

$$D = \frac{5}{384} \times \frac{1139 \times 1320^3}{21,000 \times 1,080,000}$$

$$D = 1.50 \text{ mm}$$

Since this deflection is less than the recommended limit of **2.5 mm**, supporting it with two bearings is acceptable.

STEP 7: DRIVE SHAFT TORQUE, T_o (Formula 9)

$$T_o = \text{ABP} \times B \times \frac{\text{P.D.}}{2}$$

$$T_o = 920 \times 1.2 \times \frac{198}{2}$$

$$= 109,296 \text{ kg-mm}$$

From the **MAXIMUM RECOMMENDED TORQUE** curve, “*Table 9 MAXIMUM RECOMMENDED TORQUE ON DRIVE SHAFT*” (page 457), we see the maximum torque for a journal diameter of **60 mm** is **180,000 kg-mm**. Therefore, the **minimum** journal diameter in this case should be about **55 mm**.

STEP 8: BELT DRIVE POWER (Formula 10)

$$\text{BELT POWER} = \frac{\text{ABP} \times B \times V}{6.12}$$

$$\text{BELT POWER} = \frac{920 \times 1.2 \times 6.0}{6.12}$$

$$\text{BELT POWER} = 1082 \text{ Watts}$$

STEP 9: DETERMINE DRIVE MOTOR POWER

Assume this conveyor will be driven by an electric motor, through a triple reduction, spur gear reducer, chain and sprockets. The shafts are supported by ball bearings. From the table on page 425, the **total** of the efficiency losses in the machinery components are estimated to be 11%.

The **MOTOR POWER** is found from:

$$\text{MOTOR POWER} = \frac{1082}{100 - 11} \times 100$$

$$= 1216 \text{ Watts}$$

Therefore a **2 kW** motor will be a good choice.

FOOD HANDLING EXAMPLE

CONDITIONS (IN U.S. UNITS):

120,000 lb/hr of raw, washed vegetables (product loading of 10 lb/sq ft) are to be lifted a vertical distance of 15 ft. on an *elevating* conveyor 25 ft. long and 2 ft. wide. The environment is wet, the temperature is ambient and belt speed is to be 75 ft/min. Wearstrip material is UHMW and the pre-selected belt is a **Series 800 Perforated Flat Top** Polypropylene with flights and sideguards. The flight spacing is 8 in. The belt will be started unloaded and run continuously. The preferred sprockets are 10 tooth, 6.5 in. pitch diameter. Stainless Steel (303/304) shafts are required.

STEP 1: DETERMINE THE BACKED-UP PRODUCT LOAD, M_p (Formula 1)

$$M_p = M \times F_p \times \left(\frac{\text{Percentage of Belt Area Backed-Up}}{100} \right)$$

Since there is no product backed-up, disregard **M_p**. From “*Table 2 (F_w) COEFFICIENT OF START-UP FRICTION BETWEEN WEARSTRIP & BELT*” (page 454), **F_w = 0.11**.

STEP 2: BELT PULL, BP (Formula 2)

$$BP = (M + 2W) \times F_w \times L + (M \times H)$$

$$BP = [10 + 2(1.54)] \times 0.11 \times 25 + (10 \times 15)$$

$$BP = 186 \text{ lb/ft of belt width}$$

STEP 3: ADJUSTED BELT PULL, ABP (Formula 3)

$$ABP = BP \times SF$$

Service Factor is 1.4 (See “*Table 6 (SF) SERVICE FACTOR*” (page 455)), *Elevating Conveyor*).

Then:

$$ABP = 186 \times 1.4$$

$$ABP = 260 \text{ lb/ft of belt width}$$

STEP 4: ALLOWABLE BELT STRENGTH, ABS (Formula 4)

$$ABS = BS \times T \times S$$

The **RATED BELT STRENGTH, BS**, is 1,000 lb/ft from “*Table 4 BELT STRENGTHS IN lb/ft (kg/m)*.” (page 454). **TEMPERATURE FACTOR, T**, is 0.98 and **STRENGTH FACTOR, S**, is 0.92. (See “*Table 7 (T) TEMPERATURE FACTOR*” (page 456))

$$ABS = 1,000 \times 0.98 \times 0.92$$

$$ABS = 902 \text{ lb/ft of belt width}$$

Since **ABS** exceeds **ABP**, **Series 800 Perforated Flat Top** Polypropylene belting is adequate for this application.

STEP 5: MAXIMUM SPACING OF DRIVE SHAFT SPROCKETS

$$\begin{aligned} \text{ABSU} &= (\text{ABP} \div \text{ABS}) \times 100\% \\ \text{ABSU} &= (260 \div 902) \times 100\% \\ \text{ABSU} &= 29\% \end{aligned}$$

From page 84, is 6.0 in.

STEP 6: DETERMINE DRIVE SHAFT DEFLECTION

Total Shaft Load, w , is:

$$w = (\text{ABP} + Q) \times B \quad (\text{Formula 6})$$

Pre-select a 1.5 in. square Stainless Steel shaft.
Therefore:

$$\begin{aligned} w &= (260 + 7.65) \times 2 \\ w &= 535 \text{ lb} \end{aligned}$$

and SHAFT DEFLECTION, D , is:

$$D = \frac{5}{384} \times \frac{w \times L_s^3}{E \times I} \quad (\text{Formula 7})$$

Assume L_s is 28 in. From "Table 8 SHAFT DATA" (page 457), E is 28,000,000 lb/in² and I is 0.42 in.⁴.

Therefore:

$$\begin{aligned} D &= \frac{5}{384} \times \frac{535 \times 28^3}{28,000,000 \times 0.42} \\ D &= 0.013 \text{ in.} \end{aligned}$$

which is less than the recommended limit of 0.10 in.

STEP 7: DRIVE SHAFT TORQUE, T_o (Formula 9)

$$\begin{aligned} T_o &= \text{ABP} \times B \times \frac{\text{P.D.}}{2} \\ T_o &= 260 \times 2 \times \frac{6.5}{2} \\ T_o &= 1690 \text{ in-lb} \end{aligned}$$

From "Table 9 MAXIMUM RECOMMENDED TORQUE ON DRIVE SHAFT" (page 457), a torque of 1,690 in/lb requires a *minimum* journal diameter of about 0.85 in. with 303/304 Stainless Steel, therefore, a journal diameter of 1.0 in. is recommended.

STEP 8: BELT DRIVE POWER (Formula 10)

$$\begin{aligned} \text{BELT HORSEPOWER} &= \frac{\text{ABP} \times B \times V}{33,000} \\ \text{BELT HORSEPOWER} &= \frac{260 \times 2 \times 75}{33,000} \\ \text{BELT HORSEPOWER} &= 1.18 \text{ HP} \end{aligned}$$

STEP 9: DETERMINE DRIVE MOTOR POWER

Assume it is determined from page 425, that the total efficiency losses are expected to be 20%. The **MOTOR HORSEPOWER**, then, is found from:

$$\begin{aligned} \text{MOTOR HORSEPOWER} &= \frac{1,18}{100 - 20} \times 100 \\ &= 1,48 \text{ HP} \end{aligned}$$

In this case, a 1.5 HP motor will be a suitable choice.

BI-DIRECTIONAL CONVEYOR EXAMPLE

CONDITIONS (IN METRIC UNITS):

A canning plant accumulator table, measuring 6 m in length and 2.4 m wide, is to handle cans weighing 50 kg/m². Belt speed will be 3.0 m/min. Frequent loaded starts are expected. The belt will operate at 21 °C. The wearstrips are to be Stainless Steel. The belt will run dry. **Series 900 Raised Rib** in Acetal is the preferred belt, using 18 tooth, 156 mm pitch diameter sprockets on 60 mm square shafts of 304 Stainless Steel.

STEP 1: DETERMINE THE BACKED-UP PRODUCT LOAD, M_p (Formula 1)

$$M_p = M \times F_p \times \left(\frac{\text{Percentage of Belt Area Backed-Up}}{100} \right)$$

Since there is no product backed-up, ignore M_p .
 $F_w = 0.19$

STEP 2: CALCULATE BELT PULL, BP (Formula 2)

$$\begin{aligned} BP &= (M + 2W) \times F_w \times L + (M \times H) \\ M &= 50 \text{ kg/m}^2 \\ W &= 8.19 \text{ kg/m}^2 \\ L &= 6 \text{ m} \\ F_w &= 0.19 \\ H &= \text{zero} \end{aligned}$$

$$\begin{aligned} BP &= [50 + 2(8.19)] \times 0.19 \times 6 \\ BP &= 76 \text{ kg/m of width} \end{aligned}$$

STEP 3: CALCULATE ADJUSTED BELT PULL, ABP (Formula 3)

$$\begin{aligned} ABP &= BP \times SF \times 2.2 \\ ABP &= 76 \times 1.2 \times 2.2 \\ ABP &= 201 \text{ kg/m of width} \end{aligned}$$

STEP 4: CALCULATE ALLOWABLE BELT STRENGTH, **ABS** (Formula 4)

$$ABS = BS \times T \times S$$

BS = RATED BELT STRENGTH ("Table 4 BELT STRENGTHS IN lb/ft (kg/m).")

T = 0.98 (see "Table 7 (T) TEMPERATURE FACTOR")

S = 1.0

ABS = $2200 \times 0.98 \times 1.0$

ABS = 2156 kg/m of width

Therefore, since **ABS** exceeds **ABP**, **Series 900 Raised Rib** in Acetal is a suitable choice.

STEP 5: DETERMINE MAXIMUM SPACING OF DRIVE SHAFT SPROCKETS

Since both the carryway and return way sides will be under tension, the idle shafts are to be treated as drive shafts for sprocket spacing and deflection calculations.

$$ABSU = (ABP \div ABS) \times 100\%$$

$$ABSU = (201 \div 2,156) \times 100\%$$

$$ABSU = 9\%$$

From the chart on page 131, the **MAXIMUM SPROCKET SPACING** is 95 mm.

STEP 6: CONFIRM DRIVE SHAFT STRENGTH

Total Shaft Load, w, is:

$$w = (\text{Corrected ABP} + Q) \times B \quad (\text{Formula 6})$$

$$w = (182 + 29.11) \times 2.4$$

$$w = 507 \text{ kg}$$

A check of the **Maximum Drive and Idler Shaft Span Length, Table 11-C** (page 459), reveals that the shaft load of 507 kg applied to a 60 mm square Stainless Steel shaft. This allows a maximum span of about 2600 mm. Since this conveyor is 2.4 m or 2400 mm wide, intermediate bearings should not be required.

CALCULATE DRIVE SHAFT TORQUE, T_o (Formula 9):

$$T_o = ABP \times B \times \frac{P.D.}{2}$$

ABP = 201 kg/m of width

B = 2.4 m of width

P.D. = 156 mm

$$T_o = 201 \times 2.4 \times \frac{156}{2}$$

$$T_o = 37,627 \text{ kg-mm}$$

From the chart of **MAXIMUM RECOMMENDED TORQUE**, the *minimum* journal diameter for a torque of 37,627 kg-mm would be about 27 mm. Since a 60 mm shaft is needed, due to deflection, the journal diameter may be as large as 55 mm, for example.

STEP 7: CALCULATE THE POWER TO DRIVE THE BELT (Formula 10)

$$\text{BELT POWER} = \frac{ABP \times B \times V}{6.12}$$

ABP = 201 kg/m of width (above)

B = 2.4 kg/m width (above)

V = 3.0 m/min (above)

$$\text{BELT POWER} = \frac{201 \times 2.4 \times 3.0}{6.12}$$

$$\text{BELT POWER} = 236 \text{ Watts}$$

STEP 8: CALCULATE DRIVE MOTOR POWER

Refer to page 425, for efficiency losses in mechanical components. Assume the total of the efficiency losses for this conveyor are determined to be about 25%. Therefore, **MOTOR POWER** is:

$$\text{MOTOR POWER} = \frac{236}{100 - 25} \times 100$$

$$= 315 \text{ Watts}$$

Therefore a 1/3 kW motor would be a good selection.

TABLES

Table 1 (W) BELT WEIGHT IN lb/ft² (kg/m²).

SERIES	STYLE	STANDARD MATERIALS			SPECIAL APPLICATIONS MATERIALS ^a
		POLYPROPYLENE	POLYETHYLENE	ACETAL & HSEC ACETAL	

This information is incorporated into the charts for each Series and belt style.

Table 2 (F_w) COEFFICIENT OF START-UP FRICTION BETWEEN WEARSTRIP & BELT

WEARSTRIP MATERIAL	STANDARD MATERIALS ^a									
	POLYPROPYLENE				POLYETHYLENE		ACETAL		HSEC ACETAL	
	SMOOTH SURFACE		ABRASIVE ^b SURFACE		SMOOTH SURFACE		SMOOTH SURFACE		SMOOTH SURFACE	
	WET	DRY	WET	DRY	WET	DRY	WET	DRY	WET	DRY
U.H.M.W.	0.11	0.13	NR	NR	0.24	0.32 ^c	0.10	0.10	0.10	0.10
H.D.P.E.	0.09	0.11	NR	NR	NR	NR	0.09	0.08	0.09	0.08
Molybdenum- or Silicon-filled Nylon	0.24	0.25	0.29	0.30	0.14	0.13	0.13	0.15	0.13	0.15
Cold-Rolled Finish Stainless or Carbon Steel	0.26	0.26	0.31	0.31	0.14	0.15	0.18	0.19	0.18	0.19

a. For Special Applications Materials see appropriate data pages.

b. Based on Intralox tests.

c. Increased wear may be experienced at belt speeds above 50 feet per minute (15 meter/min).

Table 3 (F_p) COEFFICIENT OF RUNNING FRICTION BETWEEN CONTAINER & BELT^a

CONTAINER MATERIAL	STANDARD MATERIALS ^b							
	POLYPROPYLENE		POLYETHYLENE ^c		ACETAL		HSEC ACETAL	
	WET	DRY	WET	DRY	WET	DRY	WET	DRY
Glass	0.18	0.19	0.08	0.09	0.13	0.14	0.13	0.14
Steel	0.26	0.32	0.10	0.13	0.13	0.13	0.19	0.20
Plastic	0.11	0.17	0.08	0.08	0.13	0.16	0.13	0.16
Cardboard	—	0.21	—	0.15	—	0.18	—	0.18
Aluminum	0.40	0.40	0.20	0.24	0.33	0.27	0.33	0.27

Note: Belts operating dry on a backed-up conveyor may, depending on speed and weight, wear a rough surface on the belting, which may substantially increase the Coefficient of Friction.

a. Friction factor values are highly dependent on environmental conditions. The low value of the friction factor range is an experimentally derived friction factor for new belting on new wearstrip. This value should only be used in the cleanest environments or where water or other lubricating agents are present. Most applications should be adjusted based on the environmental conditions surrounding the conveyor.

b. For Special Applications Materials see appropriate data pages.

c. Polyethylene generally not recommended for container handling.

Table 4 BELT STRENGTHS IN lb/ft (kg/m).

SERIES	STYLE	STANDARD MATERIALS			SPECIAL APPLICATIONS MATERIALS
		POLYPROPYLENE	POLYETHYLENE	ACETAL & HSEC ACETAL	

This information is incorporated into the charts for each Series and belt style.

Table 5 SPROCKET AND SUPPORT QUANTITY REFERENCE

Nominal Width ^a in. (mm)	Minimum Number of Sprockets Per Shaft ^b				Minimum Number of Supports			
	SERIES 200	SERIES 1700	SERIES 100, 400, 800, 850, 1200, 1400, 1800, 1900	SERIES 900, 1100, 1500, 1600, 2200	SERIES 100, 900, 1000, 1100, 1400, 1500, 1600, 1650		SERIES 200, 400, 800, 850, 1200, 1800, 1900, 2200, 2400	
					Carryway	Returnway	Carryway	Returnway
2 (51)	1	N/A	1	1	2	2	2	2
4 (102)	1	N/A	1	1	2	2	2	2
6 (152)	2	2	2	2	2	2	2	2
7 (178)	2	2	2	2	3	2	2	2
8 (203)	2	2	2	2	3	2	2	2
10 (254)	2	3	2	3	3	2	3	2
12 (305)	3	3	3	3	3	2	3	2
14 (356)	3	3	3	5	4	3	3	3
15 (381)	3	3	3	5	4	3	3	3
16 (406)	3	4	3	5	4	3	3	3
18 (457)	3	4	3	5	4	3	3	3
20 (508)	3	4	5	5	5	3	4	3
24 (610)	5	5	5	7	5	3	4	3
30 (762)	5	6	5	9	6	4	5	4
32 (813)	5	7	7	9	7	4	5	4
36 (914)	5	8	7	9	7	4	5	4
42 (1067)	7	9	7	11	8	5	6	5
48 (1219)	7	10	9	13	9	5	7	5
54 (1372)	9	11	9	15	10	6	7	6
60 (1524)	9	12	11	15	11	6	8	6
72 (1829)	11	15	13	19	13	7	9	7
84 (2134)	13	17	15	21	15	8	11	8
96 (2438)	13	20	17	25	17	9	12	9
120 (3048)	17	24	21	31	21	11	15	11
144 (3658)	21	29	25	37	25	13	17	13
For Other Widths	Use Odd Number of Sprockets at a Maximum 7.5 in. (191 mm) Spacing	Use Odd Number of Sprockets at a Maximum 5 in. (127 mm) Spacing	Use Odd Number of Sprockets at a Maximum 6 in. (152 mm) Spacing	Use Odd Number of Sprockets at a Maximum 4 in. (102 mm) Spacing	Maximum 6 in. (152 mm) Spacing	Maximum 12 in. (305 mm) Spacing	Maximum 9 in. (229mm) Spacing	Maximum 12 in. (305mm) Spacing

Note:

- If carryways extend into sprocket area, care should be taken to ensure sprockets do not interfere with carryways.
- **These are the minimum number of sprockets. Additional sprockets may be required, see Data Pages for specific applications.**
- Additional quantities can be found in the Sprocket and Support Quantity Reference Table for **Series 1200** on page 179, **Series 1500** on page 214, **Series 1700** on page 237, **Series 2400** on page 327, and **Series 2600** on page 366.

- a. Actual belt widths will vary from nominal. If actual width is critical, contact Customer Service.
 b. Fix center sprocket only. (With two sprockets on shaft, fix right hand sprocket only.)

Table 6 (SF) SERVICE FACTOR

Starts under no load, with load applied gradually		1.0
Frequent starts under load (more than once per hour)	ADD 0.2	_____
At speeds greater than 100 FPM (Feet Per Minute) (30 meters/min)	ADD 0.2	_____
Elevating Conveyors	ADD 0.4	_____
Pusher Conveyors	ADD 0.2	_____
		TOTAL _____

Note: At speeds greater than 50 FPM (15 meters/min) on conveyors that are started with backed-up lines, soft start motors should be considered.

Table 7 (T) TEMPERATURE FACTOR

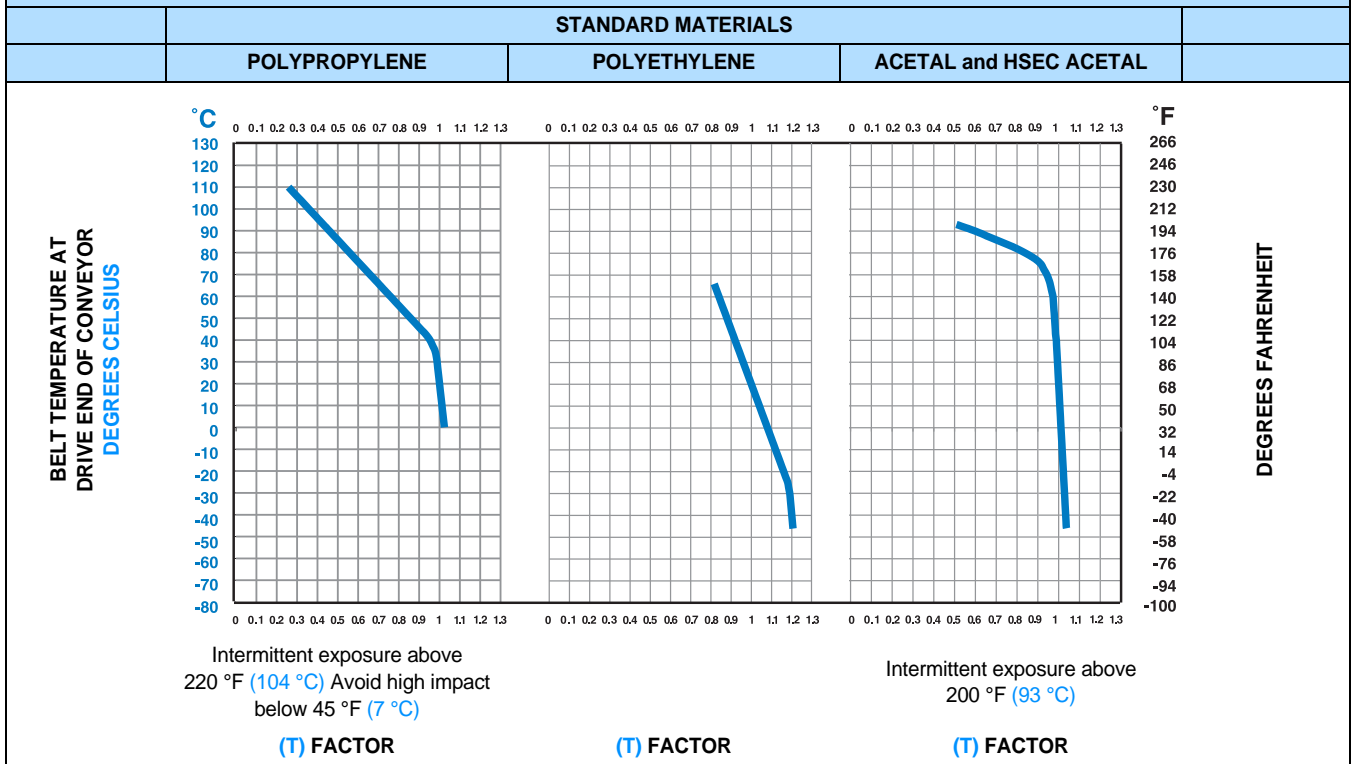

SPECIAL APPLICATION MATERIALS

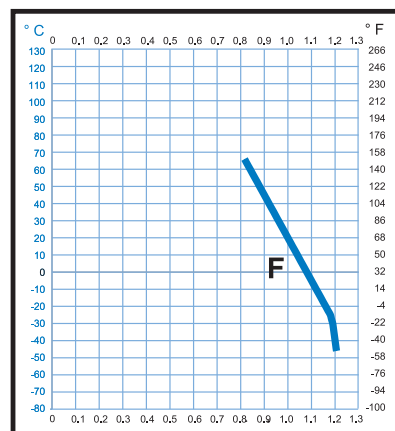
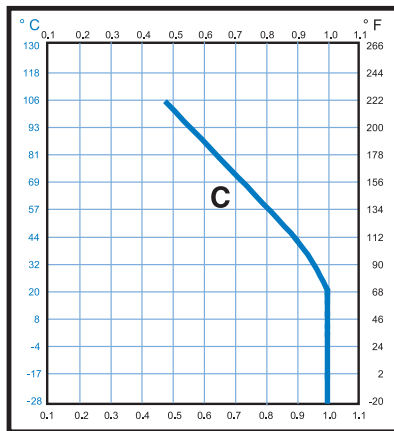
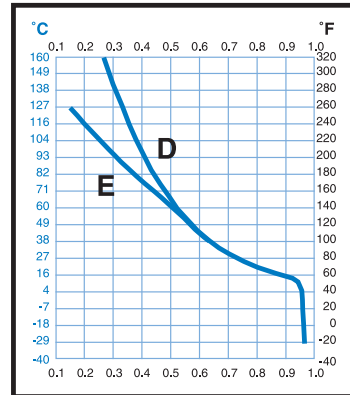
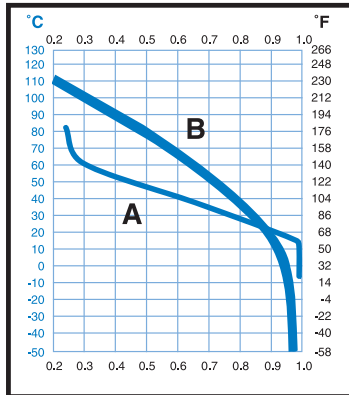

- A - Flame retardant
- B - Nylon, SELM
- C - Polypropylene composite
- D - HHR nylon
- E - HR nylon
- F - Detectable polypropylene

Intermittent exposure above 220 °F (104 °C). Avoid high impact below 45 °F (7 °C)

Table 8 SHAFT DATA				
B-SHAFT DATA	(Q) SHAFT WEIGHT, lb/ft (kg/m)			I MOMENT OF INERTIA in. ⁴ (mm ⁴)
	ALUMINUM	CARBON STEEL	STAINLESS STEEL	
SIZE				
5/8" SQUARE	0.46	1.33 ^a	1.33 ^a	0.013
1" SQUARE	1.17 ^a	3.40 ^a	3.40 ^a	0.083
1.5" SQUARE	2.64 ^a	7.65 ^a	7.65 ^a	0.42
2.5" SQUARE	7.34	21.25 ^a	21.25 ^a	3.25
3.5" SQUARE	14.39	41.60 ^a	41.60	12.50
25 mm SQUARE	(1.699)	(4.920) ^b	(4.920) ^b	(32.550)
40 mm SQUARE	(4.335)	(12.55) ^b	(12.55) ^b	(213,300)
60 mm SQUARE	(10.05)	(29.11) ^b	(29.11) ^b	(1,080,000)
65 mm SQUARE	(11.79)	(34.16) ^b	(34.16) ^b	(1,487,600)
E MODULUS OF ELASTICITY lb/in ² (kg/mm ²)	10,000,000 (7000)	30,000,000 (21,100)	28,000,000 (19,700)	

- a. Intralox USA can supply square shafting machined to specifications in these sizes in Carbon Steel (C-1018), Stainless Steel (303/304 and 316), and Aluminum (6061-T6).
- b. Intralox Europe offers square shafting in these sizes in Carbon Steel (KG-37) and Stainless Steel (304).

Table 9 MAXIMUM RECOMMENDED TORQUE ON DRIVE SHAFT

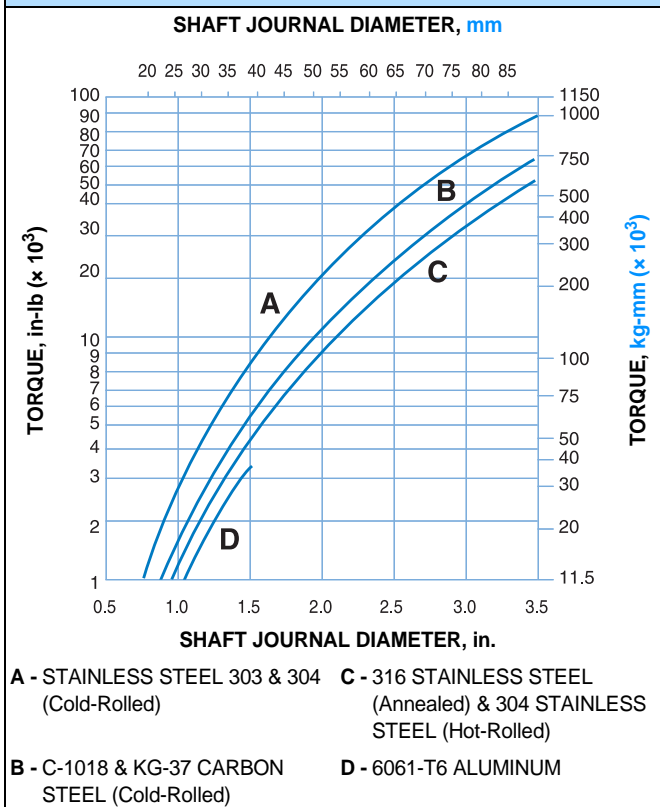

SELECTING THE RECOMMENDED RETAINER RINGS

Intralox recommends the use of retainer rings to fix the location of one sprocket on each shaft to limit transverse movement of the belt during operation. In many applications, spring-type rings are used with success; however these rings require small grooves to be cut into the corners of the shafts. In some applications where belt loads are higher and stresses in the shaft are greater, the presence of ring grooves is undesirable as they create places where stresses are concentrated. **Therefore, it is recommended that alternative retainer rings that require no grooves, such as the SELF-SET or SPLIT COLLAR rings, be used in these cases.**

Refer to the chart below for recommended limits of BELT PULL versus SHAFT SPAN BETWEEN BEARINGS to determine if retainer ring grooves should be used. For a given shaft size and span, if the BELT PULL, BP, exceeds the values shown, select a ring that requires no grooves in the shaft.

Table 10 BELT PULL LIMITS VS SHAFT SPAN FOR RETAINER RING GROOVES

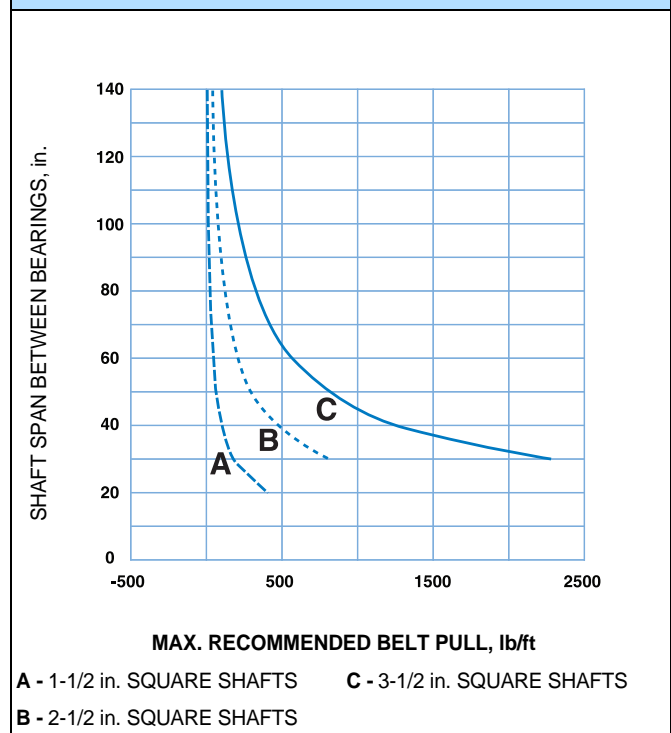
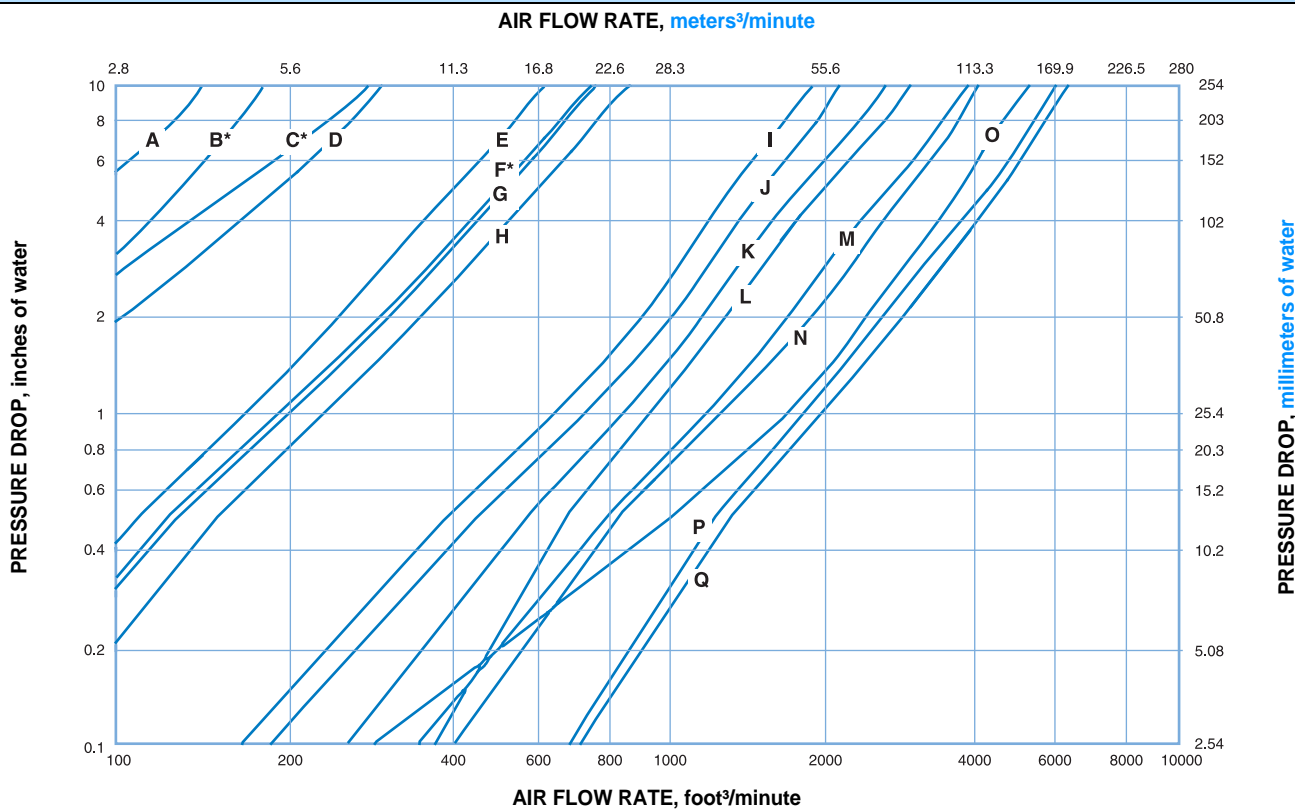

Table 11 AIR FLOW RATE THROUGH BELT, PER SQUARE FOOT OF BELT AREA



- A - S400 Flat Top
- B - S1100 Edge Loss
- C - S1100 Flat Top
- D - S900 Flat Top
- E - S900 Perforated Flat Top Ø 1/8"
- F - S1100 Perforated Flat Top Ø 5/32"
- G - S900 Perforated Flat Top Ø 5/32"
- H - S900 Perforated Flat Top Ø 3/16"
- I - S400 Flush Grid
- J - S800 PFT, S800 PFT Ø 5/32", S2000
- K - S100 Flush Grid
- L - S100 and S400 Raised Rib
- M - S200 Flush Grid, S200 Open Hinge
- N - S1100 Flush Grid
- O - S900 Flush Grid and Raised Rib
- P - S200 Open Hinge
- Q - S2200

***SERIES 1100 FLAT TOP/PERFORATED FLAT TOP EDGE LOSS:**

In order to go around a 0.875 inch nosebar and achieve self-clearing dead plates, the **Series 1100 Flat Top/Perforated Flat Top** belt does not have a sealed edge. To accurately size the fan, both airflow through the belt and edge loss of airflow must be considered. This example describes how to size the fan flow required for the **Series 1100 Perforated Flat Top** belt.

For a 30 inch wide belt that is 10 feet long, under a vacuum of 4 inches of water, the area under vacuum is 25 square feet. The length under vacuum is 10 feet. As per the Airflow Table, at a vacuum of 4 inches of water, airflow is 450 SCFM per square foot through the belt and 110 SCFM per linear foot for the edge. $SCFM = (\text{square feet belt under vacuum} \times \text{airflow through the belt}) + (\text{linear feet belt} \times \text{edge loss})$. Therefore, total flow is $(25 \times 450) + (10 \times 110) = 12,350$ SCFM.

Table 12 MAXIMUM DRIVE SHAFT SPAN LENGTH (CONVENTIONAL CONVEYORS)

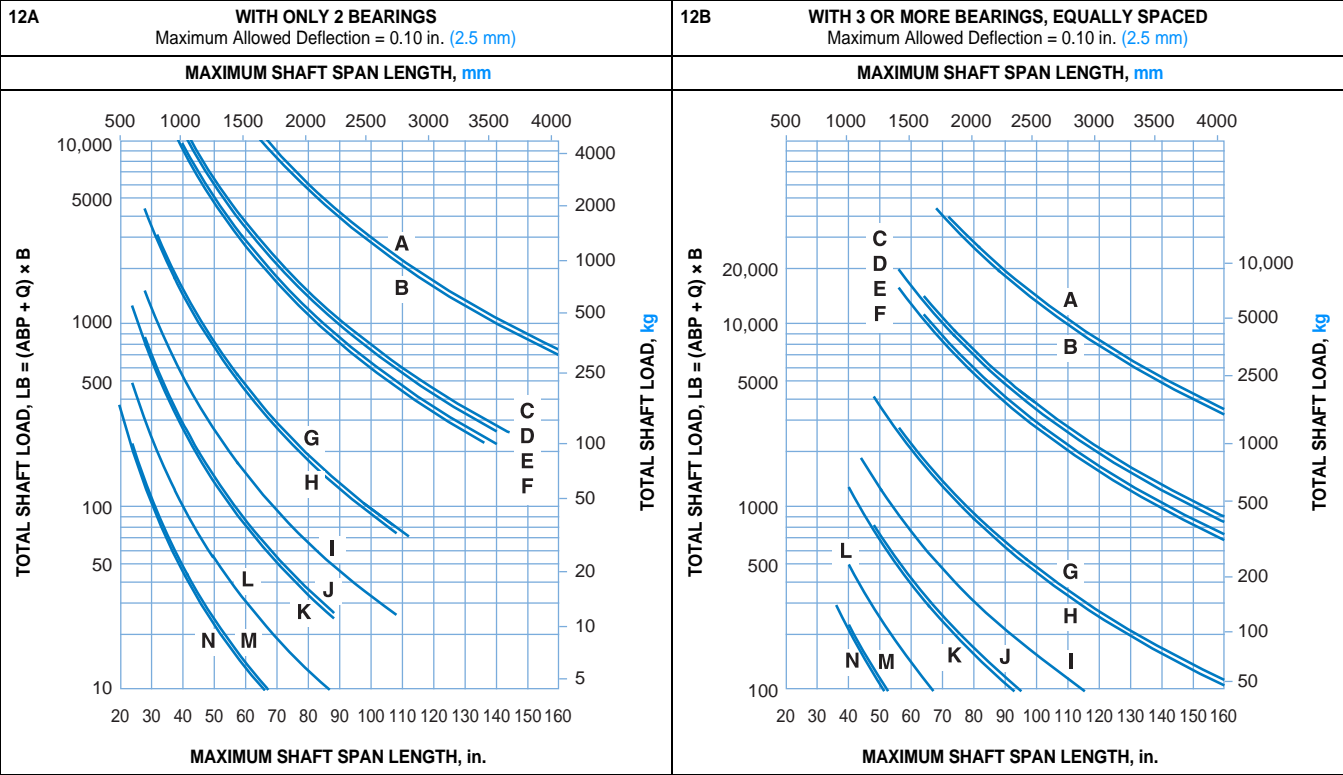

MAXIMUM DRIVE & IDLER SHAFT SPAN LENGTH (BI-DIRECTIONAL & PUSHER CONVEYORS)

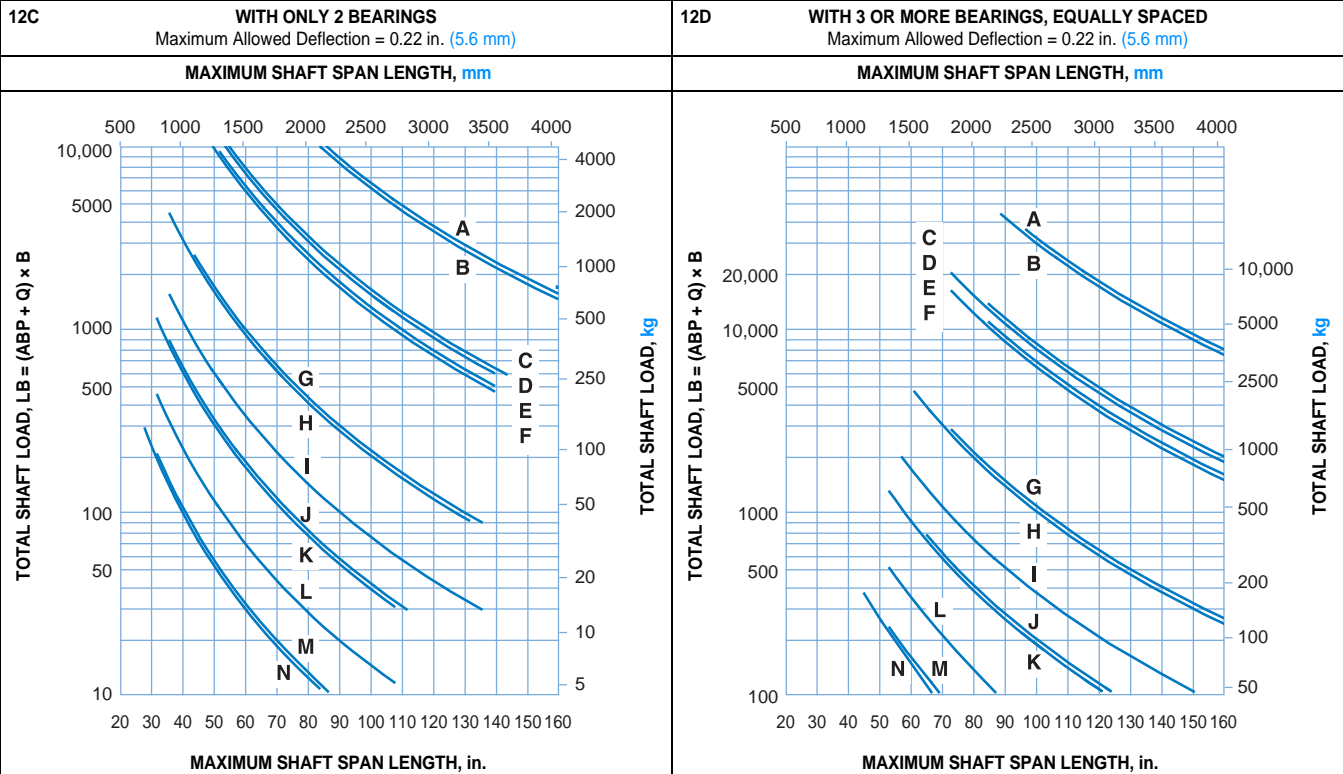

- | | |
|---|---|
| <ul style="list-style-type: none"> A - 3.5" and 90 mm Square Carbon Steel B - 3.5" and 90 mm Square Stainless Steel C - 2.5" and 65 mm Square Carbon Steel D - 2.5" and 65 mm Square Stainless Steel E - 60 mm Square Carbon Steel F - 60 mm Square Stainless Steel G - 1.5" and 40 mm Square Carbon Steel | <ul style="list-style-type: none"> H - 1.5" and 40 mm Square Stainless Steel I - 1.5" Square Aluminum J - 1.0" and 25.4 mm Square Carbon Steel K - 1.0" and 25.4 mm Square Stainless Steel L - 1.0" Square Aluminum M - 5/8" Square Carbon Steel N - 5/8" Square Stainless Steel |
|---|---|

MEASUREMENT CONVERSION FACTORS

ENGLISH (USA) UNIT	MULTIPLY BY →	METRIC (SI) UNIT	MULTIPLY BY →	ENGLISH (USA) UNIT
LENGTH				
inch (in.)	25.40	millimeter (mm)	0.03937	inch (in.)
inch (in.)	0.0254	meter (m)	39.37	inch (in.)
foot (ft.)	304.8	millimeter (mm)	0.0033	foot (ft.)
foot (ft.)	0.3048	meter (m)	3.281	foot (ft.)
AREA				
inch ² (in. ²)	645.2	millimeter ² (mm ²)	0.00155	inch ² (in. ²)
inch ² (in. ²)	0.000645	meter ² (m ²)	1550.0	inch ² (in. ²)
foot ² (ft. ²)	92,903	millimeter ² (mm ²)	0.00001	foot ² (ft. ²)
foot ² (ft. ²)	0.0929	meter ² (m ²)	10.764	foot ² (ft. ²)
VOLUME				
foot ³ (ft. ³)	0.0283	meter ³ (m ³)	35.31	foot ³ (ft. ³)
foot ³ (ft. ³)	28.32	liter (l)	0.0353	foot ³ (ft. ³)
VELOCITY and SPEED				
foot/second (ft/s)	18.29	meter/min (m/min)	0.0547	foot/second (ft/s)
foot/minute (ft/min)	0.3048	meter/min (m/min)	3.281	foot/minute (ft/min)
MASS and DENSITY				
pound-avdp. (lb)	0.4536	kilogram (kg)	2.205	pound-avdp. (lb)
pound/foot ³ (lb/ft ³)	16.02	kilogram/meter ³ (kg/m ³)	0.0624	pound/foot ³ (lb/ft ³)
FORCE and FORCE/LENGTH				
pound-force (lb)	0.4536	kilogram-force (kg)	2.205	pound-force (lb)
pound-force (lb)	4.448	Newton (N)	0.225	pound-force (lb)
kilogram-force (kg)	9.807	Newton (N)	0.102	kilogram-force (kg)
pound/foot (lb/ft)	1.488	kilogram/meter (kg/m)	0.672	pound/foot (lb/ft)
pound/foot (lb/ft)	14.59	Newton/meter (N/m)	0.0685	pound/foot (lb/ft)
kilogram/meter (kg/m)	9.807	Newton/meter (N/m)	0.102	kilogram/meter (kg/m)
TORQUE				
inch-pound (in-lb)	11.52	kilogram-millimeter (kg-mm)	0.0868	inch-pound (in-lb)
inch-pound (in-lb)	0.113	Newton-meter (N-m)	8.85	inch-pound (in-lb)
kilogram-millimeter (kg-mm)	9.81	Newton/millimeter (N-mm)	0.102	kilogram-millimeter (kg-mm)
MOMENT of INERTIA				
inch ⁴ (in. ⁴)	416,231	millimeter ⁴ (mm ⁴)	0.0000024	inch ⁴ (in. ⁴)
inch ⁴ (in. ⁴)	41.62	centimeter ⁴ (cm ⁴)	0.024	inch ⁴ (in. ⁴)
PRESSURE and STRESS				
pound/inch ² (lb/in ²)	0.0007	kilogram/millimeter ² (kg/mm ²)	1422	pound/inch ² (lb/in ²)
pound/inch ² (lb/in ²)	0.0703	kilogram/centimeter ² (kg/cm ²)	14.22	pound/inch ² (lb/in ²)
pound/inch ² (lb/in ²)	0.00689	Newton/millimeter ² (N/mm ²)	145.0	pound/inch ² (lb/in ²)
pound/inch ² (lb/in ²)	0.689	Newton/centimeter ² (N/cm ²)	1.450	pound/inch ² (lb/in ²)
pound/foot ² (lb/ft ²)	4.882	kilogram/meter ² (kg/m ²)	0.205	pound/foot ² (lb/ft ²)
pound/foot ² (lb/ft ²)	47.88	Newton/meter ² (N/m ²)	0.0209	pound/foot ² (lb/ft ²)
POWER				
Horsepower (hp)	745.7	Watt	0.00134	Horsepower (hp)
foot-pound/minute (ft-lb/min)	0.0226	Watt	44.25	foot-pound/minute (ft-lb/min)
TEMPERATURE				
To Convert From		To		Use Formula
Temperature Fahrenheit, °F		Temperature Celsius, °C		°C = (°F - 32) ÷ 1.8
Temperature Celsius, °C		Temperature Fahrenheit, °F		°F = (1.8 x °C) + 32

CHEMICAL RESISTANCE GUIDE

The chemical resistance data is based on information from polymer manufacturers and Intralox field experience. The data is indicative only for the conditions under which it was collected and should be considered as a recommendation only, not as a guarantee. This data pertains to chemical resistance only, and the temperatures listed are generally the chemical application temperatures. Other design and personal safety concerns were not considered in making recommendations. Materials and products should be tested under exact intended service conditions to determine their suitability for a particular purpose.

Chemicals listed without a concentration are for the undiluted chemical. Chemicals listed with a concentration are in solution with water. Descriptions in parentheses are the active ingredient. In general, as the chemical application temperature, chemical concentration, and exposure time rises, the chemical resistance of a material decreases. Additional information about chemicals and materials of construction not listed may be obtained by contacting the Technical Support Group (TSG) at Intralox.

Thermoplastics Elastomers (TPE) are a growing class of polymers that offer a unique combination of plastic and elastomeric properties. The most obvious of these properties is the ability to be injection molded onto a substrate for achieving a performance criteria. The fact that a rubber

(elastomeric) component is present means that exposure to various chemicals in the application must be considered. Sources of chemicals include the product to be conveyed, materials used to clean and maintain the equipment and belt, and any other potential sources in the area. Intralox suggests doing appropriate testing and consulting with our staff of experts early on to establish fitness for use in a particular application. In general, TPEs are compatible with both weak acids, most alkalis, and alcohols. Contact with strong acids poses a problem. Due to a rubber component, oils and fats will have a swelling effect over time. Organic solvents and various hydrocarbons are also expected to cause problems. Generally speaking, fuels of any type will cause problems over time. In food handling applications, ensure that the ingredients present in the food are considered. Also, in food handling, the higher the applied chemical temperature, chemical concentration, and exposure time, the more rapid the reaction between the chemical and the TPE will be.

MATERIAL SUITABILITY CODE

- R = Resistant
- NR = Not Resistant
- LR = Limited Resistance
- = No Available Information

CHEMICAL NAME	STANDARD MATERIALS								SPECIAL APPLICATIONS MATERIALS							
	Polypropylene		Polyethylene		Acetal		HSEC Acetal		Heat Resistant Nylon		Nylon SELM		Flame Retardant Material		Hi-Impact	
	70 °F (21 °C)	140 °F (60 °C)	70 °F (21 °C)	140 °F (60 °C)	70 °F (21 °C)	140 °F (60 °C)	70 °F (21 °C)	140 °F (60 °C)	70 °F (21 °C)	140 °F (60 °C)	70 °F (21 °C)	140 °F (60 °C)	70 °F (21 °C)	140 °F (60 °C)	70 °F (21 °C)	140 °F (60 °C)
Acetic Acid																
Acetic Acid - 5%	R	R	R	R	R	—	R	—	LR	—	LR	NR	R	—	R	—
Acetic Acid - 10%	R	R	R	R	R	—	R	—	R	NR	—	—	R	—	—	—
Acetic Acid - 50%	R	R	R	R	NR	NR	NR	NR	NR	NR	—	—	—	—	—	—
Acetone	R	R	R	R	R	R	R	R	R	—	R	R	NR	NR	NR	NR
Alcohol - All Types	R	R	R	R	—	—	—	—	R	R	R	R	R	R	NR	—
Alum - All Types	R	R	R	R	—	—	—	—	LR	—	—	—	—	—	—	—
Almond Oil	R	R	—	—	—	—	—	—	—	—	—	—	—	—	—	—
Aluminum Alum	R	R	R	R	—	—	—	—	—	—	—	—	—	—	—	—
Aluminum Compounds	R	R	R	R	—	—	—	—	LR	R	R	R	R	R	LR	—
Aluminum Chloride	R	R	R	R	LR	NR	LR	NR	R	—	—	—	R	—	R	R
Aluminum Flouride	R	R	R	R	—	—	—	—	—	—	—	—	—	—	—	—
Aluminum Hydroxide	R	R	R	R	R	R	R	R	R	—	—	—	R	—	R	—
Aluminum Nitrate	R	R	—	—	LR	NR	LR	NR	LR	LR	—	—	R	—	R	—
Aluminum Phosphate	R	R	R	R	—	—	—	—	LR	LR	—	—	—	—	—	—
Aluminum Sulfate	R	R	R	R	LR	NR	LR	NR	LR	LR	R	R	R	—	R	—
Ammonia	R	R	R	R	R	R	R	R	LR	LR	R	R	R	NR	R	—
Ammonium Compounds	R	R	R	R	—	—	R	—	LR	R	R	R	R	R	LR	—
Ammonium Acetate	R	—	R	R	R	—	R	—	—	—	R	R	—	—	R	—
Ammonium Carbonate	R	R	R	R	R	R	R	R	—	—	R	R	—	—	R	—
Ammonium Chloride	R	R	R	R	R	R	LR	R	LR	R	R	R	R	—	R	—
Ammonium Fluoride	R	R	R	R	—	—	—	—	—	—	—	—	—	—	—	—
Ammonium Hydroxide	R	R	—	—	R	R	R	R	—	—	—	—	LR	NR	LR	—
Ammonium Nitrate	R	R	R	R	R	LR	R	LR	R	LR	R	R	R	—	R	—
Ammonium Phosphate	R	R	R	R	R	—	R	—	R	LR	R	R	—	—	—	—
Ammonium Salts	—	—	R	—	R	—	R	—	R	LR	—	—	—	—	—	—
Ammonium Sulphate	R	R	R	R	R	LR	R	LR	R	LR	R	R	R	—	R	—

MATERIAL SUITABILITY CODE

- R = Resistant
- NR = Not Resistant
- LR = Limited Resistance
- = No Available Information

CHEMICAL NAME	STANDARD MATERIALS								SPECIAL APPLICATIONS MATERIALS							
	Polypropylene		Polyethylene		Acetal		HSEC Acetal		Heat Resistant Nylon		Nylon SELM		Flame Retardant Material		Hi-Impact	
	70 °F (21 °C)	140 °F (60 °C)	70 °F (21 °C)	140 °F (60 °C)	70 °F (21 °C)	140 °F (60 °C)	70 °F (21 °C)	140 °F (60 °C)	70 °F (21 °C)	140 °F (60 °C)	70 °F (21 °C)	140 °F (60 °C)	70 °F (21 °C)	140 °F (60 °C)	70 °F (21 °C)	140 °F (60 °C)
Amyl Acetate	NR	NR	R	R	R	—	R	—	R	NR	NR	NR	R	NR	NR	NR
Amyl Chloride	NR	NR	LR	NR	—	—	—	—	—	—	—	—	—	—	NR	NR
Aniline	R	LR	R	R	—	LR	—	LR	LR	—	—	—	LR	—	NR	NR
Anitfreeze	R	R	R	T	—	—	—	—	—	R	R	R	R	R	—	—
Aqua Regia	LR	NR	NR	NR	LR	—	LR	—	NR	NR	NR	NR	NR	NR	NR	NR
Apple Juice	R	R	—	—	—	—	—	—	—	R	R	—	—	—	—	—
Arsenic Acid	R	R	R	R	—	—	—	—	—	—	—	—	—	—	R	—
Asphalt	—	—	R	LR	—	—	—	—	—	R	R	—	—	—	—	—
Barium Compounds	R	R	R	R	—	—	—	—	R	R	R	R	R	R	—	—
Barium Carbonate	R	R	R	R	—	—	—	—	—	—	—	—	—	—	R	—
Barium Chloride	R	R	R	R	R	—	R	—	LR	—	—	—	R	—	—	—
Barium Hydroxide	R	R	R	R	—	—	—	—	—	—	—	—	—	—	R	—
Barium Soap Grease	R	LR	—	—	—	—	—	—	—	—	—	—	—	—	—	—
Barium Sulphate	R	R	R	R	R	—	R	—	LR	—	—	—	R	—	—	—
Battery Acid	R	R	R	R	—	—	—	—	—	—	—	—	—	—	—	—
Beer	R	R	R	R	—	—	—	—	—	R	R	—	—	—	R	—
Benzene	LR	NR	LR	NR	R	R	R	R	R	R	R	R	R	NR	R	—
Benzenesulfonic Acid - 10%	R	R	R	R	—	—	—	—	—	—	—	—	—	—	NR	NR
Benzoic Acid	R	R	R	R	LR	—	LR	—	LR	LR	—	—	R	—	NR	NR
Bone Oil	R	R	R	R	—	—	—	—	—	R	R	—	—	—	—	—
Borax	R	R	R	R	—	—	—	—	—	—	—	—	—	—	—	—
Boric Acid	R	R	R	R	LR	—	LR	—	LR	—	R	R	R	—	R	—
Brake Fluid	R	R	R	R	R	R	R	R	R	—	R	R	R	LR	LR	—
Brine Acid	R	R	—	—	—	—	—	—	—	—	—	—	—	—	—	—
Brine Saturated	R	R	R	R	—	—	—	—	—	—	—	—	—	—	—	—
Brine Water	R	—	—	—	—	—	—	—	—	—	—	—	—	—	—	—
Bromic Acid	NR	NR	NR	NR	—	—	—	—	—	—	—	—	—	—	—	—
Bromine - Liquid or Fumes	NR	NR	NR	NR	—	—	—	—	NR	NR	NR	NR	NR	NR	—	—
Bromine Water	NR	NR	R	—	LR	—	LR	—	NR	NR	NR	NR	NR	NR	—	—
Butter	R	R	R	R	R	—	R	—	LR	—	R	R	R	R	—	—
Butyl Acetate	NR	NR	R	LR	—	—	—	—	R	—	R	R	R	R	NR	NR
Butyl Acrylate	NR	NR	R	LR	—	—	—	—	R	—	—	—	LR	LR	—	—
Butyl Glycol	—	—	R	R	R	LR	R	LR	R	—	—	—	R	R	—	—
Butyric Acid	R	R	R	LR	—	—	—	—	LR	—	—	—	R	—	NR	NR
Calcium Compounds	R	R	R	R	—	—	—	—	LR	—	—	—	R	R	R	—
Calcium Carbonate	R	R	R	R	R	—	R	—	—	—	—	—	—	—	R	—
Calcium Chloride	R	R	R	R	R	—	R	—	R	LR	R	LR	R	—	R	—
Calcium Hydroxide	R	R	R	R	R	—	R	—	R	—	—	—	R	—	NR	NR
Calcium Hypochlorite	R	R	R	R	NR	—	NR	—	NR	NR	—	—	LR	—	R	—
Calcium Nitrate	R	R	R	R	R	—	R	—	—	—	R	R	—	—	R	—
Calcium Phosphate	R	R	R	R	—	—	—	—	—	—	—	—	—	—	—	—
Calcium Soap Grease	R	LR	—	—	—	—	—	—	—	—	—	—	—	—	—	—
Calcium Sulphate	R	R	R	R	R	—	R	—	—	—	—	—	—	—	R	—
Calgonite - 0.3%	R	R	—	—	R	R	R	R	—	—	—	—	—	—	R	—
Carbon Dioxide	R	R	R	R	R	R	R	R	—	—	—	—	R	R	R	—
Carbon Disulfide	LR	NR	LR	NR	R	—	R	—	R	NR	R	—	R	—	NR	NR
Carbon Tetrachloride	LR	NR	NR	NR	R	LR	R	LR	R	R	R	R	R	LR	LR	—
Castor Oil	R	R	R	R	R	—	R	—	—	—	—	—	—	—	R	—
Cellosolve - TM	R	R	R	R	—	—	—	—	—	—	—	—	—	—	NR	NR
Chloroacetic Acid 0-10%	R	R	R	R	NR	NR	NR	NR	NR	NR	NR	NR	NR	NR	NR	NR
Chlorine - Gas	NR	NR	—	—	NR	NR	NR	NR	—	NR	NR	NR	NR	NR	LR	—
Chlorine - Liquid	NR	NR	R	R	NR	NR	NR	NR	NR	NR	NR	NR	NR	NR	NR	NR
Chlorine Water (0.4% Cl)	R	LR	R	LR	NR	NR	NR	NR	—	NR	NR	NR	—	—	NR	—
Chlorobenzene	NR	NR	LR	NR	R	R	R	R	R	R	LR	LR	NR	NR	NR	NR
Chloroform	NR	NR	NR	NR	LR	NR	LR	NR	NR	NR	NR	NR	NR	NR	NR	NR
Chlorosulfonic Acid	NR	NR	NR	NR	NR	NR	NR	NR	NR	NR	NR	NR	NR	NR	NR	NR
Chromic Acid - 10%	R	R	LR	LR	NR	NR	NR	NR	NR	NR	—	—	LR	—	NR	NR
Citric Acid	R	R	R	R	—	—	—	—	—	R	R	—	R	R	R	—
Citric Acid - 10%	R	LR	R	R	LR	NR	LR	NR	LR	—	R	—	R	LR	R	—
Citrus Juices	R	R	R	R	R	—	R	—	—	—	—	—	R	—	—	—

MATERIAL SUITABILITY CODE

R = Resistant
NR = Not Resistant
LR = Limited Resistance
— = No Available Information

CHEMICAL NAME	STANDARD MATERIALS								SPECIAL APPLICATIONS MATERIALS							
	Polypropylene		Polyethylene		Acetal		HSEC Acetal		Heat Resistant Nylon		Nylon SELM		Flame Retardant Material		Hi-Impact	
	70 °F (21 °C)	140 °F (60 °C)	70 °F (21 °C)	140 °F (60 °C)	70 °F (21 °C)	140 °F (60 °C)	70 °F (21 °C)	140 °F (60 °C)	70 °F (21 °C)	140 °F (60 °C)	70 °F (21 °C)	140 °F (60 °C)	70 °F (21 °C)	140 °F (60 °C)	70 °F (21 °C)	140 °F (60 °C)
Clorox - TM	R	R	—	—	—	—	—	—	—	NR	NR	NR	—	—	NR	—
Coconut Oil	R	R	R	R	—	—	—	—	—	—	R	R	—	—	R	—
Coffee	R	R	R	R	—	—	—	—	—	—	R	R	—	—	—	—
Copper Compounds	R	R	R	R	—	—	—	—	LR	—	LR	—	R	R	R	—
Copper Chloride	R	R	R	R	R	—	R	—	LR	—	—	—	R	—	R	—
Copper Fluoride	R	R	R	R	—	—	—	—	—	—	—	—	—	—	—	—
Copper Nitrate	R	R	R	R	R	—	R	—	LR	—	—	—	R	—	R	—
Copper Salts	R	R	R	R	R	—	R	—	LR	—	—	—	R	—	R	—
Copper Sulphate	R	R	R	R	R	R	R	R	LR	—	R	—	R	—	R	—
Corn Oil	R	R	R	LR	—	—	—	—	—	—	R	—	R	—	—	—
Cottonseed Oil	R	R	R	R	—	—	—	—	—	—	—	—	R	—	R	—
Cresol	R	R	R	LR	—	—	—	—	NR	NR	NR	NR	—	—	NR	NR
Crude Oil	—	—	R	LR	R	—	R	—	—	—	—	—	R	NR	—	—
Cyclohexane	R	NR	R	R	R	—	R	—	R	—	R	—	R	—	R	—
Cyclohexanol	R	LR	R	R	R	—	R	—	R	—	—	—	R	—	—	—
Cyclohexanone	R	NR	R	LR	R	—	R	—	R	—	—	—	R	—	N	—
Detergents	R	R	R	R	R	R	R	R	—	—	—	—	R	R	—	—
Dextrin	R	R	R	R	R	—	R	—	—	—	—	—	—	—	—	—
Dibutyl Phthalate	R	LR	R	LR	—	—	—	—	R	R	—	—	R	LR	NR	NR
Diesel Fuel	R	LR	R	LR	R	R	R	R	R	R	R	R	LR	NR	R	—
Diethyl Ether	R	NR	LR	LR	R	R	R	R	R	—	R	—	R	—	NR	NR
Diethylamine	R	R	R	R	—	—	—	—	R	—	—	—	—	—	R	—
Diethylene	R	R	—	—	—	—	—	—	—	—	—	—	—	—	—	—
Diglycolic Acid - 30%	R	R	R	R	—	—	—	—	—	—	—	—	—	—	—	—
Diisooctyl Phthalate	R	R	—	—	—	—	—	—	—	—	—	—	—	—	—	—
Dimethyl Phthalate	R	R	—	—	—	—	—	—	—	—	—	—	—	—	—	—
Dimethylamine	R	R	—	—	—	—	—	—	R	—	—	—	—	—	—	—
Diocetyl Phthalate	R	LR	—	—	—	—	—	—	R	—	—	—	—	—	—	—
Ethyl Acetate	R	LR	R	LR	R	NR	R	NR	R	—	—	—	LR	LR	NR	NR
Ethyl Alcohol (Ethanol)	R	R	R	R	R	R	R	R	R	—	R	—	—	—	LR	LR
Ethyl Ether	LR	LR	LR	LR	—	—	—	—	—	—	—	—	—	—	—	—
Ethylamine	R	R	—	—	—	—	—	—	—	—	—	—	—	—	—	—
Ethylene Chloride	NR	NR	—	—	—	—	—	—	—	—	—	—	—	—	—	—
Ethylene Glycol	R	R	R	R	R	LR	R	LR	R	LR	—	—	R	—	LR	—
Ferric / Ferrous Compounds	R	R	R	R	—	—	—	—	LR	—	—	—	—	—	LR	—
Ferric Chloride	R	R	R	R	R	R	LR	—	LR	—	LR	—	—	—	R	—
Ferrous Chloride	R	R	R	R	R	R	—	—	—	—	—	—	—	—	R	—
Ferric Nitrate	R	R	R	R	—	—	—	—	—	—	—	—	—	—	R	—
Ferrous Nitrate	R	R	—	—	—	—	—	—	—	—	—	—	—	—	—	—
Ferric/Ferrous Sulphate	R	R	R	R	—	—	—	—	—	—	—	—	—	—	R	—
Fertilizers	R	R	R	R	—	—	—	—	—	—	—	—	R	—	—	—
Formaldehyde - 30%	R	R	R	R	R	R	R	R	R	—	R	NR	R	—	NR	NR
Formic Acid - 10%	R	—	R	R	LR	LR	LR	LR	NR	NR	LR	NR	R	LR	NR	NR
Formic Acid - 85%	R	LR	R	R	NR	NR	NR	NR	NR	NR	—	—	LR	NR	NR	NR
Freon	R	LR	R	R	R	R	R	R	R	—	—	—	R	R	—	—
Fuel Oils	R	LR	R	LR	R	—	R	—	R	—	R	R	R	—	R	—
Furfural	—	NR	R	R	R	—	R	—	R	—	—	—	R	—	—	—
Gasoline	R	NR	R	LR	R	R	R	R	R	—	R	R	R	LR	LR	—
Glucose	R	R	R	R	R	—	R	—	—	—	R	R	—	—	R	—
Glycerin	R	R	R	R	R	R	R	R	R	LR	R	R	R	LR	R	—
Glycerol	R	R	—	—	R	LR	R	LR	—	—	R	R	—	—	—	—
n-Heptane	LR	NR	R	LR	R	—	R	—	R	—	R	R	R	R	R	—
Hexane	R	NR	R	LR	R	R	R	R	R	—	R	R	R	R	R	—
Hydrobromic Acid - 10%	R	R	R	R	R	—	LR	—	NR	NR	—	—	LR	—	NR	NR
Hydrochloric Acid	R	R	R	R	NR	NR	NR	NR	NR	NR	NR	NR	LR	LR	NR	—
Hydrochloric Acid - 2%	—	—	R	R	LR	NR	LR	NR	NR	NR	NR	NR	R	—	R	—
Hydrochloric Acid - 10%	R	R	R	R	NR	NR	NR	NR	NR	NR	NR	NR	R	—	—	—
Hydrochloric Acid - 38%	R	LR	R	R	NR	NR	NR	NR	NR	NR	NR	NR	—	—	—	—
Hydrofluoric Acid - 10%	R	R	R	R	NR	NR	NR	NR	NR	NR	NR	NR	LR	NR	NR	NR
Hydrofluoric Acid - 35%	R	R	R	R	NR	NR	NR	NR	NR	NR	—	—	NR	NR	NR	NR

MATERIAL SUITABILITY CODE

R = Resistant
NR = Not Resistant
LR = Limited Resistance
— = No Available Information

CHEMICAL NAME	STANDARD MATERIALS								SPECIAL APPLICATIONS MATERIALS							
	Polypropylene		Polyethylene		Acetal		HSEC Acetal		Heat Resistant Nylon		Nylon SELM		Flame Retardant Material		Hi-Impact	
	70 °F (21 °C)	140 °F (60 °C)	70 °F (21 °C)	140 °F (60 °C)	70 °F (21 °C)	140 °F (60 °C)	70 °F (21 °C)	140 °F (60 °C)	70 °F (21 °C)	140 °F (60 °C)	70 °F (21 °C)	140 °F (60 °C)	70 °F (21 °C)	140 °F (60 °C)	70 °F (21 °C)	140 °F (60 °C)
Hydrofluoric Acid - 50%	R	LR	R	LR	NR	NR	NR	NR	NR	NR	—	—	NR	NR	NR	NR
Hydrogen Peroxide - 3%	R	R	R	R	R	R	R	R	NR	NR	R	R	R	LR	R	—
Hydrogen Peroxide - 30%	R	LR	LR	NR	NR	NR	NR	NR	NR	NR	LR	NR	R	LR	LR	—
Hydrogen Peroxide - 90%	LR	LR	LR	NR	NR	NR	NR	NR	NR	NR	NR	NR	—	—	NR	NR
Hydrogen Sulfide	R	R	R	R	LR	—	LR	—	LR	—	R	R	R	—	R	—
Hydroiodic Acid	NR	NR	—	—	—	—	—	—	—	—	—	—	—	—	NR	—
Igepal	R	R	—	—	—	—	—	—	—	—	—	—	R	—	—	—
Iodine	R	R	R	R	NR	NR	NR	NR	NR	NR	—	—	—	—	R	—
Isobutyl Alcohol	R	R	R	R	—	—	—	—	—	—	—	—	—	—	NR	NR
Isopropyl Alcohol	R	R	R	R	R	R	R	R	R	R	R	R	R	—	R	—
Isooctane	NR	NR	R	—	—	—	—	—	R	R	R	R	—	—	NR	—
Jet Fuel	LR	NR	—	—	R	R	R	R	—	—	—	—	R	—	R	—
Kerosene	R	NR	R	LR	R	R	R	R	—	—	—	—	R	R	R	—
Lactic Acid - 10%	—	—	R	R	R	LR	R	LR	R	NR	R	R	R	—	LR	—
Lactic Acid - 80%	R	R	R	R	R	NR	R	NR	NR	NR	NR	NR	—	—	NR	—
Lactose	R	R	R	R	—	—	—	—	—	—	—	—	—	—	—	—
Lanolin	R	LR	R	R	—	—	—	—	—	—	R	R	—	—	—	—
Lard	—	—	R	R	—	—	—	—	—	—	—	—	—	—	R	—
Lauric Acid	R	R	—	—	—	—	—	—	—	—	—	—	—	—	—	—
Lead Acetate	R	R	R	R	—	—	—	—	R	—	—	—	R	—	R	—
Lemon Oil	LR	NR	R	R	—	—	—	—	—	—	R	—	—	—	R	—
Ligroin	LR	NR	—	—	—	—	—	—	—	—	—	—	—	—	—	—
Lime Sulfur	R	—	—	—	—	—	—	—	—	—	—	—	—	—	—	—
Linseed Oil	R	R	R	R	R	R	R	R	R	—	R	R	—	—	R	—
Lubricating Oil	R	LR	R	LR	R	—	R	—	R	LR	R	R	R	R	R	—
Magnesium Compounds	R	R	R	R	—	—	—	—	LR	—	R	—	—	—	NR	—
Magnesium Carbonate	R	R	R	R	—	—	—	—	—	—	—	—	—	—	R	—
Magnesium Chloride	R	R	R	R	R	—	R	—	R	—	R	—	R	—	R	—
Magnesium Hydroxide	R	R	R	R	R	—	R	—	LR	—	—	—	—	—	R	—
Magnesium Nitrate	R	R	R	R	R	—	R	—	R	—	—	—	R	—	R	—
Magnesium Sulphate	R	R	R	R	R	—	R	—	R	—	—	—	R	—	R	—
Malic Acid	R	LR	R	R	NR	NR	NR	NR	—	—	NR	NR	R	—	R	—
Maple Syrup	R	—	—	—	—	—	—	—	—	—	—	—	—	—	—	—
Manganese Sulfate	R	LR	R	R	—	R	—	R	R	—	R	—	R	—	—	—
Margarine	R	R	R	R	—	—	—	—	—	—	R	R	—	—	—	—
Meat Juices/Sauces	R	R	—	—	—	—	—	—	—	—	—	—	—	—	—	—
Mercuric Compounds	R	R	R	R	—	—	—	—	—	—	—	—	—	—	NR	—
Mercuric Chloride	R	R	R	R	—	—	—	—	NR	NR	R	—	—	—	R	—
Mercury	R	R	R	R	R	—	R	—	R	—	R	R	R	—	R	—
Methyl Alcohol	R	R	R	R	R	R	R	R	LR	—	R	R	NR	NR	LR	—
Methyl Cellosolve	R	—	—	—	—	—	—	—	—	—	—	—	—	—	—	—
Methyl Chloride	NR	NR	LR	—	R	—	R	—	R	—	—	—	—	—	—	—
Methyl Ethyl Ketone	R	R	R	NR	LR	LR	LR	LR	R	—	R	R	NR	NR	LR	—
Methyl Isobutyl Ketone	R	R	R	NR	—	—	—	—	—	—	R	R	—	—	NR	NR
Methylene Chloride	LR	NR	LR	LR	NR	NR	NR	NR	LR	—	NR	NR	NR	NR	NR	NR
Methylsulfuric Acid	R	R	R	R	—	—	—	—	—	—	—	—	—	—	—	—
Milk	R	R	R	R	R	—	R	—	LR	—	R	R	R	—	R	—
Mineral Oil	R	LR	R	LR	R	R	R	R	—	—	R	R	R	R	R	—
Mineral Spirits	R	R	R	—	—	—	—	—	—	—	—	—	—	—	R	—
Molasses	R	R	R	R	—	—	—	—	—	—	—	—	R	—	R	—
Motor Oil	R	NR	R	LR	R	R	R	R	R	—	R	R	R	LR	R	—
Naphtha	R	LR	R	LR	R	—	R	—	R	—	R	R	R	—	R	—
Nickel Compounds	R	R	R	R	—	—	—	—	LR	—	LR	—	—	—	—	—
Nickel Chloride	R	R	R	R	R	—	R	—	R	—	—	—	R	—	R	—
Nickel Nitrate	R	R	R	R	—	—	—	—	R	—	R	R	R	—	R	—
Nickel Sulfate	R	R	R	R	R	—	R	—	R	—	R	R	R	—	R	—
Nitric Acid - 10%	R	R	R	R	NR	NR	NR	NR	NR	NR	NR	NR	R	LR	NR	NR
Nitric Acid - 30%	R	R	R	R	NR	NR	NR	NR	NR	NR	NR	NR	NR	NR	NR	—
Nitric Acid - 50%	NR	NR	LR	NR	NR	NR	NR	NR	NR	NR	NR	NR	NR	NR	NR	NR
Nitric Acid - Fuming	NR	NR	NR	NR	NR	NR	NR	NR	NR	NR	NR	NR	NR	NR	NR	—

MATERIAL SUITABILITY CODE
 R = Resistant
 NR = Not Resistant
 LR = Limited Resistance
 — = No Available Information

CHEMICAL NAME	STANDARD MATERIALS								SPECIAL APPLICATIONS MATERIALS							
	Polypropylene		Polyethylene		Acetal		HSEC Acetal		Heat Resistant Nylon		Nylon SELM		Flame Retardant Material		Hi-Impact	
	70 °F (21 °C)	140 °F (60 °C)	70 °F (21 °C)	140 °F (60 °C)	70 °F (21 °C)	140 °F (60 °C)	70 °F (21 °C)	140 °F (60 °C)	70 °F (21 °C)	140 °F (60 °C)	70 °F (21 °C)	140 °F (60 °C)	70 °F (21 °C)	140 °F (60 °C)	70 °F (21 °C)	140 °F (60 °C)
Nitrobenzene	R	LR	NR	LR	LR	—	LR	—	LR	NR	LR	LR	R	—	NR	NR
Nitrous Acid	LR	LR	—	—	—	—	—	—	—	—	—	—	—	—	—	—
Nut Oil	LR	LR	—	—	—	—	—	—	—	—	—	—	—	—	—	—
Nutmeg	NR	NR	R	R	—	—	—	—	—	—	—	—	—	—	—	—
Nitrous Oxide	R	—	—	—	—	—	—	—	—	—	—	—	—	—	R	—
Oleic Acid	R	LR	R	LR	R	—	R	—	R	R	R	NR	R	R	R	—
Olive Oil	R	R	R	R	—	—	—	—	—	—	R	R	—	—	—	—
Orange Oil	R	—	—	—	—	—	—	—	—	—	R	R	—	—	—	—
Oxalic Acid - 10%	R	R	R	R	NR	NR	NR	NR	LR	NR	R	LR	R	R	—	—
Oxalic Acid - 50%	R	R	R	R	NR	NR	NR	NR	—	—	—	—	—	—	NR	—
Oxygen (Atmospheric Pressure)	R	R	R	R	R	—	R	—	R	R	R	R	R	—	R	—
Ozone	LR	NR	LR	NR	NR	NR	NR	NR	NR	NR	R	—	LR	NR	R	—
Palm Nut Oil	R	—	R	—	—	—	—	—	—	—	R	R	—	—	—	—
Palmitic Acid	R	R	R	R	—	—	—	—	R	—	R	—	R	R	R	—
Peanut Oil	R	LR	R	R	—	—	—	—	—	—	R	R	—	—	—	—
Peppermint Oil	R	NR	R	R	—	—	—	—	—	—	R	—	—	—	—	—
Perchloric Acid - 20%	R	R	R	R	NR	NR	NR	NR	—	—	NR	NR	—	—	NR	NR
Perchloroethylene	NR	NR	NR	NR	—	—	—	—	LR	NR	LR	NR	—	—	—	—
Peroxyacetic Acid	R	R	—	—	NR	NR	NR	NR	NR	NR	LR	NR	—	—	R	—
Phthalic Acid - 50%	R	R	R	R	—	—	—	—	—	—	—	—	—	—	—	—
Phenol	R	R	R	R	NR	NR	NR	NR	NR	NR	NR	NR	NR	NR	NR	—
Phenol - 5%	R	R	R	LR	NR	NR	NR	NR	LR	NR	NR	NR	NR	NR	NR	NR
Phosphoric Acid - 10%	R	R	R	R	NR	NR	NR	NR	NR	NR	NR	NR	NR	NR	NR	NR
Phosphoric Acid - 30%	R	R	R	R	NR	NR	NR	NR	NR	NR	NR	NR	NR	NR	NR	NR
Phosphoric Acid - 50%	R	R	R	R	NR	NR	NR	NR	NR	NR	NR	NR	NR	NR	NR	NR
Phosphoric Acid - 85%	R	R	R	LR	NR	NR	NR	NR	NR	NR	NR	NR	NR	NR	NR	NR
Photographic Solutions	R	R	LR	LR	R	—	R	—	—	—	R	R	R	R	R	—
Pineapple Juice	R	R	R	R	—	—	—	—	—	—	—	—	—	—	—	—
Plating Solutions	R	R	R	R	—	—	—	—	—	—	—	—	—	—	NR	NR
Potassium Compounds	R	R	R	R	—	—	—	—	R	—	—	—	R	R	NR	—
Potassium Carbonate	R	R	R	R	R	—	R	—	—	—	R	R	—	—	R	—
Potassium Chlorate	R	R	R	R	—	—	—	—	—	—	R	LR	—	—	—	—
Potassium Chloride	R	R	R	R	R	R	R	R	R	R	R	R	R	LR	R	—
Potassium Hydroxide	R	R	R	R	LR	—	LR	—	R	—	R	R	R	R	R	—
Potassium Iodine	R	—	R	R	—	—	—	—	—	—	R	R	—	—	R	—
Potassium Iodide (3% Iodine)	R	R	R	R	—	—	—	—	—	—	—	—	—	—	NR	—
Potassium Permanganate	R	R	R	R	R	—	R	—	NR	NR	NR	NR	R	LR	NR	NR
Potassium Sulfate	R	R	R	R	R	R	R	R	—	—	R	R	—	—	R	—
Silicone	R	R	R	R	—	—	—	—	—	—	—	—	—	—	—	—
Silicone Oil	R	R	R	R	R	R	R	R	R	R	R	R	R	R	R	—
Silver Cyanide	R	R	—	—	—	—	—	—	—	—	—	—	—	—	—	—
Silver Nitrate	R	R	R	R	—	—	—	—	R	—	—	—	—	—	R	—
Sodium Compounds	R	R	R	R	—	—	R	R	LR	—	—	—	R	R	R	—
Sodium Acetate	R	R	R	R	R	R	R	R	—	—	R	R	—	—	R	—
Sodium Bicarbonate	R	R	R	R	R	R	R	R	—	—	R	R	—	LR	R	—
Sodium Bisulfate	R	R	R	R	R	—	R	—	—	—	R	—	R	—	R	—
Sodium Bisulfite	R	R	R	R	NR	NR	NR	NR	—	—	R	LR	R	LR	—	—
Sodium Borate	R	—	R	R	R	—	R	—	—	—	R	R	—	—	R	—
Sodium Bromide	R	R	R	R	—	—	—	—	LR	—	—	—	—	—	—	—
Sodium Carbonate	R	R	R	R	R	R	R	R	R	—	R	R	R	LR	R	—
Sodium Chlorate	R	R	R	R	R	R	R	R	R	—	R	LR	—	—	R	—
Sodium Chloride	R	R	R	R	—	—	—	—	R	—	R	LR	R	—	R	—
Sodium Cyanide	R	R	R	R	R	—	R	—	R	—	—	—	—	—	NR	NR
Sodium Fluoride	R	R	R	R	—	—	—	—	—	—	—	—	—	—	R	—
Sodium Hydroxide	R	R	R	R	—	—	R	R	R	NR	NR	NR	LR	LR	LR	—
Sodium Hydroxide - 10%	R	R	R	R	R	R	R	R	LR	NR	R	R	R	—	R	—
Sodium Hydroxide - 50%	R	R	R	R	LR	—	LR	—	NR	NR	R	R	—	—	NR	—
Sodium Hypochlorite - (5% Cl)	R	LR	R	—	NR	NR	NR	NR	LR	NR	R	NR	LR	NR	R	—

MATERIAL SUITABILITY CODE

R = Resistant
 NR = Not Resistant
 LR = Limited Resistance
 — = No Available Information

CHEMICAL NAME	STANDARD MATERIALS								SPECIAL APPLICATIONS MATERIALS								
	Polypropylene		Polyethylene		Acetal		HSEC Acetal		Heat Resistant Nylon		Nylon SELM		Flame Retardant Material		Hi-Impact		
	70 °F (21 °C)	140 °F (60 °C)	70 °F (21 °C)	140 °F (60 °C)	70 °F (21 °C)	140 °F (60 °C)	70 °F (21 °C)	140 °F (60 °C)	70 °F (21 °C)	140 °F (60 °C)	70 °F (21 °C)	140 °F (60 °C)	70 °F (21 °C)	140 °F (60 °C)	70 °F (21 °C)	140 °F (60 °C)	
Sodium Hypochlorite - (12.5% Cl)	R	LR	LR	NR	NR	NR	NR	NR	NR	NR	NR	—	NR	LR	NR	—	—
Sodium Nitrate	R	R	R	R	R	R	R	R	R	—	R	R	R	—	R	—	—
Sodium Phosphate	R	—	R	R	R	—	R	—	—	—	R	R	—	—	—	—	—
Sodium Chlorite	R	LR	R	R	—	—	R	R	LR	NR	NR	NR	R	R	LR	—	—
Sodium Hydroxide	R	R	R	R	—	—	R	R	R	NR	NR	NR	LR	LR	LR	—	—
Sodium Hydroxide - 60%	R	R	R	R	R	R	R	R	R	NR	NR	NR	LR	LR	LR	—	—
Sodium Hypochlorite	R	LR	—	—	NR	NR	NR	NR	NR	—	LR	—	R	R	NR	—	—
Stannic Chloride	R	R	R	R	—	—	—	—	—	—	—	—	—	—	LR	—	—
Stannous Chloride	R	R	R	R	—	—	—	—	—	—	R	R	—	—	R	—	—
Starch	R	R	R	R	—	—	—	—	—	—	R	R	—	—	—	—	—
Starch Syrup	R	R	R	R	—	—	—	—	—	—	—	—	—	—	—	—	—
Stearic Acid	R	—	R	LR	R	—	R	—	R	—	R	NR	R	—	R	—	—
Succinic Acid	R	R	R	R	—	—	—	—	—	—	—	—	—	—	—	—	—
Sucrose	R	R	R	R	—	—	—	—	—	—	—	—	—	—	—	—	—
Sugar	R	R	R	R	—	—	—	—	—	—	R	R	—	—	—	—	—
Sulfamic Acid - 20%	R	NR	—	—	—	—	—	—	—	—	—	—	—	—	—	—	—
Sulfate Liquors	R	R	—	—	—	—	—	—	—	—	—	—	—	—	—	—	—
Sulfur	R	R	R	R	R	—	R	—	R	—	R	—	—	—	—	—	—
Sulfur Chloride	R	—	—	—	—	—	—	—	—	—	—	—	—	—	NR	NR	—
Sulfur Dioxide	R	R	R	R	NR	—	NR	—	R	LR	R	R	R	—	LR	—	—
Sulfuric Acid - 3%	R	R	R	R	LR	—	LR	—	NR	NR	NR	NR	R	R	R	—	—
Sulfuric Acid - 50%	R	R	R	R	NR	NR	NR	NR	NR	NR	NR	NR	R	—	—	—	—
Sulfuric Acid - 70%	R	LR	R	LR	NR	NR	NR	NR	NR	NR	NR	NR	—	—	—	—	—
Sulfuric Acid - Fuming	NR	NR	NR	NR	NR	NR	NR	NR	NR	NR	NR	NR	LR	LR	—	—	—
Sulfurous Acid	R	LR	R	R	—	—	—	—	LR	—	—	—	R	—	R	—	—
Tallow	R	R	R	R	R	—	R	—	—	—	—	—	R	—	—	—	—
Tannic Acid - 10%	R	R	R	R	—	—	—	—	—	—	—	—	—	—	NR	NR	—
Tartaric Acid	R	R	R	R	R	—	R	—	R	LR	R	LR	R	—	R	—	—
Tetrahydrofuran	R	LR	NR	NR	LR	—	LR	—	R	—	R	NR	LR	NR	NR	NR	—
Toluene	R	NR	LR	NR	R	R	R	R	R	R	R	R	R	R	NR	NR	—
Tomato Juice	R	R	R	R	—	—	—	—	—	—	R	R	—	—	—	—	—
Transformer Oil	R	NR	R	LR	—	—	—	—	R	—	R	R	R	R	—	—	—
Tributyl Phosphate	R	LR	—	—	—	—	—	—	—	—	—	—	—	—	R	—	—
Trichloroacetic Acid	R	R	R	R	NR	NR	NR	NR	NR	NR	—	—	NR	NR	NR	NR	—
Trichloroethylene	R	NR	—	—	NR	NR	NR	NR	—	—	—	—	—	—	—	—	—
Tricresyl Phosphate	R	LR	—	—	—	—	—	—	—	—	—	—	—	—	—	—	—
Trisodium Phosphate	R	R	R	R	—	—	—	—	—	—	—	—	—	—	R	—	—
Turpentine Oil	R	NR	LR	NR	R	—	R	—	R	—	R	LR	R	—	—	—	—
Urea	R	R	R	R	R	—	R	—	R	—	R	R	R	—	R	—	—
Varnish	R	—	R	R	—	—	—	—	—	—	—	—	—	—	—	—	—
Vaseline	R	R	LR	LR	R	—	R	—	R	—	R	R	R	—	—	—	—
Vegetable Oil			R	LR	R	—	R	—	—	—	—	—	R	R	—	—	—
Vinegar	R	R	R	R	R	—	R	—	—	—	R	LR	—	—	R	—	—
Wine	R	R	R	—	R	—	R	—	—	—	R	LR	R	—	—	—	—
Xylene	NR	NR	LR	NR	R	R	R	R	R	R	R	R	LR	NR	NR	NR	—
Zinc Compounds	R	R	R	R	—	—	—	—	LR	—	LR	—	R	R	LR	—	—
Zinc Carbonate	R	R	R	R	—	—	—	—	—	—	—	—	—	—	—	—	—
Zinc Chloride	R	R	R	R	R	—	R	—	NR	NR	R	R	R	—	R	—	—
Zinc Oxide	R	R	R	R	—	—	—	—	—	—	—	—	—	—	—	—	—
Zinc Sulfate	R	R	R	R	—	—	—	—	LR	—	R	R	R	—	R	—	—

MATERIAL SUITABILITY CODE
R = Resistant
NR = Not Resistant
LR = Limited Resistance
— = No Available Information

STRAIGHT RUNNING BELT DATA SHEET

Company Name: _____	Phone: _____
Mailing Address: _____	Fax: _____
Shipping Address: _____	Dist. Mgr: _____
City & State: _____ Zip: _____	New Installation: _____
Contact: _____ Title: _____	Retrofit Existing: _____

I. PRODUCT CHARACTERISTICS: Product Being Conveyed

<input type="checkbox"/> Plastic	<input type="checkbox"/> Cooked	<input type="checkbox"/> Frozen	<input type="checkbox"/> Cardboard	<input type="checkbox"/> Seasoning	<input type="checkbox"/> Marinade
<input type="checkbox"/> Wet	<input type="checkbox"/> Aluminum	<input type="checkbox"/> Steel	<input type="checkbox"/> Sticky	<input type="checkbox"/> Raw	<input type="checkbox"/> Sauce
<input type="checkbox"/> Dry	<input type="checkbox"/> Slippery	<input type="checkbox"/> Glass	<input type="checkbox"/> USDA-FSIS Req'd	<input type="checkbox"/> Crumbly	
<input type="checkbox"/> Fresh	<input type="checkbox"/> Abrasive	<input type="checkbox"/> Sharp	<input type="checkbox"/> FDA Req'd	<input type="checkbox"/> Other: _____	
<input type="checkbox"/> Corrosive: _____	Compound _____	Concentration _____	Temperature _____		

II. SANITATION:

Method of Cleaning: _____	Frequency: _____
Cleaning Chemicals: _____	Concentration (%): _____
Temperature of Cleaning Media: _____	Time Belt Exposed: _____
Belt Scrapers: _____	Finger Transfer Plates: _____
	Brushes: _____

III. APPLICATION DATA:

Width (in. or mm) _____	Length ϕ - ϕ (ft. or m) _____	Carryway Material:
		<input type="checkbox"/> UHMW <input type="checkbox"/> HDPE <input type="checkbox"/> Nylon
Product Load (lb/ft ² or kg/m ²) _____	Belt Speed (ft. or m/min.) _____	<input type="checkbox"/> Steel <input type="checkbox"/> Other
Sprocket PD (in. or mm) _____	Bore Size (in. or mm) _____	% of belt backed-up with product _____
Temp @ Drive (°F or °C) _____	Shaft Material _____	Push Conveyor? _____
Drive Journal Diameter (in. or mm) _____		Center Drive? _____
Carryway Conditions: <input type="checkbox"/> Wet <input type="checkbox"/> Dry <input type="checkbox"/> Abrasive		Frequent Starts? _____
Nosebar? Static or Dynamic		Elevation Change (ft. or m) _____

IV. BELT STYLE: SERIES (Check One)

	100	200	400	800	850	900	1000	1100	1200	1400	1500	1600	1650	1700	1800	1900	2200	2400	2600	2700	2800	3000	4000	9000		
Flat Top			<input type="checkbox"/>	<input type="checkbox"/>		<input type="checkbox"/>	<input type="checkbox"/>	<input type="checkbox"/>	<input type="checkbox"/>	<input type="checkbox"/>		<input type="checkbox"/>			<input type="checkbox"/>			<input type="checkbox"/>					<input type="checkbox"/>			
Flat Top - Cone Top				<input type="checkbox"/>				<input type="checkbox"/>																		
Flat Top - Cone Open Hinge				<input type="checkbox"/>																						
Flat Top - Embedded Diamond Top								<input type="checkbox"/>																		
Flat Top - Mesh Top				<input type="checkbox"/>		<input type="checkbox"/>						<input type="checkbox"/>			<input type="checkbox"/>											
Flat Top - Mesh Nub Top												<input type="checkbox"/>			<input type="checkbox"/>											
Flat Top - Mini-Rib				<input type="checkbox"/>								<input type="checkbox"/>														
Flat Top - Non-Skid			<input type="checkbox"/>							<input type="checkbox"/>	<input type="checkbox"/>															
Flat Top - Nub Top				<input type="checkbox"/>		<input type="checkbox"/>						<input type="checkbox"/>														
Flat Top - Open Hinge				<input type="checkbox"/>								<input type="checkbox"/>			<input type="checkbox"/>											
Flat Top - Perforated				<input type="checkbox"/>		<input type="checkbox"/>	<input type="checkbox"/>																			
Flat Top - Tough				<input type="checkbox"/>																						
Flush Grid	<input type="checkbox"/>	<input type="checkbox"/>	<input type="checkbox"/>	<input type="checkbox"/>		<input type="checkbox"/>	<input type="checkbox"/>	<input type="checkbox"/>	<input type="checkbox"/>	<input type="checkbox"/>	<input type="checkbox"/>			<input type="checkbox"/>			<input type="checkbox"/>	<input type="checkbox"/>	<input type="checkbox"/>	<input type="checkbox"/>	<input type="checkbox"/>		<input type="checkbox"/>	<input type="checkbox"/>		
Flush Grid - High Deck																	<input type="checkbox"/>	<input type="checkbox"/>								
Flush Grid - Nub Top				<input type="checkbox"/>		<input type="checkbox"/>	<input type="checkbox"/>							<input type="checkbox"/>												
Flush Grid - Open Hinge		<input type="checkbox"/>	<input type="checkbox"/>																							
Flush Grid with Insert Rollers						<input type="checkbox"/>	<input type="checkbox"/>										<input type="checkbox"/>	<input type="checkbox"/>								
Friction Top - Diamond/Square						<input type="checkbox"/>				<input type="checkbox"/>														<input type="checkbox"/>		
Friction Top - Flat						<input type="checkbox"/>	<input type="checkbox"/>			<input type="checkbox"/>																
Friction Top - Round				<input type="checkbox"/>																	<input type="checkbox"/>					
Friction Top - Oval										<input type="checkbox"/>																
Friction Top - Flush Grid								<input type="checkbox"/>								<input type="checkbox"/>	<input type="checkbox"/>									
Knuckle Chain																							<input type="checkbox"/>			
Mold-To-Width						<input type="checkbox"/>	<input type="checkbox"/>	<input type="checkbox"/>		<input type="checkbox"/>	<input type="checkbox"/>							<input type="checkbox"/>						<input type="checkbox"/>		
ONEPIECE™ Live Transfer						<input type="checkbox"/>	<input type="checkbox"/>	<input type="checkbox"/>		<input type="checkbox"/>	<input type="checkbox"/>															
Open Grid		<input type="checkbox"/>				<input type="checkbox"/>																				
Raised Rib	<input type="checkbox"/>		<input type="checkbox"/>	<input type="checkbox"/>		<input type="checkbox"/>										<input type="checkbox"/>		<input type="checkbox"/>								
Raised Rib - Non-Skid								<input type="checkbox"/>																		

V. BELT MATERIAL

Detectable Polypropylene	<input type="checkbox"/>
Electrically Conductive	<input type="checkbox"/>
HR Nylon	<input type="checkbox"/>
Flame Retardant	<input type="checkbox"/>
Hi-Impact	<input type="checkbox"/>
HHR Nylon	<input type="checkbox"/>
Polyacetal	<input type="checkbox"/>
Polyethylene	<input type="checkbox"/>
Polypropylene	<input type="checkbox"/>
Polypropylene Composite	<input type="checkbox"/>
PVDF	<input type="checkbox"/>

RADIUS BELT DATA SHEET

Company Name: _____	Phone: _____
Mailing Address: _____	Fax: _____
Shipping Address: _____	Dist. Mgr: _____
City & State: _____ Zip: _____	New Installation: _____
Contact: _____ Title: _____	Retrofit Existing: _____

I. APPLICATION DATA: Product Being Conveyed: _____

Number of Turns? (4 max) _____

Length of Straight Run #1 (ft. or m) _____

Inside Radius of Turn #1 (in. or mm) _____

What is the Turn Angle in Degrees of Turn #1 _____

Turn Direction of Turn #1 (right or left) _____

Length of Straight Run #2 (ft. or m) _____

Inside Radius of Turn #2 (in. or mm) _____

What is the Turn Angle in Degrees of Turn #2 _____

Turn Direction of Turn #2 (right or left) _____

Length of Straight Run #3 (ft. or m) _____

Inside Radius of Turn #3 (in. or mm) _____

What is the Turn Angle in Degrees of Turn #3 _____

Turn Direction of Turn #3 (right or left) _____

Length of Straight Run #4 (ft. or m) _____

Inside Radius of Turn #4 (in. or mm) _____

What is the Turn Angle in Degrees of Turn #4 _____

Turn Direction of Turn #4 (right or left) _____

Length of Final Straight Run (ft. or m) _____

Belt Width (in. or mm) _____ Belt Material: _____

Carryway Material (UHMW or Steel) _____

Turn Rail Material (UHMW, steel or roller) _____

Does Product Back Up On Belt? _____ % of Belt Backed Up _____

Belt Speed (ft. or m/min) _____ Belt Loading (lb/ft² or kg/m²) on Conveyor _____

Elevation Change (ft. or m) _____ Incline _____ Decline _____

Where: _____

Operating Temp _____ Product Temp (at infeed) _____

Product Size _____ Product Wt/Piece _____

Pcs/ft² or Pcs/m² _____

Sketch/Notes
<p><i>(Indicate Drive Location)</i></p>

PRODUCT CHARACTERISTICS		
<input type="checkbox"/> Plastic	<input type="checkbox"/> Cardboard	<input type="checkbox"/> Wet
<input type="checkbox"/> Aluminum	<input type="checkbox"/> Glass	<input type="checkbox"/> Fresh
<input type="checkbox"/> Steel	<input type="checkbox"/> Sauce	<input type="checkbox"/> Slippery
	<input type="checkbox"/> Frozen	<input type="checkbox"/> Abrasive
	<input type="checkbox"/> Marinade	<input type="checkbox"/> Seasoning
	<input type="checkbox"/> Cooked	<input type="checkbox"/> Raw
	<input type="checkbox"/> Dry	<input type="checkbox"/> Crumbly
	<input type="checkbox"/> Corrosive	<input type="checkbox"/> Sticky
	<input type="checkbox"/> USDA-FSIS Req'd	<input type="checkbox"/> Sharp

II. SANITATION:

Method of Cleaning:	_____	Frequency:	_____
Cleaning Chemicals:	_____	Concentration (%):	_____
Temperature of Cleaning Media:	_____	Time Belt Exposed:	_____
Belt Scrapers:	_____	Finger Transfer Plates:	_____
		Brushes:	_____

Fax this page to Intralox Customer Service for a free analysis of your design using Series 2200, Series 2400, Series 2600, Series 2700, Series 2800, Series 3000, and/or Series 4000 belts.

A

ACCUMULATION TABLES: Conveyors that absorb temporary product overflows due to fluctuations in downstream operations. They may be uni-directional or bi-directional.

ACETAL: A thermoplastic that is strong, has a good balance of mechanical and chemical properties, and has good fatigue endurance and resilience. It has a low coefficient of friction. Temperature range is from -50 °F (-45 °C) to +200 °F (93 °C). Its specific gravity is approximately 1.40.

ADJUSTED BELT PULL: The belt pull adjusted for Service Factors.

ALLOWABLE BELT STRENGTH: The rated belt strength adjusted for Temperature and Strength Factors.

B

BELT PITCH: center distance between hinge rods in an assembled belt.

BELT PULL: The tensile load on a belt after the product loading, belt weight, conveyor length, total friction factor and elevation change is applied.

BRICKLAYED: Belt construction where plastic modules are staggered with those in adjacent rows.

C

CATENARY SAG: A belt or chain hanging under the influence of gravity between two (2) supports will assume the shape of a curve called a “catenary”.

CENTER-DRIVEN BELTS: Belts driven by the sprocket at a point midway between the hinge rods.

CHEVRON CARRYWAYS: Support rails which are placed in an overlapping “V” pattern. This array supports the conveyor belt across the full width while distributing the wear more evenly. This pattern is very effective when moderate abrasion is present, providing a self cleaning method.

CHORDAL ACTION: The pivoting action of the belt’s modules about their hinge rods as the modules engage and disengage the sprocket. This results in a pulsation in the belt’s speed, and a rise and fall in the belt’s surface.

COEFFICIENTS OF FRICTION: A ratio of frictional force to contact force, which is determined experimentally. Coefficients of friction are usually stated for both dry and lubricated surfaces, and for start-up and running conditions.

D

DEAD PLATE GAP: Gap or clearance between the surface of a conveyor belt and any other surface onto which products or containers being conveyed are to be transferred.

DEFLECTION: Displacement or deformation due to loading.

E

ELEVATING CONVEYORS: These conveyors have several types of variations and are employed when product elevation is necessary. Elevators almost always employ flights and sideguards, which present special consideration in the design.

EXTRA-WIDE SPROCKETS: Available only in a **Series 200**, hinge-driven, diameter sprocket. Provides an extra-wide (double) driving area.

F

F.D.A.: Food and Drug Administration. Federal agency which regulates materials that may come in contact with food products.

FINGER TRANSFER PLATES: Comb-like plates that are employed with Intralox Raised Rib belts to minimize problems with product transfer and tipping.

FLAT PLATE CARRYWAYS: These are continuous sheets, usually of metal, over which the belt slides.

FLAT TOP STYLE: Modular plastic belt with a smooth, closed surface.

FLIGHTS: A vertical surface across the width of the belt. An integral part of the Intralox belt, employed where elevation of product is required (e.g., *Incline Conveyors, Elevator Conveyors*).

FLUID COUPLINGS: A device which allows the driven conveyor to accelerate gradually to operating speeds. Fluid couplings are recommended when frequent starts and stops of high speed or heavily loaded conveyors occur, and they also serve as an overload safety.

FLUSH GRID STYLE: Modular plastic belt with a smooth, open grid.

FRICTION: The force which acts between two bodies at their surface of contact, so as to resist their sliding on each other (*see Coefficients of Friction*).

G

GRAVITY TAKE-UP: Usually consists of a roller resting on the belt in the returnway, its weight providing the tension needed to maintain proper sprocket engagement. It is most

effective when placed near the drive shaft end of the returnway.

H

H.D.P.E.: High Density Polyethylene resin used in the manufacture of wearstrip. Employed, where abrasion is not a problem, to reduce friction between belt and the carryway surface.

HINGE RODS: Plastic rods that are used in the assembly of modular plastic belts. They also serve as the hinges around which the belt modules rotate.

HINGE-DRIVEN BELTS: Belts driven at the hinges by the sprocket.

HORSEPOWER:

English (USA) Units — The power delivered by a machine while doing work at the rate of 550 foot pounds per second (ft-lb/sec), or 33,000 foot pounds per minute (ft-lb/min). The watt and kilowatt are power units used in rating electrical equipment. One kilowatt is equal to 1,000 watts. One horsepower equals 746 watts or 0.746 kilowatts. One kilowatt (kW) is equal to 1.341 horsepower.

Metric Units — The power delivered by a machine while doing work at the rate of 75 kilogram-meters per second (kg-m/sec), or 4500 kilogram-meters per minute (kg-m/min). One kilowatt (kW) is equal to 1.359 metric horsepower. One metric horsepower equals 736 watts or 0.736 kilowatts and closely approximates one English (USA) Horsepower, 746 watts.

Where calculations in this manual are done in metric units, power calculations are computed in Watts. Wherever Horsepower (HP) is used, it refers to the English (USA) value.

I

IDLER ROLLERS: Steel or plastic pipes that are supported by stub shafts used in place of idle shafts and sprockets. These pipe rollers may be considerably stiffer than a length of solid square shaft of comparable weight.

INERTIA: The tendency of a body to remain at rest or to stay in motion, unless acted upon by an outside force.

INTERMEDIATE BEARINGS: An additional bearing (or bearings) located near the center of a shaft to reduce shaft deflection to an acceptable level.

K

KNUCKLE CHAIN: Narrow chain with relatively high strength that is commonly used in multiple strand applications. Knuckle Chain typically handles boxes, totes, pans or other large products.

L

LOAD-BEARING ROLLERS: Steel or plastic pipes supported by stub shafts which provide stiffness. Employed on center-drive Accumulation Conveyors on either side of the drive shaft.

M

MODULAR CONSTRUCTION: Injection-molded plastic modules assembled into an interlocked unit and joined together by hinge rods.

MODULE PITCH: The distance between the rod hole centerlines on a module.

MODULES: Injection-molded plastic parts used in the assembly of an Intralox belt.

MOLYBDENUM-FILLED NYLON (NYLATRON): A type of wearstrip plastic.

MOMENT OF INERTIA: A characteristic of the shape of an object which describes its resistance to bending or twisting.

N

NYLATRON: (see *Molybdenum-filled Nylon*).

O

ONEPIECE™ LIVE TRANSFER BELT: Modular plastic belt with an integral transfer edge for smooth, self-clearing, right angle transfers onto takeaway belts.

OPEN AREA: The percentage of area in the plane of the plastic belt that is unobstructed by plastic.

OPEN GRID STYLE: Modular plastic belt with low profile, transverse ribs.

OPEN HINGE STYLE: Modular plastic belt with exposed hinge rods and a flush surface.

OUTSIDE DIAMETER: The distance from the top of a sprocket tooth to the top of the opposite tooth, measured through the centerline of the sprocket.

P

PARALLEL CARRYWAYS: Belt support rails that may be either metal or plastic, placed on the conveyor frame parallel to the belt's travel.

PERFORATED FLAT TOP STYLE: Modular plastic belt with a smooth, perforated top.

PITCH: (see *Belt Pitch* or *Module Pitch*).

PITCH DIAMETER: Diameter of a circle, which passes through the centerlines of hinge rods, when the belt is wrapped around a sprocket.

POLYACETAL: (see *Acetal*).

POLYETHYLENE: A lightweight thermoplastic, buoyant in water, with a specific gravity of 0.95. It is characterized by superior fatigue resistance, flexibility and high-impact strength. Exhibits excellent performance at low temperatures, -100 °F (-73 °C). Upper continuous temperature limit is +150 °F (+66 °C).

POLYPROPYLENE: A thermoplastic material that provides good chemical resistance characteristics. Polypropylene is buoyant in water, with a specific gravity of approximately 0.90. It is suitable for continuous service in temperatures from +34 °F (+1 °C) to +220 °F (+104 °C).

PULL-PULL BI-DIRECTIONAL CONVEYORS: There are three common variations of the Pull-pull type of reversing (bi-directional) conveyors: the center-Drive method, the Two-Motor drive method, and the Single-Motor/Slave-Drive method.

PUSHER BAR: A device used on bi-directional accumulation tables (*i.e., in the bottling and canning industries*) which allows the table to be filled to its capacity and assists in an orderly and complete discharge from the table back onto the conveying line.

PUSH-PULL BI-DIRECTIONAL CONVEYORS:

A conveyor employing one motor that will be reversing (bi-directional). In one direction the belt is being pulled and in the reversing direction the belt is being pushed.

R

RAISED RIB STYLE: Modular plastic belt with a high profile, longitudinally ribbed surface.

RETAINER RINGS: A shaft and sprocket accessory which restricts the lateral movement of the sprocket with respect to the shaft.

RETURNWAYS: The path the belt follows toward the idler shaft and sprockets.

RODS: (see *Hinge Rods*).

ROLLER CARRYWAYS: Carryway surface that does not provide a continuous running surface. The chordal action, as the modules pass over the rollers, may cause problems if product tippage is critical.

S

SCREW TAKE-UP: These types of take-ups shift the position of one of the shafts, usually the idler, through the use of adjustable machine screws.

SCROLL: Device used in place of the idle shaft and sprockets to prevent debris from accumulating on the inside of the conveyor belt. Scrolls are fabricated by welding steel left hand pitch and right hand pitch helical ribs to a common round shaft.

SERVICE FACTORS: Driven machines and power sources may be classified by severity factors, which reflect the type of service placed upon the power transmission components. High service factors are assigned to more severe applications, thereby providing sufficient component strength to render an acceptable life expectancy for that component. Additional service factors may be required for continuous service applications requiring braking (*e.g., starts/stops*) or reversing action (*e.g., bidirectional accumulation tables*). Service factors help to ensure optimal service life of the components.

SIDEGUARDS: Intralox belt accessory which forms a vertical wall near the belt edge and is an integral part of the belt.

SINGLE-MOTOR/SLAVE-DRIVE: Employing one motor (reversible) using a roller chain, alternately driving either of two chain sprockets on the conveyor shaft. This drive system is usually limited to short conveyors because of the length of roller chain involved.

SOFT START MOTORS: When rapid starts and stops of high speed and loaded conveyors occur, these devices are recommended. They allow the driven conveyor to accelerate gradually to operating speeds, which is beneficial for all conveyor components.

SPECIFIC GRAVITY: A dimensionless ratio of the density of a substance to the density of water.

STATIC ELECTRICITY: An electrical charge build-up on a surface as a result of rolling or sliding contact with another surface.

T

TAKE-UP UNITS: (see *Gravity or Screw Take-Up*).

THERMAL EXPANSION/CONTRACTION: With few exceptions, the dimensions of all substances increase as their temperature is increased and contract as their temperature is decreased. Plastics expand and contract rather significantly.

TORQUE: The capability or tendency of a force for producing torsion or rotation about an axis. For example, the twisting action on a turning shaft.

TWO-MOTOR DRIVE DESIGN: In this design, the belt is alternately pulled in either direction (*e.g., bi-directional accumulation tables*). Returnway belt tension is relatively low, requires rather expensive additional hardware (*e.g., an additional motor*), slip clutches and electrical control components.

U

U.H.M.W.: Ultra High Molecular Weight, polyethylene resin used in the manufacture of wear-strip. It has very good wear characteristics, impact resistance and has an excellent combination of physical and mechanical.

U.S.D.A.-F.S.I.S.: United States Department of Agriculture. Federal agency which regulates equipment that may be employed in Meat, Dairy and Poultry facilities.

W

WEARSTRIP: Plastic strips that are added to a conveyor frame to increase the useful life of the frame and the conveyor belting. Also helpful in reducing sliding friction forces.

A

- Abrasion Resistance System 420
- Abrasion Resistant (AR) Nylon 9
- Abrasion Resistant Nylon 15
- Accumulation Tables 471
- Acetal 9, 15, 471
 - Detectable 9
 - Electrically Conductive (EC) 10
 - X-Ray Detectable 11
- Adjusted Belt Pull 471
- Allowable Belt Strength 20, 471
- Ambient Conditions 428
- Analysis for radius and spiral belts 6
- Analysis for straight running belts 6
- Angle and clip-on wearstrips 427
- Anti-Sag Carryway Wearstrip Configuration 428

B

- Back Tension 429
- Basic Conveyor Frame Requirements 423
- Bearing Journals (see Shaft) 409
- Belt
 - Carryways 427
 - Construction 4
 - Selection 20
 - Weight 417
- Belt Carryways 427
- Belt Material Compliance 14
- Belt Material Properties 12
- Belt Pitch 471
- Belt Pull 471
- Belt Selection Instructions 20
- Belt Selection Process 5
- Belt Surface Wear 6
- Bi-Directional Conveyors 432
- Bricklaid 471

C

- Carryway (see Wearstrip)
 - Anti-Sag Carryway Wearstrip Configurations 428
 - Solid Plate 427
 - Wearstrip 416, 417, 427, 428
- Catenary 435
- Catenary Sag 429, 471
- Center-driven Belts 471
- Chemical Resistance 428
- Chevron Array 427
- Chevron Carryways 471
- Chordal Action 6, 471
- Coefficient of Friction 471
- 90° Container Transfers 441
- Control of Belt Length 428
- Conveyor design issues for friction modules 438
- Conveyors, Special 15
 - Bi-directional 432
 - Pull-Pull, Center-Drive 432

- Pull-Pull, Single-Motor and Slave-Drive 432
- Pull-Pull, Two-Motor Drive 432
- Elevating 434
- CRFR 9
- Custom Wearstrips 416

D

- Dead Plate Gap 471
- Dead Plates 417, 418, 441
- Deflection 471
- Design Requirements 5
- Detectable Acetal 9
- Detectable Nylon 9
- Detectable Polypropylene 10
- Detectable Polypropylene A22 10
- Dimension Definitions 424
- Drive Guidelines 425
- Drive Method 4, 5
- Drive Shaft (see Shaft)
 - Span 21
 - Torque Loading 425
- Dynamic Effects Of High Speed Operation 6

E

- Easy Release Plus 10
- Easy Release Traceable Polypropylene 10
- Electrically Conductive (EC) Acetal 10
- Elevating Conveyors 471
- Elongation (strain) under load 428
- Elongation due to break-in and wear 429
- End-off/End-on Transfers 440
- Enduralox Polypropylene 10
- Expansion Due to Water Absorption 420, 443
- Extended Pins 342
- Extended Tabs 342
- Extra-wide Sprockets 471
- EZ Clean In Place System 418
- EZ Clean Sprocket 416
- EZ Mount Flex Tip Scraper Data 421

F

- FDA 471
- Finger Transfer Plates 440, 471
- Flame Retardant Thermoplastic Polyester (FR-TPES) 10
- Flat Finger-Joint Wearstrips 414, 427
- Flat Plate Carryways 471
- Flat Top Style 471
- Flat Wearstrips 414
- Flight Material 413
- Flights 471
- Fluid Couplings 471
- Flush Grid Style 471
- Friction 471
- Friction Factors 12, 13
- Friction Modules 438

G

General Application Sprocket Material	15
Glass Filled Nylon	15
Glass Filled Nylon with Polypropylene Joining Plate	15
Gravity Take-Up	471
Gravity Take-up	431

H

HDPE	472
Heat Resistant (HR) Nylon	10
High Heat Resistant (HHR) Nylon	11
Hi-Impact	11
Hinge Rods	472
Hinge-Driven Belts	472
Horsepower	472

I

Idler Rollers	472
Inertia	472
Intermediate Bearings	426, 472

J

Journal Bearing, Split	419
------------------------	-----

K

Keyway	409
Knuckle Chain	472

L

Load-Bearing Rollers	472
----------------------	-----

M

Material	
Easy Release Plus	10
Easy Release Traceable Polypropylene	10
Hi-Impact	11
Self Extinguishing Low Moisture (SELM)	11
UVFR	11
Materials	
CRFR	9
Detectable Acetal	9
Detectable Nylon	9
Detectable Polypropylene	10
Detectable Polypropylene A22	10
Electrically Conductive (EC)	10
Enduralox Polypropylene	10
Flame Retardant Thermoplastic Polyester (FR-TPES)	10
Nylon	11
Abrasion Resistant	15
Abrasion Resistant (HR)	9
Heat Resistant (HR)	10
High Heat Resistant (HHR)	11
Polyethylene	9

Polypropylene	9, 15
Polypropylene Composite	11
Polysulfone	410
PVDF	11
Stainless Steel	16
UHMW	416
UV Resistant	11
X-Ray Detectable Acetal	11
Modular Construction	472
Module Pitch	472
Modules	472
Molybdenum-filled Nylon (Nylatron)	472
Moment of Inertia	21, 472

N

Nylatron	472
Nylon	11
Abrasion Resistant	15
Abrasion Resistant (AR)	9
Detectable	9
Heat Resistant (HR)	10
High Heat Resistant (HHR)	11

O

Onepiece™ Live Transfer	472
Open Area	472
Open Grid	472
Open Hinge	472
Outside Diameter	472

P

Parabolic Guide Rails	441
Parallel Carryways	472
Perforated Flat Top Style	472
Pitch	5, 472
Pitch Diameter	473
Polyacetal	473
Polyethylene	9, 15, 473
Polypropylene	9, 15, 473
Detectable	10
Detectable A22	10
Polypropylene Composite	11, 15
Polysulfone	410
Polyurethane	15
Polyurethane Composite	16
Polyurethane Composite Split	15
Power Requirements	425
Product Line	9
Product Transfer	
90° Container Transfers	441
Onepiece™ Live Transfer	442
Pull-Pull Bi-directional Conveyors	432, 473
Pusher Bar	473
Pusher Bars	417
Push-Pull Bi-directional Conveyors	473
Push-pull Bi-directional Conveyors	432
PVDF	11

R

- Radius Conveyors 438
- Raised Rib Style 473
- Requirements
 - Basic Conveyor Frame 423
- Retainer Rings 410, 411, 473
 - Round Shaft 411
 - Self-Set 411
 - Steel 417
- Retaining Sprockets 426
- Returnway
 - Required Tension 429
- Returnways 473
- Returnways and Take-Ups 428
- Rods 473
- Roller Carryways 473
- Roller returnways 430
- Rollers
 - Hold Down 416, 437
- Rollers as Idle Shafts and Sprocket Replacements 426

S

- Screw Take-up 432, 473
- Scroll 473
- Self Extinguishing Low Moisture (SELM) 11
- Series 100 23
- Series 200 29
- Series 400 37
- Series 550 63
- Series 800 67
- Series 850 97
- Series 888 105
- Series 900 113
- Series 1000 141
- Series 1100 157
- Series 1200 175
- Series 1400 189
- Series 1500 213
- Series 1600 219
- Series 1650 231
- Series 1700 235
- Series 1750 243
- Series 1800 247
- Series 1900 253
- Series 2100 289
- Series 2200 293
- Series 2300 305
- Series 2400 311
- Series 2600 361
- Series 2700 373
- Series 2800 383
- Series 2850 393
- Series 2900 397
- Series 2950 405
- Series 3000 339
- Series 4000 345
- Series 4400 259

- Series 4500 263
- Series 9000 273
- Series 10000 279
- Service Factor 20, 473
- Shaft
 - Dimensions and Tolerances 409
 - Maximum Allowable Torque 7
 - Sizes and Materials 425
 - Tolerances 409
- Shaft Strength 7
- Sideguards 473
- Single-motor/slave-drive 473
- Slider bed returnways 430
- “Slip-Stick” Effect 443
- Soft Start Motors 473
- Soft Starting Motors and Fluid Couplings 426
- Solid Plate Carryways 427
- Special Application Belt Materials 9
- Special Application Materials 16
- Special Application Sprocket Material 15
- Specific Added Belt Pull 442
- Specific Gravity 12, 473
- Split Sprockets 419
- Sprocket 419
 - EZ Clean 416
 - Float 4
 - Retaining 426
- Sprocket Material Availability 16
- Square Shaft (see also Shaft) 409
- Stainless Steel 16
- Stainless Steel Backed UHMW Wearstrip 415
- Stainless Steel Retaining Rings 410
- Standard Belt Materials 9
- Standard Flat Wearstrips 414, 427
- Standard Retainer Rings 410
- Standard Returnways 429
- Static Electricity 7, 473
- Steel, Stainless 16
- Straight, parallel runners 427
- Surface Finishes 409

T

- Take-Up
 - Gravity Style 431
 - Screw Style 432
- Take-Up Units 473
- Temperature 12
 - Effects 441
 - Factor 12
 - Limits 428
 - Variations 428
- Thermal Expansion and Contraction 428, 443, 473
- Thermoplastic 10
- Tolerances 409
- Torque 21, 473
- Transfer Design Guidelines 440
- Two-Motor Drive Design 473

U

UFVR	11
UHMW	474
UHMW Pressure Sensitive Tape	415
Ultra Abrasion Resistant Polyurethane	16
USDA-FSIS	474
UV Resistant	11

V

Vacuum Transfer Applications	442
------------------------------------	-----

W

Wearstrips	7, 414, 474
------------------	-------------

Angle	427
Carryways	427
Chevron Array	427
Clip-On	427
Design Considerations	428
Flat Finger-Joint	414, 427
Installation	428
Parallel Runners	427
Snap-On	427
Standard Flat	427
Types and Sizes	427

X

X-Ray Detectable Acetal	11
-------------------------------	----

Contact

Intralox, L.L.C. USA, New Orleans, LA, +504-733-0463, Toll Free: 1-800-535-8848

Intralox, L.L.C. Europe, Amsterdam, The Netherlands, +31-(0)20-540 36 00, Toll Free: +800-4687-2569

Intralox Shanghai LTD., Shanghai, China, Toll Free: 400-842-3469

Global Assembly Center Locations: Japan • United Kingdom • Australia • Brazil • India

Country- and industry-specific toll-free phone numbers, and information on Intralox's global locations, available at www.intralox.com.